

CE/EMC COMPLIANCE REPORT

For

PCICASE UK LTD

Switching Power Supply

Prepared for : PCICASE UK LTD
Address : Unit 14 Avant Business centre, Third Avenue Milton
Keynes, MK1 1DR United Kingdom

Prepared by : EST Technology Co., Ltd.
Address : Chilingxiang, Qishantou, Santun, Houjie, Dongguan,
Guangdong, China

Tel: 86-769-83081888

Fax: 86-769-83081878

Report No. : ESTE-E1704057-7

Date of Report : Sep. 30, 2019



TABLE OF CONTENTS

	Page
Test Report Declaration	
1. GENERAL PRODUCT INFORMATION	4
1.1. Product Function	4
1.2. Description of Device (EUT)	4
1.3. Difference between Model Numbers	4
1.4. Independent Operation Modes	4
2. TEST STANDARDS AND SITES	5
2.1. Description of Standards and Results	5
2.2. Test Facilities	6
2.3. List of Test and Measurement Instruments	7
3. TEST SET-UP AND OPERATION MODES	9
3.1. Principle of Configuration Selection	9
3.2. Block Diagram of Test Set-up	9
3.3. Test Operation Mode and Test Software	9
3.4. Special Accessories and Auxiliary Equipment	9
3.5. Countermeasures to Achieve EMC Compliance	9
4. EMISSION TEST RESULTS	10
4.1. Conducted Emission at The Mains Terminals Test	10
4.2. Radiated Emission Test	15
4.3. Harmonic Current Emissions on AC Mains Test	20
4.4. Voltage Fluctuations and Flicker on AC Mains Test	24
5. IMMUNITY TEST RESULT	26
5.1. Description of Performance Criteria	26
5.2. Electrostatic Discharge Immunity Test	27
5.3. Radio Frequency Electromagnetic Field Immunity Test	29
5.4. Electrical Fast Transient/Burst Immunity Test	31
5.5. Surge Immunity Test	33
5.6. Injected Currents Susceptibility Test	35
5.7. Power Frequency Magnetic Field Immunity Test	37
5.8. Voltage Dips and Short Interruptions Immunity Test	38
6. PHOTOGRAPHS OF TEST SET-UP	40
6.1. Set-up for Conducted Emission at the Mains Terminals Test	40
6.2. Set-up for Radiated Emission Test	41
6.3. Set-up for Harmonic Current Emissions and Flicker on AC Mains Test	41
6.4. Set-up for Electrostatic Discharge Immunity Test	42
6.5. Set-up for Radio Frequency Electromagnetic Field Immunity Test	42
6.6. Set-up for Electrical Fast Transient/Burst Immunity Test	43
6.7. Set-up for Surge Immunity Test	43
6.8. Set-up for Injected Currents Susceptibility Test	44
6.9. Set-up for Power Frequency Magnetic Field Immunity Test	44
6.10. Set-up for Voltage Dips and Short Interruptions Immunity Test	45
7. PHOTOGRAPHS OF THE EUT	46

EST Technology Co., Ltd.

Applicant:	PCICASE UK LTD		
Address:	Unit 14 Avant Business centre, Third Avenue Milton Keynes, MK1 1DR United Kingdom		
Manufacturer:	PCICASE UK LTD		
Address:	Unit 14 Avant Business centre, Third Avenue Milton Keynes, MK1 1DR United Kingdom		
E.U.T:	Switching Power Supply		
Model Number:	CRS-C2050-85-08		
Trade Name:		Serial No.:	-----
Date of Receipt:	Sep. 16, 2019	Date of Test:	Sep. 25-28, 2019
Test Specification:	EN 55032:2015 EN 61000-3-2:2019 EN 61000-3-3:2013 EN 55024:2010+A1:2015		
Test Result:	The equipment under test was found to be compliance with the requirements of the standards applied.		
		Issue Date: Sep. 30, 2019	
Prepared by:	Reviewed by:	Approved by:	
			
Lena / Assistant	Sean / Engineer	Iceman Hu / Manager	
Other Aspects:	None.		
<i>Abbreviations: OK/P=passed fail/F=failed n.a/N=not applicable E.U.T=equipment under tested</i>			
<i>This test report is based on a single evaluation of one sample of above mentioned products. It is not permitted to be duplicated in extracts without written approval of EST Technology Co., Ltd.</i>			

1. GENERAL PRODUCT INFORMATION

1.1. Product Function

Refer to Technical Construction Form and User Manual.

1.2. Description of Device (EUT)

Description	: Switching Power Supply
Model No.	: CRS-C2050-85-08
System Input Voltage	: AC 115V-230V 47/63Hz 7.0A max
Output	: DC +5V 17.0A, DC +3.3V 18.0A, DC +12V 38.0A, DC -12.0V 0.3A, DC +5Vsb 2.5A, DC +5V & 3.3V
Power	: 500W Max
AC Line	: Unshielded, Detachable 1.6 m

1.3. Difference between Model Numbers

None.

1.4. Independent Operation Modes

The basic operation modes are:

1.4.1. Full Load

2. TEST STANDARDS AND SITES

2.1. Description of Standards and Results

The EUT have been tested according to the applicable standards as referenced below.

EMISSION(EN 55032:2015)				
Description of Test Item	Standard	Limits		Results
Conducted disturbance at mains terminals	EN 55032:2015	Class B		PASS
		Minimum passing margin is 3.43dB at 0.190MHz		
Asymmetric mode conducted emissions	EN 55032:2015	Class B		N/A
		More than *** dB below the limit line.		
Radiated disturbance	EN 55032:2015	Class B		PASS
		Minimum passing margin is 6.59dB at 140.580MHz		
Harmonic current emissions	EN 61000-3-2:2019	Class D		PASS
Voltage fluctuations & flicker	EN 61000-3-3:2013	Section 4.4		PASS
IMMUNITY (EN 55024:2010+A1:2015)				
Description of Test Item	Basic Standard	Performance Criteria	Observation Criteria	Results
Electrostatic discharge (ESD)	EN 61000-4-2:2009	B	B	PASS
Radio-frequency, Continuous radiated disturbance	EN 61000-4-3:2006+A1:2008+A2:2010	A	A	PASS
Electrical fast transient (EFT)	EN 61000-4-4:2012	B	B	PASS
Surge (Input a.c. power port)	EN 61000-4-5:2014	B	B	PASS
Radio-frequency, Continuous conducted disturbance	EN 61000-4-6:2014	A	A	PASS
Power frequency magnetic field	EN 61000-4-8:2010	A	A	PASS
Voltage dips, >95% reduction	EN 61000-4-11:2004	B	B	PASS
Voltage dips, 30% reduction		C	C	PASS
Voltage interruptions		C	C	PASS
N/A is an abbreviation for Not Applicable.				

2.2. Test Facilities

- EMC Lab : Certificated by CNAS, CHINA
Registration No.: L5288
Date of registration: November 13, 2017
- Certificated by FCC, USA
Designation Number: CN1215
Test Firm Registration Number: 722932
Date of registration: November 21, 2017
- Certificated by A2LA, USA
Registration No.: 4366.01
Date of registration: November 07, 2017
- Certificated by Industry Canada
CAB identifier No.: CN0035
Date of registration: January 04, 2019
- Certificated by VCCI, Japan
Registration No.: R-13663; C-14103
Date of registration: July 25, 2017
This Certificate is valid until: July 24, 2020
- Certificated by TUV Rheinland, Germany
Registration No.: UA 50413872 0001
Date of registration: July 31, 2018
- Certificated by TUV/PS, Shenzhen
Registration No.: SCN1017
Date of registration: January 27, 2011
- Certificated by Intertek
Registration No.: 2011-RTL-L2-64
Date of registration: November 08, 2018
- Name of Firm : EST Technology Co., Ltd.
- Site Location : Chilingxiang, Qishantou, Santun, Houjie, Dongguan,
Guangdong, China

2.3.List of Test and Measurement Instruments

2.3.1. For conducted emission at the mains terminals test (2# conduction)

Equipment	Manufacturer	Model No.	Serial No.	Last Cal.	Next Cal.
EMI Test Receiver	Rohde & Schwarz	ESPR3	EST-E070	June 14,19	1 Year
Artificial Mains Network	Rohde & Schwarz	ENV216	EST-E048	June 14,19	1 Year
Test Software	Audix	e3-6.111221a	N/A	N/A	N/A

2.3.2. For radiated emission test (1# 966 radiation)

Equipment	Manufacturer	Model No.	Serial No.	Last Cal.	Next Cal.
EMI Test Receiver	Rohde & Schwarz	ESR7	EST-E047	June 14,19	1 Year
Bilog Antenna	Teseq	CBL 6111D	EST-E034	June 14,19	1 Year
Test Software	Audix	e3-6.111221a	N/A	N/A	N/A

2.3.3. For harmonic current emissions and voltage fluctuations/flicker test

Equipment	Manufacturer	Model No.	Serial No.	Last Cal.	Next Cal.
Power Analyzer	California Instruments	3001IX-208-CTS	EST-E011	June 14,19	1 Year
Voltage Source	California Instruments	3001IX-208	EST-E012	June 14,19	1 Year
Test Software	California Instruments	CTS	N/A	N/A	N/A

2.3.4. For electrostatic discharge immunity test

Equipment	Manufacturer	Model No.	Serial No.	Last Cal.	Next Cal.
ESD Generator	HAEFELY	ONYX16	EST-E013	June 14,19	1 Year

2.3.5. Radio Frequency Electromagnetic Field Immunity (R/S) Test

Equipment	Manufacturer	Model No.	Serial No.	Last Cal.	Next Cal.
Signal Generator	Agilent	N5181A	EST-E060	Nov. 30, 18	1 Year
Power Amplifier	SKET	HAP801000M-2 50W	EST-E061	N/A	N/A
Power Amplifier	SKET	HAP0103G-75W	EST-E062	N/A	N/A
Power Amplifier	SKET	HAP0306G-50W	EST-E063	N/A	N/A
Power Meter	Agilent	E4419B	EST-E064	June 14,19	1 Year
Power sensor	Agilent	E9301A	EST-E065	June 14,19	1 Year
Power sensor	HP	E9301A	EST-E066	June 14,19	1 Year
Antenna	Schwarzbeck	STLP 9129	EST-E059	N/A	N/A
E-Field Probe	Narda	EP-601	EST-E067	June 14,19	1 Year
Test Software	SKET	EMC-S	V1.2.0.48	N/A	N/A

2.3.6. For electrical fast transient/burst immunity test

Equipment	Manufacturer	Model No.	Serial No.	Last Cal.	Next Cal.
EFT Generator	EMC PARTNER	TRANSIENT 2000	EST-E074	June 14,19	1 Year
Capacitive Coupling Clamp	HAEFELY	IP4A	EST-E040	June 14,19	1 Year

2.3.7. For surge immunity test

Equipment	Manufacturer	Model No.	Serial No.	Last Cal.	Next Cal.
Surge Controller	HAEFELY	PSURGE8000	EST-E015	June 14,19	1 Year
Surge Impulse Module	HAEFELY	PIM100	EST-E016	June 14,19	1 Year
Surge Coupling Network	HAEFELY	PCD100	EST-E017	June 14,19	1 Year

2.3.8. For injected currents susceptibility test

Equipment	Manufacturer	Model No.	Serial No.	Last Cal.	Next Cal.
Signal Generator	Rohde &Schwarz	SMB100A	EST-E025	June 14,19	1 Year
Power Amplifier	FRANKONIA	CIT-10	EST-E021	June 14,19	1 Year
Power Meter	Rohde &Schwarz	NRVS	EST-E027	June 14,19	1 Year
CDN	FRANKONIA	CDN-M2+M3	EST-E022	June 14,19	1 Year
EM-Clamp	FRANKONIA	EMCL-20	EST-E042	June 14,19	1 Year
Test Software	SKET	EMC-S	V1.2.0.80	N/A	N/A

2.3.9.For power frequency magnetic field immunity test

Equipment	Manufacturer	Model No.	Serial No.	Last Cal.	Next Cal.
Magnetic Field Tester	HAEFELY	MFS 100	EST-E018	June 14,19	1 Year

2.3.10.For voltage dips and short interruptions immunity test

Equipment	Manufacturer	Model No.	Serial No.	Last Cal.	Next Cal.
DIPS Tester	EMC PARTNER	TRANSIENT 2000	EST-E074	June 14,19	1 Year

Note: All calibration reports of the equipment were provided by LiSai calibration and Testing

3. TEST SET-UP AND OPERATION MODES

3.1. Principle of Configuration Selection

Emission: The equipment under test (EUT) was configured to measure its highest possible radiation level. The test modes were adapted accordingly in reference to the Operating Instructions.

Immunity: The equipment under test (EUT) was configured to the representative operating mode and conditions.

3.2. Block Diagram of Test Set-up

System Diagram of Connections Between EUT and Simulators

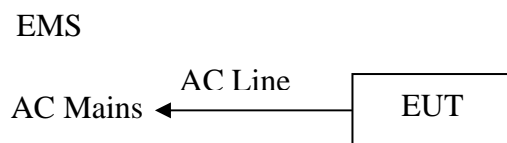
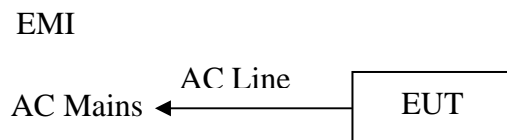

(EUT: Switching Power Supply)

3.3. Test Operation Mode and Test Software

Refer to Test Setup in clause 4 & 5.

3.4. Special Accessories and Auxiliary Equipment

None.

3.5. Countermeasures to Achieve EMC Compliance

None.

4. EMISSION TEST RESULTS

4.1. Conducted Emission at The Mains Terminals Test

RESULT : **Pass**
Test procedure : EN 55032:2015
Frequency range : 0.15~30MHz
Test Site : Shielded Room
Limits : EN 55032:2015 Class B

Test Setup

Date of test : Sep. 28, 2019
Model No. : CRS-C2050-85-08
Input Voltage : AC 110V/60Hz, AC 230V/50Hz
Operation Mode : Full Load

The frequency range from 150 kHz to 30 MHz was investigated.

The bandwidth of the test receiver was set at 9 kHz.

The test data of the worst case condition(s) was reported on the following page.

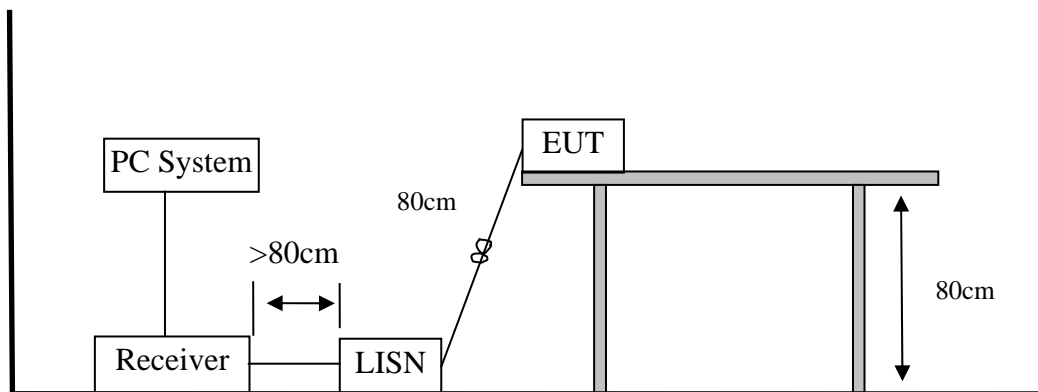

Note: Test uncertainty: $\pm 3.38\text{dB}$ at a level of confidence of 95%.

Test Data

EST Technology

Chilingxiang, Qishantou, Santun,
Houjie, Dongguan, Guangdong, China
Tel: +86-769-83081888
Fax: +86-769-83081878

Data: 406

File: \\EMC-CE-2\Test Data\2019\C\Channel Well\EM6 (412)

Date: 2019-09-28

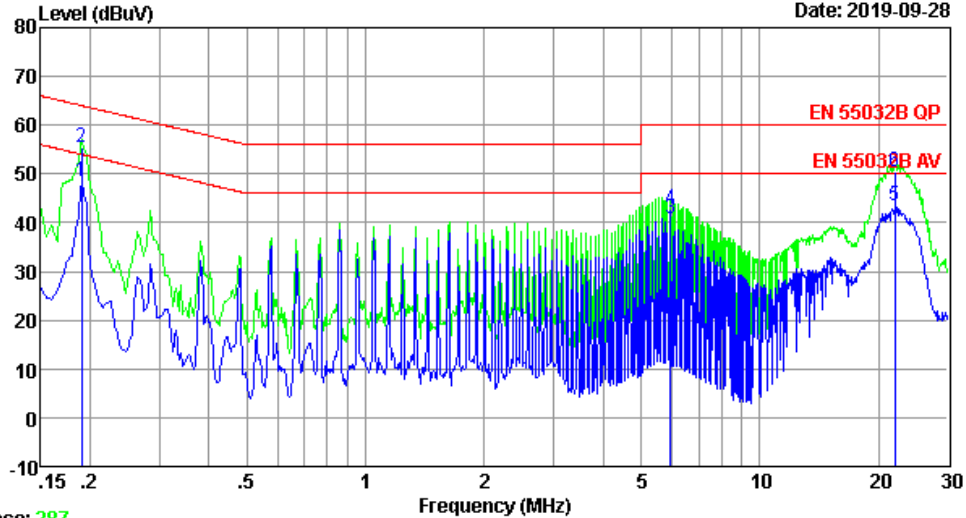

Trace: 287

Site no : 2# Conduction Shield Room Data no. : 406
 Env. / Ins. : Temp:26.5°C Humi:63% Press:101.50kPa LINE Phase : NEUTRAL
 Limit : EN 55032B QP
 Engineer : XJ
 EUT : Switching Power Supply
 Power : AC 230V/50Hz
 M/N : CRS-C2050-85-08
 Test Mode : Full Load

	Freq. (MHz)	LISN Factor (dB)	Cable Loss (dB)	Reading (dBuV)	Emission Level (dBuV)	Limits (dBuV)	Margin (dB)	Remark
1	0.190	9.65	0.04	38.88	48.57	54.02	5.45	Average
2	0.190	9.65	0.04	45.81	55.50	64.02	8.52	QP
3	5.929	9.75	0.07	31.00	40.82	50.00	9.18	Average
4	5.929	9.75	0.07	32.92	42.74	60.00	17.26	QP
5	22.063	10.00	0.09	33.24	43.33	50.00	6.67	Average
6	22.063	10.00	0.09	40.20	50.29	60.00	9.71	QP

Remarks: 1. Emission Level= LISN Factor + Cable Loss + Reading.
 2. Margin= Limit - Emission Level.
 3. If the average limit is met when using a quasi-peak detector,
 the EUT shall be deemed to meet both limits and measurement
 with average detector is unnecessary.

Data: 408 File: \\EMC-CE-2\Test Data\2019\C\Channel Well.EM6 (412)

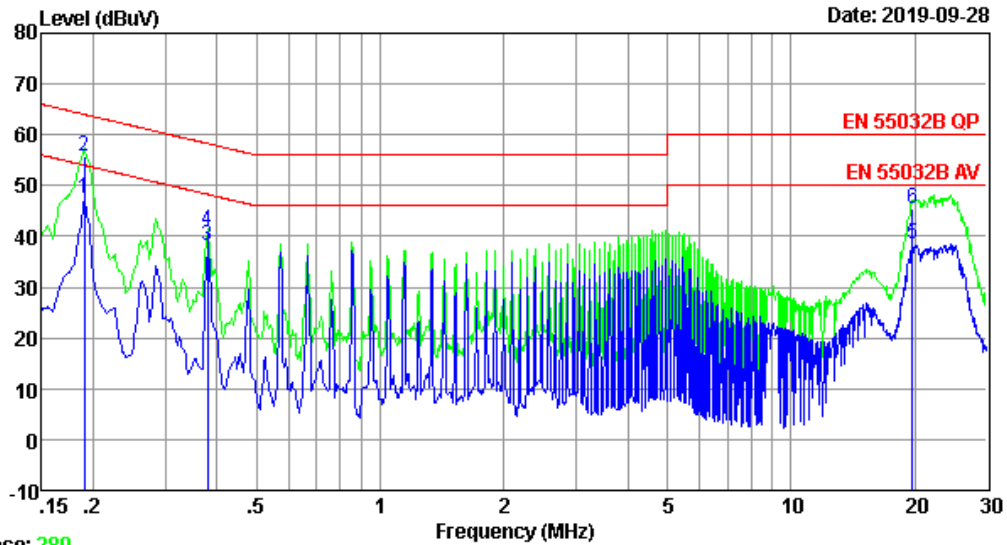

Trace: 289
 Site no : 2# Conduction Shield Room Data no. : 408
 Env. / Ins. : Temp:26.5°C Humi:63% Press:101.50kPa LINE Phase : LINE
 Limit : EN 55032B QP
 Engineer : XJ
 EUT : Switching Power Supply
 Power : AC 230V/50Hz
 M/N : CRS-C2050-85-08
 Test Mode : Full Load

	Freq. (MHz)	LISN Factor (dB)	Cable Loss (dB)	Reading (dBuV)	Emission Level (dBuv)	Limits (dBuv)	Margin (dB)	Remark
1	0.190	9.69	0.04	37.82	47.55	54.02	6.47	Average
2	0.190	9.69	0.04	45.88	55.61	64.02	8.41	QP
3	0.379	9.75	0.05	28.30	38.10	48.30	10.20	Average
4	0.379	9.75	0.05	31.38	41.18	58.30	17.12	QP
5	19.740	10.02	0.09	28.39	38.50	50.00	11.50	Average
6	19.740	10.02	0.09	35.30	45.41	60.00	14.59	QP

Remarks: 1. Emission Level= LISN Factor + Cable Loss + Reading.
 2. Margin= Limit - Emission Level.
 3. If the average limit is met when using a quasi-peak detector,
 the EUT shall be deemed to meet both limits and measurement
 with average detector is unnecessary.

Data: 410 File: \\EMC-CE-2\Test Data\2019\C\Channel Well\EM6 (412)

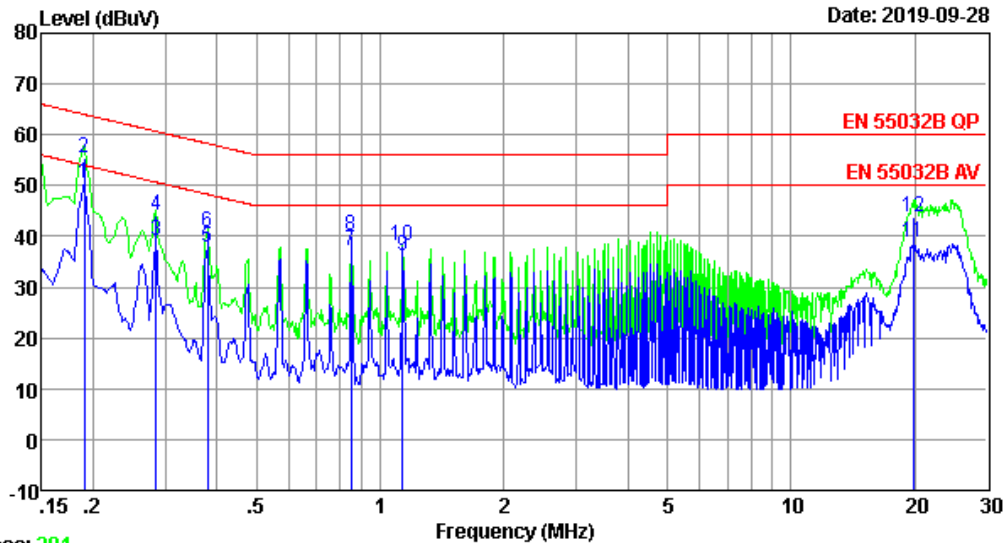

Trace: 291
 Site no : 2# Conduction Shield Room Data no. : 410
 Env. / Ins. : Temp:26.5°C Humi:63% Press:101.50kPa LINE Phase : LINE
 Limit : EN 55032B QP
 Engineer : XJ
 EUT : Switching Power Supply
 Power : AC 110V/60Hz
 M/N : CRS-C2050-85-08
 Test Mode : Full Load

	Freq. (MHz)	LISN Factor (dB)	Cable Loss (dB)	Reading (dBuV)	Emission Level (dBuv)	Limits (dBuv)	Margin (dB)	Remark
1	0.190	9.69	0.04	40.86	50.59	54.02	3.43	Average
2	0.190	9.69	0.04	45.81	55.54	64.02	8.48	QP
3	0.285	9.72	0.04	29.44	39.20	50.68	11.48	Average
4	0.285	9.72	0.04	34.48	44.24	60.68	16.44	QP
5	0.379	9.75	0.05	27.97	37.77	48.30	10.53	Average
6	0.379	9.75	0.05	30.91	40.71	58.30	17.59	QP
7	0.848	9.86	0.05	27.20	37.11	46.00	8.89	Average
8	0.848	9.86	0.05	30.12	40.03	56.00	15.97	QP
9	1.135	9.88	0.06	26.34	36.28	46.00	9.72	Average
10	1.135	9.88	0.06	28.31	38.25	56.00	17.75	QP
11	19.845	10.02	0.09	28.64	38.75	50.00	11.25	Average
12	19.845	10.02	0.09	33.60	43.71	60.00	16.29	QP

Remarks: 1. Emission Level= LISN Factor + Cable Loss + Reading.
 2. Margin= Limit - Emission Level.
 3. If the average limit is met when using a quasi-peak detector,
 the EUT shall be deemed to meet both limits and measurement
 with average detector is unnecessary.

Data: 412 File: \\EMC-CE-2\Test Data\2019\C\Channel Well\EM6 (412)

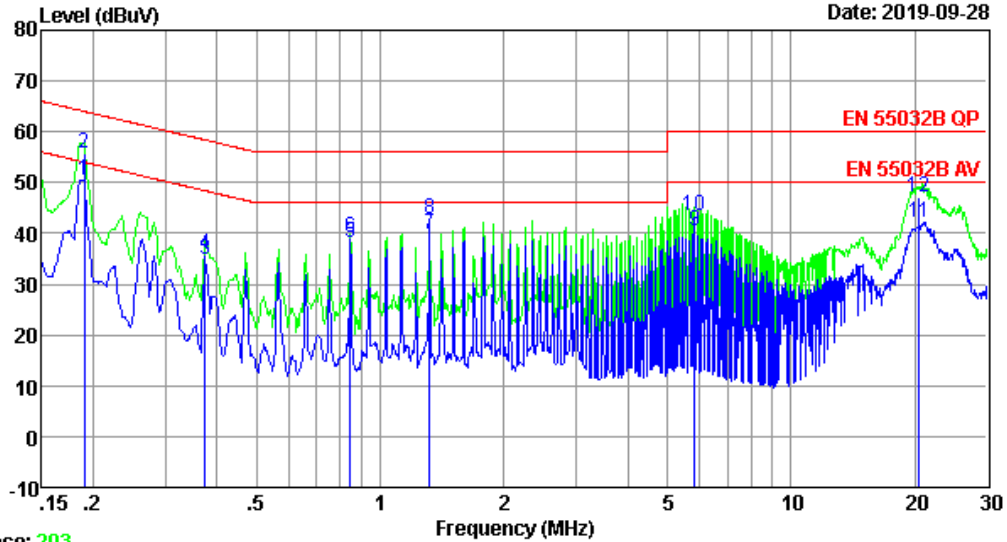

Trace: 293
 Site no : 2# Conduction Shield Room Data no. : 412
 Env. / Ins. : Temp:26.5°C Humi:63% Press:101.50kPa LINE Phase : NEUTRAL
 Limit : EN 55032B QP
 Engineer : XJ
 EUT : Switching Power Supply
 Power : AC 110V/60Hz
 M/N : CRS-C2050-85-08
 Test Mode : Full Load

	Freq. (MHz)	LISN Factor (dB)	Cable Loss (dB)	Reading (dBuV)	Emission Level (dBuV)	Limits (dBuV)	Margin (dB)	Remark
1	0.190	9.65	0.04	40.87	50.56	54.02	3.46	Average
2	0.190	9.65	0.04	46.12	55.81	64.02	8.21	QP
3	0.375	9.67	0.05	25.03	34.75	48.39	13.64	Average
4	0.375	9.67	0.05	25.99	35.71	58.39	22.68	QP
5	0.844	9.74	0.05	28.45	38.24	46.00	7.76	Average
6	0.844	9.74	0.05	29.42	39.21	56.00	16.79	QP
7	1.317	9.77	0.06	29.88	39.71	46.00	6.29	Average
8	1.317	9.77	0.06	32.91	42.74	56.00	13.26	QP
9	5.836	9.77	0.07	30.51	40.35	50.00	9.65	Average
10	5.836	9.77	0.07	33.71	43.55	60.00	16.45	QP
11	20.486	9.98	0.09	32.10	42.17	50.00	7.83	Average
12	20.486	9.98	0.09	37.11	47.18	60.00	12.82	QP

Remarks: 1. Emission Level= LISN Factor + Cable Loss + Reading.
 2. Margin= Limit - Emission Level.
 3. If the average limit is met when using a quasi-peak detector,
 the EUT shall be deemed to meet both limits and measurement
 with average detector is unnecessary.

4.2. Radiated Emission Test

RESULT : **Pass**
Test procedure : EN 55032:2015
Frequency range : 30~1000MHz
Test Site : 966 Chamber
Limits : EN 55032:2015 Class B

Test Setup

Date of test : Sep. 27, 2019
Model No. : CRS-C2050-85-08
Input Voltage : AC 110V/60Hz, AC 230V/50Hz
Operation Mode : Full Load

The EUT was placed on a turn table which was 0.8 m above the ground. The turn table can rotate 360 degrees to determine the position of the maximum emission level. The EUT was set 3 m distance from the receiving antenna which was mounted on an antenna tower. The measuring antenna moved up and down to find out the maximum emission level. It moved from 1 m to 4 m for both horizontal and vertical polarizations.

The EUT was tested in the Chamber Site. It was pre-scanned with a Peak detector from the spectrum, and all the final readings from the test receiver were measured with the Quasi-Peak detector.

The bandwidth setting on the test receiver was 120 kHz.

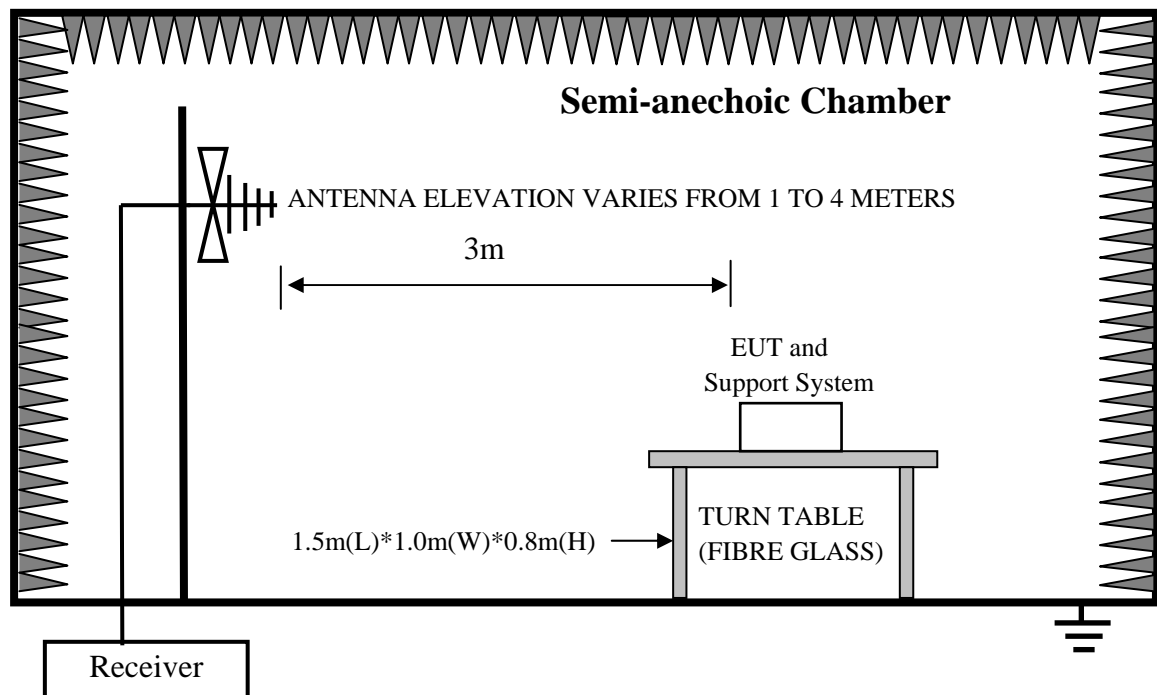

Note: Test uncertainty: ± 4.48 dB (H); ± 4.58 dB (V) at a level of confidence of 95%.

Test Data

EST Technology

Chilingxiang, Qishantou, Santun,
Houjie, Dongguan, Guangdong, China
Tel: +86-769-83081888
Fax: +86-769-83081878

Data: 86 File: \\EMC-966-1\test data\2019\EMC\C\Channel Well\EM6 (89)

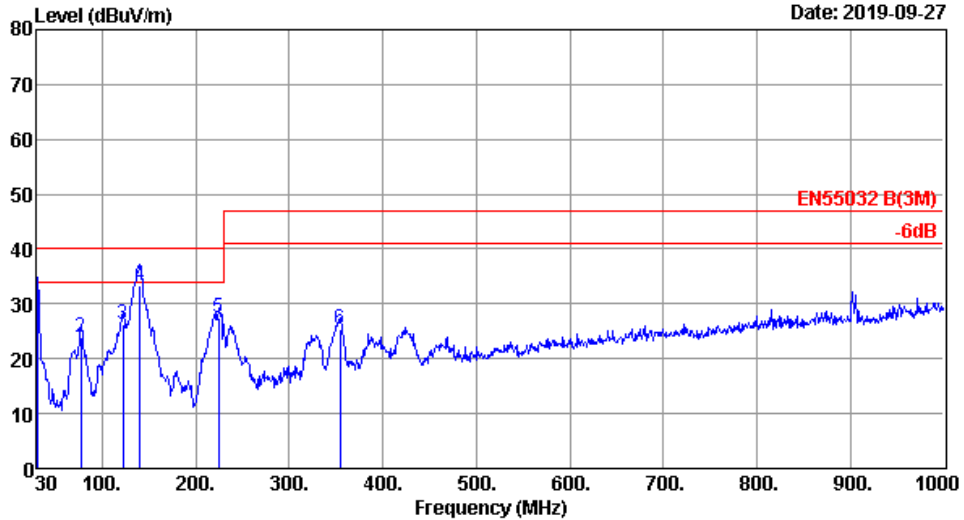

Site no. : 1# 966 Chamber Data no. : 86
 Dis. / Ant. : 3m 37062 Ant. pol. : VERTICAL
 Limit : EN55032 B(3M)
 Env. / Ins. : Temp:17';Humi:68%;Press:101.52kPa
 Engineer : ZERO
 EUT : Switching Power Supply
 Power : AC 230V/50Hz
 M/N : CRS-C2050-85-08
 Test Mode : Full Load

	Freq. (MHz)	ANT Factor (dB/m)	Cable Loss (dB)	Reading (dBuV)	Emission Level (dBuV/m)	Limit (dBuV/m)	Margin (dB)	Remark
1	30.97	17.60	0.14	13.54	31.28	40.00	8.72	QP
2	77.53	7.15	0.64	16.08	23.87	40.00	16.13	QP
3	122.15	11.38	0.94	13.96	26.28	40.00	13.72	QP
4	140.58	0.00	0.95	32.46	33.41	40.00	6.59	QP
5	224.00	10.16	1.47	15.68	27.31	40.00	12.69	QP
6	353.98	15.32	2.13	7.96	25.41	47.00	21.59	QP

Remarks: 1. Emission Level= Antenna Factor + Cable Loss + Reading.
 2. Margin= Limit - Emission Level.
 3. The emission levels that are 20dB below the official limit are not reported.



Data: 87 File: \\EMC-966-1\test data\2019\EMC\C\Channel Well.EM6 (89)

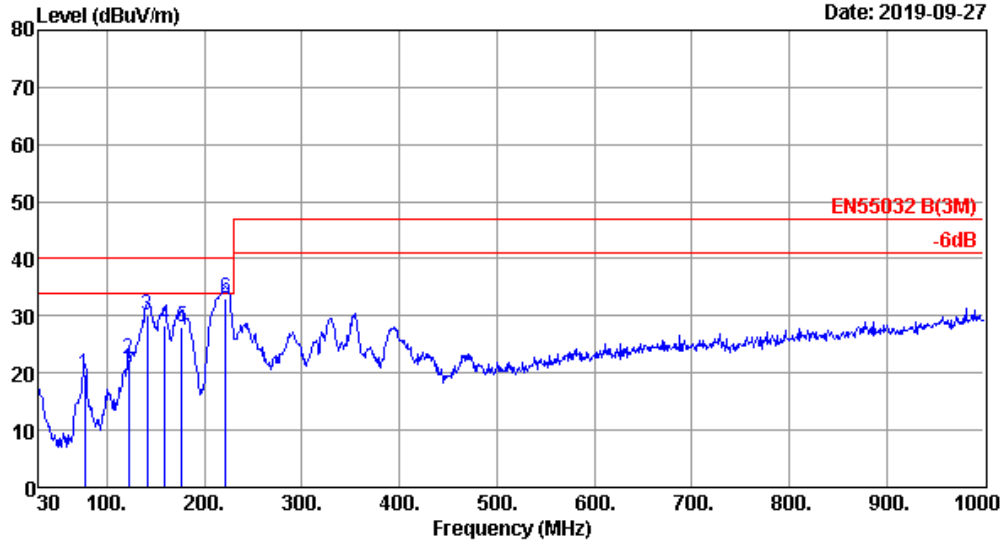

Site no. : 1# 966 Chamber Data no. : 87
 Dis. / Ant. : 3m 37062 Ant. pol. : HORIZONTAL
 Limit : EN55032 B(3M)
 Env. / Ins. : Temp:17';Humi:68%;Press:101.52kPa
 Engineer : ZERO
 EUT : Switching Power Supply
 Power : AC 230V/50Hz
 M/N : CRS-C2050-85-08
 Test Mode : Full Load

	Freq. (MHz)	ANT Factor (dB/m)	Cable Loss (dB)	Reading (dBuV)	Emission Level (dBuV/m)	Limit (dBuV/m)	Margin (dB)	Remark
1	77.53	7.15	0.64	11.85	19.64	40.00	20.36	QP
2	122.15	11.38	0.94	10.00	22.32	40.00	17.68	QP
3	141.55	12.23	1.05	16.77	30.05	40.00	9.95	QP
4	159.01	11.30	1.14	15.81	28.25	40.00	11.75	QP
5	176.47	9.70	1.20	17.23	28.13	40.00	11.87	QP
6	222.06	9.88	1.45	21.72	33.05	40.00	6.95	QP

Remarks: 1. Emission Level= Antenna Factor + Cable Loss + Reading.
 2. Margin= Limit - Emission Level.
 3. The emission levels that are 20dB below the official limit are not reported.

Data: 88 File: \\EMC-966-1\test data\2019\EMC\C\Channel Well.EM6 (89)

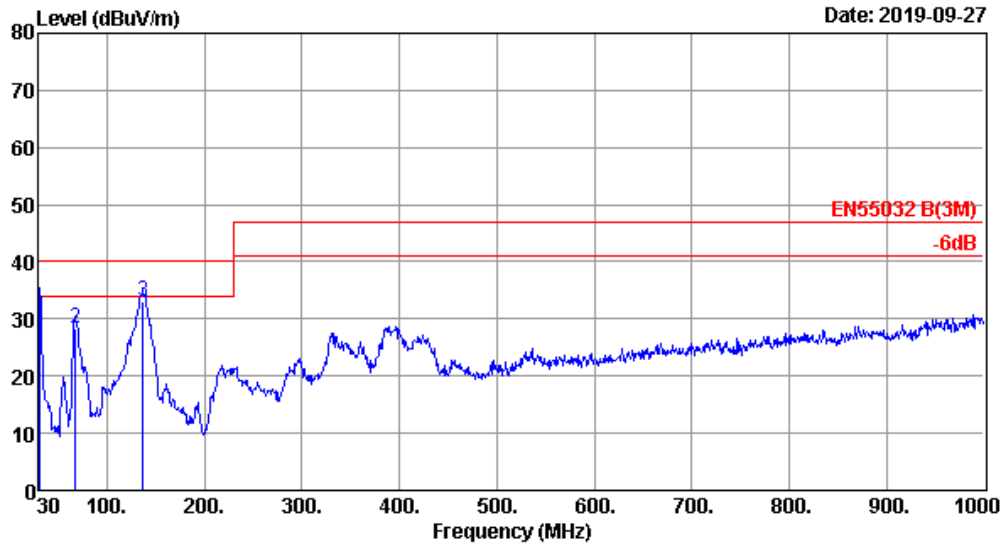

Site no. : 1# 966 Chamber Data no. : 88
 Dis. / Ant. : 3m 37062 Ant. pol. : VERTICAL
 Limit : EN55032 B(3M)
 Env. / Ins. : Temp:17';Humi:68%;Press:101.52kPa
 Engineer : ZERO
 EUT : Switching Power Supply
 Power : AC 110V/60Hz
 M/N : CRS-C2050-85-08
 Test Mode : Full Load

	Freq. (MHz)	ANT Factor (dB/m)	Cable Loss (dB)	Reading (dBuV)	Emission Level (dBuV/m)	Limit (dBuV/m)	Margin (dB)	Remark
1	30.97	17.60	0.14	13.80	31.54	40.00	8.46	QP
2	67.83	6.10	0.50	21.79	28.39	40.00	11.61	QP
3	136.70	11.96	1.01	20.15	33.12	40.00	6.88	QP

Remarks: 1. Emission Level= Antenna Factor + Cable Loss + Reading.
 2. Margin= Limit - Emission Level.
 3. The emission levels that are 20dB below the official limit are not reported.

Data: 89 File: \\EMC-966-1\test data\2019\EMC\C\Channel Well\EM6 (89) Date: 2019-09-27

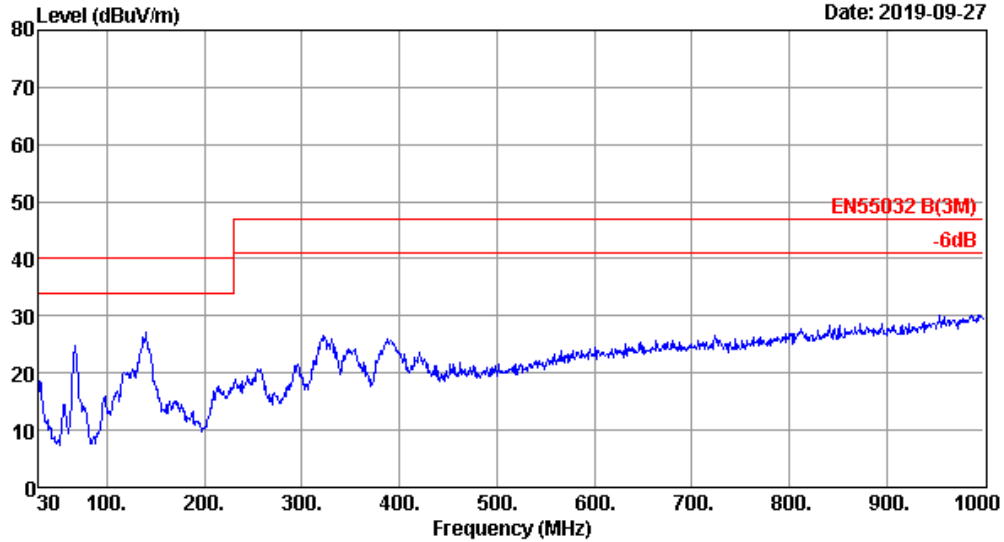

Site no. : 1# 966 Chamber Data no. : 89
 Dis. / Ant. : 3m 37062 Ant. pol. : HORIZONTAL
 Limit : EN55032 B(3M)
 Env. / Ins. : Temp:17';Humi:68%;Press:101.52kPa
 Engineer : ZERO
 EUT : Switching Power Supply
 Power : AC 110V/60Hz
 M/N : CRS-C2050-85-08
 Test Mode : Full Load

4.3. Harmonic Current Emissions on AC Mains Test

RESULT : **Pass**
Test procedure : EN 61000-3-2:2019
Measured harmonics : 1~40th
Limits : EN 61000-3-2:2019

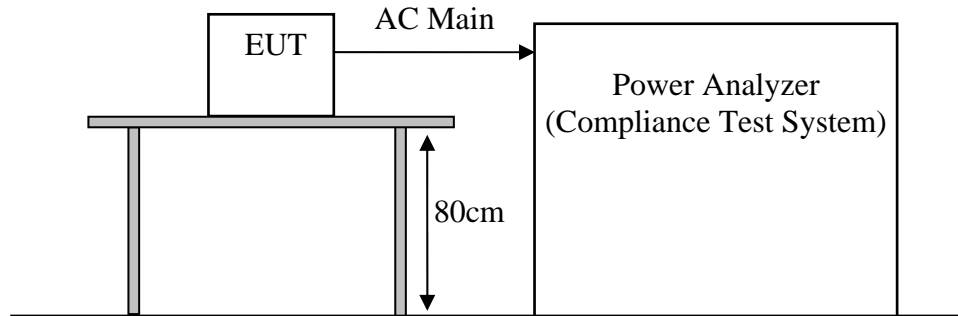

Harmonics – Class-D per Ed. Ed. 5.0 (2018)(Run time)

EUT: Switching power supply M/N:CRS-C2050-85-08 Tested by: TEA
Test category: Class-D per Ed. 5.0 (2018) (European limits) Test Margin: 100
Test date: 2019/9/28 Start time: 9:47:34 End time: 9:50:15
Test duration (min): 2.5 Data file name: H-000593.cts_data
Comment: Full Load
Customer: Channel well

Test Result: Pass Source qualification: Normal

Current & voltage waveforms

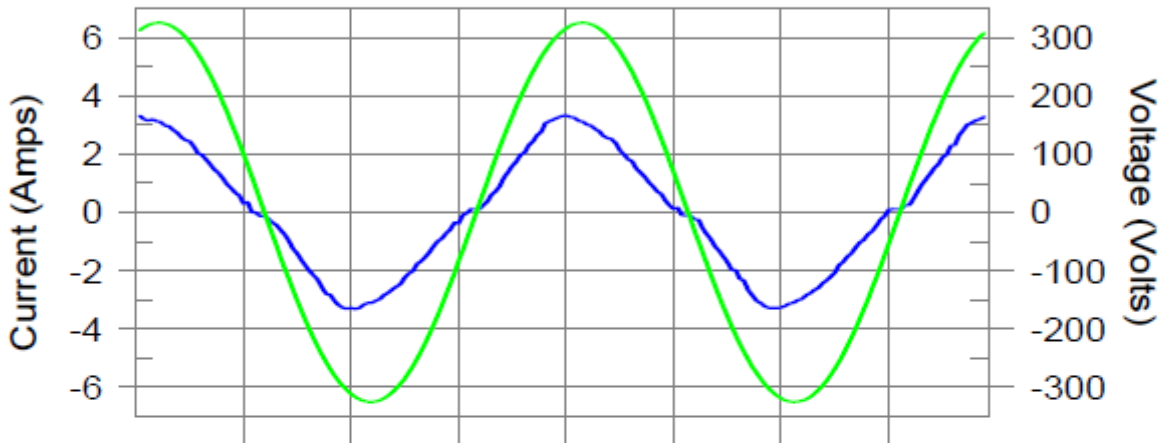

Harmonics and Class D limit line European Limits

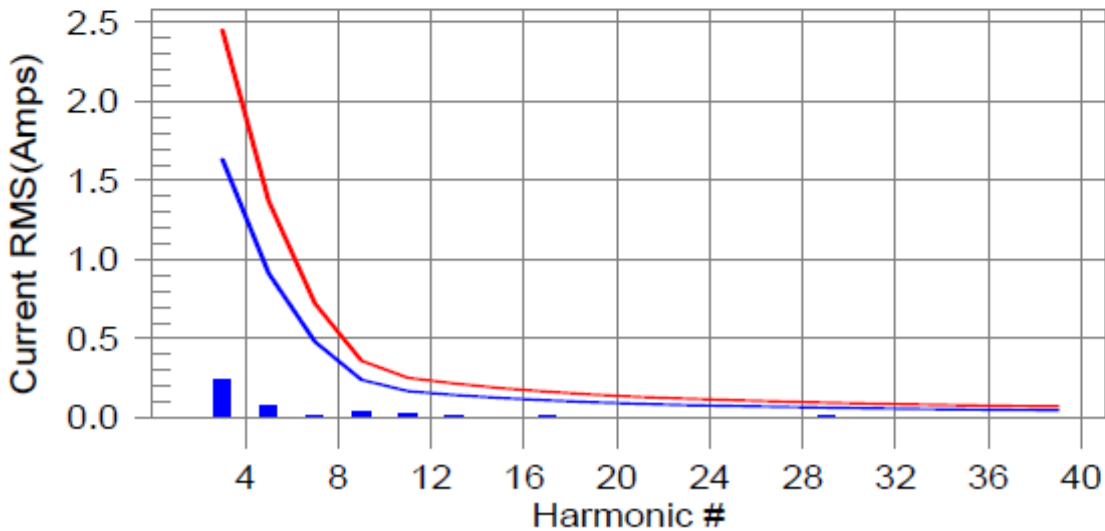

Test result: Pass Worst harmonics H9-10.5% of 150% limit, H9-15.3% of 100% limit

Current Test Result Summary (Run time)

EUT: Switching power supply M/N:CRS-C2050-85-08 **Tested by:** TEA
Test category: Class-D per Ed. 5.0 (2018) (European limits) **Test Margin:** 100
Test date: 2019/9/25 **Start time:** 9:47:34 **End time:** 9:50:15
Test duration (min): 2.5 **Data file name:** H-000593.cts_data
Comment: Full Load
Customer: Channel well

Test Result: Pass **Source qualification:** Normal
THC(A): 0.252 **I-THD(%):** 12.0 **POHC(A):** 0.012 **POHC Limit(A):** 0.207

Highest parameter values during test:

V RMS (Volts): 230.48	Frequency(Hz): 50.00
I Peak (Amps): 3.450	I RMS (Amps): 2.121
I Fund (Amps): 2.105	Crest Factor: 1.628
Power (Watts): 481.3	Power Factor: 0.986

Harm#	Harms(avg)	100%Limit	%of Limit	Harms(max)	150%Limit	%of Limit	Status
2	0.003	0.000	N/A	0.004	0.000	N/A	Pass
3	0.237	1.637	14.5	0.239	2.455	9.7	Pass
4	0.001	0.000	N/A	0.002	0.000	N/A	Pass
5	0.072	0.915	7.8	0.076	1.372	5.5	Pass
6	0.001	0.000	N/A	0.002	0.000	N/A	Pass
7	0.014	0.481	2.9	0.016	0.722	2.3	Pass
8	0.001	0.000	N/A	0.002	0.000	N/A	Pass
9	0.037	0.241	15.3	0.038	0.361	10.5	Pass
10	0.002	0.000	N/A	0.002	0.000	N/A	Pass
11	0.021	0.168	12.6	0.023	0.253	9.1	Pass
12	0.002	0.000	N/A	0.002	0.000	N/A	Pass
13	0.007	0.144	N/A	0.010	0.217	N/A	Pass
14	0.001	0.000	N/A	0.001	0.000	N/A	Pass
15	0.005	0.125	N/A	0.007	0.188	N/A	Pass
16	0.001	0.000	N/A	0.001	0.000	N/A	Pass
17	0.010	0.111	N/A	0.013	0.166	N/A	Pass
18	0.001	0.000	N/A	0.001	0.000	N/A	Pass
19	0.005	0.098	N/A	0.006	0.147	N/A	Pass
20	0.001	0.000	N/A	0.002	0.000	N/A	Pass
21	0.002	0.088	N/A	0.003	0.132	N/A	Pass
22	0.001	0.000	N/A	0.003	0.000	N/A	Pass
23	0.005	0.080	N/A	0.007	0.121	N/A	Pass
24	0.002	0.000	N/A	0.007	0.000	N/A	Pass
25	0.002	0.074	N/A	0.005	0.111	N/A	Pass
26	0.002	0.000	N/A	0.006	0.000	N/A	Pass
27	0.006	0.069	N/A	0.007	0.103	N/A	Pass
28	0.002	0.000	N/A	0.004	0.000	N/A	Pass
29	0.006	0.064	N/A	0.008	0.096	N/A	Pass
30	0.001	0.000	N/A	0.002	0.000	N/A	Pass
31	0.003	0.060	N/A	0.005	0.090	N/A	Pass
32	0.002	0.000	N/A	0.003	0.000	N/A	Pass
33	0.002	0.056	N/A	0.004	0.084	N/A	Pass
34	0.001	0.000	N/A	0.002	0.000	N/A	Pass
35	0.004	0.053	N/A	0.005	0.079	N/A	Pass
36	0.001	0.000	N/A	0.002	0.000	N/A	Pass
37	0.003	0.050	N/A	0.005	0.075	N/A	Pass
38	0.001	0.000	N/A	0.001	0.000	N/A	Pass
39	0.004	0.048	N/A	0.005	0.071	N/A	Pass
40	0.001	0.000	N/A	0.002	0.000	N/A	Pass



Voltage Source Verification Data (Run time)

EUT: Switching power supply M/N:CRS-C2050-85-08 Tested by: TEA
 Test category: Class-D per Ed. 5.0 (2018) (European limits) Test Margin: 100
 Test date: 2019/9/25 Start time: 9:47:34 End time: 9:50:15
 Test duration (min): 2.5 Data file name: H-000593.cts_data
 Comment: Full Load
 Customer: Channel well

Test Result: Pass Source qualification: Normal

Highest parameter values during test:

Voltage (Vrms): 230.48	Frequency(Hz): 50.00
I Peak (Amps): 3.450	I RMS (Amps): 2.121
I Fund (Amps): 2.105	Crest Factor: 1.628
Power (Watts): 481.3	Power Factor: 0.986

Harm#	Harmonics V-rms	Limit V-rms	% of Limit	Status
2	0.058	0.461	12.57	OK
3	0.431	2.074	20.79	OK
4	0.039	0.461	8.55	OK
5	0.037	0.922	4.04	OK
6	0.023	0.461	5.09	OK
7	0.016	0.691	2.26	OK
8	0.028	0.461	6.03	OK
9	0.029	0.461	6.21	OK
10	0.021	0.461	4.48	OK
11	0.012	0.230	5.41	OK
12	0.011	0.230	4.85	OK
13	0.008	0.230	3.48	OK
14	0.008	0.230	3.41	OK
15	0.012	0.230	5.39	OK
16	0.010	0.230	4.38	OK
17	0.014	0.230	6.13	OK
18	0.009	0.230	3.93	OK
19	0.014	0.230	6.22	OK
20	0.011	0.230	4.62	OK
21	0.015	0.230	6.64	OK
22	0.006	0.230	2.69	OK
23	0.019	0.230	8.22	OK
24	0.007	0.230	2.91	OK
25	0.016	0.230	6.84	OK
26	0.003	0.230	1.51	OK
27	0.022	0.230	9.60	OK
28	0.005	0.230	1.96	OK
29	0.013	0.230	5.57	OK
30	0.005	0.230	2.11	OK
31	0.015	0.230	6.63	OK
32	0.006	0.230	2.40	OK
33	0.014	0.230	6.22	OK
34	0.006	0.230	2.70	OK
35	0.013	0.230	5.67	OK
36	0.006	0.230	2.54	OK
37	0.011	0.230	4.71	OK
38	0.005	0.230	2.23	OK
39	0.017	0.230	7.40	OK
40	0.010	0.230	4.28	OK

4.4. Voltage Fluctuations and Flicker on AC Mains Test

RESULT : **Pass**(Please refer to the following page)
Test procedure : EN 61000-3-3:2013
Limits : EN 61000-3-3:2013

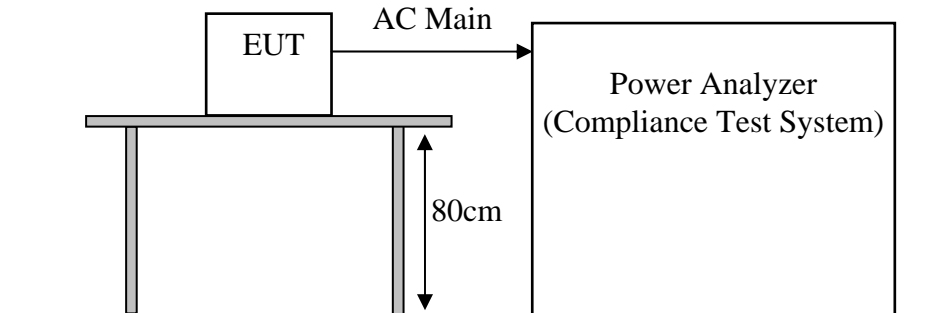

Test Data

Flicker Test Summary per EN/IEC61000-3-3 Ed. 3.0 (2013) (Run time)

EUT: Switching power supply M/N:CRS-C2050-85-08 Tested by: TEA
Test category: All parameters (European limits) Test Margin: 100
Test date: 2019/9/28 Start time: 9:35:51 End time: 9:46:18
Test duration (min): 10 Data file name: F-000592.cts_data
Comment: Full Load
Customer: Channel well

Test Result: Pass

Status: Test Completed

Pst, and limit line

European Limits

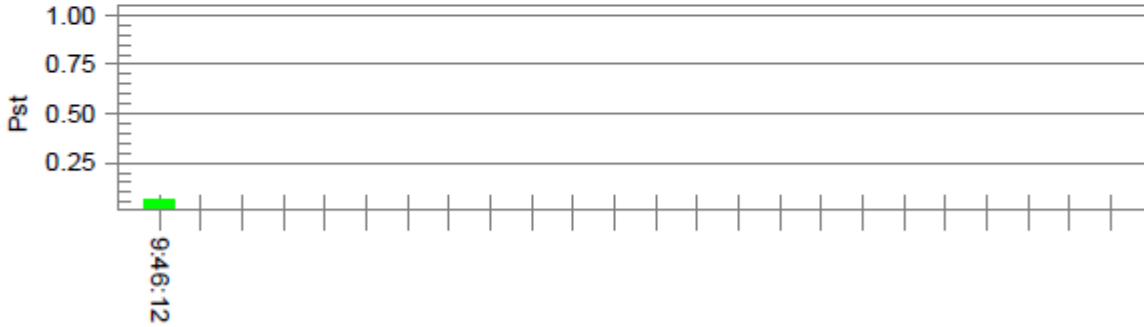

Plt and limit line



Parameter values recorded during the test:

Vrms at the end of test (Volt):	230.42		
T-max (mS):	0	Test limit (mS):	500.0 Pass
Highest dc (%):	0.00	Test limit (%):	3.30 Pass
Highest dmax (%):	0.00	Test limit (%):	6.00 Pass
Highest Pst (10 min. period):	0.064	Test limit:	1.000 Pass
Highest Plt (2 hr. period):	0.028	Test limit:	0.650 Pass

5. IMMUNITY TEST RESULT

5.1. Description of Performance Criteria:

Performance criteria A

During and after the test the EUT shall continue to operate as intended without operator intervention. No degradation of performance or loss of function is allowed below a minimum performance level specified by the manufacturer when the EUT is used as intended. The performance level may be replaced by a permissible loss of performance. If the minimum performance level or the permissible performance loss is not specified by the manufacturer, then either of these may be derived from the product description and documentation, and by what the user may reasonably expect from the EUT if used as intended.

Performance criteria B

After the test, the EUT shall continue to operate as intended without operator intervention. No degradation of performance or loss of function is allowed, after the application of the phenomena below a performance level specified by the manufacturer, when the EUT is used as intended. The performance level may be replaced by a permissible loss of performance.

During the test, degradation of performance is allowed. However, no change of operating state or stored data is allowed to persist after the test.

If the minimum performance level (or the permissible performance loss) is not specified by the manufacturer, then either of these may be derived from the product description and documentation, and by what the user may reasonably expect from the equipment if used as intended.

Performance criteria C

During and after testing, a temporary loss of function is allowed, provided the function is self-recoverable, or can be restored by the operation of the controls or cycling of the power to the EUT by the user in accordance with the manufacturer's instructions. Functions, and/or information stored in non-volatile memory, or protected by a backup, shall not be lost.

5.2. Electrostatic Discharge Immunity Test

RESULT	: Pass
Test procedure	: EN 55024:2010+A1:2015
Basic standard	: EN 61000-4-2:2009
Test specification	: +/-2.0kV ; +/-4.0kV(Contact discharge) +/-2.0kV ; +/-4.0kV ; +/-8.0kV(Air discharge)
Number of discharges	: ≥ 10 (Air discharge for single polarity discharge) ≥ 25 (Contact discharge for single polarity discharge)
Polarity	: Positive/Negative
Performance criterion	: B

Test Setup

Date of test	: Sep. 28, 2019
Model No.	: CRS-C2050-85-08
Input Voltage	: AC 230V/50Hz, AC110V/60Hz
Operation Mode	: Full Load
Temperature	: 22.4°C
Humidity	: 55.1%
Pressure	: 101.1kPa

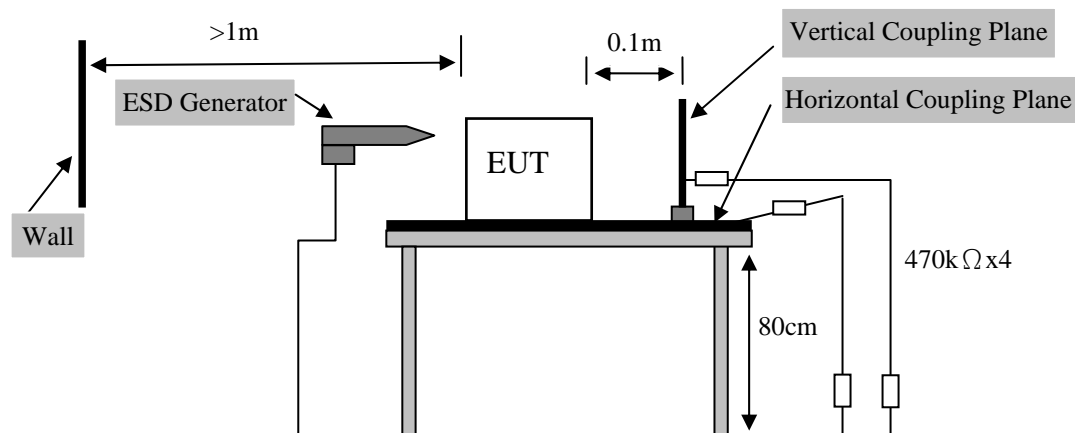

Table 1: Electrostatic Discharge Immunity Test Result

Discharge Location		Type of discharge	Result
HCP	4 points	Contact	Pass
VCP	4 points	Contact	Pass
Slot	1 points	Air	Pass

*Remark: 1. The voltage was reduced during the test, but self-recoverable after the test.
 2. Discharge should be considered on Contact and Air and Horizontal Coupling Plane (HCP) and Vertical Coupling Plane (VCP).*

5.3. Radio Frequency Electromagnetic Field Immunity Test

RESULT : **Pass**
Test procedure : EN 55024:2010+A1:2015
Basic standard : EN 61000-4-3:2006+A1:2008+A2:2010
Performance criterion : A
Test site : 2#966 Chamber

Test Setup

Date of test : Sep. 28, 2019
Model No. : CRS-C2050-85-08
Input Voltage : AC 230V/50Hz, AC110V/60Hz
Operation Mode : Full Load
Temperature : 22.4°C
Humidity : 55.1%
Pressure : 101.1kPa

The EUT and its simulators were placed on a turn table which was 0.8 meter above the ground. The EUT was set 3 m away from the transmitting antenna which was mounted on an antenna tower. Both horizontal and vertical polarization of the antenna were set on test. Each of the four sides of EUT must be faced this transmitting antenna and measured individually.

In order to judge the EUT performance, a CCD camera was used to monitor EUT screen.

All the scanning conditions were as follows:

Condition of Test	Remarks
1. Field Strength	3 V/m (Severity Level 2)
2. Radiated Signal	Modulated
3. Scanning Frequency	80 - 1000 MHz
4. Sweeping time of radiated	0.0015 decade/s
5. Dwell Time	3 Sec.

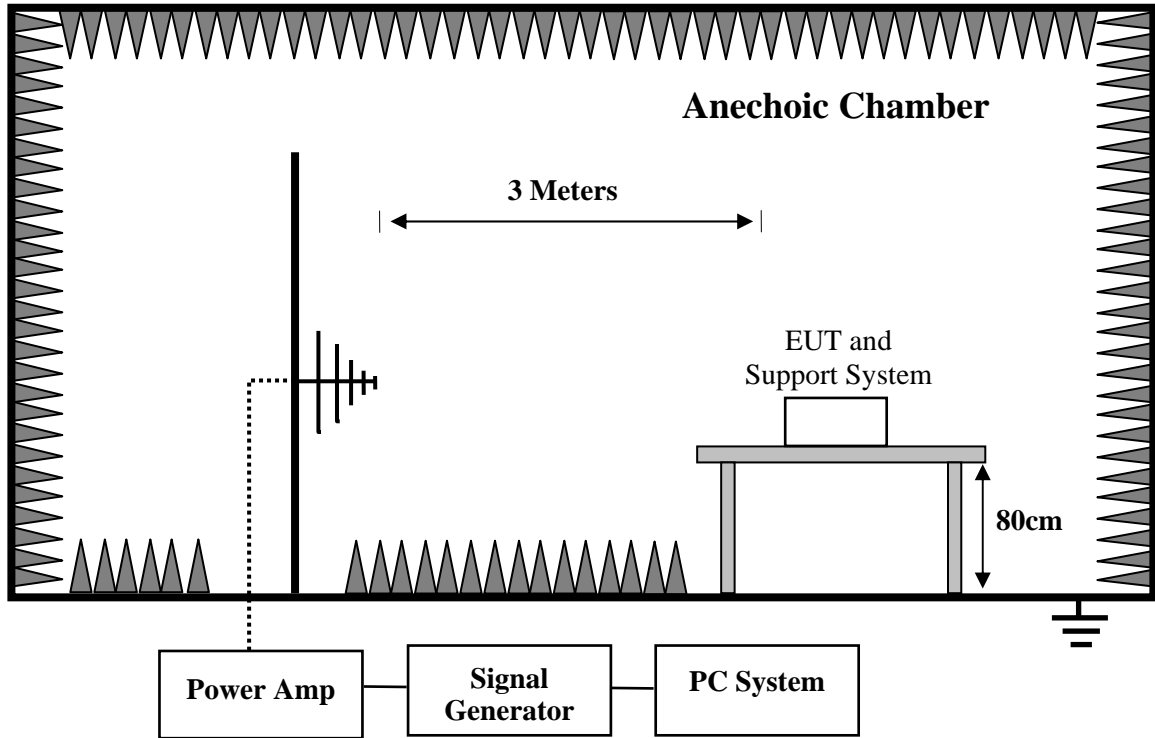

Table 2: Radio Frequency Electromagnetic Field Immunity Test Result

Position	Modulated signal	Test level	Step	Result
Front	AM 80% 1kHz	3 V/m	1%	Pass
Right				Pass
Rear				Pass
Left				Pass

Remark: There was no change compared with initial operation during the test.

5.4. Electrical Fast Transient/Burst Immunity Test

RESULT	: Pass
Test procedure	: EN 55024:2010+A1:2015
Basic standard	: EN 61000-4-4:2012
Pulseform	: Tr/Th = 5/50ns
Repetition Frequency	: 5kHz
Test Duration	: 120s
Performance criterion	: B

Test Setup

Date of test	: Sep. 28, 2019
Model No.	: CRS-C2050-85-08
Input Voltage	: AC 230V/50Hz, AC110V/60Hz
Operation Mode	: Full Load
Temperature	: 22.4°C
Humidity	: 55.1%
Pressure	: 101.1kPa

The EUT and its simulators were placed 0.1m high above the ground reference plane which was a min. 2m*2m metallic sheet with 0.65mm minimum thickness. This reference ground plane shall project beyond the EUT by at least 0.1m on all sides and the minimum distance between EUT and all other conductive structure, except the ground plane beneath the EUT, shall be more than 0.5m.

1. For input and AC power ports:

The EUT was connected to the power mains by using a coupling device which coupled the EFT interference signal to AC power lines. Both polarities of the test voltage should be applied during compliance test and the duration of the test can't less than 2 mains.

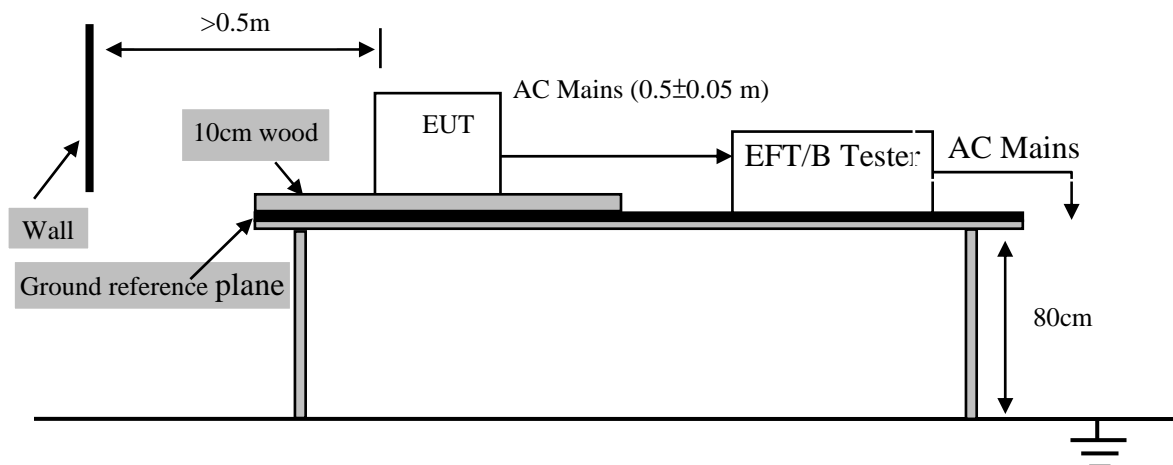

Table 3: Electrical Fast Transient/Burst Immunity Test Result

Coupling Ports		Coupling Voltage	Inject Method	Result
AC Power Ports	L	± 1 kV	Direct	Pass
	N	± 1 kV		Pass
	PE	± 1 kV		Pass
	L-N	± 1 kV		Pass
	L-PE	± 1 kV		Pass
	N-PE	± 1 kV		Pass
	L-N-PE	± 1 kV		Pass

Remark: The voltage was reduced during the test, but self-recoverable after the test.

5.5. Surge Immunity Test

RESULT : **Pass**
Test procedure : EN 55024:2010+A1:2015
Basic standard : EN 61000-4-5:2014
Pulseform : Tr/Td=1.2/50us
Test Duration : 60s
Performance criterion : B

Test Setup

Date of test : Sep. 28, 2019
Model No. : CRS-C2050-85-08
Input Voltage : AC 230V/50Hz, AC110V/60Hz
Operation Mode : Full Load
Temperature : 22.4°C
Humidity : 55.1%
Pressure : 101.1kPa

2 Ω effective output impedance of the generator was used for L-N test. 12 Ω effective output impedance of the generator was used for L-PE,N-PE test.

5 positive and 5 negative (polarity) tests were applied successively synchronized to the voltage phase 0° , 90° , 180° , 270° to L-N respectively. The repetition rate was 1 per minute during test.

1. For input and AC power ports:

The EUT was connected to the power mains by using a coupling device which coupled the surge interference signal to AC power lines. Both polarities of the test voltage should be applied during compliance test and the duration was 1 minute.

2. For signal lines and control lines ports:

None.

3. For DC input and DC output power ports:

None.

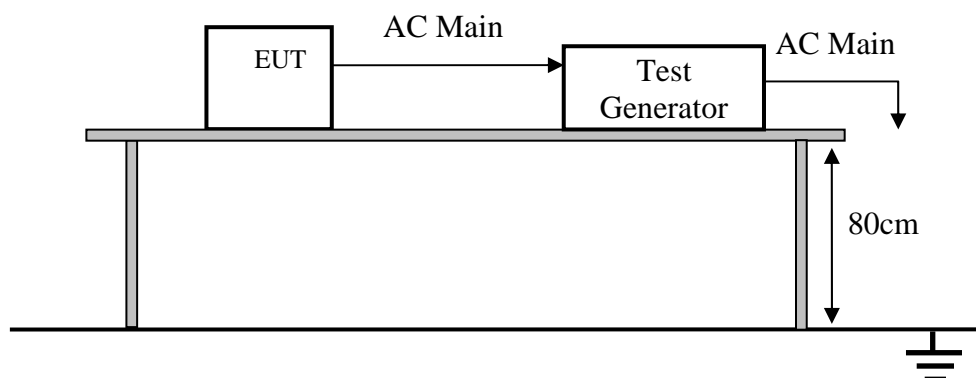

Table 4: Surge Immunity Test Result

Coupling Ports		Coupling Voltage	Coupling Phase / Result			
			0°	90°	180°	270°
AC power ports	L-N	+/-1kV Direct	Pass	Pass	Pass	Pass
AC power ports	L-PE	+/-2kV Direct	Pass	Pass	Pass	Pass
AC power ports	N-PE	+/-2kV Direct	Pass	Pass	Pass	Pass

Remark: The voltage was reduced during the test, but self-recoverable after the test.

5.6. Injected Currents Susceptibility Test

RESULT	: Pass
Test procedure	: EN 55024:2010+A1:2015
Basic standard	: EN 61000-4-6:2014
Test specification	: 3V(r.m.s) unmodulated,1kHz sinusoidal signal, AM 80%, 0.15MHz ~ 80MHz
Performance criterion	: A

Test Setup

Date of test	: Sep. 28, 2019
Model No.	: CRS-C2050-85-08
Input Voltage	: AC 230V/50Hz
Operation Mode	: Full Load
Temperature	: 22.4°C
Humidity	: 55.1%
Pressure	: 101.1kPa

The EUT were placed on an insulating support 0.1m high above a ground reference plane. CDN (coupling and decoupling device) was placed on the ground plane about 0.3m from EUT. Cables between CDN and EUT were as short as possible, and their height above the ground reference plane were between 30 and 50 mm (where possible).

The frequency range was swept from 150KHz to 80MHz using 3V signal level, and with the disturbance signal 80% amplitude modulated with a 1KHz sine wave.

The rate of sweep shall not exceed 1.5×10^{-3} decades/s. Where the frequency was swept incrementally, the step size shall not exceed 1% of the start and thereafter 1% of the preceding frequency value.

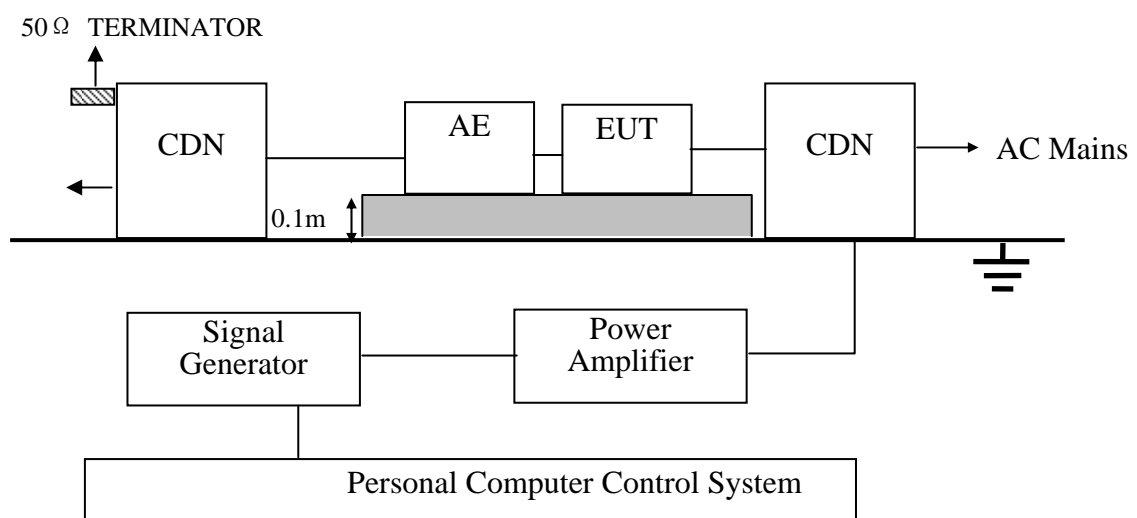

Table 5: Injected Currents Susceptibility Test Result

Coupling ports	Voltage (r.m.s)	Modulation	Freq. step	Dwell time	Coupling method	Result
AC power ports	3V	1kHz AM 80%	1%	1.5s	CDN	Pass
DC power ports	/		/	/	EM Clamp	/
Signal/control	/		/	/	EM Clamp	/

Remark: There was no change compared with initial operation during the test

5.7. Power Frequency Magnetic Field Immunity Test

RESULT : **Pass**
 Test procedure : EN 55024:2010+A1:2015
 Basic standard : EN 61000-4-8:2010
 Test specification : 1 A/m
 Performance criterion : A

Test Setup

Date of test : Sep. 28, 2019
 Model No. : CRS-C2050-85-08
 Input Voltage : AC 230V/50Hz, AC110V/60Hz
 Operation Mode : Full Load
 Temperature : 22.4°C
 Humidity : 55.1%
 Pressure : 101.1kPa

The EUT was subjected to the test magnetic field by using the induction coil of standard dimensions (1m*1m). The induction coil then was rotated by 90° in order to expose the EUT to the test field with different orientations.

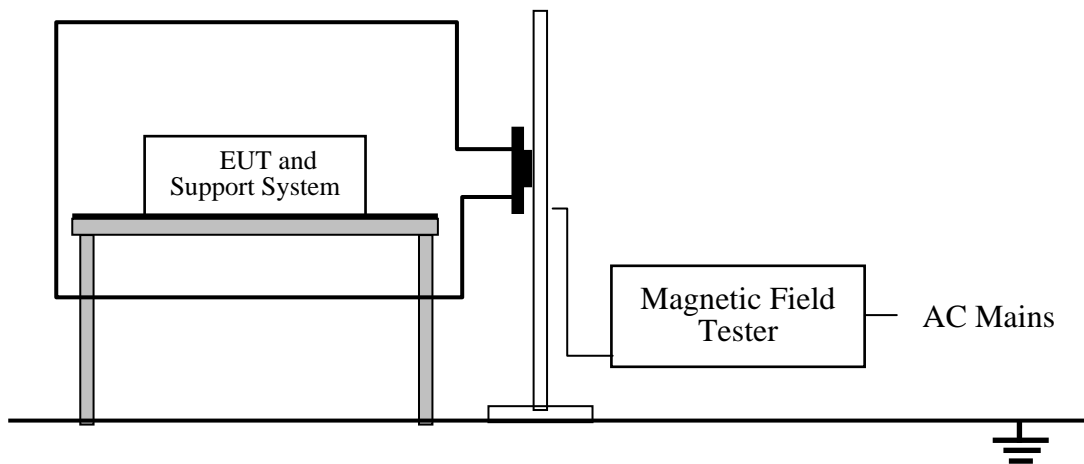

Table 6: Power Frequency Magnetic Field Immunity Test Result

Test Level	Testing Duration	Coil Orientation	Criterion	Result
1A/m	5 mins	X	A	Pass
1A/m	5 mins	Y	A	Pass
1A/m	5 mins	Z	A	Pass

Remark: There was no change compared with initial operation during the test

5.8. Voltage Dips and Short Interruptions Immunity Test

RESULT : **Pass**
Test procedure : EN 55024:2010+A1:2015
Basic standard : EN 61000-4-11:2004
Test specification : 0%UT / 0.5P, Criterion: B
70%UT / 25P, Criterion: C
0%UT / 250P, Criterion: C

Test Setup

Date of test : Sep. 28, 2019
Model No. : CRS-C2050-85-08
Input Voltage : AC 230V/50Hz, AC110V/60Hz
Operation Mode : Full Load
Temperature : 22.4°C
Humidity : 55.1%
Pressure : 101.1kPa

The interruptions was introduced at selected phase angles with specified duration.
Recorded any degradation of performance.

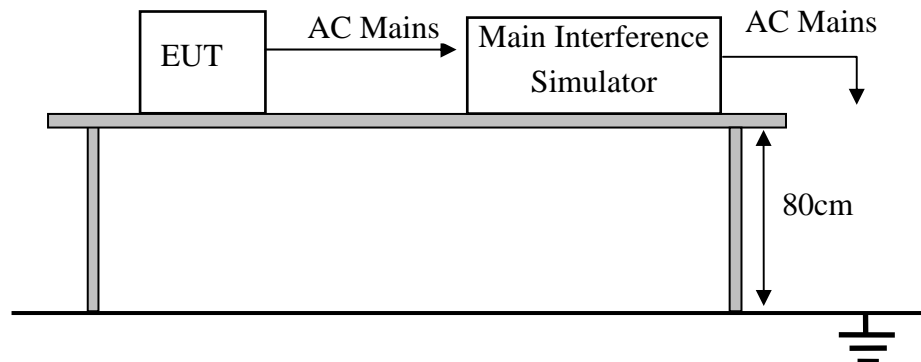

Table 7: Voltage Dips and Short Interruptions Immunity Test Result AC 230V/50Hz

Test Level % UT	Voltage Dips & Short Interruptions % UT	Duration (in period)	Criterion	Result
0	100	0.5P	B	PASS
70	30	25P	C	PASS
0	100	250P	C	PASS

Remark: The voltage was reduced during the test, but self-recoverable after the test.

Table 8: Voltage Dips and Short Interruptions Immunity Test Result AC110V/60Hz

Test Level % UT	Voltage Dips & Short Interruptions % UT	Duration (in period)	Criterion	Result
0	100	0.5P	B	PASS
70	30	30P	C	PASS
0	100	300P	C	PASS

Remark: The voltage was reduced during the test, but self-recoverable after the test.

6. PHOTOGRAPHS OF TEST SET-UP

6.1. Set-up for Conducted Emission at the Mains Terminals Test



6.2. Set-up for Radiated Emission Test

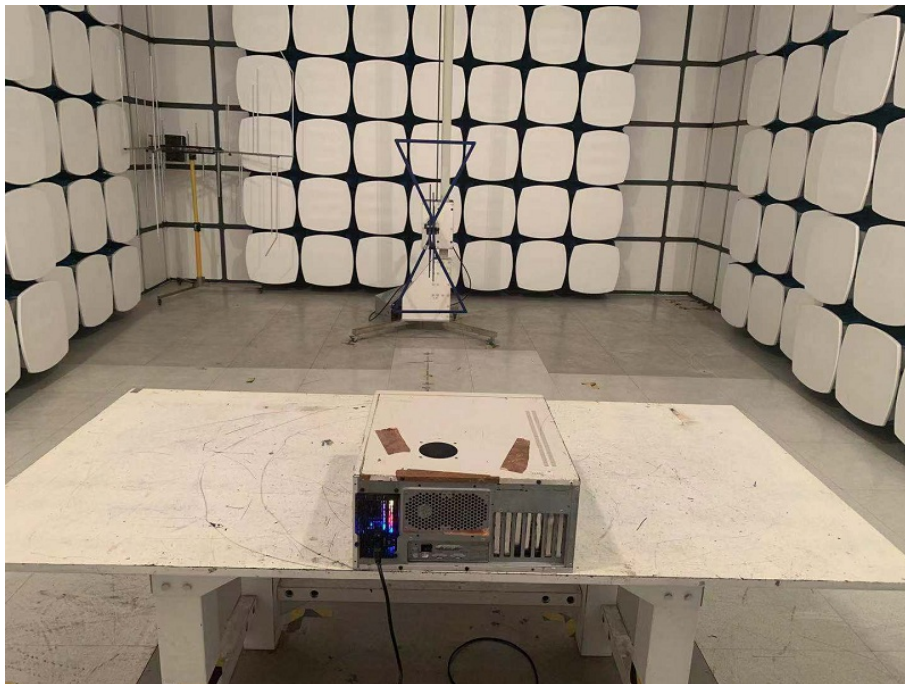

6.3. Set-up for Harmonic Current Emissions and Flicker on AC Mains Test



6.4. Set-up for Electrostatic Discharge Immunity Test



6.5. Set-up for Radio Frequency Electromagnetic Field Immunity Test



6.6. Set-up for Electrical Fast Transient/Burst Immunity Test



6.7. Set-up for Surge Immunity Test



6.8. Set-up for Injected Currents Susceptibility Test



6.9. Set-up for Power Frequency Magnetic Field Immunity Test

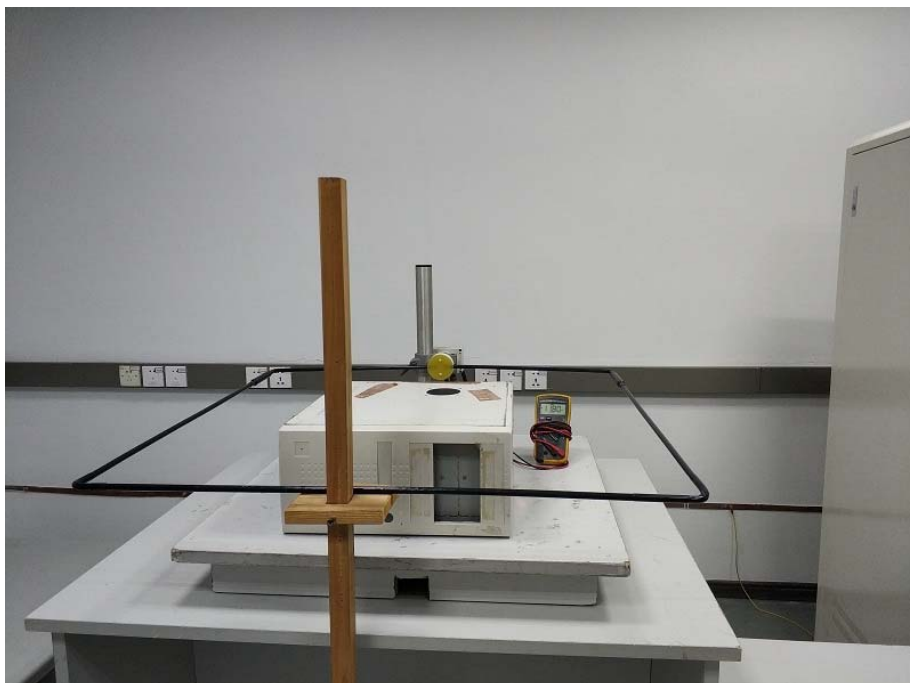

6.10. Set-up for Voltage Dips and Short Interruptions Immunity Test



7. PHOTOGRAPHS OF THE EUT

Figure 1
General Appearance of the EUT



Figure 2
General Appearance of the EUT



Figure 3
General Appearance of the EUT



Figure 4
General Appearance of the EUT



Figure 5
Inside View of the EUT



Figure 6
Inside View of the EUT

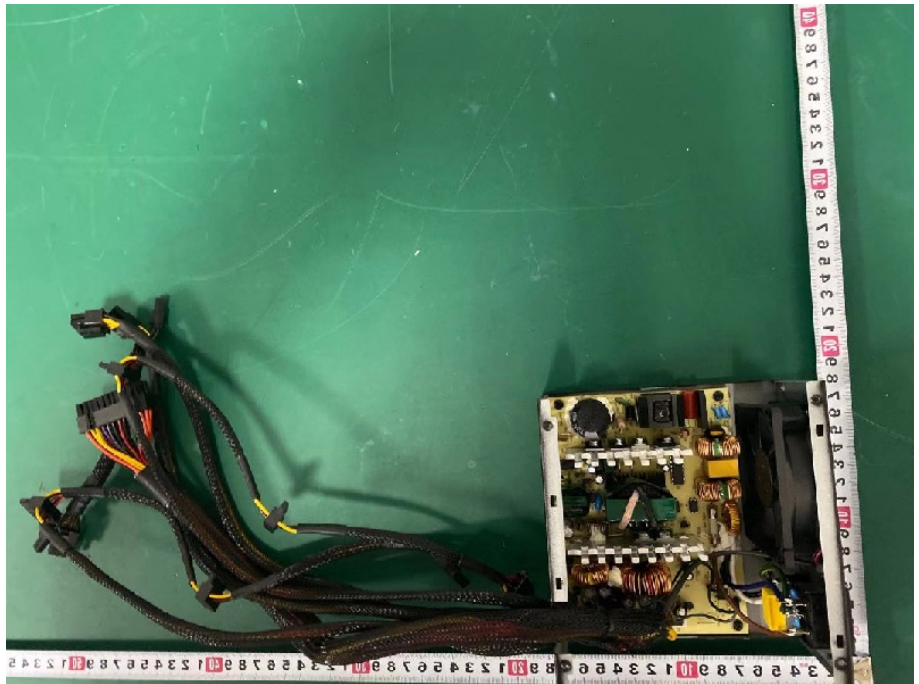

Figure 7
Inside View of the EUT

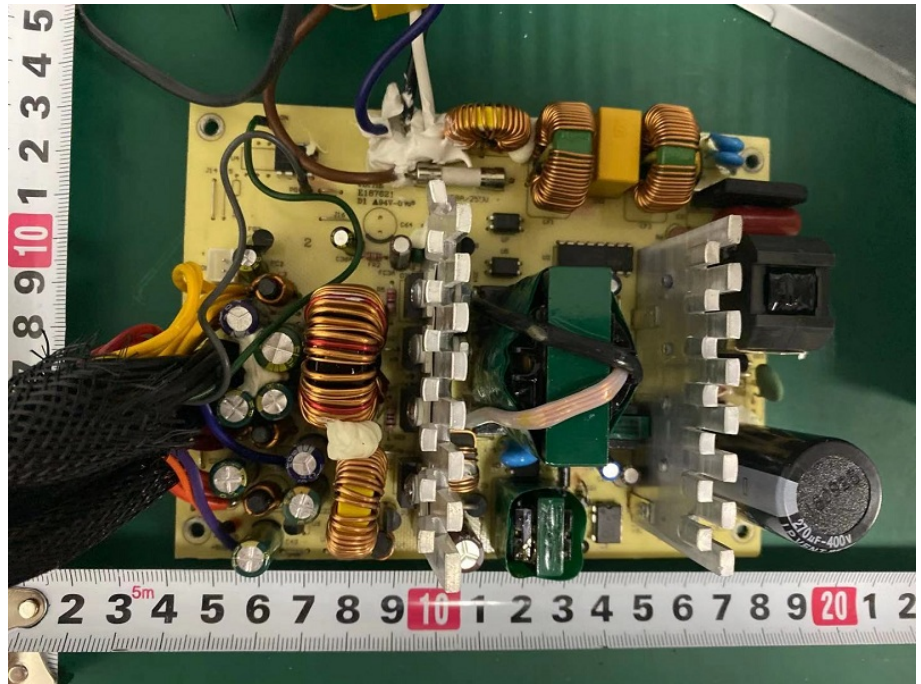

Figure 8
Inside View of the EUT

