

1 Scopes and Definition

This specification defines the performance characteristics of a single-phase (3-wire) 500W single output power supply with wide range input AC capability (100-240VAC/50-60Hz) under operation temperature 50 degree C. The power supply shall be designed for parallel operation. In the event of a power supply failure, the redundant power supply continues to power the system even under over voltage fault. The number of power supplies per system will be limited to a maximum of four. The power supply shall be designed for “hot swap” exchange and must contain the OR-ing isolation MOSFETs for all outputs and shall communicate to external devices through Inter-Integrated (I2C) Circuit protocol. The power supply will have an EEPROM for storing powers supply FRU information, and meet PMBus Revision 1.2 requirement.

2 Input Requirement

2.1 AC Input Requirements

The Power supply must be have a universal power input with active power factor correction to reduce the line harmonics in accordance with the EN61000-3-2 standard, see section 9 for detailed regulatory standards.

The power supply must be capable of operating with the following Conditions

	Minimum	Nominal	Maximum	Unit
Input Voltage Range(Vac)	85	100/230	264	Vac
Input Frequency(Hz)	47	60/50	63	Hertz
Input Current(A)	11	9/4	3.5	Amperes

The unit must not go into hiccup mode when in the boundary of turn on voltage threshold, an ACUV circuit is recommended.

2.2 Power Factor

The power supply must have a minimum 0.96 and 0.98 at 115Vac measured with 20% and 80% load respectively; and minimum 0.92, 0.95 and 0.97 at 230Vac measured with 20%, 50%, and 100% of max load respectively.

2.3 Inrush Current

When input AC power is applied to the power supply any initial current surge or spike of 10ms or less will not exceed 25A peak. Any additional inrush current surges or spikes in the form of AC cycles or multiple AC cycles greater than 10ms, and less than 150ms, must not exceed 15A peak. After 150ms the AC input current must meet the input AC current requirements 2.1

For any conditions during turn-on the inrush current will not open the primary input fuse or damage any other components.

2.4 Efficiency & THD

The power supply must have a minimum of 90% Efficiency measured at 20% of max load with nominal input AC voltage condition (100-240Vac) and it shall have **minimum 94% peak efficiency at 175W** for 230Vac input without fan power. Also efficiency should be meet climate saver targets **Platinum** level as below (AC input 230Vac only).

Loading(without fan power)	Efficiency	PF	THD (input current)
10%	82%	0.80	< 15%
20%	90%	0.92	< 10%
50%	94%	0.95	< 5%
100%	91%	0.97	< 5%

2.5 Input fuse

The Input fuse must be slow blow or normal blow high breaking type.

2.6 Input Receptacle

The AC input receptacle must be approved by Product Safety Regulatory Agencies and must be rated properly for current, voltage and temperature. The AC input connector shall be an IEC 320 C-14 power inlet.

Add cable clamp on PS chassis: the Power supply chassis needs to open one hole for AC cable clamp.

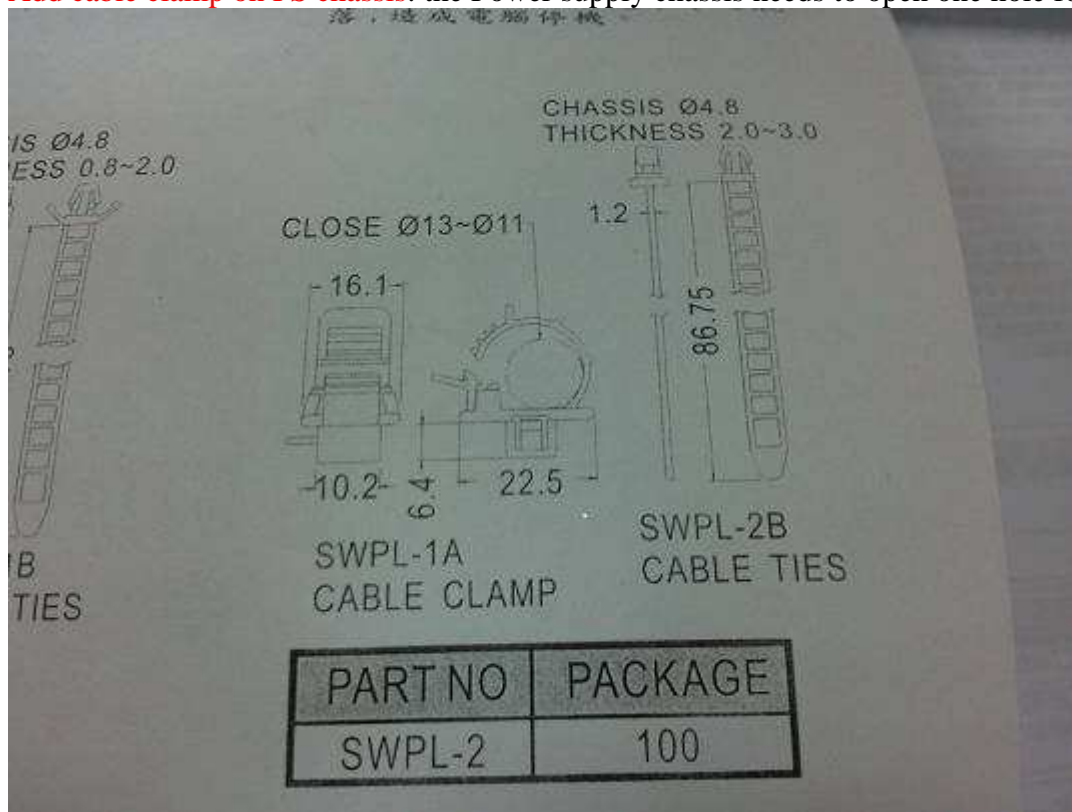

2.7 Input Under Voltage

The power supply shall contain protection circuitry such that application of an input voltage below the minimum specified in section 2.1 shall not cause damage to the power supply. Input voltage range for AC minimum startup voltage, 84-87VAC, and maximum turn off voltage range 79 to 83VAC.

2.8 AC Line Transient Specification

AC line transient conditions shall be defined as “sag” and “surge” conditions. Sag conditions (also referred to as “brownout” conditions) will be defined as the AC line voltage dropping below nominal voltage. Surge will be defined as the AC line voltage rising above nominal voltage.

The power supply shall meet the requirements under the following AC line sag and surge conditions.

Table 1: AC Line Sag Transient Performance

Duration	Sag	Operating AC Voltage	Line Frequency	Performance Criteria
Continuous	10%	Nominal AC Voltage ranges	50/60 Hz	No loss of function or performance
0 to 1 AC cycle	100%	Nominal AC Voltage ranges	50/60 Hz	No loss of function or performance with system load.
> 1 AC cycle	>10%	Nominal AC Voltage ranges	50/60 Hz	Loss of function acceptable, self-recoverable

Table 2: AC Line Surge Transient Performance

Duration	Surge	Operating AC Voltage	Line Frequency	Performance Criteria
Continuous	10%	Nominal AC Voltages	50/60 Hz	No loss of function or performance
0 to ½ AC cycle	30%	Mid-point of nominal AC Voltages	50/60 Hz	No loss of function or performance

2.9 AC Line Surge Specification

The power supply shall meet the EN61000-4-5 directive and any additional requirements in IEC1000-4-5:1995 and the Level 3 requirements for surge-withstand capability, with the following conditions and exceptions:

- These input transients must not cause any out-of-regulation conditions, such as overshoot and undershoot, nor must it cause any nuisance trips of any of the power supply protection circuits.
- The surge-withstand test must not produce damage to the power supply.
- The supply must meet surge-withstand test conditions under maximum and minimum output load conditions.

3 Output Requirements

3.1 Output regulation Requirements

All outputs must maintain their regulation with the below limits when measured at the output connector point or across the remote sense (if applicable) in any load condition defined in **section 3.2**

Output	Minimum	Nominal	Maximum	Unit
+12V	11.5	12.	12.5	Vdc
+5Vsb	4.8	5.0	5.25	Vdc

+12V output voltages must lower than 50mV when PS is operating on stand-by mode, 5Vsb.

3.2 Output Current Requirements

All outputs must maintain their regulation as per **section 3.1** when loaded to the following loading combination:

Output	Minimum	Maximum	Unit	Input VAC
+12V	0.2	41.7	Adc	90 to 264
+5Vsb	0	4.0	Adc	90 to 264

The total output power can not exceed 500W continuously for 90 to 264VAC input. During load changes from minimum to maximum or maximum to minimum or no load the unit must not shut down or damage.

3.3 Output Ripple and Noise

The following output ripple/noise requirements will be met throughout the load ranges specified in **section 3.2** and under all input voltage conditions specified in **section 2.1**.

Ripple and noise are defined as periodic or random signals over the frequency band of 10Hz to 20MHz. Measurements will be made with an oscilloscope set to 20MHz bandwidth limit. Measurement is done by using 10uF Tantalum in parallel with a 0.1uf ceramic capacitor, measured directly at the output connector side (Note: care must be taken when doing measurements such as using the smallest grounding wire.).

Output	Maximum	Unit
+12V	120	mV
+5Vsb	50	mV

3.4 Output Dynamic Loading

The output voltages shall remain within the limits specified in **section 3.1** for the step loading and within the limits specified in **section 3.5** for the capacitive loading. The load transient repetition rate shall be tested between 50 Hz and 10 kHz at duty cycles ranging from 10%-90%. The load transient repetition rate is only a test specification. The Δ step load may occur anywhere within the MIN load to the MAX load shown in **section 3.2**

3.4 Transient Load Requirements

Output	Δ Step Load Size	Load Slew Rate	Capacitive Load
12V	65% of max load	0.5 A/ μ s	2200 μ F
+5 VSB	25% of max load	0.5 A/ μ s	1 μ F

3.5 Capacitive Loading

The power supply shall be stable and meet all requirements with the following capacitive loading ranges.

3.5 Capacitive Loading Conditions

Output	MIN	MAX	Units
+12 V	10	11,000	μ F
+5 VSB	1	350	μ F

4 Redundancy Requirements

4.1 Current Sharing Operation

The power supply shall be designed for active current sharing.

Two or more than two power supplies will be paralleled in a system. Each power supply must be able to share load to within +/-10 % share error measured 25, 50, 100% of single power supply full load current. 5Vsb requires an "ORing" diode or FET to provide protection against internal short circuit fault.

4.2 Output Isolation Oring MOSFET

The 12V output current must pass through an Oring MOSFET to protect the bus voltage against a power supply internal fault.

4.3 Power Supply Behavior When Faulted

- 1 The faulted supply shall not sink more than 100 mA current.
- 2 I2C bus status shall be operational and valid, refer to “I2C Bus/VPD Interface”.
- 3 The "DC Good" signal and "DC Good Fault" bit status shall be valid.
- 4 A power supply that fails due to a 12V or 5Vsb Over-Voltage condition will shutdown gracefully and will not cause shutdown of the other power supplies in parallel.
- 5 The power supply has to save 5 latest records of the abnormal shutdown on the EEPROM. The record is a byte data format, and its definition is shown below. The record should be clear before the shipping.

```
#define (reserved)          0x01
#define PRIMARY_OTP        0x02
#define SECONDARY_OTP      0x03
#define (reserved)          0x04
#define SCP_FAULT          0x05
#define OCP_FAULT_220V     0x06
#define OCP_FAULT_110V    0x07
#define OVP_FAULT          0x08
#define DC12V_OVP_FAULT    0x09
#define DC12V_UVP_FAULT    0x0A
#define AC_LOSS            0x0B
#define FAN2_FAULT         0x0C
#define FAN1_FAULT         0x0D
#define OPP_FAULT          0x0E
#define OTHER_FAULT        0x0F
```

The failure black box information should be put into EEPROM I2C address 0x70, 0x72, 0x74, 0x76 at offset 0xFA-0xFE

4.4 Parallel Stability

The power supply shall be unconditionally stable under any system load even no load condition and AC line conditions while operating alone or in parallel mode.

4.5 Hot Swap

The power supply must be designed with “hot swap” function with or without active AC line cord. After Hot swap I2C address shall be same as host power supply backplane hardware assigned. Host existing working power supply shall not be affected by hot swapping power supply.

5 Controls and Signal

5.1 Timing Requirements

These are the timing requirements for the power supply operation. The output voltages must rise from 10% to 90% within regulation limits (T_{vout_rise}) within 5 to 13 ms.

Each output voltage shall reach regulation within 50 ms (T_{vout_on}) of each other during turn on of the power supply. Each output voltage shall fall out of regulation within 400 ms (T_{vout_off}) of each other during turn off. Figure 1 and Figure 2 the turn ON and turn OFF timing requirements. In Figure 2, the timing is shown with both AC and PSON# controlling the ON/OFF of the power supply.

Item	Description	MIN	MAX	Units
T_{vout_rise}	Output voltage rise time from each main output.	5	13	ms
T_{vout_on}	All main outputs must be within regulation of each other within this time.		13	ms
T_{vout_off}	All main outputs must leave regulation within this time.		400	ms

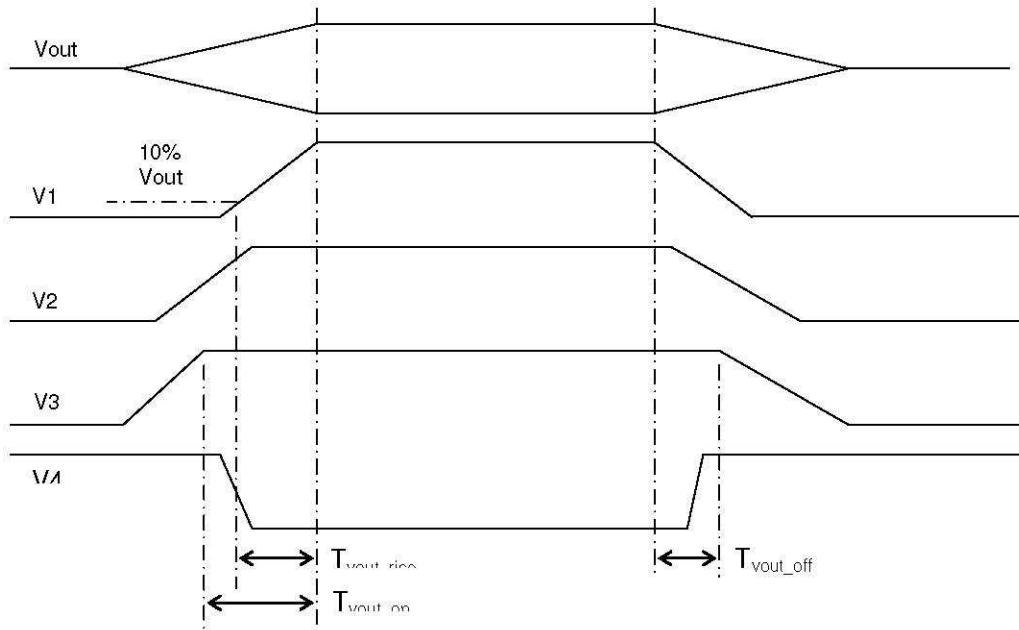
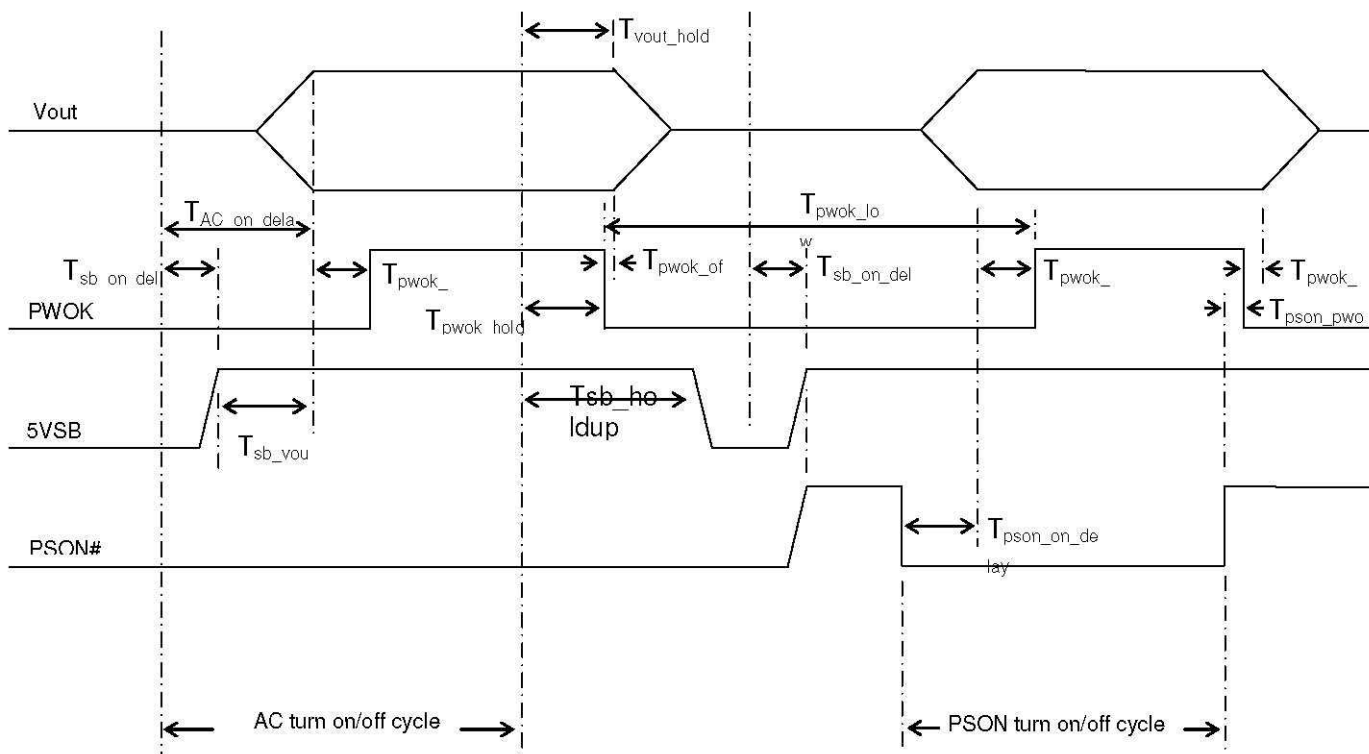

Fig. 1 Output Voltage Timings

AC Input



Note: PWOK = dc_good signal

Figure 2 Turn On/Off Timing (Signal Power Supply)

Item	Description	MIN	MAX	Units
Tsb_on_delay	Delay from AC being applied to 5 VSB being		1500	ms

	within regulation.			
T _{ac_on_delay}	Delay from AC being applied to all output voltages being within regulation.		2500	ms
T _{vout_holdup}	Time all output voltages stay within regulation after loss of AC at 75% load	18		ms
T _{dc_good_holdup}	Delay from loss of AC to deassertion of DC Good	16		ms
T _{pson_on_delay}	Delay from PSON# active to output voltages within regulation limits.	5	400	ms
T _{pson_dc_good}	Delay from PSON# deactive to DC Good being deasserted.		50	ms
T _{dc_good_on}	Delay from output voltages within regulation limits to DC Good asserted at turn on.	100	110	ms
T _{dc_good_off}	Delay from DC Good deasserted to output voltages dropping out of regulation limits.	2		ms
T _{dc_good_low}	Duration of DC Good being in the deasserted state during an off/on cycle using AC or the PSON# signal.	100		ms
T _{sb_vout}	Delay from 5 VSB being in regulation to O/Ps being in regulation at AC turn on.	50	500	ms
T _{sb_holdup}	Time 5VSB output voltage stays within regulation after loss of AC.	70	800	ms
T _{sb_Vout_rise}	The rising time for +5VSB start up to be in regulation	1	25	ms

5.2 PS_ON

The PSONsignal is required to remotely turn on/off the power supply. PSON is an active low signal that turns on the +12 V power rail. When this signal is not pulled low by the system, or left open, the outputs (except the +5 VSB and Vbias) must be off. This signal is pulled to 5V standby voltage by a pull-up resistor internally.

Table 3: PSON Signal Characteristic

Signal Type	Accepts an open collector/drain input from the system. Pull-up to 5VSB located in power supply.	
PSON# = Low	ON	
PSON# = Open or High	OFF	
	MIN	MAX
Logic level low (power supply ON)	0 V	1.0 V
Logic level high (power supply OFF)	2.0 V	5.25 V
Source current, V_{pson} = low		4 mA
Power up delay: T_{pson_on_delay}	5 ms	400 ms
PWOK delay: T_{pson_pwok}		50 ms

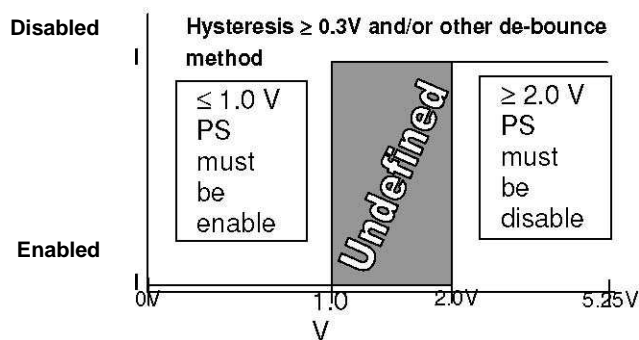

Fig.3 Logic level definition

5.3 DC_GOOD

DO_Good is a power OK signal and will be pulled HIGH by the power supply to indicate that all the outputs are within the regulation limits of the power supply. When any output voltage falls below regulation limits or when AC power has been removed for a time sufficiently long so that power supply operation is no longer guaranteed, DC_Good will be de-asserted to a LOW state.

Table 4: DC_GOOD Signal Characteristics

Signal Type	+12V Compatible output signal	
DC_GOOD= High	Power OK	
DC_GOOD = Low	Power not OK	
	MIN	MAX
Logic level low, Isink = 4mA		0.4 V
Logic level high, Isource = 200µA	9.4 V	12.25 V
DC_GOOD delay: T_{dcgood_on}	100 ms	110 ms
DC_GOOD rise and fall time		100 µs

5.4 AC Warning

Noted on PMBus standard.

5.5 LED Indicator

A green/amber double color Light Emitting Diode (LED) shall be mounted as indicated in mechanical drawing and shall indicate the status of the DC GOOD signal with green color. The LED shall continue to glow under normal operation of the power supply. If this LED is blinking or not lit or in amber color, the power supply is not operating properly.

5.6 Power Leakage

The leakage voltage of +12V and DC GOOD signal even connected with PDB to power +5V, +3.3V, -12V must less than 50mV when PS is operating on 5Vsb mode only.

Any combination in one system with 4 redundant power supplies; AC leakage current is less than 3.5mA for total.

The AC leakage current must be less than 1.2mA for signal PS.

6 I²C and PMBus™ 1.2 standard.

6.1 I²C to meet Super Micro standard.

This power support supports both Super Micro I2C function and PMbus. With different addressing, the user should be able to use either Super Micro I2C FRU or PMbus commands.

6.1.1 Super Micro I2C

Slave address will be 0x70 (default), 0x72, 0x74, 0x76

The power supply can be read and written to as if it's an 2k bit (256 byte) I2C EEPROM. The power supply must support: Byte write and Random read. Read and write must work at speeds up to 100 kHz. This bus shall operate at 3.3V but be tolerant of 5V signaling.

All the data stored in the power supply follows FRU spec, IPMI, Platform Management FRU information Storage Definition v1.0.

FRU spec attached below:

Platform Management FRU Information Storage Definition

- 17. FRU Information Layout..... 15
- 18. Record Field Definitions 16
 - 18.1 Power Supply Information (Record Type 0x00) 16
 - 18.1.1 Overall Capacity in Watts 16
 - 18.1.2 Peak VA 17
 - 18.1.3 Inrush 17
 - 18.1.4 Inrush interval..... 17
 - 18.1.5 Low end Input voltage range 1 17
 - 18.1.6 High end Input voltage range 1 17
 - 18.1.7 Low end Input voltage range 2 17
 - 18.1.8 High end Input voltage range 2 17
 - 18.1.9 Low end input frequency range 17
 - 18.1.10 High end input frequency range 17
 - 18.1.11 A/C dropout tolerance 17
 - 18.1.12 Binary flags 17
 - 18.1.12.1 Tachometer pulses per rotation/Predictive fail polarity 17
 - 18.1.12.2 Other Binary flags..... 18
 - 18.1.13 Peak Wattage 18
 - 18.1.14 Combined Wattage..... 18
 - 18.1.15 Predictive fail tachometer lower threshold 18
 - 18.2 DC Output (Record Type 0x01) 19
 - 18.2.1 Output Information..... 19
 - 18.2.2 Nominal voltage 19
 - 18.2.3 Maximum negative voltage deviation 20
 - 18.2.4 Maximum positive voltage deviation 20
 - 18.2.5 Ripple and Noise pk-pk, 10Hz to 30MHz 20
 - 18.2.6 Minimum current draw 20
 - 18.2.7 Maximum current draw 20
 - 18.3 DC Load (Record Type 0x02)..... 20
 - 18.3.1 Output Information..... 20
 - 18.3.2 Nominal voltage 20
 - 18.3.3 Spec'd minimum voltage 20
 - 18.3.4 Spec'd maximum voltage 21
 - 18.3.5 Ripple and Noise pk-pk, 10Hz to 30MHz 21
 - 18.3.6 Minimum current load 21
 - 18.3.7 Maximum current load 21
 - 18.4 Management Access Record (Record Type 0x03) 21
 - 18.4.1 Example 22
 - 18.5 Base Compatibility Record 24

iv

The “Chassis Info” and “Board Info” are not to be implemented. The “Common Header” and “Product Area” are required.

For the “Multiple Record” area, the power supply should implement the “Power Supply Information”(section 18.1), and multiple “DC Output” section as needed.

For the “Product Info” area must began from offset location 0x18 (offset 0x04 product information offset must contains value of 0x03).

The “Internal Use” section, defined by Supermicro as follows:

Offset		Result of a read
0x09	Temperature	Value to represent the current temperature of the hottest spot inside the power supply This is an unsigned integer value in Celsius.
0x0A	Fan 1 speed (main fan)	Value to represent the RPM of the power supply fan #1 This should be the fan pulse count in 262 ms.

		<p>We are assuming that two fan pulses equal one rotation.</p> <p>The system software will convert this value, to fan RPM, using:</p> $\text{RPM} = (1/0.262) * (\text{Fan Pulse Count} * 60 / 2)$
0x0B	Reserved	
0x0C	Power Status	<p>Value to represent DC GOOD status</p> <p>byte = hex 01 means DC GOOD</p> <p>byte = 00 means no DC output</p>
0x0D	Temperature High Limit	Value is fixed and should be the highest acceptable temperature that the power supply can sustain based on offset 09.
0x0E	Fan 1 speed Low Limit	Value is fixed and should be the lowest fan #1 RPM acceptable
0x0F	Reserved	
0x10	Reserved	
0x11	Reserved	
0x12	Reserved	
0x13	Reserved	
0x14	AC RMS current	This byte, divided by 16, is the AC (RMS) input current.
0x15	Reserved	
0x16	Firmware version	<p>Example: version 2.0 is encoded as 0x20</p> <p>The smallest version number allowed is 2.0</p> <p>Anything less than 2.0 (0x20) found at this location will be reported as version 1.0 by Supermicro health monitoring software</p>
0x17	FRU file revision	Integer only
0xF0	AC current limit	AC current upper limit; same scale factor as 0x14
0xF1	+12V DC current limit	+12V DC current upper limit; scale factor: this byte, divided by 2, is the DC (+12V) output current.
0xF2	Power supply wattage	Power supply wattage; lower byte
0xF3		Power supply wattage; higher byte
0xF4	Input voltage	100-240Vac input voltage reading
0xF5	Input power	Input power in watt (lower byte) (0x0864=360W)
0xF6	Input power	Input power in watt (higher byte)
0xFF	Write protection Control	<p>This byte controls whether the FRU is writeable or read only. When this byte content is 0x88, the FRU is writeable. Otherwise, only byte 0xFF can be modified.</p> <p>value= 0x88 is FRU writeable mode</p> <p>Any other value, FRU is read only except address 0xFF can be modified.</p> <p>Default value for this byte is read only, 0x00.</p>

The power supply will support the “byte write” procedure defined in the I2C EEPROM spec.

Read only bytes --- writes to the following bytes should be ignored:

Offset	
0x09	Temperature
0x0A	Fan 1 speed (main fan)
0x0B	Fan 2 speed (secondary fan if available)
0x0C	Power Status
0x14	AC RMS current
0xF4	Input voltage
0xF5	Input power (lower byte)
0xF6	Input power (higher byte)

I2C auto-recovery feature:

In a normal I2C transaction, there will be 8 bytes of transmission plus an ACK (acknowledge) byte, for a total of 9 clock cycles. ACK is done by pulling down the SDA line. If there is a missing clock cycle, the chip doing the ACK will hold down the SDA line indefinitely and hanging the I2C bus. The power supply needs to prevent the above scenario from happening. If the I2C bus SDA or SCL is stuck low for more than 25 ms, the power supply should reset either its I2C communication module, or itself.

The power supply I2C microcontroller should not latch the system I2C bus by pulling SDA or SCL line low for more than 25 ms.

The power supply needs to have 4.7k Ohm internal pull up on the SDA or SCL lines and operate with 3.3V nominal voltage level.

6.1.2 PMBus

The PMBus specification is based on the PMBus specification parts I and II, revision 1.1 and 1.2. PMBus Power System Management Protocol Specification Part I – General Requirements, Transport and Electrical Interface; Revision 1.2; Reference: <http://pmbus.org/specs.html>

PMBus Power System Management Protocol Specification Part II – Command Language; Revision 1.2; Reference: <http://pmbus.org/specs.html>

System Management Bus (SMBus) Specification version 2.0; Reference: <http://smbus.org/specs/>

6.2.A Addressing

The power supply PMBus device address locations are shown below. For redundant systems there are up to 2 signals to set the address location of the power supply once it is install in the system: A1, A0. For no-redundant systems the power supply device address location should be 78h.

System addressing Address1/Address0	0/0	0/1	1/0	1/1
Power supply PMBus™ device	78h	7Ah	7Ch	7Eh

Note: Non-redundant power supplies will use the 0/0 address location.

6.2.B Hardware

The device in the power supply shall be compatible with both SMBus 2.0 ‘high power’ specification for I²C V_{dd} based power and drive (for V_{dd} = 3.3V). This bus shall operate at 3.3V but be tolerant of 5V signaling.

One pin is the Serial Clock [SCL] (PSM Clock). The second pin is used for Serial Data [SDA] (PSM Data). Both pins are bi-directional, open drain signals, and are used to form a serial bus. The circuits inside the power supply shall derive their power from the standby output.

The PMBus device shall be on whenever AC power is applied to the power supply or a parallel redundant power supply in the system.

1000ns maximum rise time for SDA and SCL

300ns maximum fall time with a 400pF capacitive load for SDA and SCL

10ns minimum fall time with a 20pF capacitive load for SDA and SCL

The power supply needs to have 4.7k Ohm internal pull up to 3.3V on the SDA or SCL lines and operate with 3.3V nominal voltage level.

6.2.C Data Speed

The PMBus device in the power supply shall operate at 100khz and avoid using clock stretching that can slow down the bus. For example, the power supply can clock stretch while parsing a command or a power supply servicing multiple internal interrupts or NACK may require some use of clock stretching.

Unsupported commands may respond with a NACK but must always set the communication error status bit in STATUS_CML.

The PMBus device shall support SMBus cumulative clock low extend time (T_{low: sext}) if < 25ms. This requires the device to extend the clock time no more than 25ms between START and STOP for any given message.

6.2.D Bus Errors

The PMbus device shall support SMBus clock-low timeout (T_{timeout}). This capability requires the device to abort any transaction and drop off the bus if it detects the clock being held low for > 25ms, and be able to respond to new transaction 10ms later.

The device must recognize SMBus START and STOP conditions on any clock interval. (These are requirement of the SMBus specifications, but are often missed in first-time hardware designs.) The device must not hang due to ‘runt clocks’, ‘rut data’, or other out-of-spec bus timing. This defined as signals, logic-level glitches, setup or hold times that are shorter than the minimums specified by the SMBus specification. The device is not required to operate normally, but must return to normal operation once ‘in spec’ clock and data timing is again received. Note if the device ‘misses’ a clock from the master due to noise or other bus errors, the device must continue to accept ‘in spec’ clocks and re-synch with the master on the next START or STOP condition.

6.2.E Command

The following PMBus commands shall be supported for the purpose of monitoring currents, voltages, and power. All data should use the linear data format as documented in PMBus spec.

The Linear Data Format is a two byte value with:

- An 11 bit, two's complement mantissa and
- A 5 bit, two's complement exponent (scaling factor).

The format of the two data bytes is illustrated in Figure 4.

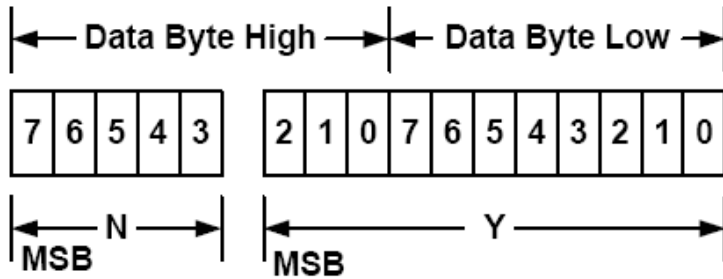

Figure 4. Linear Data Format Data Bytes

The relation between Y , N and the “real world” value is:

$$X = Y \cdot 2^N$$

Where, as described above:

X is the “real world” value;

Y is an 11 bit, two's complement integer; and

N is a 5 bit, two's complement integer.

Devices that use the Linear format must accept and be able to process any value of N .

<u>PMBus command</u>	Command Offset location	Byte size	<u>Description</u>
<u>CLEAR_FAULTS</u>	0x03	1	Writing any value into this byte will reset all the fault status
<u>PAGE_PLUS_WRITE</u>	0x05	variable	used with STATUS_INPUT, STATUS_TEMPERATURE, STATUS_IOUT
<u>PAGE_PLUS_READ</u>	0x06	Variable	used with STATUS_INPUT, STATUS_TEMPERATURE, STATUS_IOUT, STATUS_WORD
CAPABILITY	0x19	1	Provides a way for a host system to determine some key capabilities of a PMBus device
QUERY	0x1A	1 with block write read	Used to determine if the power supply supports a specific command
SMBALERT_MASK	0x1B	Variable	Used to prevent a warning or fault condition from asserting the SMBALERT# Signal. The masks can be changed by user.
VOUT_MODE	0x20	1	determines the format of Voltage output (Linear, direct, or VID), also set the mantissa

COEFFICIENT	0x30	5 with block write read	The system shall use this to read the values of m, b, and R used to determine READ_EIN accumulated power values.
FAN_CONFIG_1_2	0x3A	1	Returns the configuration of Fan 1 and Fan 2 in the power supply
FAN_COMMAND_1	0x3B	2	Allows system to request fans in the power supply to be set to the defined duty cycle. The system cannot cause the power supply fan to run slower than the power supply needs for cooling. This data should be in linear format. Example (32h=50% duty, 64h=100% Duty)
FAN_COMMAND_2	0x3C	2	Allows system to request fans in the power supply to be set to the defined duty cycle. The system cannot cause the power supply fan to run slower than the power supply needs for cooling. This data should be in linear format. Example (32h=50% duty, 64h=100% Duty)
STATUS_BYTE	0x78	1	command to report the On/off status of the power supply. Please refer to page 72 of PMbus spec part 2
STATUS_WORD	0x79	2	command to report the 2byte status of the power supply. Please refer to page 74 of PMbus spec part 2
STATUS_IOUT	0x7B	1	command to report the output current status
STATUS_INPUT	0x7C	1	command to report the input voltage and current status
STATUS_TEMPERATURE	0x7D	1	command to report the device temperature status
STATUS_FANS_1_2	0x81	1	command to report the fan status
READ_EIN	0x86	6	Command to report the accumulated input power (Total power usage since AC on)
READ_VIN	0x88	2	RMS input voltage in volts(note; not used on power distribution boards) Should reset to 0 when AC is lost
READ_IIN	0x89	2	RMS input current in amps (note; not used on power distribution boards) Should report 0 when AC is lost or in standby
READ_VOUT	0x8B	2	12V Output Voltage (should reset to 0 during standby or AC is removed)
READ_IOUT	0x8C	2	12V Output Current (should reset to 0 during standby or AC is removed)
READ_TEMPERATURE1 (Ambient)	0x8D	2	Read airflow inlet temperature (should be similar to the ambient temperature)
READ_TEMPERATURE2 (hot Spot)	0x8E	2	Read hotspot temperature (should be the hottest location inside the unit)
READ_FAN_SPEED_1	0x90	2	Returns the fan speed in RPM of fan sensor 1. This data should be in linear format
READ_FAN_SPEED_2	0x91	2	Returns the fan speed in RPM of fan sensor 2. This data should be in linear format
READ_POUT	0x96	2	DC Output in Watts
READ_PIN	0x97	2	AC input power in watts (note; not used on power distribution boards). Value should reset to 0W when in standby mode or AC is lost
PMBUS_REVISION	0x98	2	Reads the revision of the PMBus to which the device is compliant

APP_PROFILE_SUPPORT	0x9F	2	Defines that the power supply supports this application profile (default profile value 04h), profile revision 1.0, (default revision value 10h)
MFR_VIN_MIN	0xA0	2	Retrieves the minimum rated value, in volts, of input voltage (ex. 90Vac). This value remains a constant value.
MFR_VIN_MAX	0xA1	2	Retrieves the maximum rated value, in volts, of input voltage (ex. 262Vac). This value is a constant value.
MFR_PIN_MAX	0xA3	2	Retrieves the maximum rated value, in watts, of input power. If there is a high line or low line input power difference, the suitable input max power should be displayed properly. (ex. Power supply with rating 1000W@100-140Vac, 1200W@180-240Vac. During 100-140Vac, MFR_PIN_MAX=(1000W+10W fan DC power)/0.88 efficiency= 1148W. During 180-240Vac, MFR_PIN_MAX=(1200W+10W fan DC power)/0.9 efficiency=1345W)
MFR_IOUT_MAX	0xA6	2	Retrieves the maximum rated 12V output current
MFR_POUT_MAX	0xA7	2	Retrieves the maximum rated value, in watts, of output power. If there is a high line or low line input power difference, the suitable input max power should be displayed properly. (ex. Power supply with rating 1000W@100-140Vac, 1200W@180-240Vac. MFR_POUT_MAX should display 1000W or 1200W according to Vac input.
MFR_TAMBIENT_MAX	0xA8	2	Retrieves the maximum rated ambient temperature, in degree C, in which the unit might be operated. This value is a constant value. (default 50 Degree C)
MFR_TAMBIENT_MIN	0xA9	2	Retrieves the minimum rated ambient temperature, in degree C, in which the unit might be operated. This value is a constant value. (Default 0 Degree C)
MFR_MAX_TEMP_1 (Ambient)	0xC0	2	Retrieves the maximum rated ambient temperature (TEMPERATURE 1), in degree C, in which the unit might be operated. This value is a constant value. (default 50 Degree C)
MFR_MAX_TEMP_2 (hot spot)	0xC1	2	Retrieves the maximum rated temperature for the hotspot (TEMPERATURE 2), in degree C, in which the unit might be operated. This value is a constant value.

CLEAR_FAULTS Command definition:

This will clear and reset all the fault and warning status bits to '0'.

CAPABILITY command definition:

Table 7. CAPABILITY COMMAND Data Byte Format

Bits	Description	Value	Meaning
7	Packet Error Checking	0	Packet Error Checking not supported
		1	Packet Error Checking is supported
6:5	Maximum Bus Speed	00	Maximum supported bus speed is 100 kHz
		01	Maximum supported bus speed is 400 kHz
		10	Reserved
		11	Reserved
4	SMBALERT#	0	The device does not have a SMBALERT# pin and does not support the SMBus Alert Response protocol
		1	The device does have a SMBALERT# pin and does support the SMBus Alert Response protocol

CAPABILITY default value:

Bits	Description	Value	Meaning
7	Packet Error Checking	1	Packet Error Checking is supported
6:5	Maximum Bus Speed	00	Maximum supported bus speed is 100 kHz
4	SMBALERT#	1	0= The device does not have a SMBALERT# pin and does not support the SMBus Alert Response protocol 1= It has SMBALERT#
3:0	Reserved	0000	reserved

QUERY Command Definition:

The QUERY command is used to ask a PMBus device if it supports a given command, and if so, what data formats it supports for that command. This command uses the Block Write-Block Read Process Call described in the SMBus specification, Version 2.0.

For the write portion of the process call, the one data byte is an unsigned binary integer, the value of which is equal to the command code requested to be investigated.

For the read portion of the process call, the one data byte is an unsigned binary integer with values as the following table.

QUERY Command Returned Data Byte Format

Bits	Value	Meaning
7	1	Command is supported
	0	Command is not supported
6	1	Command is supported for write
	0	Command is not supported for write
5	1	Command is supported for read
	0	Command is not supported for read
4:2	000	Linear Data Format used
	011	Direct Mode Format used
	101	VID Mode Format used
	110	Manufacturer specific format used
1:0	XXX	Reserved for future use

If bit [7] is zero, then the rest of the bits are “don't care”.

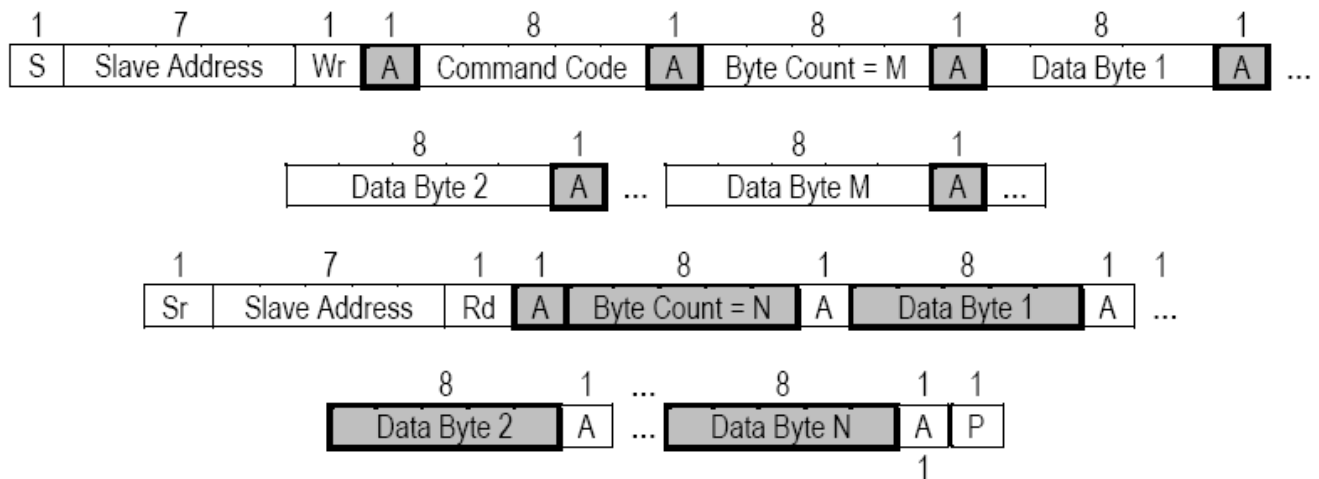

Figure 5-21: Block Write - Block Read Process Call

With PEC block write - block read:

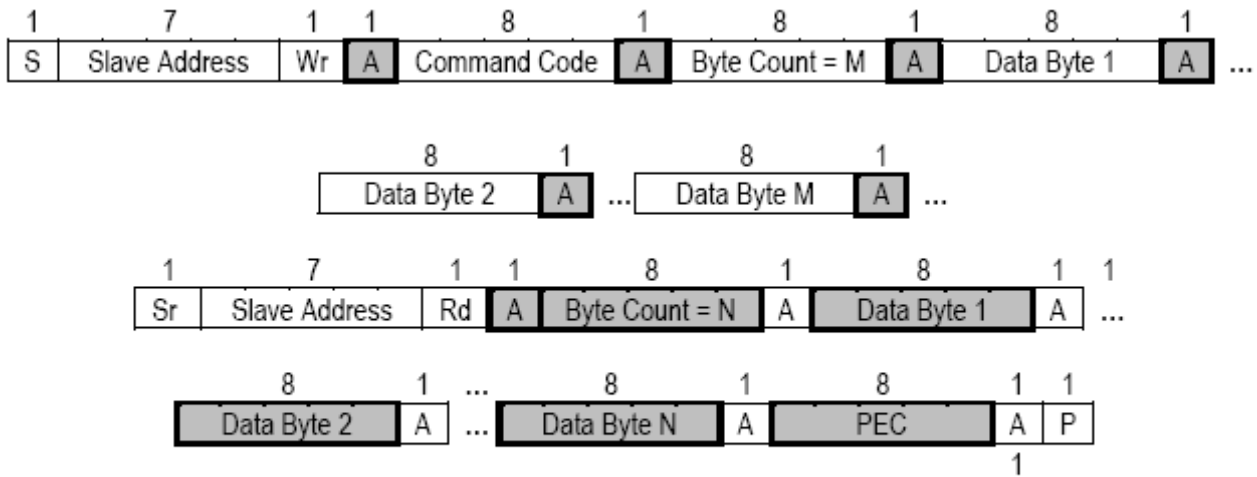

Figure 5-22: Block Write - Block Read Process Call with PEC

SMBALERT_MASK Command Definition:

The command format used to block a status bits from causing the SMBALERT# signal to be asserted. The bits in the mask byte align with the bits in the corresponding status register. For example, if the STATUS_TEMPERATURE command code were sent with mask byte 01000000b, then an Over temperature Warning condition would be blocked from asserting SMBALERT#.

STATUS_WORD and STATUS_BYTE are not used with SMBALERT_MASK and the SMBALERT_MASK. The SMBALERT_Mask for STATUS_WORD and STATUS_BYTE are not user changeable and retain the default value “1” (masked out) for all bits.

SMBALERT_MASK command can be used with any of the supported STATUS events. The events are masked from asserting SMBALERT# by writing a ‘1’ to associated STATUS bits. The SMBALERT_MASK command is used in conjunction with the PAGE_PLUS command and the STATUS_commands. Below are the protocols.

Reading mask values using PAGE_PLUS Block Write – Block Read Process Call with PEC

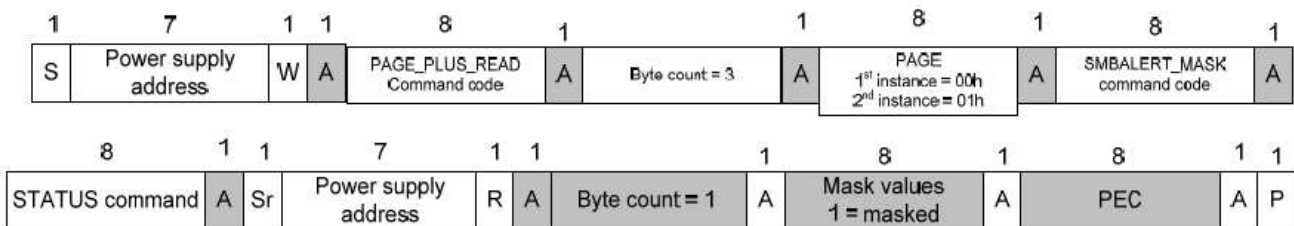
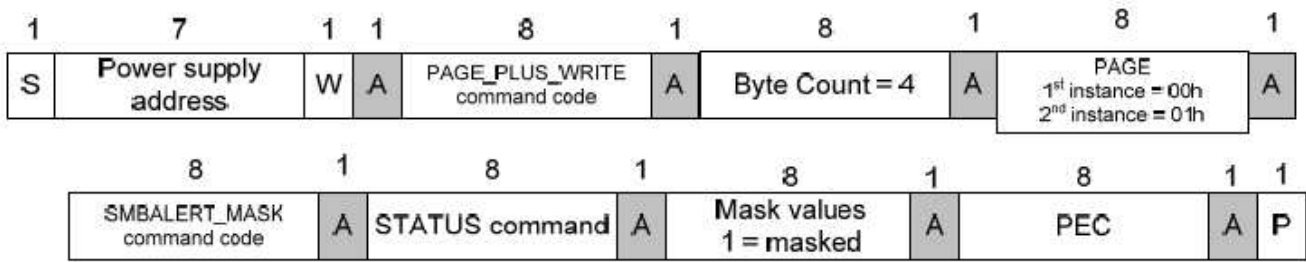

Figure 5 PAGE_PLUS_READ command.

Writing mask values using PAGE_PLUS

Block Write with PEC



STATUS_WORD is not used with SMBALERT_MASK. Only the 'root' event bits are used to control the SMBAlert signal

Figure 6 PAGE_PLUS_WRITE command.

VOUT_MODE Command Definition:

For reading output voltages the power supply shall support the VOUT_MODE command to report the output voltage formatting for the READ_VOUT command. The VOUT_MODE shall be set to Linear and the exponent (N) shall be set to -9.

VOUT_MODE settings for reading output voltage(s).

Mode	Bits [7:5]	Bits [4:0] (N)
Linear	000b	10111b (-9)

COEFFICIENT Command Definition:

The system shall use this to read the values of m, b, and R used to determine READ_EIN accumulated power values.

This command uses the Block Write-Block Read Process Call described in the SMBus specification, Version 2.0.

For the write portion of the process call, the byte count is two and there are two data bytes. The first data byte is the command of interest (ex. 0x95 for READ_EIN). The second data byte indicates whether the host requesting the coefficients needed to encode a value to be written to the device or the coefficients needed to decode a value read from the device. A value of 01h in the second data byte indicates that the coefficients needed to decode a value read from the device are being requested. A value of 00h in the second byte indicates that the coefficients needed to encode a value for writing are being requested.

For the read portion of the process call, the byte count is five and the five bytes returned are (in this order):

- 1) Lower byte of m,
- 2) Upper byte of m,
- 3) Lower byte of b
- 4) Upper byte of b,
- 5) Single byte of R.

More information on the function and application of this command are given in Section 7.2. An example of the packet construction for retrieving the coefficients from a PMBus device using PEC is shown below.

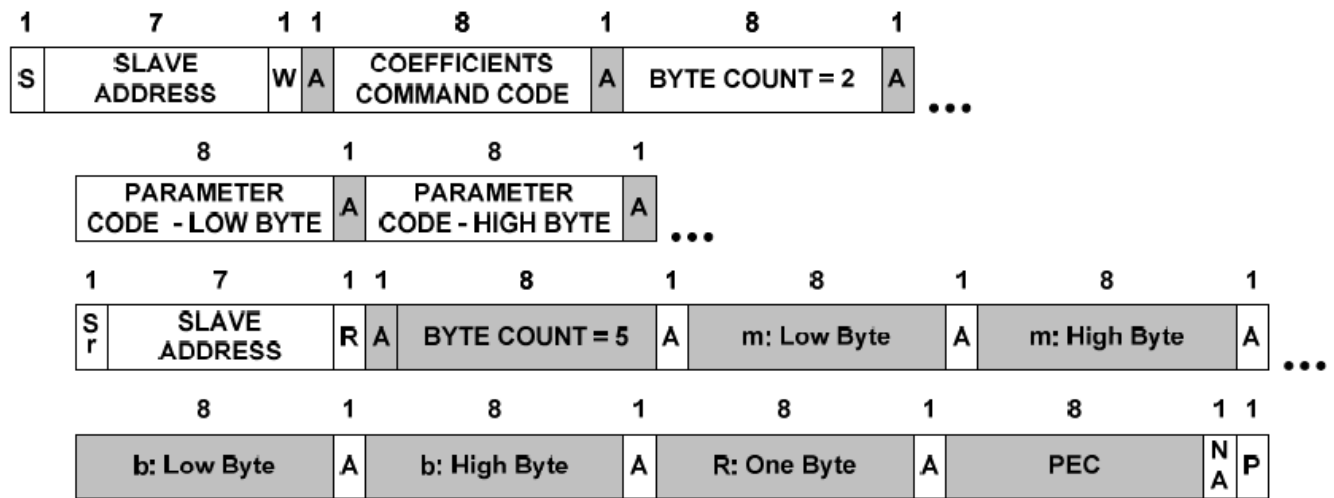

Retrieving Coefficients Using PEC

The default values of m, b, and R shall be set to:

- m=01h
- b=00h
- R=00h

FAN_CONFIG_1_2 & FAN_CONFIG_3,_4 Command Definition:

Bit(s)	Default Value	Meaning
7	1	Fan 1 presence, 0=no fan1, 1=fan1 installed
6	0	Fan 1 commanded in RPM=1, commanded in duty cycle=0; Default is 0x0=duty command
5:4	0	Not used
3	1 or 0	Fan 2 presence, 0=no fan2, 1=fan2 installed
2	0	Fan 2 commanded in RPM=1, commanded in duty cycle=0; Default is 0=duty command
1:0	0	Not used

FAN_COMMAND_1_2 Command Definition:

The system may increase the power supplies fan speed through using the FAN_COMMAND Command. This command can only increase the power supply fan speed; it cannot decrease the power supply fan speed below what the power supply commands.

The control is configured to be duty cycle controlled using the linear format of the PMBus protocol.

The exponent N is fixed to a value of 0 (N=0). The command ranges from value 0000h (0% duty) to 0064h (100% duty).

STATUS Commands:

The following PMBus STATUS commands shall be supported. All STATUS commands except the STATUS_FAN_1_2 and STATUS_BYTE commands shall be accessed with the PAGE_PLUS command since they are used by both the BMC and ME. The (BMC) and (ME) refer to the two instances of the command accessed via the PAGE_PLUS command. The status bits shall assert whenever the event driving the status bit is present. Once a bit is asserted it shall stay asserted until cleared using one of the five methods described below:

- 1) Writing a '1' to any given bit location shall reset on that bit of the command
- 2) Sending a CLEAR_FAULTS command to the power supply shall reset all STATUS_ bits to '0'
- 3) Cycling AC power OFF than ON shall reset all STATUS_ bits to '0'

- 4) Systems with redundant power supplies where only one of the supplies cycle AC power OFF/ON; the power cycled power supply shall reset the STATUS_ bits to '0' only when powered back ON. If the power supply is kept OFF, the STATUS_ bits shall not be reset.
- 5) Cycling the PSON# signal from de-asserted to asserted shall reset the STATUS_ bits to '0'. The bits shall be reset only on the assertion of PSON#; not the de-assertion.

STATUS_BYTE: Please refer to PMbus part 2 spec page 72.

		Offset 0x78	PAGES 00h=BMC 01h=ME	SMBAlert_MASK Default (0=causes assertion of SMBAlert#, 1=does not cause assertion of SMBAlert#) STATUS_Byte SMBAlert Mark is not user changeable
Bit #	7	Not used, default=0	00h, 01h	1
	6	Device is off due to PSON or for any reason (ex. Protection)=1, else 0	00h, 01h	1
	5	Output OVP fault =1, else 0	00h, 01h	1
	4	Output OCP fault =1, else 0	00h, 01h	1
	3	Vin under voltage fault =1, else 0	00h, 01h	1
	2	OTP fault =1; else 0	00h, 01h	1
	1	CML communication error=1, else 0	00h, 01h	1
	0	Other fault (A fault or warning not listed in bit [7:1] of this byte has occurred)=1, else=0	00h, 01h	1

STATUS_WORD: Please refer to PMbus part 2 spec page 74.

		STATUS_WORD, Offset 0x79	PAGES 00h=BMC 01h=ME	SMBAlert_MASK Default (0=causes assertion of SMBAlert#, 1=does not cause assertion of SMBAlert#) STATUS_Word SMBAlert Mark is not user changeable
Byte	7	Not used, default=0	00h, 01h	1
	6	Device is off due to PSON or for any reason (ex. Protection)=1, else 0	00h, 01h	1
	5	Output OVP fault =1, else 0	00h, 01h	1
	4	Output OCP fault =1, else 0	00h, 01h	1
	3	Vin under voltage fault =1, else 0	00h, 01h	1
	2	OTP fault =1; else 0	00h, 01h	1
	1	CML communication error=1, else 0	00h, 01h	1
	0	Other Fault (A fault or warning not listed in bit [7:1] of this byte has occurred)=1, else=0	00h, 01h	1
Low	7	VOUT Fault or warning =1, else 0	00h, 01h	1
	6	IOUT/POUT fault or warning =1, else 0	00h, 01h	1
	5	An input voltage, input current, or input power fault or warning =1, else 0	00h, 01h	1
	4	Not used, default=0	00h, 01h	1
	3	Power Good fault =1, else 0	00h, 01h	1
	2	Fan fault or warning =1, else 0	00h, 01h	1
	1	Not used, default=0	00h, 01h	1
High				

STATUS_IOUT Command Definition:

Bit	STATUS_IOUT, Offset 0x7B	PAGEs 00h=BMC 01h=ME	SMBAlert_MASK Default (0=causes assertion of SMBAlert#, 1=does not cause assertion of SMBAlert#)
7	IOUT Overcurrent Fault	00h, 01h	1
6	Not used, default=0	00h, 01h	1
5	IOUT Overcurrent Warning (>90% of rated output current)	00h, 01h	1
4	Not used, default=0	00h, 01h	1
3	Not used, default=0	00h, 01h	1
2	Not used, default=0	00h, 01h	1
1	POUT Overpower Fault	00h, 01h	1
0	POUT Overpower Warning (>90% of output power)	00h, 01h	1

STATUS_INPUT Command Definition:

Bit	STATUS_INPUT, Offset 0x7C	PAGEs 00h=BMC 01h=ME	SMBAlert_MASK Default (0=causes assertion of SMBAlert#, 1=does not cause assertion of SMBAlert#)
7	VIN Over voltage Fault	00h, 01h	1
6	VIN Over voltage Warning (Vin>240Vac)	00h, 01h	1
5	Vin Under voltage Warning (Vin<90Vac)	00h, 01h	Page 00h=1; Page 01h=0
4	Vin Under voltage Fault	00h, 01h	1

3	Unit is off for insufficient Input Voltage (Input UVP)	00h, 01h	1
2	IIN Over current Fault	00h, 01h	1
1	IIN Over current Warning (when IIN over rated input current)	00h, 01h	1
0	Not used, default=0;	00h, 01h	1

STATUS_TEMPERATURE Command Definition:

Bit	STATUS_TEMPERATURE, Offset 0x7D	PAGEs 00h=BMC 01h=ME	SMBAlert_MASK Default (0=causes assertion of SMBAlert#, 1=does not cause assertion of SMBAlert#)
7	Overtemperature Fault	00h, 01h	1
6	Overtemperature Warning	00h, 01h	Page 00h=1; Page 01h=0
5	Undertemperature Fault	00h, 01h	1
4	Undertemperature Warning	00h, 01h	1
3	Not used, default=0;	00h, 01h	1
2	Not used, default=0;	00h, 01h	1
1	Not used, default=0;	00h, 01h	1
0	Not used, default=0;	00h, 01h	1

STATUS_FANS_1_2 Command Definition:

Bit	STATUS_FANS_1_2, Offset 0x81	PAGEs 00h=BMC 01h=ME	SMBAlert_MASK Default (0=causes assertion of SMBAlert#, 1=deso not cause assertion of SMBAlert#)
7	Fan 1 Fault=1, else=0	N/A	1
6	Fan 2 Fault=1, else=0	N/A	1
5	Not used, default=0;	N/A	1
4	Not used, default=0;	N/A	1

3	Fan 1 Speed Overridden (When User command is applied)=1; else 0	N/A	1
2	Fan 2 Speed Overridden (When User command is applied)=1; else 0	N/A	1
1	Not used, default=0;	N/A	1
0	Not used, default=0;	N/A	1

READ_EIN Command Definition:

The READ_EIN command shall use the PMBus direct format to report the accumulated power value and the sample count. The PMbus coefficients m, R, and B shall be fixed values and the power supply shall report these values using the PMBus COEFFICIENT command. The coefficient m shall be set to 01h, coefficient R shall be set to 00h, and coefficient b shall be set to 00h.

READ_EIN Requirements Summary

	MIN	MAX	Description
Format	PMBus Direct format m = 01h, R = 00h, b = 00h		PMBus data format; refer to PMBus specification for details.
P _{sample} averaging period	= 4 AC cycles		Period instantaneous AC power is averaged over to calculate P _{sample} .
[P _{accum} / N] Accuracy (10% to 19% load)	+/-15%		The calculated input power data shall meet these accuracy requirements over 100-240VAC and under the defined system polling rate.
[P _{accum} / N] Accuracy (20% to 100% load)	+/-5%		
System polling rate	1 sample / sec	10 samples / sec	The power supply shall be polled over this range of rates while testing accuracy.

READ_EIN shall use the SMBus block Read with PEC protocol in the below format:

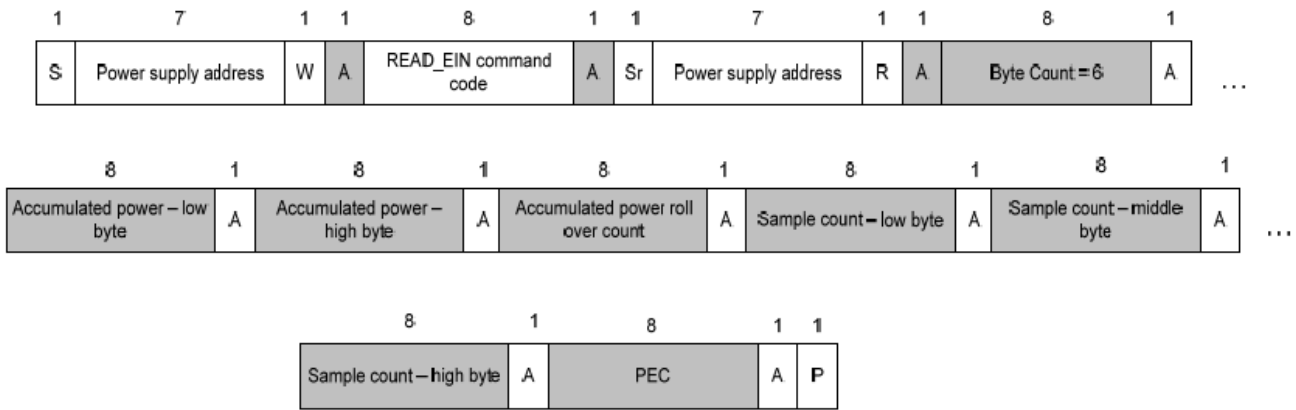

READ_EIN Command

READ_EIN Accumulators:

The accumulated power data shall be the sum of input power values averaged over 4 AC cycles. The value shall automatically roll-over when the 15bit maximum value is reached (>7FFFh). The sample count should increment 1 for each accumulated power value. The system shall calculate average power by dividing the accumulated power value by the sample count. The system must sample READ_EIN faster than the roll-over period to get an accurate power calculation. If the system sees a smaller value than the previous sampled data; then the system must account for the roll-over by adding 7FFFh to the present value. Below is a block diagram depicting the READ_EIN accumulator function in the power supply.

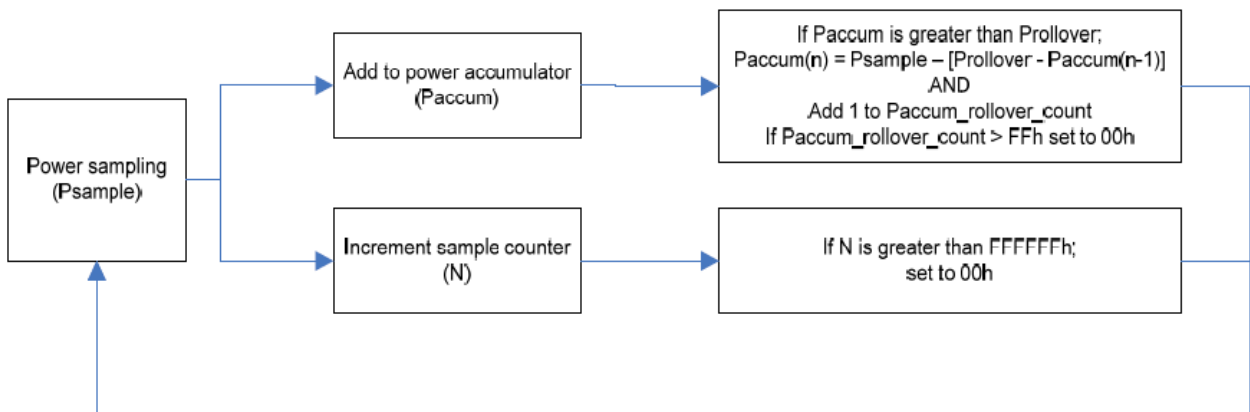

Psample: The sampled power value in linear or direct format

Paccum: 2 bytes in PMBus linear or direct format.

The accumulated power values made up of Psample(0) + Psample(1) + ... + Psample(n)

N: 3 byte unsigned integer value. The number of accumulated power values summed in Paccum

Prollover: The max value of Paccum before a rollover will occur

Paccum_rollover_count: 1 byte unsigned integer counting the number of times Paccum rolls over.

Once this reaches FFh; it will automatically get reset to 00h

READ_EIN Power Supply Functional Diagram

Resetting READ_EIN

The READ_EIN power accumulator, roll-over counter, and sample count should keep the latest value when the power supply is put into standby mode. The power accumulator, roll-over counter and sample count should reset to 00 when AC power is lost.

PMBUS_REVISION Value:

Bits 7:4	Part I Revision	Bits 3:0	Part II Revision
0010	1.2	0010	1.2

6.2.F Manufacturer Specific Commands:

Offset 0xD0-0xDE is used to represent the unit model serial number. Data represented in byte format.

These bytes are read/write capable through I2C

Below serial number is for example only:

PWS-501P-1R

Offset	Serial number	
	character	Hex
D0	P	50
D1	5	35
D2	0	30
D3	5	35
D4	P	50
D5	C	43
D6	B	42
D7	0	30
D8	1	31
D9	A	41
DA	0	30
DB	0	30
DC	0	30
DD	0	30
DE	1	31

Offset 0xE0 – 0xEB is used to represent the model number, data represented in byte format.

These bytes are read/write capable through I2C.

PWS-741P-1R

Offset	Item number	
	character	Hex
E0	P	50
E1	W	57
E2	S	53
E3	-	2D
E4	5	35
E5	0	30
E6	1	31
E7	P	50
E8	-	2D
E9	1	31
EA	R	52

Additional information bytes for FRU backward compatibility. These bytes are read/write capable.

Offset	Function	Description
ED	Temperature upper limit	Internal temperature upper limit in degree Celsius. Direct data format, data length is one byte.
EE	Fan 1 pulse count lower limit	Value to represent the lower limit RPM of the power supply fan #1 The system software will convert this value, to fan RPM, using: RPM limit=(1/0.262) *(Fan Pulse Count limit * 60 /2)
EF	Fan 2 pulse count lower limit	Same calculation as fan 1. If fan 2 is not available, default value is 0x00.

Offset 0xF0-0xF5 is used to represent the unit revision number. Revision begins with Rev 1.0. Data is represented in byte format. These bytes are read/write capable using I2C.

Offset	Revision	
	character	Hex
F0	R	52
F1	E	45
F2	V	56
F3	1	31
F4	.	2E
F5	0	30

6.2.G Sensor Sampling

The sensor registers inside the power supply for monitoring input/output power, current, and voltage shall meet the following minimum requirements. Register refresh rate is the frequency the sensor register gets updated with a new measurement value.

Register refresh rate \geq 10Hz

6.2.H Sensor Averaging

The sensor registers for monitoring input/output power, current, and voltage shall contained averaged data, not instantaneous peak data. This may be achieved in two ways; an arithmetic average or a low pass filter. An exponential moving average shall not be used. The power supply shall refresh the sensor data at a rate no slower than the averaging duration.

READ_PIN, shall be an average value over a 2 second interval.

READ_IIN and READ_VIN shall be an RMS value over a 2 second interval.

6.2.I Accuracy

The sensor commands shall meet the following accuracy requirements.

	10% of max load	20% of max load	50% of max load	100% of max load
READ_IIN	READ_IIN accuracy must be able to meet READ_PIN requirement below	+/-2%	+/-2%	+/-2%
READ_PIN	+/-5% or +/- 10W	+/-5%	+/-5%	+/-5%
READ_IOUT	+/-4%	+/-3%	+/-3%	+/-3%
READ_POOUT	+/-5% or +/- 10W	+/-5%	+/-5%	+/-5%
READ_VIN	+/- 2% over full range			
READ_VOUT	+/- 2% over full range			
READ_TEMPERATURE	Required: +/-2 °C			

6.2.J Linearity

For any increase in actual power or current the resulting PMBus reading shall stay the same or increase. For any decrease in actual power or current the resulting PMBus reading shall stay the same or decrease.

6.2.K Resolution

The resolution of the PMBus input power sensor shall be no more than 3W. With an increasing or decreasing load in 1W steps; the associated power change using READ_PIN shall not exceed 3W.

6.3 SMBAlert

The SMBAlert# Signal may be asserted (pulled low, less than 0.4V) by the power supply for any of the supported STATUS events. The events that control SMBAlert# can be masked during the SMBALERT_MASK command. Default masking is shown in section 4.4.2.E of the status command definitions.

By default the SMBAlert# signal is asserted for the following cases:

- 1) AC Input voltage drops below the fault threshold (<90Vac) for more than 2ms.
- 2) Thermal sensor on a hot spot inside the power supply has exceeded its warning temperature (OTP temperature minus 3 degree C) for over 1sec.
- 3) Power supply is turned off due to PSON
- 4) Power Supply Fan fail
- 5) Power supply failure

The power supply does not support Alert Response Address (ARA). After asserting the SMBAlert# signal, the power supply shall keep its address at its standard address; not change to 18h.

The SMBAlert# signal shall be asserted whenever any un-masked event has occurred. This is a level detected event. Whenever the event is present SMBAlert# shall be asserted. If the SMBAlert signal is cleared, it shall immediately re-asserted if the event is still present.

The SMBAlert# signal shall be cleared and re-armed by the following methods:

- 1) Clearing STATUS bits causing the asserted SMBAlert# signal.
- 2) Power cycling with PSON or with AC power

During Standby mode or AC off, SMBAlert# should be logic low (less than 0.4V) and be able to sink 4mA current.

SMBAlert Logic Level

	MIN	MAX
Logic level low voltage, Isink = 4mA	0V	0.4V
Logic level high voltage, Isource = 200 μ A	2.4V	5.25V

6.4 Faults and Error Checking

The power supply shall support PEC(packet error checking) per the SMBus 2.0 specification.

7 Protection Circuits

Protection circuits inside the power supply shall cause only the power supply's main outputs to shutdown. If the power supply latches off due to a protection circuit tripping, an AC cycle OFF for 10 seconds and a PSON cycle HIGH for 1 second shall be able to reset the power supply.

7.1 Over Current Protection

The power supply shall have current limit to prevent +12 V outputs from exceeding the values shown in Table 5. If the current limits are exceeded (duration must keeping 200mS), the power supply shall shutdown (after 200mS later) and latch off with no damage occur to PDB self and power supply. The latch will be cleared by toggling the PSON signal or by an AC power interruption. The power supply shall not be damaged from repeated power cycling in this condition. 5 VSB shall be protected (auto-recovering mode) under over current or shorted conditions so that no damage can occur to the power supply . All outputs shall be protected so that no damage occurs to the power supply under a shorted output condition.

Table 5: Over Current Protection

Voltage	Over Current Limit (Iout limit)
+12 V	110% minimum; 130% maximum
+5Vsb	110% minimum;130% maximum

7.2 240VA Protection

Not applicable

7.3 Over Voltage Protection

The power supply over voltage protection shall be locally sensed. The power supply shall shutdown and latch off after an over voltage condition occurs. This latch shall be cleared by toggling the PSON signal or by an AC power interruption. Table 6 contains the over voltage limits. The values are measured at the output of the power supply's connectors. The voltage shall never exceed the maximum levels when measured at the power pins of the power supply connector during any single point of fail. The voltage shall never trip any lower than the minimum levels when measured at the power pins of the power supply connector.

Table 6: Over Voltage Limits

Output Voltage	MIN (V)	MAX (V) & mode
+12 V	13.3	14.5 latch-off
+5 VSB	5.7	6.5 latch-off

7.4 Over Thermal Protection

The power supply over thermal protection shall be locally sensed. The power supply shall shutdown and latch off after an over required temperature condition occurs. This latch shall be cleared by toggling the PSON signal or by an AC power interruption. The over thermal limits that power supply which components contain required maximum temperature. The temperature shall never exceed the maximum levels when measured at the individual component.

7.5 Short Circuit Protection

All outputs shall be protected and into latch off mode so that no damage occurs to the power supply under a shorted output condition. This latch shall be cleared by toggling the PSON signal or by an AC power interruption. 5Vsb should be protected and into hiccup mode. No damage occurs to the power supply under a shorted output condition, and should be output normally after shorted output released.

8 Environmental Requirements

8.1 Temperature

8.1.1 Normal Operating Ambient (at sea level):

0 degrees Celsius minimum (operating and in standby)

50 degrees Celsius maximum (operating – power supply on)

maximum rate of change is 30 degrees Celsius/hour

8.1.2 Abnormal Operating Ambient(at sea level):

N/A degrees Celsius N/A
survival time

8.2 Humidity

Operating : 20% to 95% RH Storage : 5%
to 95% RH

8.3 Altitude

Operating: to 10,000 feet (3,023 meters) Non-operating:

to 35,000 feet (10,580 meters)

8.4 SHOCK AND VIBRATION

8.4.1 Mechanical Shock

The device will withstand the following imposed conditions without electrical or mechanical failure: Non-operating Square Wave Shock: 40G, Square wave at 200in/sec (508cm/sec); on all six sides Non-operating Half Sine Shock: Half Sine pulse for 70in/sec (178cm/sec) for 2ms; on all sides except top Operating Half Sine Shock: Half Sine pulse for 40in/sec (102cm/sec) for 2ms; on all sides except top

8.4.2 Vibration

Operating: Sinusoidal vibration, 0.5G (0-peak) acceleration. 3-500Hz, sweep at 1/2 octave/min from low to high frequency, and then from high to low. Thirty minute dwell at all resonant points, where resonance is defined as those exciting frequencies at which the device under test experiences excursions two times larger than non-resonant excursions.

Plane of vibration to be along three mutually perpendicular axis.

Non-operating: Sinusoidal vibration, 1.0G (0-peak) acceleration. 3-500Hz, sweep at 1/2 octave/min from low to high frequency, and then from high to low. Thirty minute dwell at all resonant points, where resonance is defined as those exciting frequencies at which the device under test experiences excursions two times larger than non-resonant excursions.

8.4.3 THERMAL SHOCK

Non-operating: -40 (+/-5) to +70 (+/-5) degrees Celsius, transition time not to exceed 5 minutes. Duration of exposure to temperature extremes will be 20 minutes.

8.5 MTBF and Quality Data

8.5.1 MTBF

The life requirement shall be met the following condition. And the environmental temperature is assumed to be 25 degrees Celsius. Normal operation (at the rated input/output): 200,000h.

9 Regulatory Agency Requirements

The power supply must comply with all regulatory requirements for its intended geographical market as computer server of Information Technology Equipment.

The power supply must meet all regulatory requirements for the intended market at the time of manufacturing. This power supply shall have below certificates for ITE category:

- UL
- C-UL
- TUV
- BSMI
- CCC
- CB
- CISPR Class A
- FCC Class A
- CE criteria B for power supply itself
- RoHS (Full ROHS lead free 6/6)
- Efficiency 80plus platinum Single Output
- Immunity to meet ITE machine category on EN61000-4-X

The power supply itself meets class A with 6 dB margin of EMI limits for CE, FCC, CISPR tested with min-max full output resistance load, and certificated with CE compliance.

The power supply, when installed in the system, shall meet immunity requirements specified in EN55024.

Specific tests are to be EN61000-4-2, -3, -4, -5, -6, -8, and -11. The power supply must maintain normal performance within specified limits. Conformance must be designated with the European Union CE Marking.

Specific immunity level requirements are left to customer requirements. [Criteria A of EMC immunity regulatory.](#)

10 Control acoustic noise and Fan Speed Control

Acoustic noise limitation: The acoustic noise level of PS stand-alone operation including stand-by operation must be less than 15dBA without fan and 28dBA at max load. The vendors need to provide the test data of acoustic noise without fan for during DVT, PR stages.

When AC plug in, Fans will be on and have minimum speed to cooling power supply to keep normal

operating temperature. The power supply will have internally controlled PWM fans. The PWM fans will be thermal controlled by microcontroller. Note that speed transition should be non-linear to reduce perceived noise from fan.

Fan control speed rule is shown in the attached file (refer to 1400W PS) below.



PWM Fan Control
Design Guideline 0.1.

Fan Speed Control

The power supply will have an internally controlled 28mm fan. The fan will be 4 wires PWM Fan controlled by internal temperature and will have a slope of TBD.

11 Output Connector and Dimension

The power supply will provide a card edge connector compatible with the backplane. See power supply mechanical drawing for dimensions. The power supply connector is a 6 blade (3 pair) and 20 pins (10 pair) edge connection type from Tyco Electronics, Mfr P/N 1489958-1 or FCI P/N 10034908 connector.

Power and Signal Connection

Description	Pin Number	I/O	Active	Pin Length
Ishare	1		Analog	Standard
A1 (address)	2	I/O	High/Low	Standard
A0 (address)	3	I/O	High/Low	Standard
I2C SCL	4	I/O	High/Low	Standard
I2C SDA	5	I/O	High/Low	Standard
PS ON/OFF	6	I	Low	Short (by 1mm)
SMBAAlert	7			
DC GOOD	8	O	High	Standard
+12V	9		Power Pin	Standard
+12V	10		Power Pin	Standard
+12V	11		Power Pin	Standard
+12V	12		Power Pin	Standard
+12V	13		Power Pin	Standard
RS GND	14		Analog	Standard
Spare	15			
12V RS GND	16		Analog	Standard
Fan Control	17	I	High	Standard
DC Return	18		Power Pin	Standard
5Vsb CO	19		Power Pin	Standard
5Vsb CO	20		Power Pin	Standard
DC Return	21		Power Pin	Standard
DC Return	22		Power Pin	Standard
DC Return	23		Power Pin	Standard
DC Return	24		Power Pin	Standard
DC Return	25		Power Pin	Standard
DC Return	26		Power Pin	Standard

Note: The signal pins on the power supply connector will be gold plated to 30 micron inch.

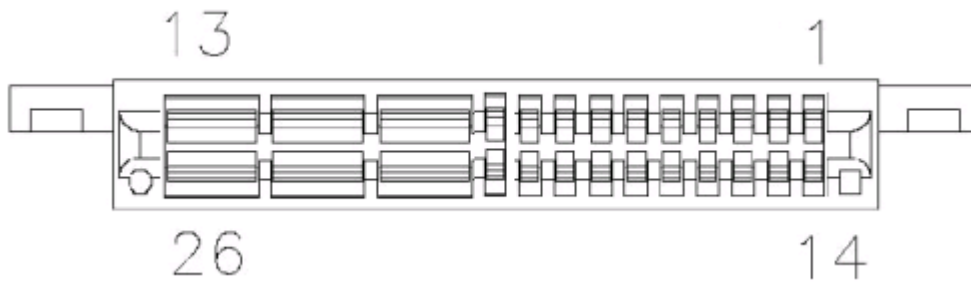

The power dimension is same current PWS-801-1R



PWS8011R.pdf

Barcode:

501P-1R..... P505PCYWWRMSSSS.

12 Assembly Process

Supermicro confirms the assembly process, test process. If they have a problem, Supermicro requests to improve the problem.

13 Safety

13.1 Dielectric Strength Testing (Hi-pot)

All units must pass a 1500VAC line to ground/chassis hi-pot test. The voltage must be maintained at that level for a minimum of 1 second without failure.

13.2 Ground Continuity Testing

All units must pass a ground continuity test with less 0.1 Ohm from the ground (third wire) input pin to the chassis.

- NOTES:
1. INTERPRET DIMENSIONS PER CNS.
 2. DIMENSIONS NOT SHOWN ON DRAWING SHALL REFER TO A GENERAL TOLERANCE.
 3. ALL EXPOSED EDGES MUST BE HANDLED AS SHOWN IN THE DRAWING. ALL SHARP EDGES MUST BE SPECIFIED IN THE DRAWING.
 4. METAL SURFACE AND THE FINISH SURFACE PROCESS SHALL BE FULLY INSPECTED.
 5. ALL COMPONENTS AND THEIR MANUFACTURING PROCESS SHALL BE FULLY INSPECTED.
 6. DIMENSIONS WITH SYMBOL M ARE CRITICAL, MUST BE INSPECTED EVERY SHIPMENT.

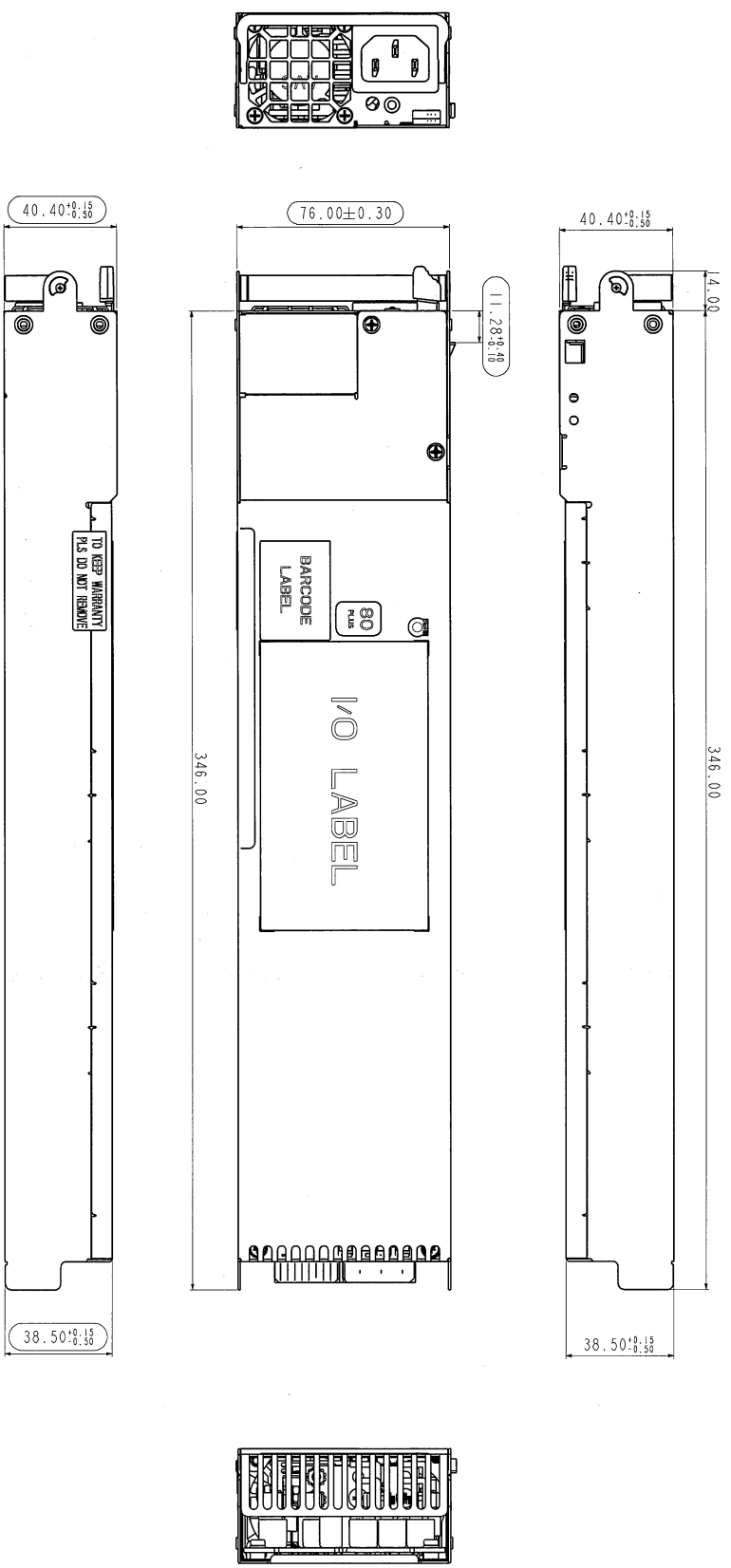

REV.	Description	Modify By	Modify Date	Amendment No.	ECR No.
Δ	Release	Jones	2011-09-22	-	-
Δ	-	-	-	-	-
Δ	-	-	-	-	-

COMPUWARE		COMPUWARE TECHNOLOGY CO., LTD.	
Model:	CPR-5011-3M(LPMS-501P-1R)	Drawing No.:	CPR-5011-3M(LV1.0)
Title:	OUTLINE DRAWING	Part No.:	CPR-5011-3M(LV1.0)
CTO	Approved	Reviewed	Drawing
	<i>Serry</i>	<i>Wark</i>	<i>Swartz</i>
Material	Finish	Unit	Scale
		mm	1:1.5
Version	Revision	Scale	Version
30-500 ± 0.20	10-500 ± 0.20	1:1.5	10-500 ± 0.20
Angle	± 1.00°		

Compuware copy right, do not copy without legal permission.