

1 Scopes and Definition

This specification defines the performance characteristics of a single-phase (3-wire) 1.2KW single output power supply with wide range input AC capability (100-240VAC/50-60Hz) under operation temperature 50 degree C. The power supply shall be designed for parallel operation. In the event of a power supply failure, the redundant power supply continues to power the system even under over voltage fault. The number of power supplies per system will be limited to a maximum of three. The power supply shall be designed for "hot swap" exchange and must contain the OR-ing isolation MOSFETs for all outputs and shall communicate to external devices through Inter-Integrated (I2C) Circuit protocol. The power supply will have an EEPROM for storing powers supply FRU information, and meet PMBus™ Revision 0.3 requirement.

2 Input Requirement

2.1 AC Input Requirements

The Power supply must be have a universal power input with active power correction to reduce the line harmonics in accordance with the EN61000-3-2 standard, see section 9 for detailed regulatory standards.

The power supply must be capable of operating with the following Conditions

	Minimum	Nominal	Maximum	Unit
Input Voltage Range(Vac)	85	100~240	264	Vac
Input Frequency(Hz)	47	50~60	63	Hertz
Input Current(A)	13	12-5	4	Amperes

The unit must not go into hiccup mode when in the boundary of Turn on voltage threshold, an ACUV circuit is recommended.

2.2 Power Factor

The power supply must have a minimum 0.98 at 115Vac and minimum 0.96 at 240Vac measured with 40% and 80% load.

2.3 Inrush Current

When input power is applied to the power supply any initial current surge or spike of 10ms or less will not exceed 25A peak. Any additional inrush current surges or spikes in the form of AC cycles or multiple AC cycles greater than 10ms, and less than 150ms, must not exceed 15A peak. After 150ms the AC input current must meet the input AC current requirements 2.1

For any conditions during turn-on the inrush current will not open the primary input fuse or damage any other components.

2.4 Efficiency

The Power supply must have a minimum of 85% Efficiency measured at 20% output loading with nominal input AC voltage condition. It shall have minimum 92% peak efficiency for 230Vac input without fan power.

Also efficiency should be meet climate saver targets level as below (AC input 230Vac only).

Load (without fan power)	Efficiency	Power factor
20%	88	0.9
50%	92	0.96
100%	88	0.98

Or

80 PLUS Gold Single Output Redundant PFC .90 at 50%		
Percent Loading	Efficiency	
20%	88%	
50%	92%	
100%	88%	

2.5 Input fuse

The Input fuse must be slow blow or normal blow high breaking type.

2.6 Input Receptacle

The AC input receptacle must be approved by Product Safety Regulatory Agencies and must be rated properly for current, voltage and temperature. The AC input connector shall be an IEC 320 C-14 power inlet.

2.7 Input Under Voltage

The power supply shall contain protection circuitry such that application of an input voltage below the minimum specified in section 2.1 shall not cause damage to the power supply. Input voltage range for AC minimum startup voltage, 82-89VAC, and maximum turn off voltage range 73 to 83VAC.

2.8 AC Line Transient Specification

AC line transient conditions shall be defined as “sag” and “surge” conditions. Sag conditions (also referred to as “brownout” conditions) will be defined as the AC line voltage dropping below nominal voltage. Surge will be defined as the AC line voltage rising above nominal voltage.

The power supply shall meet the requirements under the following AC line sag and surge conditions.

Table 1: AC Line Sag Transient Performance

Duration	Sag	Operating AC Voltage	Line Frequency	Performance Criteria
Continuous	10%	Nominal AC Voltage ranges	50/60 Hz	No loss of function or performance
0 to 1 AC cycle	100%	Nominal AC Voltage ranges	50/60 Hz	No loss of function or performance
> 1 AC cycle	>10%	Nominal AC Voltage ranges	50/60 Hz	Loss of function acceptable, self-recoverable

Table 2: AC Line Surge Transient Performance

Duration	Surge	Operating AC Voltage	Line Frequency	Performance Criteria
Continuous	10%	Nominal AC Voltages	50/60 Hz	No loss of function or performance
0 to ½ AC cycle	30%	Mid-point of nominal AC Voltages	50/60 Hz	No loss of function or performance

2.9 AC Line Fast Transient Specification

The power supply shall meet the EN61000-4-5 directive and any additional requirements in IEC1000-4-5:1995 and the Level 3 requirements for surge-withstand capability, with the following conditions and exceptions:

- These input transients must not cause any out-of-regulation conditions, such as overshoot and undershoot, nor must it cause any nuisance trips of any of the power supply protection circuits.
- The surge-withstand test must not produce damage to the power supply.
- The supply must meet surge-withstand test conditions under maximum and minimum output load conditions.
-

3 Output Requirements

3.1 Output regulation Requirements

All outputs must maintain their regulation with the below limits when measured at the output connector point or across the remote sense (if applicable) in any load condition defined in **section 3.2**

Output	Minimum	Nominal	Maximum	Unit
+12V	11.4	12.0	12.6	Vdc
+5Vsb	4.80	5.0	5.25	Vdc

3.2 Output Current Requirements

All outputs must maintain their regulation as per **section 3.1** when loaded to the following loading combination:

Output	Minimum	Maximum	Unit	Input VAC
+12V	0.5	100	Adc	180 to 264
+12V	0.5	83	Adc	90 to 140
+5Vsb	0	4.0 / 6.0 max	Adc	90 to 264

Note: +5Vsb will be designed to meet 6A load and will be tested with 6A load at production line. Model label Will Print 4A rating only.

The total output power can not exceed **1005W** continuously for 90 to 140VAC input, and **1205W** continuously for 180 to 264 VAC input. During load changes from minimum to maximum or maximum to minimum the unit must not shut down.

3.3 Output Ripple and Noise

The following output ripple/noise requirements will be met throughout the load ranges specified in **section 3.2** and under all input voltage conditions specified in **section 2.1**.

Ripple and noise are defined as periodic or random signals over the frequency band of 10Hz to 20MHz.

Measurements will be made with an oscilloscope set to 20MHz bandwidth limit. Measurement is done by using 10uF Tantalum in parallel with a 0.1uf ceramic capacitor, measured directly at the output connector side (Note: care must be taken when doing measurements such as using the smallest grounding wire.).

Output	Maximum	Unit
+12V	120	mV
+5Vsb	50	mV

3.4 Output Dynamic Loading

The output voltages shall remain within the limits specified in **section 3.1** for the step loading and within the limits specified in **section 3.5** for the capacitive loading. The load transient repetition rate shall be tested between 50 Hz and 5 kHz at duty cycles ranging from 10%-90%. The load transient repetition rate is only a test specification. The Δ step load may occur anywhere within the MIN load to the MAX load shown in **section 3.2**

3.4 Transient Load Requirements

Output	Δ Step Load Size	Load Slew Rate	Capacitive Load
12V	65% of max load	0.5 A/ μ s	2200 μ F
+5 VSB	25% of max load	0.5 A/ μ s	1 μ F

3.5 Capacitive Loading

The power supply shall be stable and meet all requirements, except dynamic loading requirements, with the following capacitive loading ranges.

3.5 Capacitive Loading Conditions

Output	MIN	MAX	Units
+12 V	10	11,000	μ F
+5 VSB	1	350	μ F

4 Redundancy Requirements

4.1 Current Sharing Operation

The power supply shall be designed for active current sharing.

Two or more than two power supplies will be paralleled in a system. Each power supply must be able to share load to within 10% share error measured 25, 50, 100% of single power supply full load current.

5Vsb requires an "ORing" diode or FET to provide protection against internal short circuit fault.

4.2 Output Isolation Oring MOSFET

The 12V output current must pass through an Oring MOSFET to protect the bus voltage against a power supply internal fault.

4.3 Power Supply Behavior When Faulted

1. The faulted supply shall not sink more than 100 mA current.
2. I2C bus status shall be operational and valid, refer to "I2C Bus/VPD Interface".
3. The "DC Good" signal and "DC Good Fault" bit status shall be valid.
4. A power supply that fails due to a 12V or 5Vsb Over-Voltage condition will shutdown gracefully and will not cause shutdown of the other power supplies in parallel.

4.4 Parallel Stability

The power supply shall be unconditionally stable under all system load and AC line conditions while operating alone or in parallel mode.

4.5 Hot Swap

The power supply must be designed with "hot swap" function with or without active AC line cord. After Hot swap I2C address shall be same as host power supply backplane hardware assigned. Host existing working power supply shall not be affected by hot swapping power supply.

5 Controls and Signal

5.1 Timing Requirements

These are the timing requirements for the power supply operation. The output voltages must rise from 10% to within regulation limits ($T_{\text{vout_rise}}$) within 5 to 20 ms.

Each output voltage shall reach regulation within 20 ms ($T_{\text{vout_on}}$) of each other during turn on of the power supply. Each output voltage shall fall out of regulation within 400 ms ($T_{\text{vout_off}}$) of each other during turn off. Figure 1 and Figure 2 the turn ON and turn OFF timing requirements. In Figure 2, the timing is shown with both AC and PSON# controlling the ON/OFF of the power supply.

Item	Description	MIN	MAX	Units
$T_{\text{vout_rise}}$	Output voltage rise time from each main output.	5	20	ms
$T_{\text{vout_on}}$	All main outputs must be within regulation of each other within this time.		20	ms
$T_{\text{vout_off}}$	All main outputs must leave regulation within this time.		400	ms

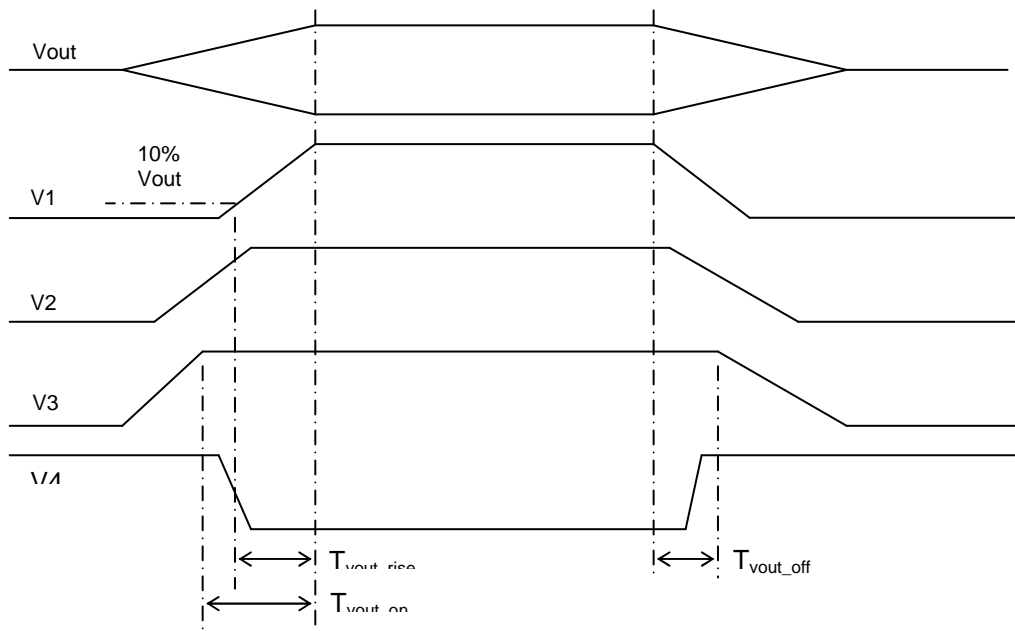

Fig. 1 Output Voltage Timings

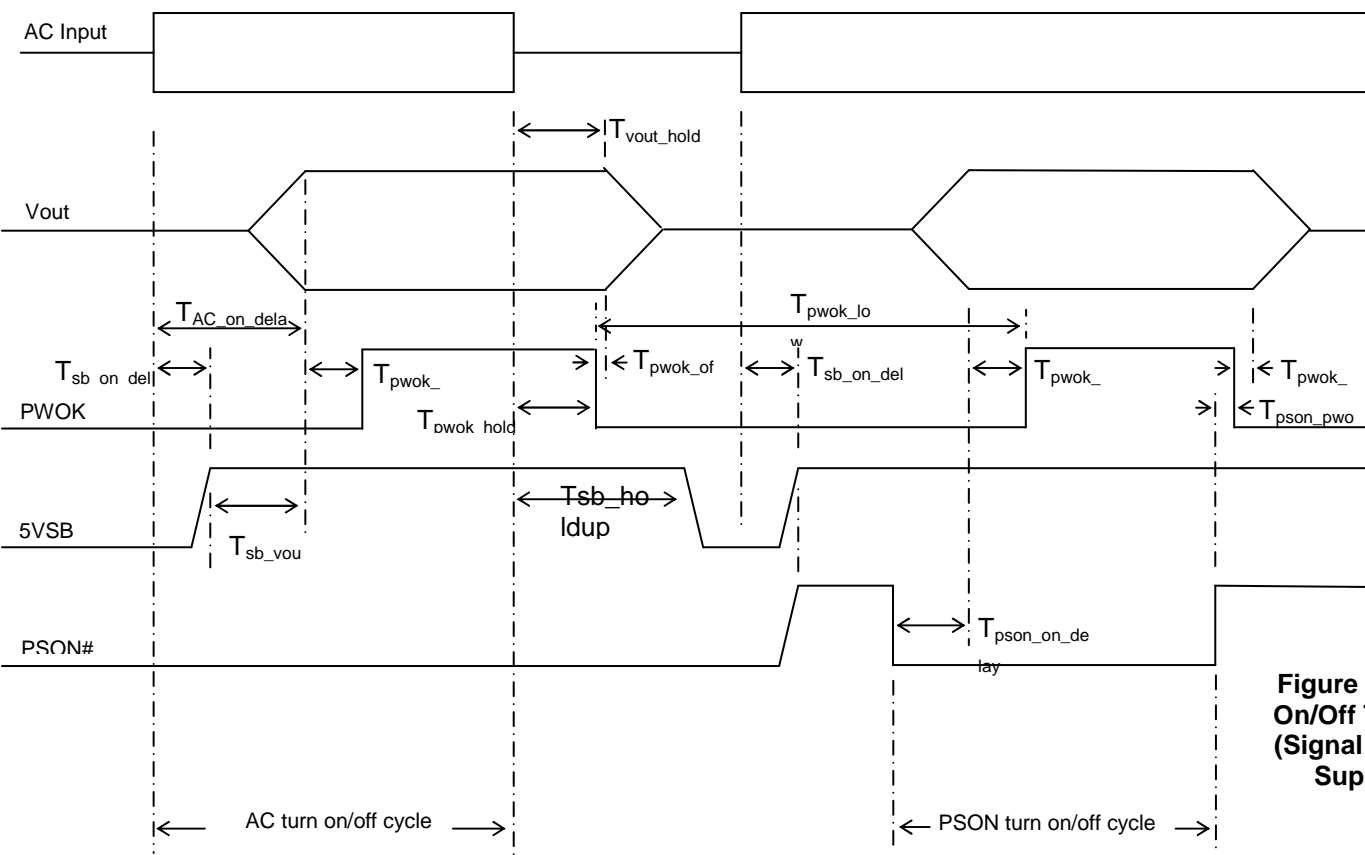

Figure 2 Turn On/Off Timing (Signal Power Supply)

Item	Description	MIN	MAX	Units
Tsb_on_delay	Delay from AC being applied to 5 VSB being within regulation.		1500	ms
T ac_on_delay	Delay from AC being applied to all output voltages being within regulation.		2500	ms
Tvout_holdup	Time all output voltages stay within regulation after loss of AC at 75% load	17		ms
Tdc_good_hold up	Delay from loss of AC to deassertion of DC Good	16		ms
Tpsn_on_delay	Delay from PSON# active to output voltages within regulation limits.	5	400	ms
Tpsn_dc_good	Delay from PSON# deactive to DC Good being deasserted.		50	ms
Tdc_good_on	Delay from output voltages within regulation limits to DC Good asserted at turn on.	50	120	ms
Tdc_good_off	Delay from DC Good deasserted to output voltages dropping out of regulation limits.	1		ms
Tdc_good_low	Duration of DC Good being in the deasserted state during an off/on cycle using AC or the PSON# signal.	100		ms
Tsb_vout	Delay from 5 VSB being in regulation to O/Ps being in regulation at AC turn on.	50	1000	ms
Tsb_holdup	Time 5VSB output voltage stays within regulation after loss of AC.	70		ms
Tsb_Vout_rise	The rising time for +5VSB start up to be in regulation	1	25	ms
T12_Vout_rise	The rising time for +12V start up to be in regulation or rising slope 1V/ms	5	20	ms

5.2PS_ON

The PSON# signal is required to remotely turn on/off the power supply. PSON# is an active low signal that turns on the +12 V power rail. When this signal is not pulled low by the system, or left open, the outputs (except the +5 VSB and Vbias) turn off. This signal is pulled to a standby voltage by a pull-up resistor internal to the power supply.

Table 3: PSON# Signal Characteristic

Signal Type	Accepts an open collector/drain input from the system. Pull-up to VSB located in power supply.	
PSON# = Low	ON	
PSON# = Open or High	OFF	
	MIN	MAX
Logic level low (power supply ON)	0 V	1.0 V
Logic level high (power supply OFF)	2.0 V	5.25 V
Source current, Vpson = low		4 mA
Power up delay: T_{pson_on_delay}	5 ms	400 ms
PWOK delay: T_{pson_pwok}		50 ms

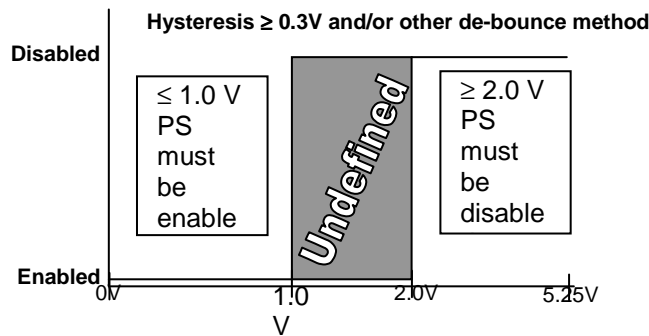

Fig.3 Logic level definition

5.3PWOK(Power OK is on power distribution board)

PWOK is a power OK signal and will be pulled HIGH by the power supply to indicate that all the outputs are within the regulation limits of the power supply. When any output voltage falls below regulation limits or when AC power has been removed for a time sufficiently long so that power supply operation is no longer guaranteed, PWOK will be de-asserted to a LOW state. For a representation of the timing characteristics of PWOK, The start of the PWOK delay time shall be inhibited as long as any power supply output is in current limit.

Table 4: PWOK Signal Characteristics

Signal Type	+5V TTL Compatible output signal	
PWOK = High	Power OK	
PWOK = Low	Power not OK	
	MIN	MAX
Logic level low, Isink = 4mA		0.4 V
Logic level high, Isource = 200µA	2.4 V	5.25 V
PWOK delay: T_{pwok_on}	100 ms	1000 ms
PWOK rise and fall time		100 µs
Power down delay: T_{pwok_off}	1 ms	

5.4AC Warning

Noted on PMBus standard.

5.5LED Indicator

A green/amber double color Light Emitting Diode (LED) shall be mounted as indicated in mechanical drawing and shall indicate the status of the DC GOOD signal with green color. The LED shall continue to glow under normal operation of the power supply. If this LED is blinking or not lit or in amber color, the power supply is not operating properly.

6 I²C and PMBus™ 1.1 standard.

I²C interface has to meet Super Micro standard and PMBus™ 1.1 standard

6.1 Salve address will be 0x70 (default), 0x72, 0x74, 0x76

All the data follows FRU spec.

There is an Internal Area in FRU that is used and defined by vendor (us). Therefore, We use it for health monitoring. It is located in second block (offset 0x08),
Offset 0x09: Temperature,
Offset 0x0A: Fan 1 speed,
Offset 0x0B: Fan 2 speed,
Offset 0x0C: Power Status,
Offset 0x0D: Temperature High Limit,
Offset 0x0E: Fan 1 speed Low Limit,
Offset 0x0F: Fan 2 speed Low Limit.
Offset 0x16: Firmware Version (for example, revision 2.1 would be 0x21).
Offset 0x10-0x15 and 0x17: reserved for future use.

Power Status: bit0 =1 -> GOOD, bit0 = 0 -> Failed

Fan Speed formula: $RPM = (1/0.262) * (Fan Pulse Count * 60 / 2)$

User want to retrieve the FRU data, must follow FRU spec.

Power supply I2C operation shall not latch system I2C bus for over certain time period needed for normal operation. Power supply I2C shall have auto reset function in case of waiting for clock pulse over a reasonable time period.

6.2PMBus

The PMbus firmware version of the power supply shall follow the

1. PMBus Power System Management Specification Part I – General Requirements, Transport and Electrical Interface.
2. PMBus Power System Management Specification Part II – Command Language

The device in the power supply shall be compatible with both SMBus 2.0 'high power' specification for I²C V_{dd} based power and drive (for V_{dd} = 3.3V). This bus shall operate at 3.3V but be tolerant of 5V signaling.

One pin is the Serial Clock [SCL] (PSM Clock). The second pin is used for Serial Data [SDA] (PSM Data). Both pins are bi-directional, open drain signals, and are used to form a serial bus. The circuits inside the power supply shall derive their power from the standby output.

The device shall support SMBus clock-low timeout (Ttimeout). This capability requires the device to abort any transaction and drop off the bus if it detects the clock being held low for >40ms, and be able to respond to new transactions 10ms later.

The device must recognize SMBus START and STOP conditions on ANY clock interval. (These are requirements of the SMBus specifications, but are often missed in first-time hardware designs.) The device must not hang due to 'runt clocks', 'runt data', or other out-of-spec bus timing. This is defined as signals, logic-level glitches, setup, or hold times that are shorter than the minimums specified by the SMBus specification. The device is not required to operate normally, but must return to normal operation once 'in spec' clock and data timing is again received. Note if the device 'misses' a clock from the master due to noise or other bus errors, the device must continue to accept 'in spec' clocks and re-synch with the master on the next START or STOP condition.

6.3 Addressing

System addressing Address2/Address1/Address0	0/0/0	0/0/1	0/1/0	0/1/1
Power supply PMBus™ device	78h	7Ah	7Ch	7Eh

Note: Non-redundant power supplies will use the 0/0/0 address location.

6.4 Command

The following PMBus commands shall be supported for the purpose of monitoring currents, voltages, and power, the detail definition is defined by PMBus™ 1.1 standard.

PMBus command	Description
READ_IIN	RMS input current in amps (note; not used on power distribution boards)
READ_VIN	RMS input voltage in volts (note; not used on power distribution boards)
READ_PIN	AC input power in watts (note; not used on power distribution boards)
READ_VOUT	DC 12V output voltage in volts, the format is set by the VOUT_MODE command.
READ_IOUT	DC 12V output current in amps.
READ_POUT	DC output power in watts.
VOUT_MODE	Command to report the output voltage formatting for the READ_VOUT command.
STATUS_BYTE	Command to report the On/off status of the power supply. Please refer to page 74 of PMbus spec part 2
READ_TEMPERATURE	Read airflow inlet temperature

6.4.1 7.4.0 Accuracy

READ_TEMPERATURE	Desired: +/- 1°C	Required: +/-3 °C
------------------	------------------	-------------------

All data response from PMbus command, except STATUS_BYTE and manufacturer specific commands, are represented in linear format as defined in PMBus spec part 2.

STATUS_BYTE: Please refer to PMbus part 2 spec page 72.

Offset 0x78		
Bit #	7	Not used, default=0
	6	Device is off due to PSON or for any reason (ex. Protection)=1, else 0
	5	Output OVP=1, else 0
	4	Output OCP=1, else 0
	3	Vin under voltage=1, else 0
	2	OTP=1; else 0
	1	Not used, default=0

0	none of the above (Power is good and turned on)=1, else=0
---	---

7.4.1 Manufacturer Specific Commands:

Offset 0xE0 – 0xEB is used to represent the model number, data represented in byte format. These bytes are read only through I2C/PMbus.

Item number		
Offset	character	Hex
E0	P	50
E1	W	57
E2	S	53
E3	-	2D
E4	1	33
E5	K	4B
E6	2	32
E7	1	31
E8	P	50
E9	-	2D
EA	1	33
EB	R	52

Offset 0xF0-0xF5 is used to represent the unit revision number. Revision begins with Rev 1.0. Data is represented in byte format. These bytes are read/write capable using I2C.

Revision		
Offset	character	Hex
F0	R	52
F1	E	45
F2	V	56
F3	1	31
F4	.	2E
F5	0	30

6.5 Sensor Sampling

The sensor registers inside the power supply for monitoring input/output power, current, and voltage shall meet the following minimum requirements. Register refresh rate is the frequency the sensor register gets updated with a new measurement value. Sensor averaging duration is the time over which the data shall averaged to obtain the value of the registers value.

Register refresh rate $\geq 10\text{Hz}$

Sensor averaging duration; $\leq 100\text{msec}$, $\geq 10\text{msec}$

6.6 Accuracy

The sensor commands shall meet the following accuracy requirements.

	20% of max load	50% of max load	100% of max load
READ_IIN (at low line input)	+/-4%	+/-2%	+/-2%
READ_IIN (at high line input)	+/-4%	+/-2%	+/-2%

READ_PIN	+/-7%	+/-5%	+/-5%
READ_IOUT	+/-2%	+/-2%	+/-2%
READ_POUT	+/-3%	+/-3%	+/-3%

READ_VIN	+/- 2% over full range
READ_VOUT	+/- 2% over full range
READ_TEMPERATURE	Desired: +/- 1°C Required: +/-3 °C

7 Protection Circuits

Protection circuits inside the power supply shall cause only the power supply's main outputs to shutdown. If the power supply latches off due to a protection circuit tripping, an AC cycle OFF for 10 seconds and a PSON[#] cycle HIGH for 1 second shall be able to reset the power supply.

7.1 Over Current Protection

The power supply shall have current limit to prevent +12 V outputs from exceeding the values shown in Table 5. If the current limits are exceeded, the power supply shall shutdown and latch off in timing as long as good (about 200ms) with no damage occur to PDB self and power supply. The latch will be cleared by toggling the PSON[#] signal or by an AC power interruption. The power supply shall not be damaged from repeated power cycling in this condition. 5 VSB shall be protected under over current or shorted conditions so that no damage can occur to the power supply. All outputs shall be protected so that no damage occurs to the power supply under a shorted output condition.

Table 5: Over Current Protection

Voltage	Over Current Limit (Iout limit)
+12 V	110% minimum; 130% maximum
+5Vsb (6A Max)	110% minimum; 200% maximum

7.2 240VA Protection

Not applicable

7.3 Over Voltage Protection

The power supply over voltage protection shall be locally sensed. The power supply shall shutdown and latch off after an over voltage condition occurs. This latch shall be cleared by toggling the PSON[#] signal or by an AC power interruption. Table 6 contains the over voltage limits. The values are measured at the output of the power supply's connectors. The voltage shall never exceed the maximum levels when measured at the power pins of the power supply connector during any single point of fail. The voltage shall never trip any lower than the minimum levels when measured at the power pins of the power supply connector.

Table 6: Over Voltage Limits

Output Voltage	MIN (V)	MAX (V)
+12 V	13.3	14.5
+5 VSB	5.7	6.5

7.4 Over Thermal Protection

The power supply over thermal protection shall be locally sensed. The power supply shall shutdown and latch off after an over required temperature condition occurs. This latch shall be cleared by toggling the PSON[#] signal or by

an AC power interruption. The over thermal limits that power supply which components contain required maximum temperature. The temperature shall never exceed the maximum levels when measured at the individual component.

7.5 Short Circuit Protection

All outputs shall be protected and into latch off mode so that no damage occurs to the power supply under a shorted output condition. This latch shall be cleared by toggling the PSON[#] signal or by an AC power interruption.

5Vsb should be protected and into hiccup mode. No damage occurs to the power supply under a shorted output condition, and should be output normally after shorted output released.

8 Environmental Requirements

8.1 Temperature

8.1.1 Normal Operating Ambient(at sea level):

0 degrees Celsius minimum (operating and in standby)

50 degrees Celsius maximum (operating – power supply on)

maximum rate of change is 30 degrees Celsius/hour

8.1.2 Abnormal Operating Ambient(at sea level):

N/A degrees Celsius

N/A survival time

8.2 Humidity

Operating : 20% to 95% RH

Storage : 5% to 95% RH

8.3 Altitude

Operating: to 10,000 feet (3,023 meters)

Non-operating: to 35,000 feet (10,580 meters)

8.4 SHOCK AND VIBRATION

8.4.1 Mechanical Shock

The device will withstand the following imposed conditions without electrical or mechanical failure:

Non-operating Square Wave Shock: 40G, Square wave at 200in/sec (508cm/sec); on all six sides

Non-operating Half Sine Shock: Half Sine pulse for 70in/sec (178cm/sec) for 2ms; on all sides except top

Operating Half Sine Shock: Half Sine pulse for 40in/sec (102cm/sec) for 2ms; on all sides except top

8.4.2 Vibration

Operating: Sinusoidal vibration, 0.5G (0-peak) acceleration. 3-500Hz, sweep at 1/2 octave/min from low to high frequency, and then from high to low. Thirty minute dwell at all resonant points, where resonance is defined as those

exciting frequencies at which the device under test experiences excursions two times larger than non-resonant excursions.

Plane of vibration to be along three mutually perpendicular axis.

Non-operating: Sinusoidal vibration, 1.0G (0-peak) acceleration. 3-500Hz, sweep at 1/2 octave/min from low to high frequency, and then from high to low. Thirty minute dwell at all resonant points, where resonance is defined as those exciting frequencies at which the device under test experiences excursions two times larger than non-resonant excursions.

8.4.3 THERMAL SHOCK

Non-operating: -40 (+/-5) to +70 (+/-5) degrees Celsius, transition time not to exceed 5 minutes. Duration of exposure to temperature extremes will be 20 minutes.

8.5 MTBF and Quality Data

8.5.1 MTBF

The life requirement shall be met the following condition. And the environmental temperature is assumed to be 25 degrees Celsius. Normal operation (at the rated input/output): 150,000h.

9 Regulatory Agency Requirements

The power supply must comply with all regulatory requirements for its intended geographical market as computer server of Information Technology Equipment.

The power supply must meet all regulatory requirements for the intended market at the time of manufacturing. This power supply shall have below certificates for ITE category:

- cUL
- UL
- CCC
- TUV
- CB
- CE
- FCC
- RoHS 6/6
- FCC class A

The power supply itself meets class A with 6 dB margin of EMI limits for CE, FCC, CISPR tested with full output resistance loading, and certificated with CE compliance.

The power supply, when installed in the system, shall meet immunity requirements specified in EN55024. Specific tests are to be EN61000-4-2, -3, -4, -5, -6, -8, and -11. The power supply must maintain normal performance within specified limits. Conformance must be designated with the European Union CE Marking. Specific immunity level requirements are left to customer requirements.

10 Fan Speed Control

When AC plug in, Fans will be on and have minimum speed to cooling power supply to keep normal operating temperature.

The power supply will have internally controlled PWM fans. The PWM fans will be thermal controlled by microcontroller.

Note that speed transition should be non-linear to reduce perceived noise from fan.

Pin 17 implement a function for system control power fan speed into normal or quiet mode go through power PDB same pin to empty pin (was for -5V) output on 24pin or 20pin connector.

5V TTL Low @ pin 17 – Fan operate in quiet mode

5V TTL High or no connection @ pin 17 – Fan operate in normal (default setting)

Fan control speed rule is shown in the attached file below.



PWM Fan Control
Design Guideline 0.1.

11 Output Connector and Dimension

The power supply will provide a card edge connector compatible with the backplane. See power supply mechanical drawing for dimensions. The power supply connector is a 6 blade (3 pair) and 20 pins (10 pair) edge connection type from Tyco Electronics, Mfr P/N 1489958-1 or FCI P/N 10034908 connector or equivalent one.

Power and Signal Connection

Description	Pin Number	I/O	Active	Pin Length
Ishare	1		Analog	Standard
A1 (address)	2	I/O	High/Low	Standard
A2 (address)	3	I/O	High/Low	Standard
I2C SCL	4	I/O	High/Low	Standard
I2C SDA	5	I/O	High/Low	Standard
PS ON/OFF	6	I	Low	Short (by 1mm)
Spare	7			
DC GOOD	8	O (+12V)	High	Standard
+12V	9		Power Pin	Standard
+12V	10		Power Pin	Standard
+12V	11		Power Pin	Standard
+12V	12		Power Pin	Standard
+12V	13		Power Pin	Standard
RS GND	14		Analog	Standard
Spare	15			
12V RS GND	16		Analog	Standard
Fan Control	17	I	High	Standard
DC Return	18		Power Pin	Standard
5Vsb CO	19		Power Pin	Standard
5Vsb CO	20		Power Pin	Standard
DC Return	21		Power Pin	Standard
DC Return	22		Power Pin	Standard
DC Return	23		Power Pin	Standard
DC Return	24		Power Pin	Standard
DC Return	25		Power Pin	Standard
DC Return	26		Power Pin	Standard

.Note: The signal pins on the power supply connector will be gold plated to 30 microns.

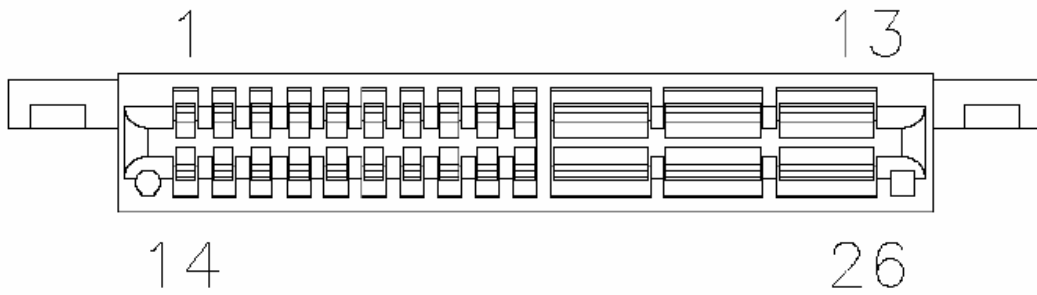

The power dimension is same current PWS-801-1R

Barcode: P1K23CYWWRMSSSS.

12 Assembly Process

Supermicro confirms the assembly process, test process. If they have a problem, Supermicro requests to improve the problem.

13 Safety

13.1 Dielectric Strength Testing (Hi-pot)

All units must pass a 1500VAC line to ground/chassis hi-pot test. The voltage must be maintained at that level for a minimum of 1 second without failure.

13.2 Ground Continuity Testing

All units must pass a ground continuity test with less 0.1 Ohm from the ground (third wire) input pin to the chassis.

14. outside mechanical drawing

