



J2012-03-35X

**2U12 35X 12G HS JBOD
User's Manual**

Table of Contents

Preface	i
Safety Instructions	ii
About This Manual	iv
Chapter 1. Product Features	1
1.1 Box Content.....	1
1.2 Specifications	2
1.3 Feature.....	3
Chapter 2. Hardware Setup	6
2.1 Top Cover	6
2.2 Power Supply Unit	7
2.2.1 Installation	7
2.3 Fan	8
2.4 Disk Drive	9
2.4.1 External 3.5-inch Disk Drive.....	9
2.4.2 Drive Slot Map	10
2.5 Expander	11
2.6 Slide Rail	12
Chapter 3 Sub-system Configuration Setup	15
3.1 Supported Configuration and Unsupported Feature	15
3.1.1 Supported Configuration	15
3.2 Utility Setup on Host.....	16
3.3 Expander Firmware Update via Expander Console Port	19
3.4 Expander Firmware Configuration.....	21
3.4.1 Configure Serial Command Line Interface	21
3.4.2 SES Inband Features.....	24
3.4.3 SES vendor specific page: Chassis Number (page code 82h) Out / In	25
3.4.4 SES vendor specific page: Canister Number (page code 83h) Out / In.....	25
3.4.5 SES vendor specific page: Drive Bay Blue LED (page code 8Bh) Out / In	26
3.5 Implementation on SES Elements	26
3.5.1 Power Supply Element	26
3.5.2 Cooling Element	27
3.5.3 Temperature Sensor Element.....	28
3.5.4 Enclosure Element	30
3.5.5 Voltage Element	31
3.5.6 Array Device Element	32
3.6 SES Element Control Functions.....	34
3.6.1 LED indicators (blue and red) associated with an attached disk drive.....	34
3.6.2 How to turn on/off the power of a drive bay	35
3.6.3 How to power off/on all drive bays manually.....	36
3.6.4 How to enable/disable the enclosure alarm by your software.....	36
3.6.5 How to manually change PWM (fan speed) for all Cooling elements.....	37
3.7 Vendor Specific Vital Product Data (VPD) Page	38
Chapter 4. Technical Support.....	39



Copyright © 2021 AIC®, Inc. All Rights Reserved.

This document contains proprietary information about AIC® products and is not to be disclosed or used except in accordance with applicable agreements.

Document Release History

Release Date	Version	Update Content
January, 2022	1	Release to public.
May, 2023	1.1	Update specification.
June, 2024	1.2	Update datasheet and LED indicator of rear panel.

Preface

Copyright

No part of this publication may be reproduced, stored in a retrieval system, or transmitted in any form or by any means, electronic, mechanical, photo-static, recording or otherwise, without the prior written consent of the manufacturer.

Trademarks

All products and trade names used in this document are trademarks or registered trademarks of their respective holders.

Changes

The material in this document is for information purposes only and is subject to change without notice.

Warning

1. A shielded-type power cord is required in order to meet FCC emission limits and also to prevent interference to the nearby radio and television reception. It is essential that only the supplied power cord be used.
2. Use only shielded cables to connect I/O devices to this equipment.
3. You are cautioned that changes or modifications not expressly approved by the party responsible for compliance could void your authority to operate the equipment.

Disclaimer

AIC® shall not be liable for technical or editorial errors or omissions contained herein. The information provided is provided "as is" without warranty of any kind. To the extent permitted by law, neither AIC® or its affiliates, subcontractors or suppliers will be liable for incidental, special or consequential damages including downtime cost; lost profits; damages relating to the procurement of substitute products or services; or damages for loss of data, or software restoration. The information in this document is subject to change without notice.

Instruction Symbols

Special attention should be given to the instruction symbols below.



NOTE

This symbol indicates that there is an explanatory or supplementary instruction.



CAUTION

This symbol denotes possible hardware impairment. Upmost precaution must be taken to prevent serious hardware damage.



WARNING

This symbol serves as a warning alert for potential body injury. The user may suffer possible injury from disregard or lack of attention.

Safety Instructions

Before you commence, please attentively read the following important discretions below. All cautions and warnings on the equipment or in the manuals should be circumspactly noted and reviewed.

Always ground yourself to prevent static electricity.

請全程接地，以防止靜電。

请全程接地，以防止静电。

Всегда заземляйте себя, чтобы избежать статического электричества.

Aard jezelf altijd om statische elektriciteit te voorkomen.

- Firmly ground yourself at all times when installing or assembling the internal components of the server. Most of electronic components in the server are highly sensitive to electrical static discharge.
- Use a solid grounding wrist strap and distinctively place all electronic components in static-shielded devices to prevent static. Grounding wrist straps can be purchased in any electronic supply store.
- Confirm that the power source is turned off and then disconnect the power cords from your system before performing any type of installation or manual servicing. A sudden surge of power could severely damage the sensitive electronic components.
- Do not precipitously open the system's top cover. If you must open the cover for maintenance purposes, only a trained technician should be allowed to proceed this action. Integrated circuits on computer boards are highly sensitive to static electricity. Before operating a board or integrated circuit, touch an unpainted portion of the system unit chassis for a couple of seconds to discharge any static electricity on your body.

Place the server in a stable environment.

請將伺服器放置在穩定的環境中。

请将伺服器放置在穩定的環境中。

Поместите сервер в стабильную среду.

Plaats de server in een stabiele omgeving.

- Place this equipment on a stable surface when installing. A small mild drop or fall could cause fatal injury to both the equipment and the person handling the equipment.
- Please keep this equipment away from humidity to prevent vast rust and disintegration.
- Carefully and accurately mount the equipment into the rack. Uneven mechanical loading may lead to hazardous consequences.
- This equipment is to be installed for operation in an environment with maximum ambient temperature below 35°C.
- Review the environment before performing any installation or servicing. Keep the equipment away from hazardous and uneven grounds.
- This server must be installed only in Restricted Access Locations.

Handle equipment with care.

請謹慎操作設備。

请谨慎操作设备。

Обращайтесь с оборудованием осторожно.

Behandel de apparatuur voorzichtig.

- Do not cover the openings of the system. The openings on the system are for air convection, which intentionally protect the equipment from overheating.
- Never pour any liquid into ventilation openings of the system. This could cause catastrophic fire or electrical shock.

- Ensure that the voltage of the power source is within the specification on the label when connecting the equipment to the power outlet. The current load and output power of loads must be within the specification.
- This equipment must be firmly connected to reliable grounding before usage. Pay special attention to power supplied other than direct connections, e.g. using of power strips.
- Place the power cord out of the way of foot traffic. Do not place anything over the power cord. The power cord must be rated for the product, voltage and current marked on the product's electrical ratings label. The voltage and current rating of the cord should be greater than the voltage and current rating marked on the product.

Pay attention to hardware maintenance.

注意硬體維護。

注意硬體維護。

Обратите внимание на обслуживание оборудования.

Besteed aandacht aan hardware-onderhoud.

- If the equipment is not used for a long time, disconnect the equipment from mains to avoid being damaged by transient over-voltage.
- Module and drive bays must not be empty. They must have a dummy cover.
- Never open the equipment without professional assistance. For safety reasons, only qualified service personnel should open the equipment.
- If one of the following situations arise, the equipment should be checked and tested by service personnel:
 1. The power cord or plug is damaged.
 2. Liquid has penetrated the equipment.
 3. The equipment has been exposed to moisture.
 4. The equipment does not work well or will not work according to its user manual.
 5. The equipment has been dropped and/or damaged.
 6. The equipment has obvious signs of breakage.
 7. Please disconnect this equipment from the AC outlet before cleaning. Do not use liquid or detergent for cleaning. The use of a moisture sheet or cloth is recommended for cleaning.



CAUTION

The equipment intended for installation should be placed in Restricted Access Location.



CAUTION

There will be a risk of explosion if battery is replaced by an incorrect type. Dispose of used batteries according to the instructions. After performing any installation or servicing, make sure the enclosure is correct in position before turning on the power.



CAUTION

This unit may have more than one power supply. Disconnect all power sources before maintenance to avoid electric shock.



About This Manual

Thank you for selecting and purchasing J2012-03-35X.

This user's manual is provided for professional technicians to perform easy hardware setup, basic system configurations, and quick software startup. This document pellucidly presents a brief overview of the product design, device installation, and firmware settings for J2012-03-35X. For the latest version of this user's manual, please refer to the AIC® website: <https://www.aicipc.com/en/productdetail/51327>.

Chapter 1 Product Features

J2012-03-35X is an ideal SAS JBOD that is specifically designed to accommodate diverse corporations and enterprises who pursue flexibility, easy control, and density in external or backup storage. This product supports designs and is easily deployed for your benefit.

Chapter 2 Hardware Setup

This chapter displays an easy installation guide for assembling the main components of the JBOD. Utmost caution for proceeding to set up the hardware is highly advised. Do not endanger yourself by placing the device in an unstable environment. The consequences for negligent actions may be extremely severe.

Chapter 3 Sub-system Configuration Setup

This chapter provides details about the supported features and unsupported configurations about your host(s) and expander controller connection.

Chapter 4 Technical Support

For more information or suggestion, please contact the nearest AIC® corporation representative in your district or visit the AIC® website: <https://www.aicipc.com/en/index>. It is our greatest honor to provide the best service for our customers.

Chapter 1. Product Features

J2012-03-35X is a high performance JBOD product that includes 12 x 3.5" hot swap drive bays and single/dual expander module(s). For more information about our product, please visit our website at <https://www.aicpc.com/en/index>.

Before removing the subsystem from the shipping carton, visually inspect the physical condition of the shipping carton. Exterior damage to the shipping carton may indicate that the contents of the carton are damaged. If any damage is found, do not remove the components; contact the dealer where the subsystem was purchased for further instructions. Before continuing, first unpack the subsystem and verify that the contents of the shipping carton are all there and in good condition.

1.1 Box Content

This product contains the components listed below.

Please confirm the number and the condition of the components before installation.

Pre-installed into the system		Number
✓	550W redundant power supply 80+ Platinum	1+1
✓	3.5-inch external hot swap disk drive tray	12
✓	Hot swap 60*56mm fan	2
Accessory Item		Number
✓	EPE foam for front board: 563*300*105H	1
✓	EPE foam for rear board: 563*300*105H	1
✓	EPE foam for front tray: 563*300*145H	1
✓	EPE foam for rear tray: 563*300*145H	1
✓	EPE pad for rail: 130*100*70T	2
✓	EPE pad for rail box: 130*100*20T	2
BTO	Power cord	vary per region
BTO	20-inch tool-less slide rail assembly	1
BTO	Adjustable plate	1

Product features are subject to change without notice.

1.2 Specifications

General	Number of Expander	Single/Dual	Electrical and Environmental	Universal A/C Input	Platinum: • 100~127V~, 50/60Hz, 7.0 A • 200~240V~, 50/60Hz, 3.5 A Titanium: • 100-127V~,50/60Hz,10 A • 200-240V~,50/60Hz, 5 A
	Expander Chip	LSI SAS35X40			
	Host/Expansion Interface	4 x Mini SAS HD (SFF-8644) per expander module			
Drives Supported	Drive Interface	• 12Gb & 6Gb SAS if using dual expanders • 12Gb & 6Gb SAS/SATA if using single expander		Operating Environment	• Temperature : 0°C to 35° C • Relative humidity : 20% to 80 %
	Form Factor	3.5"		Non-operating Environment	• Storage temperature : -20° ~ 60° C • System relative humidity : 10% - 90%
Administration / Management	Admin/Firmware Upgrade	• In-band & Serial port interface • IEM port		Physical Specification	Dimensions (W x D x H)
	LED indicators, Audible Alarm	Yes	inches : 17.2 x 15.2 x 3.5		
Hot swap and Redundancy	Drive Bays	12	Gross Weight (w/ PSU, Rail; w/o Pallet, Disks)		kgs : 20.98
	Cooling	2 x 60x56mm hot swap fans			lbs : 46.25
	Power Supply (options)	550W 1+1 hot swap redundant 80+ Platinum 800W 1+1 hot swap redundant 80+ Titanium	Packaging Dimensions (W x D x H)		mm : 605 x 680 x 318
Power Entry	Dual AC Inlet	inches : 23.8 x 26.8 x 12.5			
Hot swap and Redundancy	Expander Modules	Dual expanders (Optional)	Mounting	Standard	20" tool-less rail





J2012-03-35X is a reliable SAS JBOD with 12 hot swap drive bays. This product is designed to accommodate single/dual expanders with 4 Mini SAS HD wide ports. Featuring the expander chip, Broadcom SAS35x40, which is underscored for its high scalability and performance of supporting up to 12 Gb/s, this product enhances these features by integrating designs, redundant fans, and expansion to offer easy control and high performance for our customers.

- Ruggedized design (internal board to board connection)
- Tool-less design
- Hot-swap expander module, drives, PSU and fans
- Short-depth
- Clear front panel LED indicators
- Optimized thermal solution
- BMC onboard

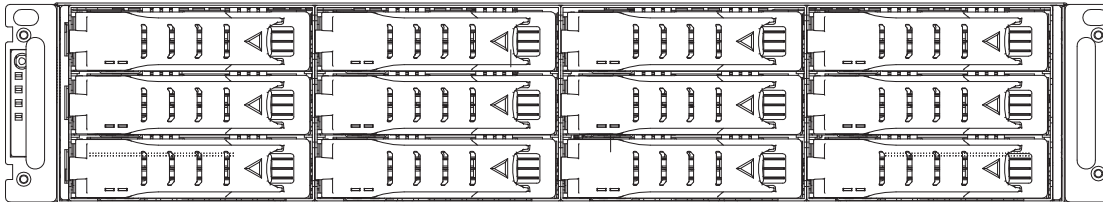
1.3 Feature

Front Panel



Item	Description		
	Power Button	Normal	Off
		Press	Boot up
		Long Press	System shutdown
	Power Status LED	On	Blue
		Off	Off
		ID	Blue (blinking)
	Power Failure LED	Normal	Off
		Failed	Red
	Temperature Failure LED	Normal	Off
		Failed	Red
	Fan Fault Status LED	Normal	Off
		Failed	Red

Rear Panel

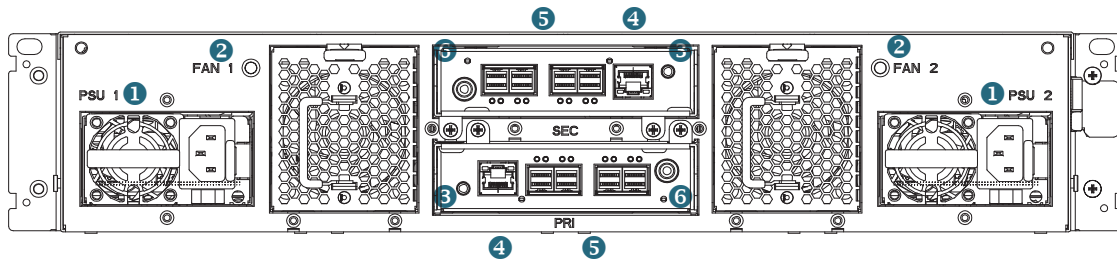

Item	Description
1	550W 1+1 redundant power supply 80+ Platinum
2	2 * 60*56 hot swap fan
3	1 * BMC console port per expander
4	1 * GbE RJ45 dedicated to BMC management ports per expander
5	4 * Mini SAS HD wide ports per expander
6	1 * Expander console port per expander

LED Indicator

Item	Color	Description
PSU LED	Green	OK
	Green (blinking)	Ready
	Amber	Failed
	Amber (blinking)	Warning
Fan LED	Green	Normal
	Red	Failed
Expander SAS ports LED	Off	No connection
	Blue	Normal
	Red	Failed
Expander BMC LED	Blue (blinking)	Normal
	Red	Get sensor failed
Expander ID LED	Off	Normal
	Blue (blinking)	Identity

Top View

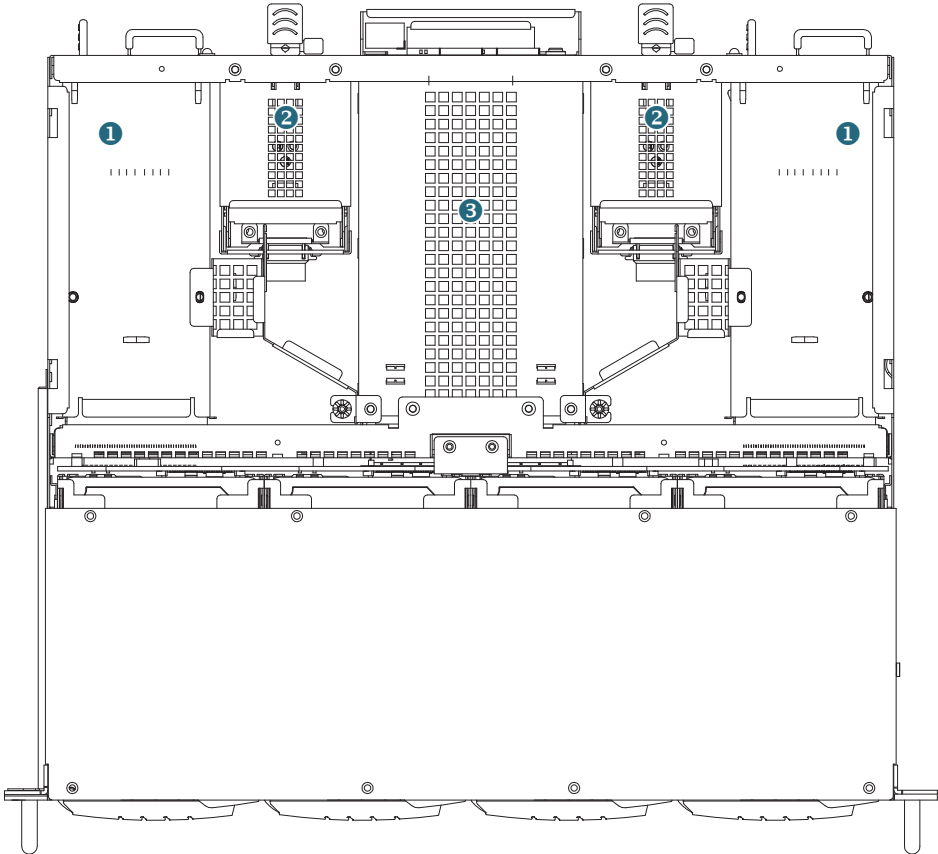

Item	Description
1	550W 1+1 redundant power supply 80+ Platinum
2	2 * 60*56 hot swap fan
3	Single/dual Expander(s)

Chapter 2. Hardware Setup

2.1 Top Cover

- ① Dislodge the screws on the top cover.
- ② Push the cover towards the rear panel.
- ③ Lift upward to remove.

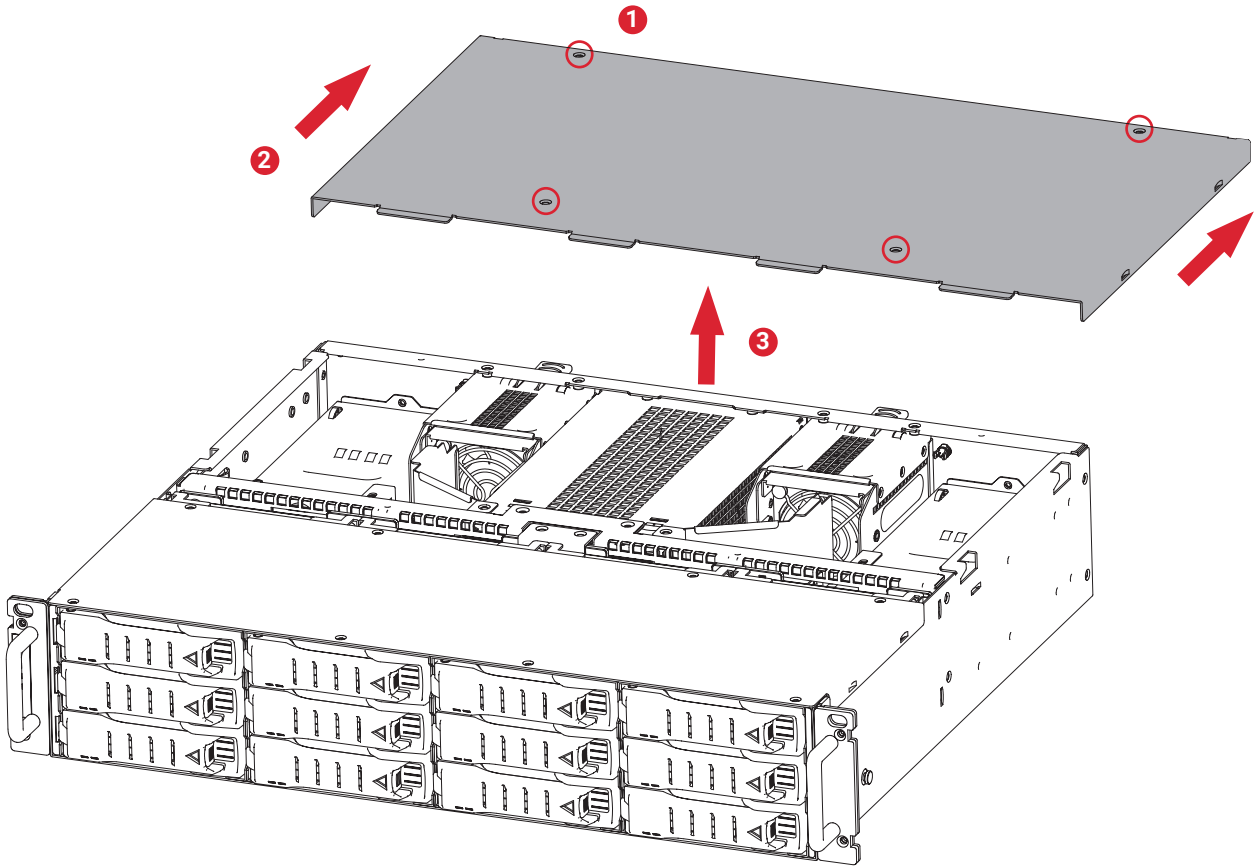

This information is provided for professional technicians only.

2.2 Power Supply Unit

2.2.1 Installation

- ① Press the ejector to release the module.
- ② Pull the handle to remove the module out of the chassis.
- ③ Push the replaced power supply unit into the chassis. Ensure that the module is hooked into the cage.

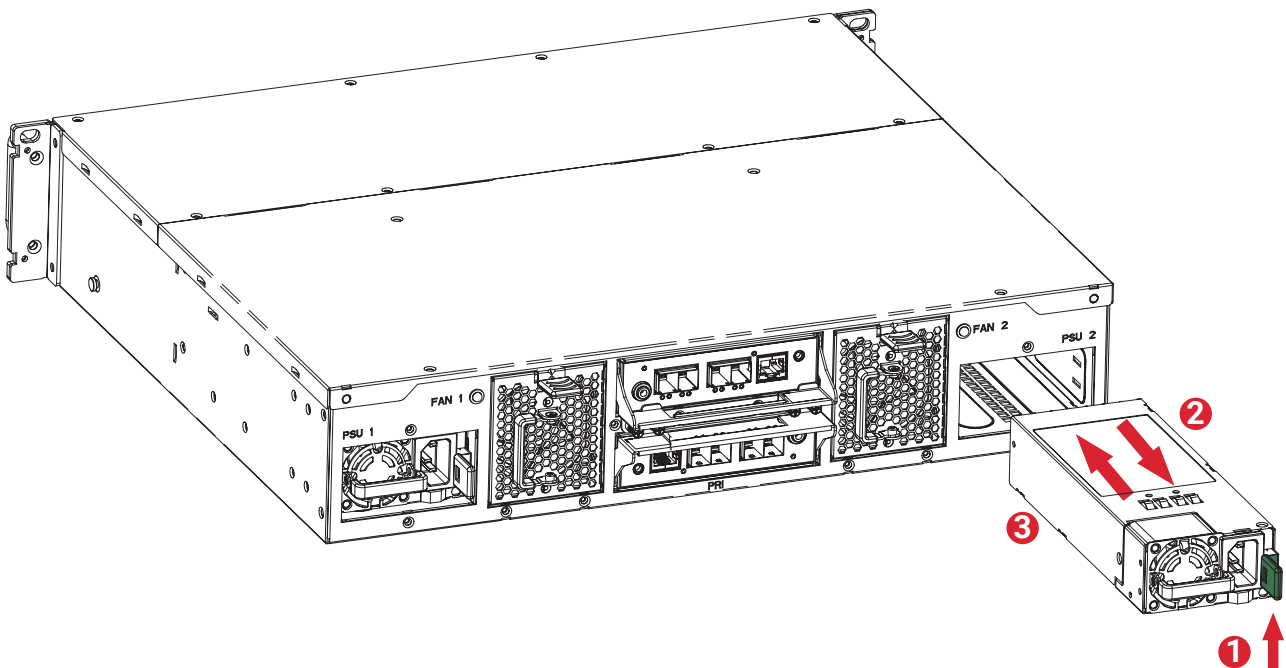

2.2.2 LED Indicator

Indicator Color	Behavior
Green (solid)	Power is on.
Green (blinking)	Only 12Vsb (PS off) or PSU is in cold redundant state
Amber(solid)	Power has failed.
Amber (blinking)	Power supply warning events where the power supply contributes to operate high temperature, high power , high current, slow fan.



This information is provided for professional technicians only.

2.3 Fan

- ① Press the ejector to release the module.
- ② Pull the handle to remove the module out of the chassis.
- ③ Push the replaced fan into the chassis. Ensure that the module is hooked into the cage.

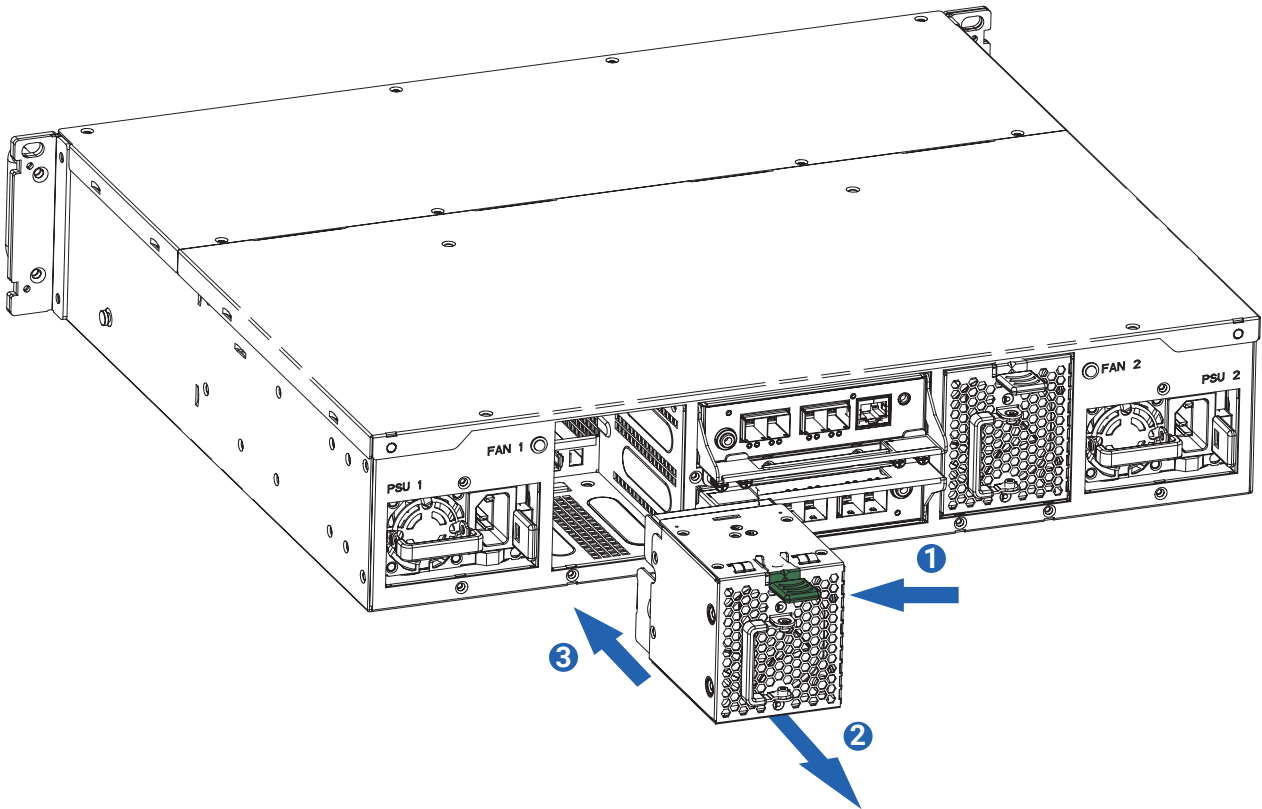

Rear Panel

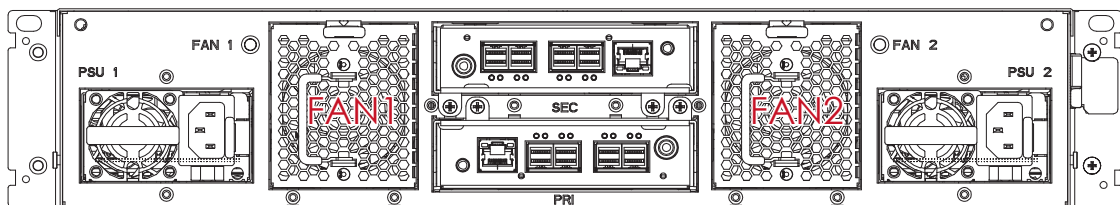

This information is provided for professional technicians only.

2.4 Disk Drive

2.4.1 External 3.5-inch Disk Drive

- ① Press the ejector on the tray to release the handle.
- ② Pull the tray handle completely outward.
- ③ Pull the drive tray out of the chassis.

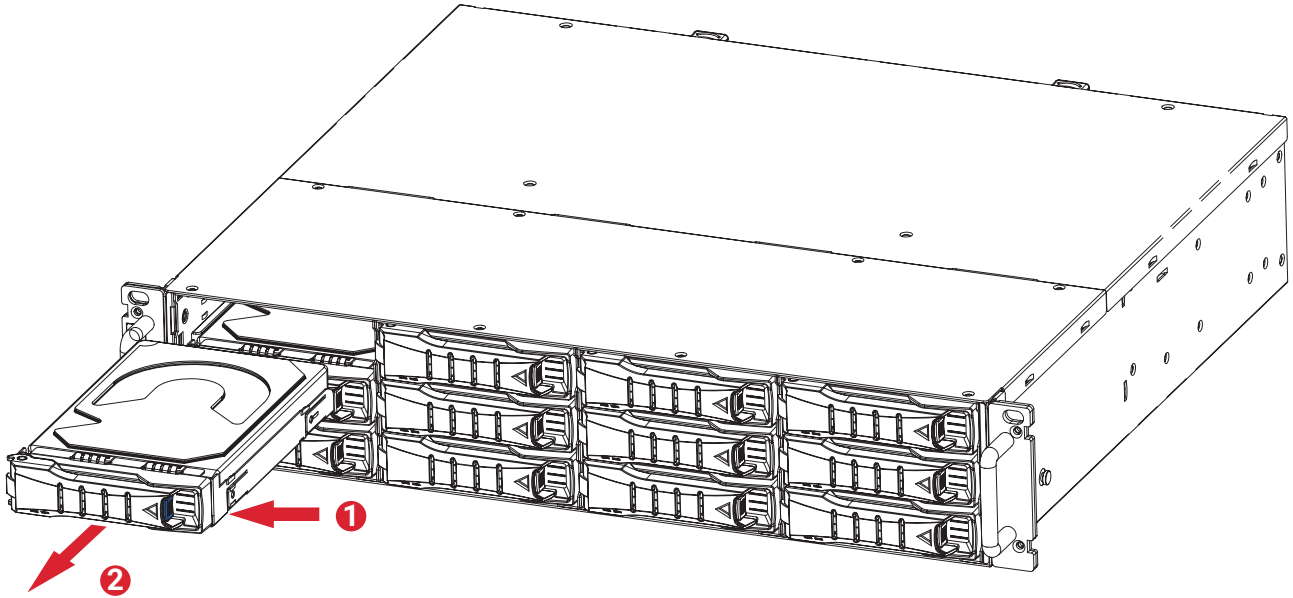

- ④ Insert the hard disk drive into the tray. Ensure that the dimples on the tray match the hard disk drive. For additional assurance, fasten the screws * 2 on the tray to secure the disk drive.

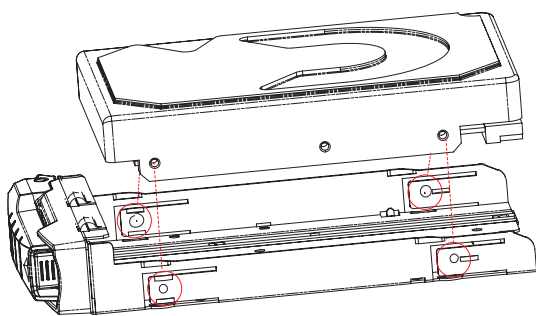

3.5" HDD dimple placement

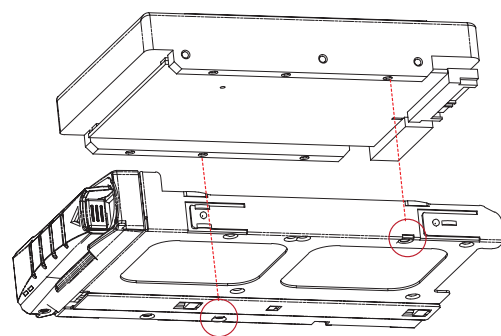

3.5" HDD screw placement

- ⑤ Push the tray with the installed disk drive into the end of the drive slot in the chassis.
- ⑥ Close the tray handle.



This information is provided for professional technicians only.

2.4.2 Drive Slot Map

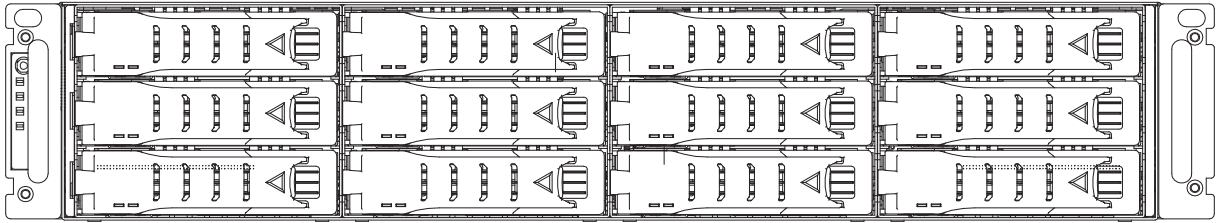

1	2	3	4
5	6	7	8
9	10	11	12

2.4.3 LED Indicator

Indicator	Behavior	Description
Blue	Solid	SATA/SAS drive is present.
	Blinking	SATA/SAS is accessed or located.
	Off	SATA/SAS is not detected or the system power is off.
Red	Solid	SATA/SAS is in locate status or there is a drive fault.
	Blinking	SATA/SAS is in rebuilding status.
	Off	SATA/SAS is functioning normally.

2.5 Expander

- ① Loosen the captive screw on the module.
- ② Pull the tray handle to remove the expander.

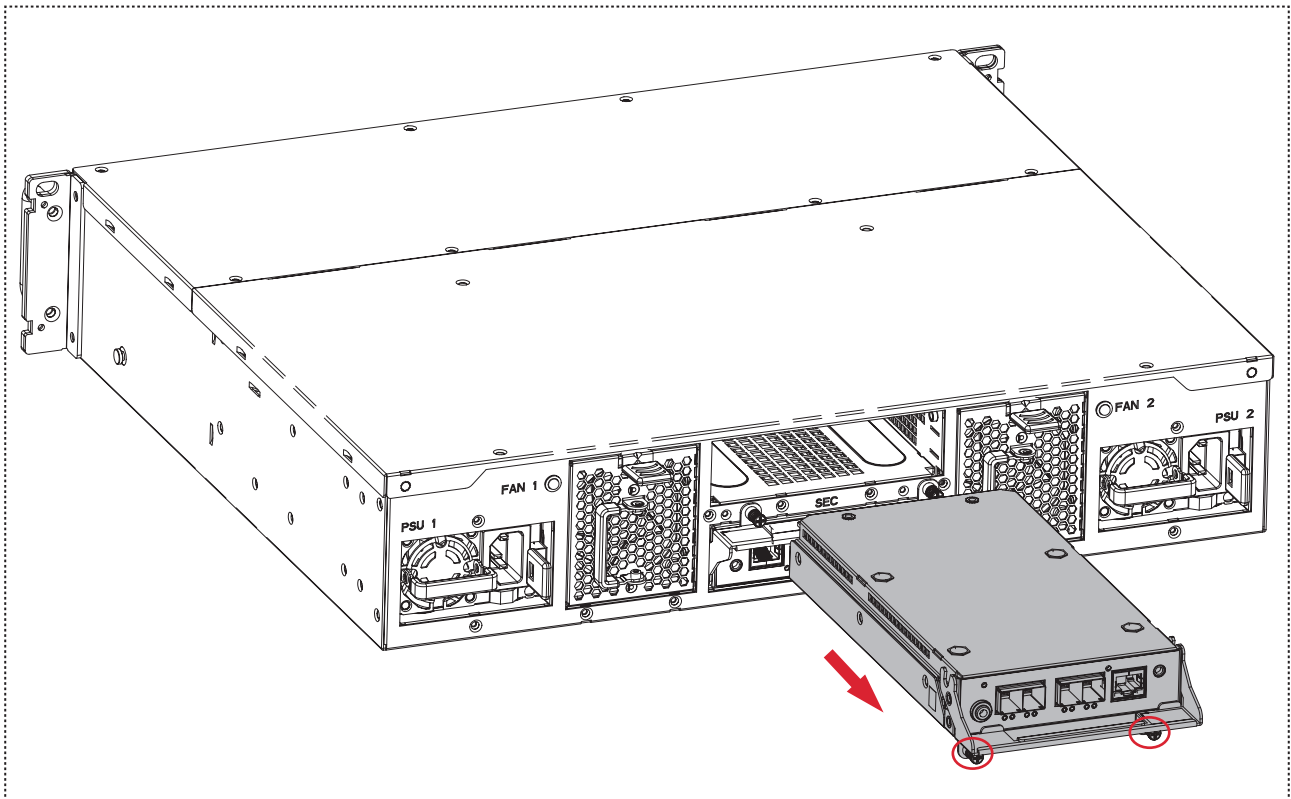

Rear Panel

Secondary Expander

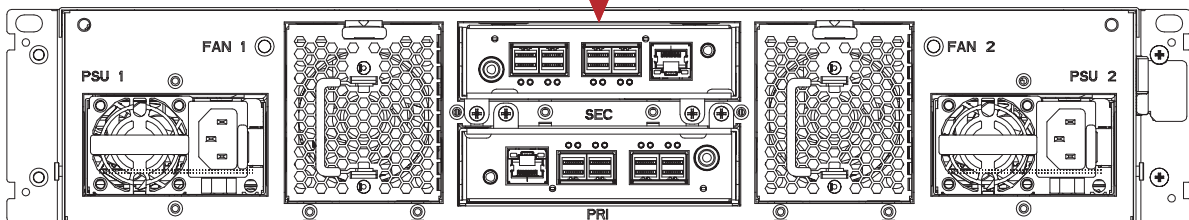

Primary Expander



This information is provided for professional technicians only.

2.6 Slide Rail

NOTE



This sections provides the basic dimensions of the mounting the slide rail. Tool-less rails vary per order. The rail in this manual may not exactly match the rail for your system. Please refer to the specifications or quick installation guide that came with your purchased product.

NOTE



The product installation position is less than 1 meter in height from the supporting surface.

NOTE



This slide rail can only be affixed to a 438mm width chassis.

Slide Rail Side View

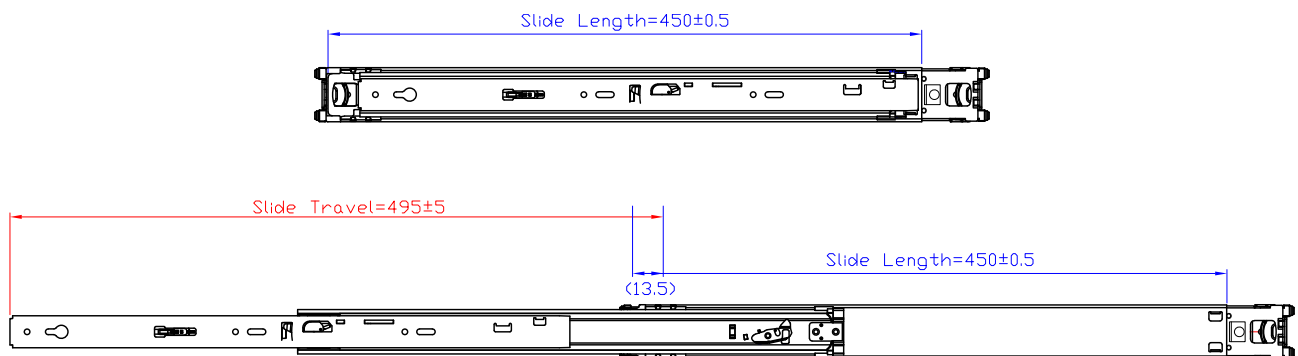

1. Pull the front release to unlock the inner channel from the slide assembly.

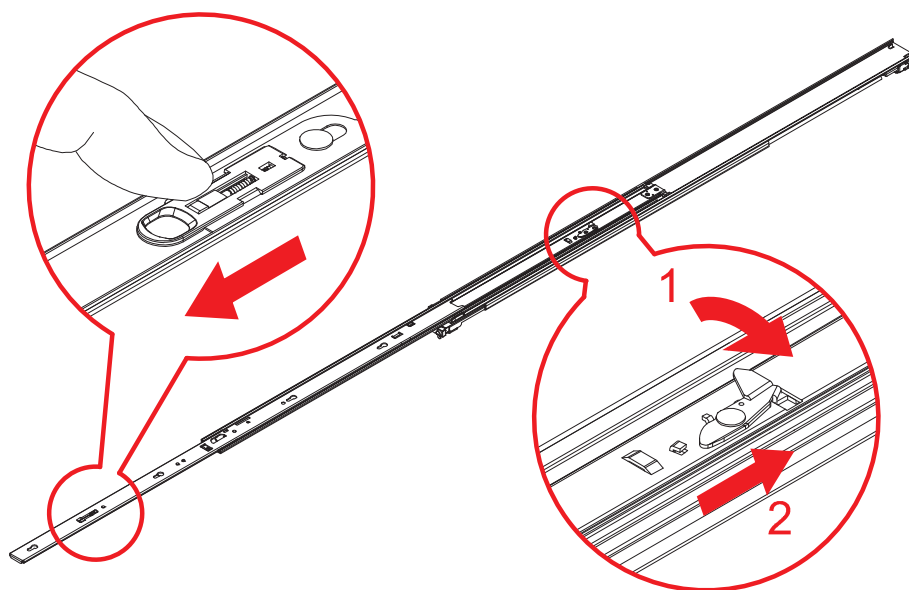

2. Release the detent-lock and push the middle channel inwards to retract the middle channel.

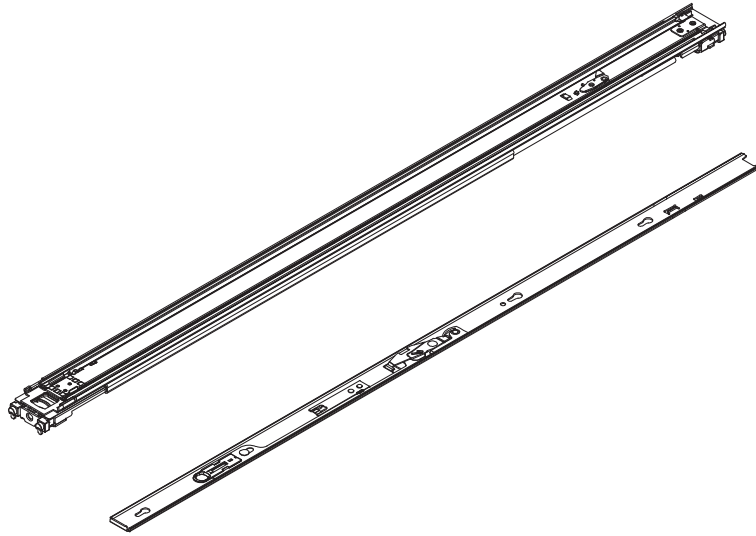

3. Install the slide rail onto the rack frame.
- Stretch and adjust the rear bracket to fit the length of the rack frame.
 - Push and hold the trigger on the back bracket to expose the metal hooks. Align and insert the bracket with the mounting holes on the rack frame. Release the trigger.

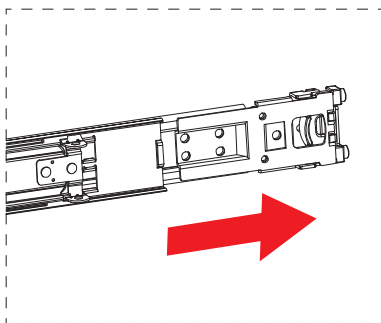

a. Stretch

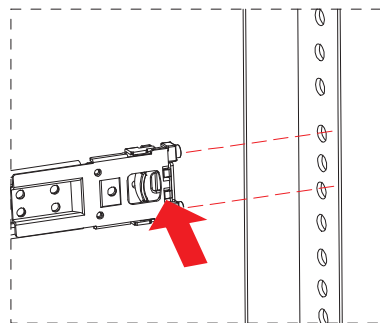

b. Align and insert

- Align and insert the front bracket with the mounting hole.
- Fix the bracket onto the frame rack. Attach the rail post with M5x10L screws for additional security if needed.

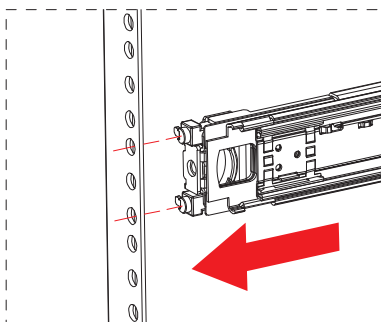

c. Align

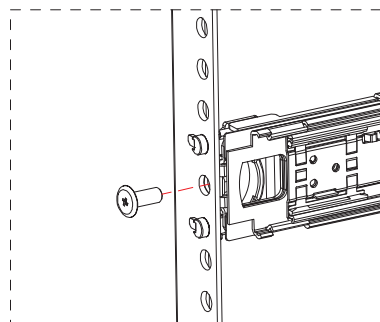

d. Secure with screw (optional)

4. Assemble the Inner channel onto the chassis using the screws provided.

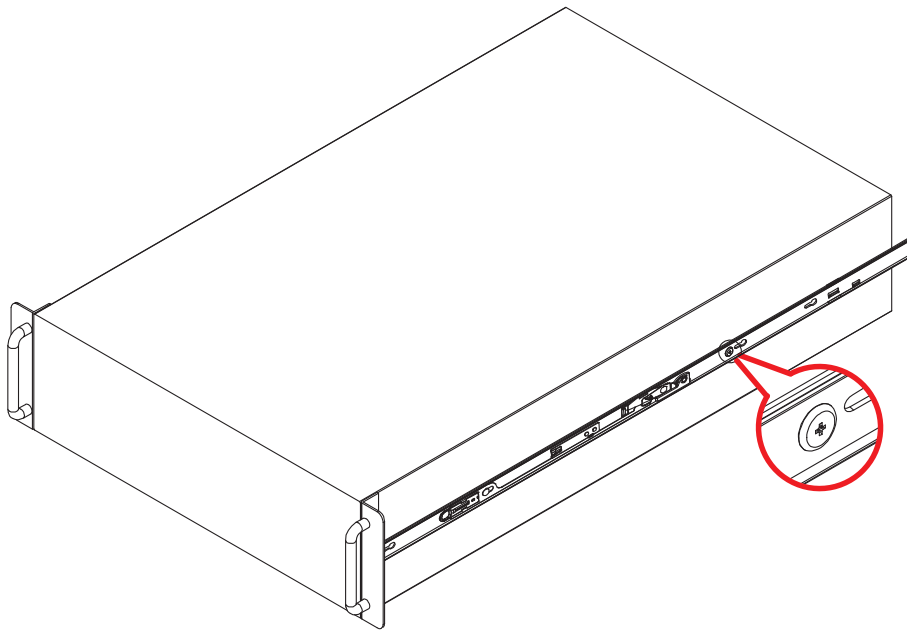

5. Push the chassis with Inner channels into the slide to complete rack installation.

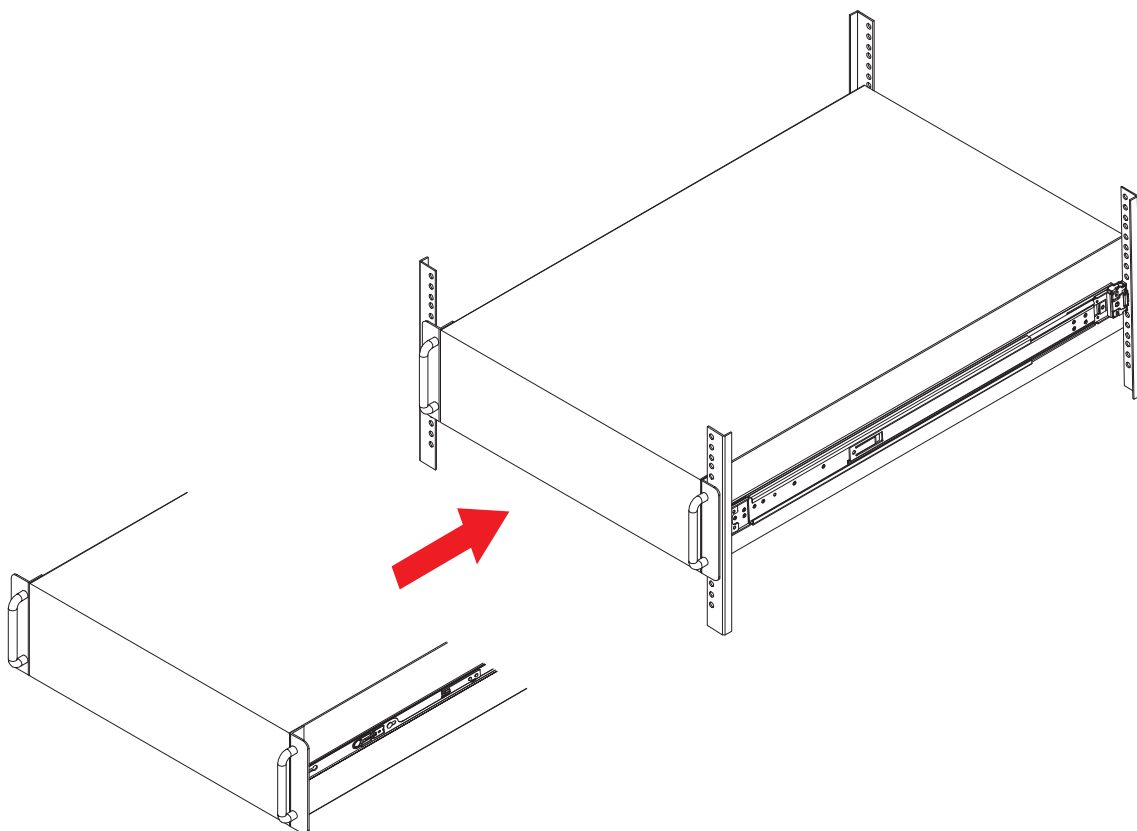

Chapter 3 Sub-system Configuration Setup

3.1 Supported Configuration and Unsupported Feature

3.1.1 Supported Configuration

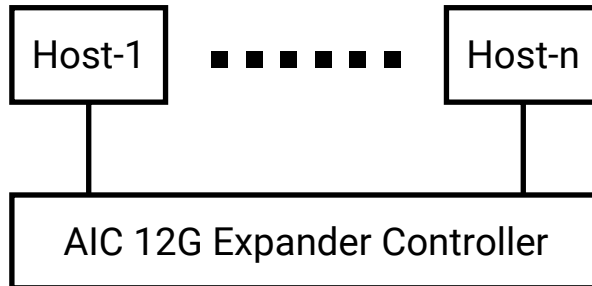

To have multiple host/path access support (the host number can be up to the number of wide ports on each AIC 12G Expander Controller), only the following drives are supported for shared access:

- (A) SAS drive / Nearline SAS drive
- (B) SATA drive with an interposer which provides SATA-to-SAS conversion

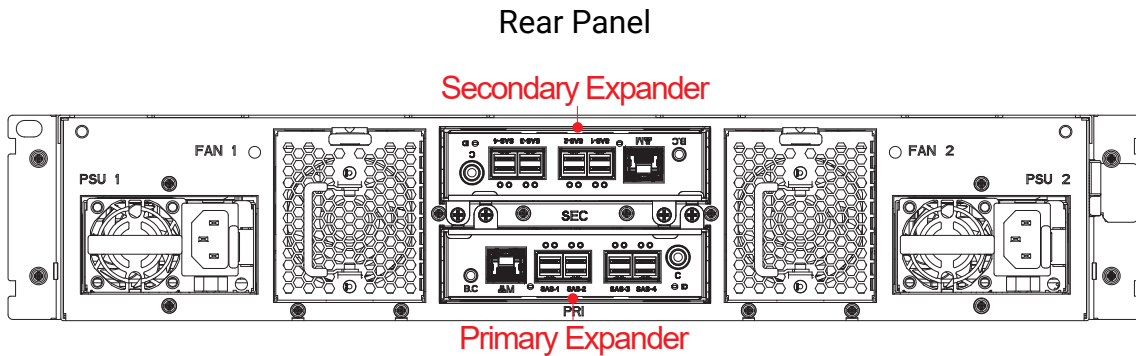

3.2 Utility Setup on Host

Step 1. Connect host to BMC with RS232 cable.

Step 2. Open the terminal utility, set Connection type: "Serial", Speed: "38400".

Step 3. Push the "F" key, it will show the IPMI Terminal Interface.

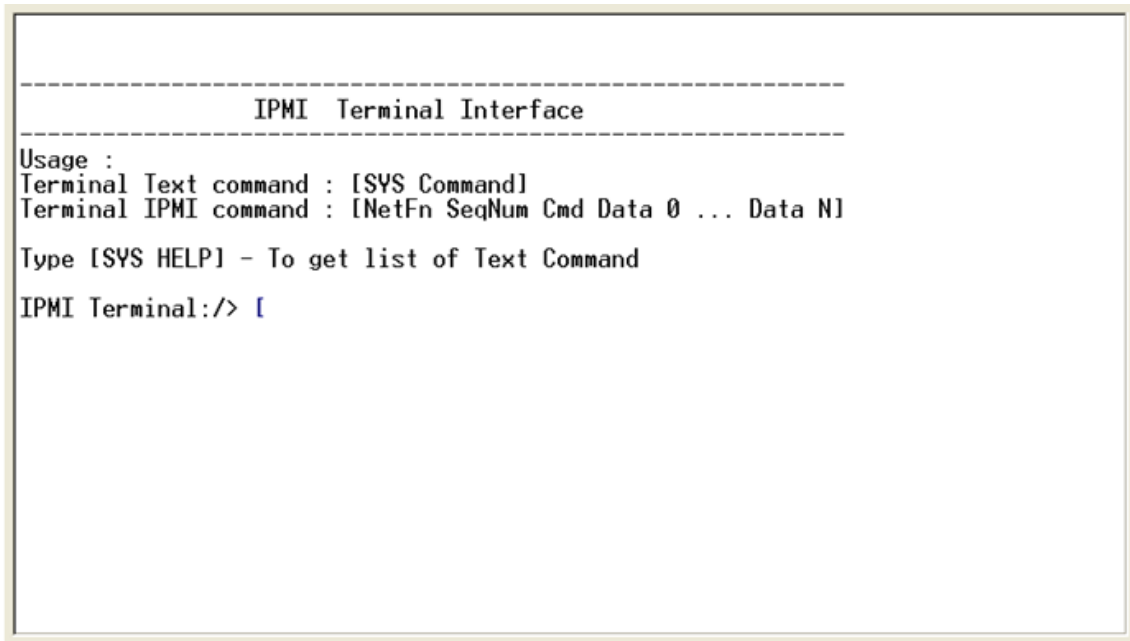

```

-----
                    IPMI Terminal Interface
-----
Usage :
Terminal Text command : [SYS Command]
Terminal IPMI command : [NetFn SeqNum Cmd Data 0 ... Data N]

Type [SYS HELP] - To get list of Text Command

IPMI Terminal: /> [

```

Step 4. Type in this command to login the interface.

Default USERNAME is "ADMIN", PASSWORD is "ADMIN".
(Or USERNAME is "admin", PASSWORD is "admin".)

Example:

IPMI Terminal: /> [sys pwd -u USERNAME PASSWORD]

It will respond [OK]

Step 5. Type in the command to change the password.

Need to change the password to obtain the authorization of the following commands.

Example:

Try to set password as "12345678", password size is 16 bytes.

IPMI Terminal: /> [18 00 47 02 02 31 32 33 34 35 36 37 38 00 00 00 00 00 00 00]

Refer ASCII table: Hex 31 = Dec 49 = "1"

It will respond [1C 00 47 00]

Byte3: Completion code "00" means received and admitted. Login with the new password.

Step 6. Find the LAN Configuration.

Example:

Find the LAN IP Address Source.

IPMI Terminal: /> [30 00 02 01 04 00 00]

It will respond [34 00 02 00 11 02]

Byte3: Completion code "00" means received and admitted.

Byte5: "01" is static address (manually configured), "02" is DHCP.

Find the LAN IP Address.

IPMI Terminal: /> [30 00 02 01 03 00 00]

It will respond [34 00 02 00 11 C0 A8 64 0A]

Byte3: Completion code "00" means received and admitted.

Byte5~8: IP Address

"C0" is hexadecimal, convert to decimal is "192".

"A8" is hexadecimal, convert to decimal is "168".

"64" is hexadecimal, convert to decimal is "100".

"0A" is hexadecimal, convert to decimal is "10".

Find the Subnet Mask.

IPMI Terminal: /> [30 00 02 01 06 00 00]

It will respond [34 00 02 00 11 FF FF FF 00]

Byte3: Completion code "00" means received and admitted.

Byte5~8: Subnet Mask

"FF" is hexadecimal, convert to decimal is "255".

Find the Gateway Address.

IPMI Terminal: /> [30 00 02 01 0C 00 00]

It will respond [34 00 02 00 11 C0 A8 64 01]

Byte3: Completion code "00" means received and admitted.

Byte5~8: Gateway

"C0" is hexadecimal, convert to decimal is "192".

"A8" is hexadecimal, convert to decimal is "168".

"64" is hexadecimal, convert to decimal is "100".

"01" is hexadecimal, convert to decimal is "1".

Step 7. Set LAN Configuration.

Example:

Set LAN IP Address Source

IPMI Terminal: /> [30 00 01 01 04 01]

Byte5: "01" is static address (manually configured), "02" is DHCP.

It will respond [34 00 01 00]

Byte3: Completion code, "00" means received and admitted.

Set IP Address.

IPMI Terminal: /> [30 00 01 01 03 C0 A8 00 0A]

It will respond [34 00 01 00]

Byte3: Completion code "00" means received and admitted.

Set Subnet Mask.

IPMI Terminal: /> [30 00 01 01 06 FF FF FF 00]

It will respond [34 00 01 00]

Byte3: Completion code "00" means received and admitted.

Set Gateway Address.

IPMI Terminal: /> [30 00 01 01 0C C0 A8 00 01]

It will respond [34 00 01 00]

Byte3: Completion code "00" means received and admitted.

3.3 Expander Firmware Update via Expander Console Port

For the expander with firmware in the operational state, the default SDK code provides the CLI interface and supports the commands to download the manufacturing image. You must be connected to the smart CLI port for this. The smart CLI port uses the XMODEM protocol to push the binary manufacturing image into the Manufacturing region in Flash memory. It is effective after reset. Examples follow:

Step 1. Please type “fdl 0 0” in command line to update the firmware.



Step 2: Uses the XMODEM protocol to push the binary firmware image into the Manufacturing region in Flash memory.

Step 3: After completing the FW update, the screen will show “Buffer Download Complete”.

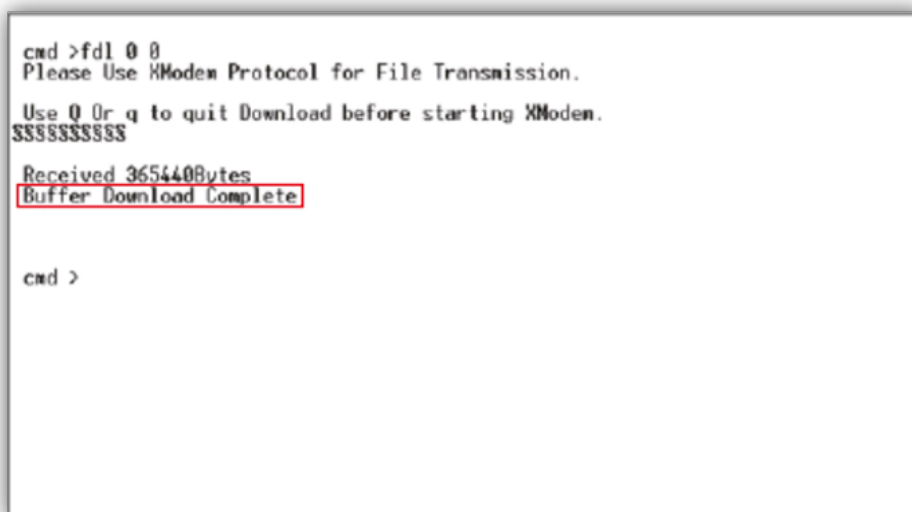

Step 4: Please type “fdl 83 0” in command line to update the MFG



Step 5: Uses the XMODEM protocol to push the binary MFG image into the Manufacturing region in Flash memory.

Step 6: After completing the MFG update, the screen will show “Buffer Download Complete”.

3.4 Expander Firmware Configuration

3.4.1 Configure Serial Command Line Interface

The RS232 setting - baud rate: 38400 bps, data bits: 8, parity: none, stop bits: 1, flow control: none

3.4.1.1 How to enable/disable T10 zoning

The default T10 zoning configuration is off.

(A) Check the current zoning state

```
cmd> phyzone state
Zoning is OFF
```

(B) Enable zoning

```
cmd> phyzone on
```

(C) Disable zoning

```
cmd> phyzone off
```

3.4.1 .2 How to configure T10 zoning

After enabling T10 zoning, five predefined groups are Group1, Group8, Group9, Group10, and Group11. Each PHY should be in one of the five groups, and all PHYs in a wide port should be in the same group. Each PHY in Group1 can access any PHY in other groups, and vice versa. Each PHY in Group8 cannot access any PHY in Group9, and vice versa.

The command syntax is "phyzone phy_index group". The following example shows how to setup one drive bay accessed only by the first wide port and another drive bay accessed only by the second wide port.

The configuration for the example is

(A) PHY0 ~ PHY3 for the first wide port

(B) PHY4 ~ PHY7 for the second wide port

(C) PHY12 ~ PHY35 for drive bays

Step 1: Read the current group for PHY4

```
cmd> phyzone 4
Phy 4 for Zone Group 1
```

Step 2: Assign the second wide port (PHY4 ~ PHY7) for Group9

```
cmd> phyzone 4 9
cmd> phyzone 5 9
cmd> phyzone 6 9
cmd> phyzone 7 9
```

Step 3: Assign the first wide port (PHY0 ~ PHY3) for Group8

```
cmd> phyzone 0 8
cmd> phyzone 1 8
cmd> phyzone 2 8
cmd> phyzone 3 8
```

Step 4: Assign the drive bay on PHY12 to be accessed only by the first wide port instead of the second wide port

```
cmd> phyzone 12 8
```

Step 5: Assign the drive bay on PHY13 to be accessed only by the second wide port instead of the first wide port

```
cmd> phyzone 13 9
```

Step 6: Reset for taking effect with the new settings

```
cmd> reset
```

3.4.1.3 How to get all revisions in AIC SAS 12G Expander

- (A) Expander firmware revision
cmd> rev
- (B) Expander configuration revision
cmd> showmfg
- (C) Model and sensor information
cmd> sensor

3.4.1.4 How to configure temperature sensor

There are 5 temperature sensors. Four temperature settings in Celsius per sensor are T1, T2, warning threshold, and alarm (critical) threshold. The T1 and T2 are applied to the auto fan function.

- (A) Get the current settings of Temperature Sensor 1
cmd> temperature 1
Temperature in Celsius (t1=20 C, t2=60 C, warning=57 C, alarm=60 C)
- (B) Set with new T1=18 C, T2=52 C, warning threshold=48 C, and alarm threshold=54 C.
The new setting will take effect after reset.
cmd> temperature 1 18 52 48 54
cmd> reset

3.4.1.5 How to configure enclosure address

- (A) Get the current enclosure address
cmd> enclosure_addr
Enclosure Address: 0x500605B0000272BF
- (B) Set the enclosure address with 0x500605B0000272BF. The new setting will take effect after reset.
cmd> enclosure_addr 500605B0000272BF
cmd> reset

3.4.1.6 How to configure standby timer for all disk drives

This feature is applicable for SAS/SATA drives. Standby timer is in units of minutes. Setting standby timer with 0 minute disables this feature.

- (A) Get current standby timer
cmd> standby_timer
Standby Timer : 0 minutes
- (B) Set the standby timer with 10 minutes. The new setting will take effect after reset.
cmd> standby_timer 10
cmd> reset

3.4.1.7 How to configure wide port checker

This feature is applicable for SAS drives instead of SATA drives. If there is no connection with any active SAS initiator by checking all wide ports, AIC Expander Controller stops all attached SAS drives to save power consumption of SAS drives. Otherwise, AIC Expander Controller starts all attached SAS drives to provide drive access service to any active SAS initiator.

(A) Get the current state of wide port checker

```
cmd> check_wide_port
Checking wide port is OFF
```

(B) Enable checking wide port. The new setting will take effect after reset.

```
cmd> check_wide_port on
cmd> reset
```

(C) Disable checking wide port. The new setting will take effect after reset.

```
cmd> check_wide_port off
cmd> reset
```

3.4.1.8 How to power off/on all disk drives automatically

This feature is applicable for SAS/SATA drives. If there is no connection with any active SAS initiator by checking all wide ports, AIC Expander Controller powers off all attached SAS/SATA drives to save power consumption. Otherwise, AIC Expander Controller powers on all attached SAS/SATA drives to provide drive access service to any active SAS initiator.

```
cmd> check_wide_port standby
cmd> reset
```

The function will not work properly when the drive bay power is turned off with SES command of clearing "RQST_ON" of the Power Supply Element "DiskPowerSupply".

The drive bay power will be turned on/off when SAS cable is connected/disconnected, even if the drive bay power is turned off/on by BMC or SES command of array device before SAS cable connected/disconnected.

3.4.1.9 How to configure EDFB

The default EDFB configuration is on.

(A) Check the current configuration

```
cmd> edfb
EDFB is OFF
```

(B) Enable EDFB

```
cmd> edfb on
```

(C) Disable EDFB

```
cmd> edfb off
```

3.4.2 SES Inband Features

To ensure proper function, high performance, and durability, JBOD has implemented SCSI Enclosure Services to monitor the status of power supply, system cooling fan, and working temperature. It also has indicators to deliver the status of fail devices such as power supply or cooling fan. You can get the information directly from the front indicators to know how your enclosure works.

For detailed information, please visit <http://www.t10.org>

If you are a member of the T10 working group, the Standard which controlled by T10 technical committee, could be found at

<http://www.t10.org/cgi-bin/ac.pl?t=f&f=ses2r19a.pdf>

3.4.2.1 SES Pages

00h - List of supported diagnostic pages

01h - SES configuration

02h - SES enclosure control / enclosure status

05h - SES Threshold Out / In

07h - SES element descriptor

0Ah - SES additional element

0Eh - SES download microcode control / SES download microcode status

82h - SES vendor specific page: Chassis Number

83h - SES vendor specific page: Canister Number

8Bh - SES vendor specific page: Drive Bay Blue LED

3.4.2.2 SES Elements

02h - Power Supply

03h - Cooling

04h - Temperature Sensor

0Eh - Enclosure

12h - Voltage

17h - Array Device

3.4.2.3 Implementation on SES Pages

SES Threshold Out / In

It includes only Temperature Sensor and Voltage Sensor elements.

Threshold control element format

BYTE/BIT	7	6	5	4	3	2	1	0
0	REQUESTED HIGH CRITICAL THRESHOLD							
1	REQUESTED HIGH WARNING THRESHOLD							
2	REQUESTED LOW WARNING THRESHOLD							
3	REQUESTED LOW CRITICAL THRESHOLD							

Threshold status element format

BYTE/BIT	7	6	5	4	3	2	1	0
0	HIGH CRITICAL THRESHOLD							
1	HIGH WARNING THRESHOLD							
2	LOW WARNING THRESHOLD							
3	LOW CRITICAL THRESHOLD							

3.4.3 SES vendor specific page: Chassis Number (page code 82h) Out / In

The length N of chassis number can be 0 ~ 30 bytes. If no chassis number is input (N=0), then chassis number is cleared.

3.4.3.1 Chassis Number control format

BYTE/BIT	7	6	5	4	3	2	1	0
0~N	Canister Number							

If no chassis number is found, report Status = 1 (failed). Otherwise report Status = 0 (success) followed by chassis number.

3.4.3.2 Chassis Number status format

BYTE/BIT	7	6	5	4	3	2	1	0
0	Status (0: success, 1: failed)							
1~N (if success)	Canister Number							

3.4.4 SES vendor specific page: Canister Number (page code 83h) Out / In

The length N of canister number can be 0 ~ 30 bytes. If no canister number is input (N=0), then canister number is restored to default: 0x20 0x20 0x20 0x20 0x20 0x20 0x20 0x20 (8 spaces in ASCII).

3.4.4.1 Canister Number control format

BYTE/BIT	7	6	5	4	3	2	1	0
0~N	Canister Number							

If no canister number is found, report Status = 1 (failed). Otherwise report Status = 0 (success) followed by canister number.

3.4.4.2 Canister Number status format

BYTE/BIT	7	6	5	4	3	2	1	0
0	Status (0: success, 1: failed)							
1~N (if success)	Canister Number							

3.4.5 SES vendor specific page: Drive Bay Blue LED (page code 8Bh) Out / In

The drive bay blue LED can be enabled/disabled through the control format:

3.4.5.1 Drive Bay Blue LED control format

BYTE/BIT	7	6	5	4	3	2	1	0
0	Drive Bay ID in hexadecimal							
1	0x00 to disable the blue LED, and 0x1 to enable the blue LED							

The reported length of the drive bay blue LED status format depends on the number of the drive bays. The report represents the statuses of all drive bays. The status of the drive bay is either 0x00 or 0x01. The status "0x00" means that the drive bay blue LED is disabled, and the status "0x01" means the drive bay blue LED is enabled.

3.5 Implementation on SES Elements

Only the fields highlighted in blue are supported.

3.5.1 Power Supply Element

3.5.1.1 Power Supply Control Element

BYTE/BIT	7	6	5	4	3	2	1	0
0	COMMON CONTROL							
	SELECT	PRDFAIL	DISABLE	RST SWAP	Reserved			
1	RQST IDENT	Reserved						
2	Reserved							
3	Reserved	RQST FAIL	RQST ON	Reserved				

Field	Value
RQST ON	Please refer to section "SES Element Control Functions" for details.

3.5.1.2 Power Supply Status Element

BYTE/BIT	7	6	5	4	3	2	1	0	
0	COMMON STATUS								
	Reserved	PRDFAIL	DISABLED	SWAP	ELEMENT STATUS CODE				
1	IDENT	Reserved							
2	Reserved				DC OVER VOLTAGE	DC UNDER VOLTAGE	DC OVER CURRENT	Reserved	
3	HOT SWAP	FAIL	RQST ON	OFF	OVERTMP FAIL	TEMP WARN	AC FAIL	DC FAIL	

Field	Value
ELEMENT STATUS CODE	OK: No failure or warning conditions detected CRITICAL: FAIL bit is set due to one or more failure condition UNKNOWN: The power supply can't be read
FAIL	A failure condition is detected
RQSTED ON	1: On 0: Off for Disk Power Supply
OFF	1: Off for Disk Power Supply 0: On
AC FAIL	A failure condition is detected
DC FAIL	A failure condition is detected

3.5.2 Cooling Element

3.5.2.1 Cooling Control Element

BYTE/BIT	7	6	5	4	3	2	1	0
0	COMMON CONTROL							
	SELECT	PRDFAIL	DISABLE	RST SWAP	Reserved			
1	RQST IDENT	Reserved						
2	Reserved							
3	Reserved	RQST FAIL	RQST ON	Reserved		REQUESTED SPEED CODE		

Field	Value
RQST IDENT	Please refer to section "SES Element Control Functions" for details.
REQUESTED SPEED CODE	Please refer to section "SES Element Control Functions" for details.

3.5.2.2 Cooling Status Element

BYTE/BIT	7	6	5	4	3	2	1	0
0	COMMON STATUS							
	Reserved	PRDFAIL	DISABLED	SWAP	ELEMENT STATUS CODE			
1	IDENT	Reserved				ACTUAL FAN SPEED (MSB)		
2	ACTUAL FAN SPEED (LSB)							
3	HOT SWAP	FAIL	RQST ON	OFF	Reserved	ACTUAL SPEED CODE		

Field	Value
ELEMENT STATUS CODE	OK: Everything is Ok. NON-CRITICAL: Either warning limit is exceeded. CRITICAL: The fan RPM can't be detected, or either failure limit is exceeded.
IDENT	Applicable only for Cooling element 0 0: Enable the auto fan function 1: Disable the auto fan function
ACTUAL FAN SPEED	Current fan RPM
FAIL	The fan RPM can't be detected, or either failure limit is exceeded.
ACTUAL SPEED CODE	Speed code level bases on current fan RPM.

3.5.2.3 Fan Location

Rear Panel

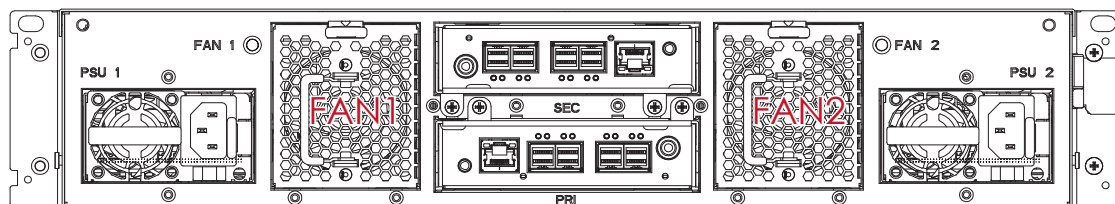

3.5.3 Temperature Sensor Element

3.5.3.1 Temperature Sensor Control Element

BYTE/BIT	7	6	5	4	3	2	1	0
0	COMMON CONTROL							
	SELECT	PRDFAIL	DISABLE	RST SWAP	Reserved			
1	RQST IDENT	RQST FAIL	Reserved					
2	Reserved							
3	Reserved							

3.5.3.2 Temperature Sensor Status Element

BYTE/BIT	7	6	5	4	3	2	1	0
0	COMMON STATUS							
	Reserved	PRDFAIL	DISABLED	SWAP	ELEMENT STATUS CODE			
1	IDENT	FAIL	Reserved					
2	TEMPERATURE							
3	Reserved				OT FAILURE	OT WARNING	UT FAILURE	UT WARNING

Field	Value
ELEMENT STATUS CODE	OK: Everything is Ok NON-CRITICAL: Either warning limit is exceeded CRITICAL: Either failure limit is exceeded
FAIL	A warning or failure condition is detected
TEMPERATURE	Temperature reading
OT FAILURE	Temperature exceeds the failure high threshold value
OT WARNING	Temperature exceeds the warning high threshold value
UT FAILURE	Temperature is below the failure low threshold value
UT FAILURE	Temperature is below the warning low threshold value

3.5.3.3 Temperature Sensor Location

Drive Backplane Top View

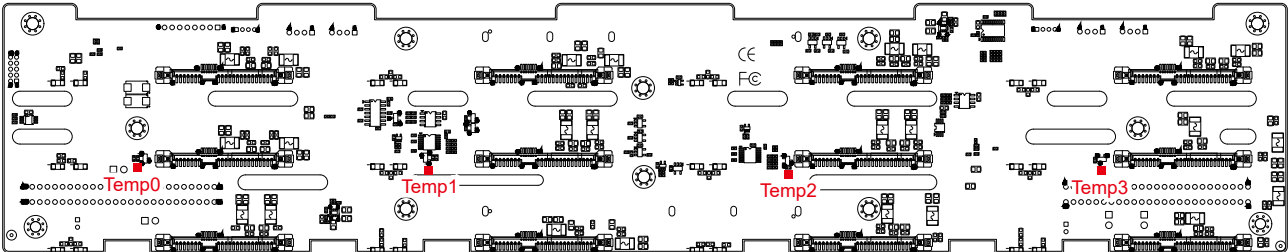

Drive Backplane Bottom View

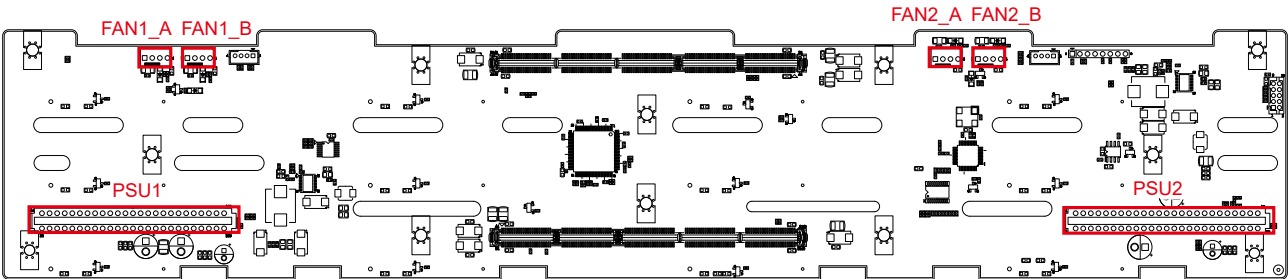

3.5.4 Enclosure Element

3.5.4.1 Enclosure Control Element

BYTE/BIT	7	6	5	4	3	2	1	0
0	COMMON CONTROL							
	SELECT	PRDFAIL	DISABLE	RST SWAP	Reserved			
1	RQST IDENT	Reserved						
2	POWER CYCLE REQUEST		POWER CYCLE DELAY					
3	POWER OFF DURATION						REQUEST FAILURE REQUEST	REQUEST WARNING

Field	Value
REQUEST FAILURE	Please refer to section "SES Element Control Functions" for details.
REQUEST WARNING	Please refer to section "SES Element Control Functions" for details.

3.5.4.2 Enclosure Status Element

BYTE/BIT	7	6	5	4	3	2	1	0
0	COMMON STATUS							
	Reserved	PRDFAIL	DISABLED	SWAP	ELEMENT STATUS CODE			
1	IDENT	Reserved						
2	TIME UNTIL POWER CYCLE						FAILURE INDICATION	WARNING INDICATION
3	REQUEST POWER OFF DURATION						FAILURE REQUESTED	WARNING REQUESTED

Field	Value
ELEMENT STATUS CODE	OK
FAILURE REQUESTED	Set by the REQUEST FAILURE on Enclosure Control Element
WARNING REQUESTED	Set by the REQUEST WARNING on Enclosure Control Element

3.5.5 Voltage Element

3.5.5.1 Voltage Control Element

BYTE/BIT	7	6	5	4	3	2	1	0
0	COMMON CONTROL							
	SELECT	PRDFAIL	DISABLE	RST SWAP	Reserved			
1	RQST IDENT	RQST FAIL	Reserved					
2	Reserved							
3	Reserved							

3.5.5.2 Voltage Status Element

BYTE/BIT	7	6	5	4	3	2	1	0
0	COMMON STATUS							
	Reserved	PRDFAIL	DISABLED	SWAP	ELEMENT STATUS CODE			
1	IDENT	FAIL	Reserved		WARN OVER	WARN UNDER	CRIT OVER	CRIT UNDER
2	VOLTAGE							
3								

Field	Value
ELEMENT STATUS CODE	OK: Everything is Ok NON-CRITICAL: Either warning limit is exceeded CRITICAL: Either failure limit is exceeded
FAIL	A warning or failure condition is detected
WARN OVER	Voltage exceeds the warning high threshold value
WARN UNDER	Voltage is below the warning low threshold value
CRIT OVER	Voltage exceeds the failure high threshold value
CRIT UNDER	Voltage is below the failure low threshold value
VOLTAGE	Voltage reading

3.5.6 Array Device Element

3.5.6.1 Array Device Control Element

BYTE/BIT	7	6	5	4	3	2	1	0
0	COMMON CONTROL							
	SELECT	PRDFAIL	DISABLE	RST SWAP	Reserved			
1	RQST OK	RQST RSVD DEVICE	RQST HOT SPARE	RQST CONS CHECK	RQST IN CRIT ARRAY	RQST IN FAILED ARRAY	RQST REBUILD/REMAP	RQST R/R ABORT
2	RQST ACTIVE	DO NOT REMOVE	Reserved	RQST MISSING	RQST INSERT	RQST REMOVE	RQST IDENT	Reserved
3	Reserved		RQST FAULT	DEVICE OFF	ENABLE BYP A	ENABLE BYP B	Reserved	

Field	Value
PRDFAIL	Please refer to section "SES Element Control Functions" for details.
RQST OK	Please refer to section "SES Element Control Functions" for details.
RQST RSVD DEVICE	Please refer to section "SES Element Control Functions" for details.
RQST HOT SPARE	Please refer to section "SES Element Control Functions" for details.
RQST CONS CHECK	Please refer to section "SES Element Control Functions" for details.
RQST IN CRIT ARRAY	Please refer to section "SES Element Control Functions" for details.
RQST IN FAILED ARRAY	Please refer to section "SES Element Control Functions" for details.
RQST REBUILD/REMAP	Please refer to section "SES Element Control Functions" for details.
RQST R/R ABORT	Please refer to section "SES Element Control Functions" for details.
RQST ACTIVE	Please refer to section "SES Element Control Functions" for details.
DO NOT REMOVE	Please refer to section "SES Element Control Functions" for details.
RQST MISSING	Please refer to section "SES Element Control Functions" for details.
RQST INSERT	Please refer to section "SES Element Control Functions" for details.
RQST REMOVE	Please refer to section "SES Element Control Functions" for details.
RQST IDENT	Please refer to section "SES Element Control Functions" for details.
RQST FAULT	Please refer to section "SES Element Control Functions" for details.
DEVICE OFF	Please refer to section "SES Element Control Functions" for details.

3.5.6.2 Array Device Status Element

BYTE/BIT	7	6	5	4	3	2	1	0
0	COMMON STATUS							
	Reserved	PRDFAIL	DISABLED	SWAP	ELEMENT STATUS CODE			
1	OK	RSVD DEVICE	HOT SPARE	CONS CHK	IN CRIT ARRAY	IN FAILED ARRAY	REBUILD/REMAP	R/R ABORT
2	APP CLIENT BYPASSED A	DO NOT REMOVE	ENCLOSURE BYPASSED A	ENCLOSURE BYPASSED B	READY TO INSERT	RMV	IDENT	REPORT
3	APP CLIENT BYPASSED B	FAULT SENSED	FAULT REQSTD	DEVICE OFF	BYPASSED A	BYPASSED B	DEVICE BYPASSED A	DEVICE BYPASSED B

Field	Value
PRDFAIL	Set by the PRDFAIL on Array Device Control Element
ELEMENT STATUS CODE	OK: A drive is detected in the drive bay NOT INSTALLED: No drive is installed in the drive bay
OK	Set by the RQST OK on Array Device Control Element
RSVD DEVICE	Set by the RQST RSVD DEVICE on Array Device Control Element
HOT SPARE	Set by the RQST HOT SPARE on Array Device Control Element
CONS CHK	Set by the RQST CONS CHECK on Array Device Control Element
IN CRIT ARRAY	Set by the RQST IN CRIT ARRAY on Array Device Control Element
IN FAILED ARRAY	Set by the RQST IN FAILED ARRAY on Array Device Control Element
REBUILD/REMAP	Set by the RQST REBUILD/REMAP on Array Device Control Element
R/R ABORT	Set by the RQST R/R ABORT on Array Device Control Element
DO NOT REMOVE	Set by the DO NOT REMOVE on Array Device Control Element
READY TO INSERT	Set by the RQST INSERT on Array Device Control Element
RMV	Set by the RQST REMOVE on Array Device Control Element
IDENT	Set by the RQST IDENT on Array Device Control Element
FAULT REQSTD	Set by the RQST FAULT on Array Device Control Element
DEVICE OFF	Set by the DEVICE OFF on Array Device Control Element

3.6 SES Element Control Functions

3.6.1 LED indicators (blue and red) associated with an attached disk drive

3.6.1.1 Array Device Slot control element

BYTE/BIT	7	6	5	4	3	2	1	0
0	COMMON CONTROL							
	SELECT	PRDFAIL	DISABLE	RST SWAP	Reserved			
1	RQST OK	RQST RSVD DEVICE	RQST HOT SPARE	RQST CONS CHECK	RQST IN CRIT ARRAY	RQST IN FAILED ARRAY	RQST REBUILD/REMAP	RQST R/R ABORT
2	RQST ACTIVE	DO NOT REMOVE	Reserved	RQST MISSING	RQST INSERT	RQST REMOVE	RQST IDENT	Reserved
3	Reserved		RQST FAULT	DEVICE OFF	ENABLE BYP A	ENABLE BYP B	Reserved	

The default behavior for blue LED is "LED is on when the disk is not busy, and off when the disk is executing a command". When the "RQST IDENT" bit is set, the blue LED overwrites its default behavior with a slow blink while the red LED is off. The blue LED is set "Activity" for not overwriting its default behavior.

The behavior "Fast Blink" is "LED is blinking at 8Hz frequency".

The behavior "Slow Blink" is "LED is blinking at 1Hz frequency".

The behavior "ON"/"OFF" is "LED is solid ON/OFF without blinking".

Slot Control Bit	Blue LED	Red LED
RQST OK	Activity	OFF
RQST RSVD DEVICE	Activity	OFF
RQST HOT SPARE	Activity	OFF
RQST CONS CHECK	Activity	Fast Blink
RQST IN CRIT ARRAY	Activity	Slow Blink
RQST IN FAILED ARRAY	Activity	Slow Blink
RQST REBUILD/REMAP	Activity	Fast Blink
RQST R/R ABORT	Activity	Slow Blink
RQST ACTIVE	Activity	OFF
DO NOT REMOVE	Activity	OFF
RQST MISSING	ON	ON
RQST INSERT	Activity	Slow Blink
RQST REMOVE	Activity	Slow Blink
RQST IDENT	Slow Blink	OFF
RQST FAULT	ON	ON
DEVICE OFF	OFF	OFF
PRDFAIL	Activity	Slow Blink

3.6.2 How to turn on/off the power of a drive bay

3.6.2.1 Array Device Slot control element

BYTE/BIT	7	6	5	4	3	2	1	0
0	COMMON CONTROL							
	SELECT	PRDFAIL	DISABLE	RST SWAP	Reserved			
1	RQST OK	RQST RSVD DEVICE	RQST HOT SPARE	RQST CONS CHECK	RQST IN CRIT ARRAY	RQST IN FAILED ARRAY	RQST REBUILD/REMAP	RQST R/R ABORT
2	RQST ACTIVE	DO NOT REMOVE	Reserved	RQST MISSING	RQST INSERT	RQST REMOVE	RQST IDENT	Reserved
3	Reserved		RQST FAULT	DEVICE OFF	ENABLE BYP A	ENABLE BYP B	Reserved	

The "DEVICE OFF" for a drive bay is defined in the bit4, byte3 of the "Array Device Slot control element" in the SES specification. Set the bit to turn off a drive bay power, and vice versa. We use the software package "sg3_utils" on Linux for example, and have a SAS HBA and a cable to connect your host with the expander.

(A) Show the device for AIC Expander Controller (canister)

```
$ sg_map -i
/dev/sg2 AIC 12G Hotswap Expander 0c01
```

(B) Get the current power state of a drive bay. The "Device off=0" means the drive bay power is on.

```
$ sg_ses --page=2 /dev/sg2
Element 0 descriptor:
App client bypass B=0, Fault sensed=0, Fault reqstd=0, Device off=0
```

(C) Get the descriptor of a drive bay

```
$ sg_ses --page=7 /dev/sg2
Element 0 descriptor: Disk001
```

(D) Turn off a drive bay power

```
$ sg_ses --descriptor=Disk001 --set=3:4:1 /dev/sg2
```

(E) Turn on a drive bay power

```
$ sg_ses --descriptor=Disk001 --clear=3:4:1 /dev/sg2
```

3.6.3 How to power off/on all drive bays manually

3.6.3.1 Power Supply control element

BYTE/BIT	7	6	5	4	3	2	1	0
0	COMMON CONTROL							
	SELECT	PRDFAIL	DISABLE	RST SWAP	Reserved			
1	RQST IDENT	Reserved						
2	Reserved							
3	Reserved	RQST FAULT	RQST ON	Reserved				

The "RQST ON" for Power Supply is defined in the bit5, byte3 of the "Power Supply control element" in the SES specification. Clear the bit on Power Supply Element "DiskPowerSupply" to power off all drive bays. Set the bit on Power Supply Element "DiskPowerSupply" to power on all drive bays. We use the software package "sg3_utils" on Linux for example, and have a SAS HBA and a cable to connect your host with the expander.

(A) Show the device for AIC Expander Controller (canister)

```
$ sg_map -i
dev/sg2 AIC 12G Hotswap Expander 0c01
```

(B) Power off all drive bays

```
$ sg_ses --descriptor=DiskPowerSupply --clear=3:5:1 /dev/sg2
```

(C) Power on all drive bays

```
$ sg_ses --descriptor=DiskPowerSupply --set=3:5:1 /dev/sg2
```

3.6.4 How to enable/disable the enclosure alarm by your software

3.6.4.1 Enclosure control element

BYTE/BIT	7	6	5	4	3	2	1	0
0	COMMON CONTROL							
	SELECT	PRDFAIL	DISABLE	RST SWAP	Reserved			
1	RQST IDENT	Reserved						
2	POWER CYCLE REQUEST		POWER CYCLE DELAY					
3	POWER OFF DURATION						REQUEST FAILURE	REQUEST WARNING

The system alarm LED is used for the enclosure alarm and power alarm. The "REQUEST FAILURE" and "REQUEST WARNING" for Enclosure are defined in the bit1, byte3 and bit0, byte3 of the "Enclosure control element" in the SES specification. Setting either bit can enable the enclosure alarm. Clearing both bits disables the enclosure alarm. We use the software package "sg3_utils" on Linux for example, and have a SAS HBA and a cable to connect your host with the expander.

(A) Show the device for AIC Expander Controller (canister)

```
$ sg_map -i
/dev/sg2 AIC 12G Hotswap Expander 0c01
```

(B) Enable the enclosure alarm

```
$ sg_ses --descriptor=EnclosureElement --set=3:1:1 /dev/sg2
```

or

```
$ sg_ses --descriptor=EnclosureElement --set=3:0:1 /dev/sg2
```

(C) Disable the enclosure alarm

```
$ sg_ses --descriptor=EnclosureElement --clear=3:1:2 /dev/sg2
```

3.6.5 How to manually change PWM (fan speed) for all Cooling elements

3.6.5.1 Cooling control element

BYTE/BIT	7	6	5	4	3	2	1	0
0	COMMON CONTROL							
	SELECT	PRDFAIL	DISABLE	RST SWAP	Reserved			
1	RQST IDENT	Reserved						
2	Reserved							
3	Reserved	RQST FAULT	RQST ON	Reserved	REQUESTED SPEED CODE			

The "RQST IDENT" for Cooling is defined in the bit7, byte1 and the "REQUESTED SPEED CODE" is defined in the bit2 ~ 0, byte3 of the "Cooling control element" in the SES specification. Set "RQST IDENT" bit to disable the auto fan function, and then change PWM or fan speed for all Cooling elements by setting the "REQUESTED SPEED CODE" bits. Clear "RQST IDENT" bit to enable the auto fan function again. Please disable the auto fan function before changing PWM or fan speed. Only Cooling element 0 supports this feature. We use the software package "sg3_utils" on Linux for example, and have a SAS HBA and a cable to connect your host with the expander.

(A) Show the device for AIC Expander Controller (canister)

```
$ sg_map -i
/dev/sg2 AIC 12G Hotswap Expander 0c01
```

(B) Set "RQST IDENT" of Cooling element 0 to disable the auto fan function

```
$ sg_ses --descriptor=CoolingElement00 --set=1:7:1 /dev/sg2
```

(C) Set "REQUESTED SPEED CODE" of Cooling element 0 to change PWM or fan speed for all Cooling elements. Set "REQUESTED SPEED CODE"=7 (100% PWM) for example.

```
$ sg_ses --descriptor=CoolingElement00 --set 3:2:3=7 /dev/sg2
```

REQUESTED SPEED CODE	PWM
7	100%
6	90%
5	80%
4	70%
3	60%
2	50%
1	40%
0	Leave at current speed

3.7 Vendor Specific Vital Product Data (VPD) Page

The Vendor Specific VPD pages provide MFR_ID, MFR_MODEL, MFR_REVISION, MFR_SERIAL, and MFR_FW_REVISION of the power module 0 (page code 0xC1) and power module 1 (page code 0xC2).

Vendor Specific VPD Page Format

BYTE/BIT	7	6	5	4	3	2	1	0
1	MFR_ID							
m								
m+1	0x20 (ASCII code space)							
m+2	MFR_MODEL							
n								
n+1	0x20 (ASCII code space)							
n+2	MFR_REVISION							
o								
o+1	0x20 (ASCII code space)							
o+2	MFR_SERIAL							
p								
p+1	0x20 (ASCII code space)							
p+2	MFR_FW_REVISION							
q								
q+1	0x20 (ASCII code space)							

Chapter 4. Technical Support



www.aicipc.com

Taiwan, Global Headquarters

Address: No. 152, Section 4,
Linghang N. Rd, Dayuan District,
Taoyuan City 337, Taiwan
Tel: +886-3-433-9188
Fax: +886-3-287-1818
Sales Email: sales@aicipc.com.tw
Support Email: support@aicipc.com

Shanghai, China

Address: Room 215, Building 4, No.471
Guiping Road, Xuhui District, Shanghai City,
200233 China
Tel: +86-21-54961421
Sales Email: sales@aicipc.com.cn
Support Email: support@aicipc.com

Moscow, Russia

Address: No. 500, 5th Floor, 5th Entrance,
32A, Khoroshevskoye Shosse, Moscow,
123007
Tel: +7-4997019998
Sales Email: support-ru@aicipc.com.tw
Support Email: rma.russia@aicipc.com.tw

North California, United States

Address: 48531 Warm Springs
Boulevard Suite 404 Fremont, CA
94539, United States
Tel: +1-510-573-6730
Sales Email: sales@aicipc.com
Support Email: support@aicipc.com

South California, United States

Address: 21808 Garcia Lane
City of Industry, CA 91789,
United States
Toll free: + 1-866-800-0056
Tel: +1-909-895-8989
Fax: +1-909-895-8999
Sales Email: sales@aicipc.com
Support Email: support@aicipc.com

New Jersey, United States

Address: 322 Route 46 West Suite 100
Parsippany, NJ 07054 United States
Tel: +1-973-884-8886
Fax: +1-973-884-4794
Sales Email: sales@aicipc.com
Support Email: support@aicipc.com

Houten, The Netherlands

Address: Peppelkade 58, 3992AK, Houten,
The Netherlands
Tel: +31-30-6386789
Fax: +31-30-6360638
Sales Email: sales@aicipc.nl
Support Email: support@aicipc.com

For additional technical support or questions about trouble shooting, please contact the AIC® representative nearest to you or visit our AIC® website for more information.
AIC® website: <https://www.aicipc.com/en/faq>.