



康舒科技

ACBEL POLYTECH INC.

Safety



Ref. Certif. No.

JPTUV-146309

IEC SYSTEM FOR MUTUAL RECOGNITION OF TEST CERTIFICATES FOR ELECTRICAL EQUIPMENT
(IECEE) CB SCHEME**CB TEST CERTIFICATE**

Product	Switching Power Supply
Name and address of the applicant	Acbel Polytech Inc. No. 159, Sec. 3, Danjin Rd., Tamsui Dist., New Taipei City 251 Taiwan
Name and address of the manufacturer	Acbel Polytech Inc. No. 159, Sec. 3, Danjin Rd., Tamsui Dist., New Taipei City 251 Taiwan
Name and address of the factory	See additional page(s)
Ratings and principal characteristics	Input : 1) AC 100-127V; 50/60Hz; 10.0A, 2) AC 200-240V; 50/60Hz; 8.0A or DC 240V; 6A MAX; Class I Output: refer to the test report
Trademark (if any)	AcBel
Customer's Testing Facility (CTF) Stage used	CTF Stage 1
Model / Type Ref.	FSF050, R1CA2122A
Additional information (if necessary may also be reported on page 2)	For model differences, refer to the test report.
A sample of the product was tested and found to be in conformity with	IEC 62368-1:2018 See Test Report for National Differences
As shown in the Test Report Ref. No. which forms part of this Certificate	CN23BW57 001

This CB Test Certificate is issued by the National Certification Body

TÜV Rheinland Japan Ltd.
Global Technology Assessment Center
4-25-2 Kita-Yamata, Tsuzuki-ku
Yokohama 224-0021, Japan
Phone + 81 45 914-3888
Fax + 81 45 914-3354
Mail: info@jpn.tuv.com
Web : www.tuv.com

Date: 2023-03-29

Signature:

Dipl.-Ing. Th. Illing

1. Acbel Polytech Philippines Inc.
#2 Tagaytay Ridge Drive, Carmelray Industrial Park 2,
Km.54 National Highway, Calamba City,
Laguna 4027
Philippines
2. ACBEL ELECTRONIC (WUHAN) CO., LTD
No. 1, DuTai North Road
Economic Development Zone
XianTao City, HuBei Province
P.R. China
3. Acbel Electronic (Dong Guan)
Co., Ltd.
No. 17-28, Horng Yeh Road, Horng
Yeh Ind. District, Tang Xia Town
Dongguan, Guangdong 523710, P.R. China
4. Acbel Polytech Inc.
No. 159,
Sec. 3, Danjin Rd., Tamsui Dist.,
New Taipei City 251
Taiwan

Additional information (if necessary)

Report Ref. No. : CN23BW57 001

Date: 2023-03-29

Signature:

Dipl.-Ing. Th. Illing





Ref. Certif. No.

JPTUV-094570

IEC SYSTEM FOR MUTUAL RECOGNITION OF TEST CERTIFICATES FOR ELECTRICAL EQUIPMENT (IECEE) CB SCHEME

SYSTEME CEI D'ACCEPTATION MUTUELLE DE CERTIFICATS D ESSAIS DES EQUIPEMENTS ELECTRIQUES (IECEE) METHODE OC

CB TEST CERTIFICATE

CERTIFICAT D'ESSAI OC

Product
Produit

Switching Power Supply

Name and address of the applicant
Nom et adresse du demandeur

Acbel Polytech Inc.
No. 159, Sec. 3, Danjin Rd.,
Tamsui Dist., New Taipei City 251 Taiwan

Name and address of the manufacturer
Nom et adresse du fabricant

Acbel Polytech Inc.
No. 159, Sec. 3, Danjin Rd.,
Tamsui Dist., New Taipei City 251 Taiwan

Name and address of the factory
Nom et adresse de l'usine

See additional page(s)

Ratings and principal characteristics
Valeurs nominales et caractéristiques principales

Input : 1) AC 100-127V; 50/60Hz; 10.0A,
2) AC 200-240V; 50/60Hz; 8.0A or DC 240V; 6A MAX;
Class I

Output: refer to the test report

Trademark (if any)
Marque de fabrique (si elle existe)

AcBel

Type of Manufacturer's Testing Laboratories used
Type de programme du laboratoire d'essais constructeur

CTF Stage 1

Model / Type Ref.
Ref. de type

FSF050, R1CA2122A

Additional information (if necessary may also be reported on page 2)
Les informations complémentaires (si nécessaire, peuvent être indiqués sur la 2^{ème} page)

For model differences, refer to the test report.

A sample of the product was tested and found to be in conformity with
Un échantillon de ce produit a été essayé et a été considéré conforme à la

IEC 62368-1:2014
See Test Report for National Differences

As shown in the Test Report Ref. No. which forms part of this Certificate
Comme indiqué dans le Rapport d'essais numéro de référence qui constitue partie de ce Certificat

50224610 001

This CB Test Certificate is issued by the National Certification Body
Ce Certificat d'essai OC est établi par l'Organisme National de Certification



TÜV Rheinland Japan Ltd.
Global Technology Assessment Center
4-25-2 Kita-Yamata, Tsuzuki-ku
Yokohama 224-0021 Japan
Phone + 81 45 914-3888
Fax + 81 45 914-3354
Mail: info@jpn.tuv.com
Web: www.tuv.com

Signature:

Dipl.-Ing. F. Stoelzel

Date: 21.02.2019

1. Acbel Electronic (Dong Guan)
Co., Ltd.
No. 17-28, Horng Yeh Road, Horng
Yeh Ind. District, Tang Xia Town
Dongguan, Guangdong 523710, P. R. China
2. Acbel Polytech Inc.
No. 159, Sec. 3, Danjin Rd.,
Tamsui Dist., New Taipei City 251
Taiwan
3. AcTel Electronic (Dong Guan) Co., Ltd.
No. 13-16, Hong Yeh 11Rd.
Hong Yeh Industrial District
Tang Xia Town Dong Guan City,
Guang Dong, P. R. China
4. ACBEL ELECTRONIC (WUHAN) CO., LTD
No. 1, DuTai North Road
Economic Development Zone
XianTao City, HuBei Province
P. R. China
5. Acbel Polytech(Philippines) INC.
No. 2 Tagaytay Ridge Drive,
Carmelray Industrial Park II,
Km. 54 National Highway,
Calamba City, Laguna 4027, Philippines

Additional information (if necessary)
Information complémentaire (si nécessaire)

Report Ref. No.: 50224610 001

Date: 21.02.2019

Signature:

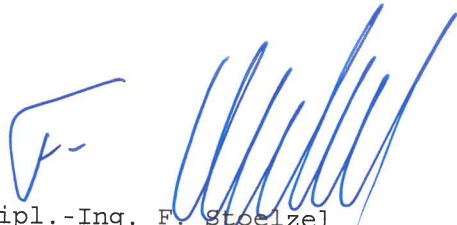
Dipl.-Ing. F. Stoelzel

Certificate No. R 50430418 Report No. 50226674 001 Appendix No. 1

Constructional Data Form (CDF) for Electrical Appliances

Page 1 of 35

License holder : Acbel Polytech Inc.
 No. 159, Sec. 3, Danjin Rd., Tamsui Dist., New Taipei City 251, Taiwan

Factory : 1. Acbel Polytech Inc.
 No. 159, Sec. 3, Danjin Rd., Tamsui Dist., New Taipei City 251, Taiwan

2. Acbel Electronic (Dong Guan) Co., Ltd.
 No. 17-28, Horng Yeh Road, Horng Yeh Ind. District, Tang Xia Town, Dongguan, Guangdong 523710, P.R. China

3. AcTel Electronic (Dong Guan) Co., Ltd.
 No. 13-16, Hong Yeh 11Rd., Hong Yeh Industrial District, Tang Xia Town, Dong Guan City, Guang Dong, P.R. China

4. ACBEL ELECTRONIC (WUHAN) CO., LTD
 No.1, DuTai North Road, Economic Development Zone, XianTao City, HuBei Province, P.R. China

5. Acbel Polytech (Philippines) INC.
 No. 2 Tagaytay Ridge Drive, Carmelray Industrial Park II, Km. 54 National Highway, Calamba City, Laguna 4027, Philippines

Type of Appliance : Switching Power Supply

Type Designation : FSF050, R1CA2122A (Acbel)

Rating : I/P: 1). 100-127V~, 50/60Hz, 10.0A
 2). 200-240V~, 50/60Hz, 8.0A or DC 240V, 6A MAX

O/P: 1). DC +12.0V/66.7A, +12Vsb/3.0A
 TOTAL POWER 800W MAX.
 2). DC +12.0V/100A, +12Vsb/3.0A
 TOTAL POWER 1200W MAX.

Protection Class : Class I

Supply connection : appliance coupler

Additional information :

Max. operation altitude: 5,000m

Weight: 0.823kg

Max. operation ambient: +50°C

Table A:

Model	Input Voltage	Rated Output Voltage (V)	Rated Output Current(mA)	Rated Output (VA)		
--	--	--	--	--		
--	--	--	--	--		

Constructional Data Form (CDF) for Electrical Appliances

Table B:

Critical Components

Material: e.g. external enclosure, closed-end connector, sleeves, cord anchorage etc

Components with winding: e.g. motor, transformer, magnetic coil etc.

Other components: e.g. switch, thermostat, heater, plug, internal wire, capacitor, relay, varistor etc.

Object/part No.	Manufacturer/ trademark	Type/ model	Technical data	Standard	Mark(s) of conformity
Inlet	Tecx-Unions Technology Corp.	TU-301 series (- A/AP/AP- A/S/SP)	10A, 250Vac; 15A, 125Vac for UL 10A, 250Vac/15A, 125Vac for BSMI 10A, 250Vdc (TÜV)	IEC 60320-1, UL 498, CSA C22.2 NO. 182.3, EN 60320- 1:2001+A1:20 07, GB17465.1- 2009	UL, CSA, ENEC(15), CCC
	Inalways Corp (International All Ways Ind Co Ltd)	0711 series	10A, 250Vac; 15A, 250Vac for UL 10A, 250Vdc (TÜV) 3.5A, 360Vdc (TÜV)	IEC 60320-1, UL 498, CSA C22.2 NO. 182.3, EN 60320- 1:2001+A1:20 07, GB17465.1- 2009	UL, CSA, VDE,CCC, ENEC
	Rong Feng Industrial Co Ltd	SS-120	10A, 250Vac; 15A, 250Vac for UL 10A, 250Vdc (TÜV)	IEC 60320- 1:2001+A1:20 07, UL 498, CSA C22.2 NO. 182.3, GB17465.1- 2009	UL, CSA, VDE,CCC
	SHENG MING ENTERPRISE CO LTD (WINTRON ENTERPRISE CO LTD)	S14-102	10A, 250Vac; 15A, 250Vac for UL/CUL; 10A, 250Vdc for TÜV	UL 498, CSA C22.2 NO. 182.3, IEC 60320-1, EN 60320- 1:2001+A1:20 07, GB17465.1- 2009	UL, CUL VDE,CCC

Constructional Data Form (CDF) for Electrical Appliances

Table B:

Critical Components

Material: e.g. external enclosure, closed-end connector, sleeves, cord anchorage etc

Components with winding: e.g. motor, transformer, magnetic coil etc.

Other components: e.g. switch, thermostat, heater, plug, internal wire, capacitor, relay, varistor etc.

Object/part No.	Manufacturer/ trademark	Type/ model	Technical data	Standard	Mark(s) of conformity
Fuse (F1)	Walter Electronic Co., Ltd.	FSC	F 15A, 250V	IEC 60127-1, IEC 60127-2, UL 248-14, CSA C22.2 NO. 248.14	UL, CSA, VDE
	Hollyland Co Ltd	50CF 50CF(P)	F 15A, 250V	UL 248-14, CSA C22.2 NO. 248.14	UL, CUL
	LITTELFUSE INC for UL; Suzhou Littelfuse OVS Ltd for TUV	487 series	F 15A, 420V	IEC 60127-1, IEC 60127- 2, UL 248-14, CSA C22.2 NO. 248.14	UL, CSA, TUV
Fuse (F201)	Conquer Electronics Co Ltd	PBU	F 1A, 250Vac	UL 248-14, CSA C22.2 NO. 248.14, IEC 60127-1, IEC 60127-3, GB9364.1- 1997; GB9364.3- 1997	UL, CSA, VDE, CCC
Fuse (F3)	Conquer Electronics Co Ltd	PBP	F 6.3A, 250Vac	UL 248-14, CSA C22.2 NO. 248.14	UL, cCSAus
	Conquer Electronics Co Ltd	PGU	F 6.3A, 250Vac	UL 248-14, CSA C22.2 NO. 248.14, IEC 60127-1, IEC 60127-3	UL, CUL, VDE, CQC
	Sleetech Enterprise Inc.; Taiwan Electronical	37FG+	F 6.3A, 125Vac/250Vac/63Vdc	UL 248-14	UL

Constructional Data Form (CDF) for Electrical Appliances

Table B:

Critical Components

Material: e.g. external enclosure, closed-end connector, sleeves, cord anchorage etc

Components with winding: e.g. motor, transformer, magnetic coil etc.

Other components: e.g. switch, thermostat, heater, plug, internal wire, capacitor, relay, varistor etc.

Object/part No.	Manufacturer/ trademark	Type/ model	Technical data	Standard	Mark(s) of conformity
	Protector Co Ltd (Sleek Co Ltd)				
	Conquer Electronics Co Ltd	PBU	F6.3A, 250Vac	UL 248-14, CSA C22.2 NO. 248.14, IEC/EN 60127-1, IEC/EN 60127-3	UL, CUL, VDE, CCC
	WALTER ELECTRONIC CO LTD	FDP	F6.3A, 250Vac	UL 248-14, CSA C22.2 NO. 248.14, IEC/EN 60127-1, IEC/EN 60127-3	UL, CUL, VDE, CCC
X-Capacitor (C4, C7) C4 max. 1µF ; C7 max. 0.47µF (X1 or X2 type) (Optional)	Kemet Electronics Corporation for ENEC; Kemet Electronics Italia Srl for UL / Arcotronics	R.46	min. 250 Vac, 110 °C	IEC/EN 60384- 14:2013, ANSI/UL 60384-14, CAN/CSA- E60384-1, CAN/CSA- E60384-14	ENEC, UL, cUL
	Hua Jung Components Co., Ltd.	MKP	min. 250 Vac, 110 °C	IEC/EN 60384- 14:2013, ANSI/UL 60384-14, CAN/CSA- E60384-1, CAN/CSA- E60384-14	ENEC, UL, cUL, CSA, CQC
	Shenzhen	CBB62B	min. 250 Vac, 110 °C	IEC/EN	VDE, UL,

Constructional Data Form (CDF) for Electrical Appliances

Table B:

Critical Components

Material: e.g. external enclosure, closed-end connector, sleeves, cord anchorage etc

Components with winding: e.g. motor, transformer, magnetic coil etc.

Other components: e.g. switch, thermostat, heater, plug, internal wire, capacitor, relay, varistor etc.

Object/part No.	Manufacturer/ trademark	Type/ model	Technical data	Standard	Mark(s) of conformity
	Jinghao Capacitor Co., Ltd.			60384- 14:2013, ANSI/UL 60384-14, CAN/CSA- E60384-1, CAN/CSA- E60384-14	cUL, CQC
	Shenzhen Yimanfeng Science And Technology Co., Ltd.	MPX/MKP	min. 250 Vac, 110 °C	IEC/EN 60384- 14:2013, ANSI/UL 60384-14, CAN/CSA- E60384-1, CAN/CSA- E60384-14	VDE, UL, cUL, CQC
	Okaya Electric Industries Co., Ltd.	XF	min. 250 Vac, 110 °C	IEC/EN 60384- 14:2013, ANSI/UL 60384-14, CAN/CSA- E60384-1, CAN/CSA- E60384-14	ENEC, UL, cUL
	Strong Components Co., Ltd.	MPX	min. 250 Vac, 110 °C	IEC/EN 60384- 14:2013, ANSI/UL 60384-14, CAN/CSA- E60384-1, CAN/CSA- E60384-14	VDE, UL, cUL, CQC

Constructional Data Form (CDF) for Electrical Appliances

Table B:

Critical Components

Material: e.g. external enclosure, closed-end connector, sleeves, cord anchorage etc

Components with winding: e.g. motor, transformer, magnetic coil etc.

Other components: e.g. switch, thermostat, heater, plug, internal wire, capacitor, relay, varistor etc.

Object/part No.	Manufacturer/ trademark	Type/ model	Technical data	Standard	Mark(s) of conformity
	Vishay Capacitors Belgium NV	F1778	min. 250 Vac, 110 °C	IEC/EN 60384- 14:2013, ANSI/UL 60384-14, CAN/CSA- E60384-1, CAN/CSA- E60384-14	ENEC, UL, cUL, CQC
	Zhuhai Sung Ho Electronics Co., Ltd.	CMPP	min. 250 Vac, 110 °C	IEC/EN 60384- 14:2013, ANSI/UL 60384-14, CAN/CSA- E60384-1, CAN/CSA- E60384-14	VDE, UL, cUL, CSA, CQC
	Okaya Electric Industries Co., Ltd.	RE series	min. 250 Vac, 110 °C	IEC/EN 60384- 14:2013, ANSI/UL 60384-14, CAN/CSA- E60384-1, CAN/CSA- E60384-14	VDE, UL, cUL
	Okaya Electric Industries Co., Ltd.	LE series	min. 250 Vac, 110 °C	IEC/EN 60384- 14:2013, ANSI/UL 60384-14, CAN/CSA- E60384-1, CAN/CSA-	ENEC, UL, cUL

Constructional Data Form (CDF) for Electrical Appliances

Table B:

Critical Components

Material: e.g. external enclosure, closed-end connector, sleeves, cord anchorage etc

Components with winding: e.g. motor, transformer, magnetic coil etc.

Other components: e.g. switch, thermostat, heater, plug, internal wire, capacitor, relay, varistor etc.

Object/part No.	Manufacturer/ trademark	Type/ model	Technical data	Standard	Mark(s) of conformity
				E60384-14	
	Cheng Tung Industrial Co., Ltd.	CTX	min. 250 Vac, 110 °C	IEC/EN 60384-14:2013, ANSI/UL 60384-14, CAN/CSA-E60384-1, CAN/CSA-E60384-14	VDE, UL, cUL, CQC
	Epcos Electronic Components S.A.	B3292 series	min. 250 Vac, 110 °C	IEC/EN 60384-14:2013, ANSI/UL 60384-14, CAN/CSA-E60384-1, CAN/CSA-E60384-14	VDE, UL, cUL
	Vishay Capacitors Belgium NV	F1772	min. 250 Vac, 110 °C	IEC/EN 60384-14:2013, ANSI/UL 60384-14, CAN/CSA-E60384-1, CAN/CSA-E60384-14	VDE, UL, cUL
	Kemet Electronics Oy	PHE840M	min. 250 Vac, 110 °C	IEC/EN 60384-14:2013, ANSI/UL 60384-14, CAN/CSA-E60384-1,	ENEC, UL, cUL

Constructional Data Form (CDF) for Electrical Appliances

Table B:

Critical Components

Material: e.g. external enclosure, closed-end connector, sleeves, cord anchorage etc

Components with winding: e.g. motor, transformer, magnetic coil etc.

Other components: e.g. switch, thermostat, heater, plug, internal wire, capacitor, relay, varistor etc.

Object/part No.	Manufacturer/ trademark	Type/ model	Technical data	Standard	Mark(s) of conformity
				CAN/CSA- E60384-14	
	Carli Electronics Co., Ltd.	MPX	min. 250 Vac, 110 °C	IEC/EN 60384- 14:2013, ANSI/UL 60384-14, CAN/CSA- E60384-1, CAN/CSA- E60384-14	VDE, UL, cUL, CSA, CQC
	Panasonic Corporation Automotive & Ind. Systems Company Device Solutions Business Division doe VDE; Panasonic Corporation, Panasonic Corporation of North America for UL	ECQUL	min. 250 Vac, 110 °C	IEC/EN 60384- 14:2013, ANSI/UL 60384-14, CAN/CSA- E60384-1, CAN/CSA- E60384-14	VDE, UL, cUL, CSA
	Shenzhen Su Rong Capacitors Co., Ltd.	MPX/MKP	min. 250 Vac, 110 °C	IEC/EN 60384- 14:2013, ANSI/UL 60384-14, CAN/CSA- E60384-1, CAN/CSA- E60384-14	VDE, UL, cUL, CQC
Y-Capacitor	Murata Mfg. Co.,	KX	Min. 250 Vac, 125 °C	IEC/EN	VDE, UL,

Constructional Data Form (CDF) for Electrical Appliances

Table B:

Critical Components

Material: e.g. external enclosure, closed-end connector, sleeves, cord anchorage etc

Components with winding: e.g. motor, transformer, magnetic coil etc.

Other components: e.g. switch, thermostat, heater, plug, internal wire, capacitor, relay, varistor etc.

Object/part No.	Manufacturer/ trademark	Type/ model	Technical data	Standard	Mark(s) of conformity
(C198,C199, C5,C6) C198, C199 max. 2200 pF; C5,C6 max. 3300 pF (Y1 or Y2 type) (Optional)	Ltd.			60384- 14:2013, ANSI/UL 60384-14, CAN/CSA- E60384-1, CAN/CSA- E60384-14	CSA
	TDK Corporation	CD	Min. 250 Vac, 125 °C	IEC/EN 60384- 14:2013, ANSI/UL 60384-14, CAN/CSA- E60384-1, CAN/CSA- E60384-14	VDE, ENEC, UL, cUL, CQC
	Walsin Technology Corp.	AH	Min. 250 Vac, 125 °C	IEC/EN 60384- 14:2013, ANSI/UL 60384-14, CAN/CSA- E60384-1, CAN/CSA- E60384-14	VDE, ENEC, UL, cUL
	Success Electronics Co., Ltd.	SE	Min. 250 Vac, 125 °C	IEC/EN 60384- 14:2013, ANSI/UL 60384-14, CAN/CSA- E60384-1, CAN/CSA- E60384-14	VDE, ENEC, UL, cUL

Constructional Data Form (CDF) for Electrical Appliances

Table B:

Critical Components

Material: e.g. external enclosure, closed-end connector, sleeves, cord anchorage etc

Components with winding: e.g. motor, transformer, magnetic coil etc.

Other components: e.g. switch, thermostat, heater, plug, internal wire, capacitor, relay, varistor etc.

Object/part No.	Manufacturer/ trademark	Type/ model	Technical data	Standard	Mark(s) of conformity
	Vishay Electronic GmbH	VY1	Min. 250 Vac, 125 °C	IEC/EN 60384-14:2013, ANSI/UL 60384-14, CAN/CSA-E60384-1, CAN/CSA-E60384-14	VDE, UL, cUL
	Holy Stone Enterprise Co., Ltd.	SDC series	Min. 250 Vac, 125 °C	IEC/EN 60384-14:2013, ANSI/UL 60384-14, CAN/CSA-E60384-1, CAN/CSA-E60384-14	TÜV, UL, cUL
	Success Electronics Co., Ltd.	SB	Min. 250 Vac, 125 °C	IEC/EN 60384-14:2013, ANSI/UL 60384-14, CAN/CSA-E60384-1, CAN/CSA-E60384-14	VDE, ENEC, UL, cUL, CSA, CQC
	Yinan Don's Electronic Component Co., Ltd.	CT81	Min. 250 Vac, 125 °C	IEC/EN 60384-14:2013, ANSI/UL 60384-14, CAN/CSA-E60384-1, CAN/CSA-	VDE, UL, CSA, CQC

Constructional Data Form (CDF) for Electrical Appliances

Table B:

Critical Components

Material: e.g. external enclosure, closed-end connector, sleeves, cord anchorage etc

Components with winding: e.g. motor, transformer, magnetic coil etc.

Other components: e.g. switch, thermostat, heater, plug, internal wire, capacitor, relay, varistor etc.

Object/part No.	Manufacturer/ trademark	Type/ model	Technical data	Standard	Mark(s) of conformity
				E60384-14	
	Nanjing Yuyue Electronics Co., Ltd.	CT7 for VDE and CQC; CT7, 2B / CT7, 2E / CT7, 2F for UL	Min. 250 Vac, 125 °C	IEC/EN 60384-14:2013, ANSI/UL 60384-14, CAN/CSA-E60384-1, CAN/CSA-E60384-14	VDE, UL, cUL, CQC
	TDK Corporation	CS	Min. 250 Vac, 125 °C	IEC/EN 60384-14:2013, ANSI/UL 60384-14, CAN/CSA-E60384-1, CAN/CSA-E60384-14	VDE, ENEC, UL, cUL, CQC
	Walsin Technology Corp.	AC	Min. 250 Vac, 125 °C	IEC/EN 60384-14:2013, ANSI/UL 60384-14, CAN/CSA-E60384-1, CAN/CSA-E60384-14	VDE, ENEC, UL, cUL
	Success Electronics Co., Ltd.	SF	Min. 250 Vac, 125 °C	IEC/EN 60384-14:2013, ANSI/UL 60384-14, CAN/CSA-E60384-1,	VDE, ENEC, UL, cUL, CSA, CQC

Constructional Data Form (CDF) for Electrical Appliances

Table B:

Critical Components

Material: e.g. external enclosure, closed-end connector, sleeves, cord anchorage etc

Components with winding: e.g. motor, transformer, magnetic coil etc.

Other components: e.g. switch, thermostat, heater, plug, internal wire, capacitor, relay, varistor etc.

Object/part No.	Manufacturer/ trademark	Type/ model	Technical data	Standard	Mark(s) of conformity
				CAN/CSA- E60384-14	
Bridging Capacitor (C17) (C17 = max. 2200 pF) (Y1 type) (Optional)	Murata Mfg. Co., Ltd.	KX	Min. 250 Vac, 125 °C	IEC/EN 60384- 14:2013, ANSI/UL 60384-14, CAN/CSA- E60384-1, CAN/CSA- E60384-14	VDE, UL, CSA
	TDK Corporation	CD	Min. 250 Vac, 125 °C	IEC/EN 60384- 14:2013, ANSI/UL 60384-14, CAN/CSA- E60384-1, CAN/CSA- E60384-14	VDE, ENEC, UL, cUL, CQC
	Walsin Technology Corp.	AH	Min. 250 Vac, 125 °C	IEC/EN 60384- 14:2013, ANSI/UL 60384-14, CAN/CSA- E60384-1, CAN/CSA- E60384-14	VDE, ENEC, UL, cUL
	Success Electronics Co., Ltd.	SE	Min. 250 Vac, 125 °C	IEC/EN 60384- 14:2013, ANSI/UL 60384-14, CAN/CSA-	VDE, ENEC, UL, cUL

Constructional Data Form (CDF) for Electrical Appliances

Table B:

Critical Components

Material: e.g. external enclosure, closed-end connector, sleeves, cord anchorage etc

Components with winding: e.g. motor, transformer, magnetic coil etc.

Other components: e.g. switch, thermostat, heater, plug, internal wire, capacitor, relay, varistor etc.

Object/part No.	Manufacturer/ trademark	Type/ model	Technical data	Standard	Mark(s) of conformity
				E60384-1, CAN/CSA- E60384-14	
	Vishay Electronic GmbH	VY1	Min. 250 Vac, 125 °C	IEC/EN 60384- 14:2013, ANSI/UL 60384-14, CAN/CSA- E60384-1, CAN/CSA- E60384-14	VDE, UL, cUL
	Holy Stone Enterprise Co., Ltd.	SDC series	Min. 250 Vac, 125 °C	IEC/EN 60384- 14:2013, ANSI/UL 60384-14, CAN/CSA- E60384-1, CAN/CSA- E60384-14	TÜV, UL, cUL
	Success Electronics Co., Ltd.	SB	Min. 250 Vac, 125 °C	IEC/EN 60384- 14:2013, ANSI/UL 60384-14, CAN/CSA- E60384-1, CAN/CSA- E60384-14	VDE, ENEC, UL, cUL, CSA, CQC
	Yinan Don's Electronic Component Co., Ltd.	CT81	Min. 250 Vac, 125 °C	IEC/EN 60384- 14:2013, ANSI/UL 60384-14,	VDE, UL, CSA, CQC

Certificate No. R 50430418 Report No. 50226674 001 Appendix No. 1

Constructional Data Form (CDF) for Electrical Appliances

Page 14 of 35

Table B:

Critical Components

Material: e.g. external enclosure, closed-end connector, sleeves, cord anchorage etc

Components with winding: e.g. motor, transformer, magnetic coil etc.

Other components: e.g. switch, thermostat, heater, plug, internal wire, capacitor, relay, varistor etc.

Object/part No.	Manufacturer/ trademark	Type/ model	Technical data	Standard	Mark(s) of conformity
				CAN/CSA- E60384-1, CAN/CSA- E60384-14	
	Nanjing Yuyue Electronics Co., Ltd.	CT7 for VDE and CQC; CT7, 2B / CT7, 2E / CT7, 2F for UL	Min. 250 Vac, 125 °C	IEC/EN 60384- 14:2013, ANSI/UL 60384-14, CAN/CSA- E60384-1, CAN/CSA- E60384-14	VDE, UL, cUL, CQC
Varistor (MOV) (Optional)	Lien Shun Electronics Co., Ltd.	xxDyyyK (xx: 14, 20, 25; yyy: 471, 511, 561, 621, 681, 751, 781, 821, 911, 102, 112, 122)	300, 320, 350, 385, 420, 460, 485, 510, 550, 625, 680, 750 Vac; 40/85/56, 6kV/3kA pulse test passed (coating V-1 or better)	IEC 61051-1, IEC 61051-2, IEC 61051-2- 2, CECC 42000, CECC 42200, CECC 42001, IEC 60950-1 2nd Annex Q, ANSI/UL 1449, CSA Electrical Notice No. 516, CAN/CSA- C22.2 No. 8	VDE, UL, cUL
	Thinking Electronic Industrial Co., Ltd.	TVR10yyy-D series (yyy: 471, 511, 561, 621, 681, 751, 821, 911, 102, 112)	300, 320, 350, 395, 420, 465, 510, 550, 625, 680 Vac; 40/85/56, 6kV/3kA pulse test passed (coating V-1 or better)	IEC 61051-1, IEC 61051-2, IEC 61051-2- 2, CECC 42000, CECC 42200, CECC 42001,	VDE, UL, cUL

Constructional Data Form (CDF) for Electrical Appliances

Table B:

Critical Components

Material: e.g. external enclosure, closed-end connector, sleeves, cord anchorage etc

Components with winding: e.g. motor, transformer, magnetic coil etc.

Other components: e.g. switch, thermostat, heater, plug, internal wire, capacitor, relay, varistor etc.

Object/part No.	Manufacturer/ trademark	Type/ model	Technical data	Standard	Mark(s) of conformity
				IEC 60950-1 2nd Annex Q, ANSI/UL 1449, CSA Electrical Notice No. 516, CAN/CSA- C22.2 No. 8	
	Thinking Electronic Industrial Co., Ltd.	TVR10yyy-V series (yyy: 471, 511, 561, 621, 681, 751, 821, 911, 102, 112)	300, 320, 350, 395, 420, 465, 510, 550, 625, 680 Vac; 40/85/56, 6kV/3kA pulse test passed (coating V-1 or better)	IEC 61051-1, IEC 61051-2, IEC 61051-2- 2, CECC 42000, CECC 42200, CECC 42001, IEC 60950-1 2nd Annex Q, ANSI/UL 1449, CSA Electrical Notice No. 516, CAN/CSA- C22.2 No. 8	VDE, UL, cUL
	Thinking Electronic Industrial Co., Ltd.	TVRxyyyy series (xx: 14, 20; yyy: 471, 511, 561, 621, 681, 751, 821, 911, 102, 112)	300, 320, 350, 395, 420, 465, 510, 550, 625, 680 Vac; 40/85/56, 6kV/3kA pulse test passed (coating V-1 or better)	IEC 61051-1, IEC 61051-2, IEC 61051-2- 2, CECC 42000, CECC 42200, CECC 42001, IEC 60950-1 2nd Annex Q, ANSI/UL 1449, CSA	VDE, UL, cUL

Constructional Data Form (CDF) for Electrical Appliances

Table B:

Critical Components

Material: e.g. external enclosure, closed-end connector, sleeves, cord anchorage etc

Components with winding: e.g. motor, transformer, magnetic coil etc.

Other components: e.g. switch, thermostat, heater, plug, internal wire, capacitor, relay, varistor etc.

Object/part No.	Manufacturer/ trademark	Type/ model	Technical data	Standard	Mark(s) of conformity
				Electrical Notice No. 516, CAN/CSA- C22.2 No. 8	
	Thinking Electronic Industrial Co., Ltd.	TVRxyyy-M series (xx: 14, 20; yyy: 471, 511, 561, 621, 681, 751)	300, 320, 350, 395, 420, 465, 510, 550, 625, 680 Vac; 40/85/56, 6kV/3kA pulse test passed (coating V-1 or better)	IEC 61051-1, IEC 61051-2, IEC 61051-2- 2, CECC 42000, CECC 42200, CECC 42001, IEC 60950-1 2nd Annex Q, ANSI/UL 1449, CSA Electrical Notice No. 516, CAN/CSA- C22.2 No. 8	VDE, UL, cUL
	Joyin Co., Ltd.	xxSyyyK (xx: 10, 14, 20; yyy: 471, 511, 561, 621, 681, 751, 781, 821, 911, 102, 112)	300, 320, 350, 385, 420, 460, 485, 510, 550, 625, 680 Vac; 40/85/56, 6kV/3kA pulse test passed (coating V-1 or better)	IEC 61051-1, IEC 61051-2, IEC 61051-2- 2, CECC 42000, CECC 42200, CECC 42001, IEC 60950-1 2nd Annex Q, ANSI/UL 1449, CSA Electrical Notice No. 516, CAN/CSA-	VDE, UL, cUL, CSA

Certificate No. R 50430418 Report No. 50226674 001 Appendix No. 1

Constructional Data Form (CDF) for Electrical Appliances

Page 17 of 35

Table B:

Critical Components

Material: e.g. external enclosure, closed-end connector, sleeves, cord anchorage etc

Components with winding: e.g. motor, transformer, magnetic coil etc.

Other components: e.g. switch, thermostat, heater, plug, internal wire, capacitor, relay, varistor etc.

Object/part No.	Manufacturer/ trademark	Type/ model	Technical data	Standard	Mark(s) of conformity
				C22.2 No. 8	
	Joyin Co., Ltd.	xxNyyyK (xx: 10, 14, 20; yyy: 471, 511, 561, 621, 681, 751, 781, 821, 911, 102, 112, 182)	300, 320, 350, 385, 420, 460, 485, 510, 550, 625, 680, 1000 Vac; 40/85/56, 6kV/3kA pulse test passed (coating V-1 or better)	IEC 61051-1, IEC 61051-2, IEC 61051-2-2, CECC 42000, CECC 42200, CECC 42001, IEC 60950-1 2nd Annex Q, ANSI/UL 1449, CSA Electrical Notice No. 516, CAN/CSA-C22.2 No. 8	VDE, UL, cUL, CSA
	DongGuan Littelfuse Electronics Co., Ltd. for VDE; Littelfuse Inc. for UL	CIII-Series / LA-Series for VDE; VxxxLAyy series for UL (xxx: 300, 320, 385, 420, 460, 480, 510, 550, 575, 625, 660, 680; yy: 10, 20, 40, 50, 80, 100)	300, 320, 385, 420, 460, 480, 510, 550, 575, 625, 660, 680 Vac; 40/85/56, 6kV/3kA pulse test passed (coating V-1 or better)	IEC 61051-1, IEC 61051-2, IEC 61051-2-2, CECC 42000, CECC 42200, CECC 42001, IEC 60950-1 2nd Annex Q, ANSI/UL 1449, CSA Electrical Notice No. 516, CAN/CSA-C22.2 No. 8	VDE, UL, cUL
	EPCOS OHG for VDE; EPCOS (Zhuhai	S(NF)xxKyyy (xx: 14, 20; yyy: 300, 320, 350,	300, 320, 350, 385, 420, 440, 460, 510, 550, 625, 680, 1100 Vac; 40/85/56, 6kV/3kA	IEC 61051-1, IEC 61051-2, IEC 61051-2-	VDE, UL, cUL

Certificate No. R 50430418 Report No. 50226674 001 Appendix No. 1

Constructional Data Form (CDF) for Electrical Appliances

Page 18 of 35

Table B:

Critical Components

Material: e.g. external enclosure, closed-end connector, sleeves, cord anchorage etc

Components with winding: e.g. motor, transformer, magnetic coil etc.

Other components: e.g. switch, thermostat, heater, plug, internal wire, capacitor, relay, varistor etc.

Object/part No.	Manufacturer/ trademark	Type/ model	Technical data	Standard	Mark(s) of conformity
	FTZ) Co., Ltd. for UL	385, 420, 440, 460, 510, 550, 625, 680, 1000)	pulse test passed (coating V-1 or better)	2, CECC 42000, CECC 42200, CECC 42001, IEC 60950-1 2nd Annex Q, ANSI/UL 1449, CSA Electrical Notice No. 516, CAN/CSA- C22.2 No. 8	
	EPCOS OHG for VDE; EPCOS (Zhuhai FTZ) Co., Ltd. for UL	Q20Kyyy (yyy: 300, 320)	300, 320 Vac; 40/85/56, 6kV/3kA pulse test passed (coating V-1 or better)	IEC 61051-1, IEC 61051-2, IEC 61051-2- 2, CECC 42000, CECC 42200, CECC 42001, IEC 60950-1 2nd Annex Q, ANSI/UL 1449, CSA Electrical Notice No. 516, CAN/CSA- C22.2 No. 8	VDE, UL, cUL
	EPCOS OHG for VDE; EPCOS (Zhuhai FTZ) Co., Ltd. for UL	S(NF)10KyyyE2 K1 (yyy: 300, 320, 350, 385, 420, 460, 510, 550, 625, 680)	300, 320, 350, 385, 420, 440, 460, 510, 550, 625, 680 Vac; 40/85/56, 6kV/3kA pulse test passed (coating V-1 or better)	IEC 61051-1, IEC 61051-2, IEC 61051-2- 2, CECC 42000, CECC 42200, CECC 42001,	VDE, UL, cUL

Certificate No. R 50430418 Report No. 50226674 001 Appendix No. 1

Constructional Data Form (CDF) for Electrical Appliances

Page 19 of 35

Table B:

Critical Components

Material: e.g. external enclosure, closed-end connector, sleeves, cord anchorage etc

Components with winding: e.g. motor, transformer, magnetic coil etc.

Other components: e.g. switch, thermostat, heater, plug, internal wire, capacitor, relay, varistor etc.

Object/part No.	Manufacturer/ trademark	Type/ model	Technical data	Standard	Mark(s) of conformity
				IEC 60950-1 2nd Annex Q, ANSI/UL 1449, CSA Electrical Notice No. 516, CAN/CSA- C22.2 No. 8	
	Brightking (Shenzhen) Co., Ltd.	yyyKDxx (xx: 10, 14, 20; yyy: 471, 511, 561, 621, 681, 751, 781, 821, 911, 102, 112)	300, 320, 350, 385, 420, 460, 485, 510, 550, 625, 680 Vac; 40/85/56, 6kV/3kA pulse test passed (coating V-1 or better)	IEC 61051-1, IEC 61051-2, IEC 61051-2- 2, CECC 42000, CECC 42200, CECC 42001, IEC 60950-1 2nd Annex Q, ANSI/UL 1449, CSA Electrical Notice No. 516, CAN/CSA- C22.2 No. 8	VDE, UL, cUL
	Nippon Chemi- con Corporation	TND10SEyyyK/ TNR10SEyyyK series (yyy: 621, 681, 751, 781, 821, 911, 102, 112, 182) TND12SEyyyK/ TNR12SEyyyK series (yyy: 471, 511, 561, 621, 681, 751, 781,	300, 320, 350, 395, 420, 465, 510, 550, 625, 680 Vac; 40/85/56, 6kV/3kA pulse test passed (coating V-1 or better)	IEC 61051-1, IEC 61051-2, IEC 61051-2- 2, CECC 42000, CECC 42200, CECC 42001, IEC 60950-1 2nd Annex Q, ANSI/UL 1449, CSA	VDE, UL, cUL, CSA

Constructional Data Form (CDF) for Electrical Appliances

Table B:

Critical Components

Material: e.g. external enclosure, closed-end connector, sleeves, cord anchorage etc

Components with winding: e.g. motor, transformer, magnetic coil etc.

Other components: e.g. switch, thermostat, heater, plug, internal wire, capacitor, relay, varistor etc.

Object/part No.	Manufacturer/ trademark	Type/ model	Technical data	Standard	Mark(s) of conformity
		821, 911, 102, 112, 182)		Electrical Notice No. 516, CAN/CSA- C22.2 No. 8	
Optocoupler (M12, M13, M14, M16, M202, M203)	Everlight Electronics Co., Ltd.	CNY series for UL. CNY-171 series, CNY17F1 series, EL610. ("." Can be "balnk, A-Z or numbers and denote different pin shape.)	Dti = 0.5 mm, Int. cr = 6 mm, Ext. cr = 7.7 mm, thermal cycling test passed by FIMKO, min. 3000 Vac, 110 °C	DIN EN 60747-5- 2:2003, IEC/EN 60950-1, UL 1577, CSA Component Acceptance Service Notice No. 5	VDE, FI, UL
	Vishay Semiconductor GmbH	TCLT10xx series (xx can be "00- 03, 06-09"), TCLT11xx series (xx can be "01- 03, 06-09"), TCLT1600 series.	Ext. cr = 8.2 mm, thermal cycling test passed by FIMKO, min. 4800 Vac, 100 °C	DIN EN 60747-5- 2:2003, IEC/EN 60950-1, UL 1577, CSA Component Acceptance Service Notice No. 5	VDE, FI, UL, cUL, CQC
	Renesas Electronics Corporation	PS2381-1	Dti = 0.4 mm, Ext. cr = 8 mm, thermal cycling test passed by FIMKO, min. 5000 Vac, 115 °C	DIN EN 60747-5- 2:2003, IEC/EN 60950-1, UL 1577, CSA Component Acceptance	VDE, FI, UL, CSA, S, CQC

Certificate No. R 50430418 Report No. 50226674 001 Appendix No. 1

Constructional Data Form (CDF) for Electrical Appliances

Page 21 of 35

Table B:

Critical Components

Material: e.g. external enclosure, closed-end connector, sleeves, cord anchorage etc

Components with winding: e.g. motor, transformer, magnetic coil etc.

Other components: e.g. switch, thermostat, heater, plug, internal wire, capacitor, relay, varistor etc.

Object/part No.	Manufacturer/ trademark	Type/ model	Technical data	Standard	Mark(s) of conformity
				Service Notice No. 5	
	Cosmo Electronics Corporation	KT1yxx series (y can be "0-4 and 6", xx can be "CTR Rank, 00- zz")	Dti = 0.7 mm, Ext. cr = 8.6 mm, thermal cycling test passed by FIMKO, min. 4800 Vac, 115 °C	DIN EN 60747-5- 2:2003, IEC/EN 60950-1, UL 1577, CSA Component Acceptance Service Notice No. 5	VDE, FI, UL, cUL, TÜV, CQC
	Everlight Electronics Co., Ltd.	EL817 series	Dti = 0.5 mm, Int. cr = 6 mm, Ext. cr = 7.7 mm, thermal cycling test passed by NEMKO, min. 3000 Vac, 110 °C	DIN EN 60747-5- 2:2003, IEC/EN 60950-1, UL 1577, CSA Component Acceptance Service Notice No. 5	VDE, N, UL, cUL, CQC
	Renesas Electronics Corporation	PS2561 series	Dti = 0.4 mm, Ext. cr = 7 mm, thermal cycling test passed by FIMKO, min. 5000 Vac, 100 °C	DIN EN 60747-5- 2:2003, IEC/EN 60950-1, UL 1577, CSA Component Acceptance Service Notice No. 5	VDE, FI, UL, CSA, CQC

Constructional Data Form (CDF) for Electrical Appliances

Table B:

Critical Components

Material: e.g. external enclosure, closed-end connector, sleeves, cord anchorage etc

Components with winding: e.g. motor, transformer, magnetic coil etc.

Other components: e.g. switch, thermostat, heater, plug, internal wire, capacitor, relay, varistor etc.

Object/part No.	Manufacturer/ trademark	Type/ model	Technical data	Standard	Mark(s) of conformity
	Cosmo Electronics Corporation	K1010 series	Dti = 0.5 mm, Ext. cr = 6.5 mm, thermal cycling test passed by FIMKO, min. 5000 Vac, 115 °C	DIN EN 60747-5- 2:2003, IEC/EN 60950-1, UL 1577, CSA Component Acceptance Service Notice No. 5	VDE, FI, UL, cUL, TÜV, CQC
	Vishay Semiconductor GmbH	VOL617 series, VOL618A series	Dti = 0.4 mm, Ext. cr = 8.0 mm, thermal cycling test passed by FIMKO, min. 5000 Vac, 110 °C	DIN EN 60747-5- 2:2003, IEC/EN 60950-1, UL 1577, CSA Component Acceptance Service Notice No. 5	VDE, FI, UL, cUL, CQC
	Lite-On Technology Corporation	LTV-817	Dti = 0.8 mm, Ext. cr = 7.8 mm, thermal cycling test passed by FIMKO, min. 5000 Vac, 100 °C	DIN EN 60747-5- 2:2003, IEC/EN 60950-1, UL 1577, CSA Component Acceptance Service Notice No. 5	VDE, FI, UL, cUL, D, S, CQC
	Everlight Electronics Co.,	EL101 series	Dti = 0.4 mm, Ext. cr = 8.1 mm, thermal cycling test passed by NEMKO, min. 3000	DIN EN 60747-5- 2:2003,	VDE, UL, cUL, N, D,

Constructional Data Form (CDF) for Electrical Appliances

Table B:

Critical Components

Material: e.g. external enclosure, closed-end connector, sleeves, cord anchorage etc

Components with winding: e.g. motor, transformer, magnetic coil etc.

Other components: e.g. switch, thermostat, heater, plug, internal wire, capacitor, relay, varistor etc.

Object/part No.	Manufacturer/ trademark	Type/ model	Technical data	Standard	Mark(s) of conformity
	Ltd.		Vac, 110 °C	IEC/EN 60950-1, UL 1577, CSA Component Acceptance Service Notice No. 5	CQC
	Lite-On Technology Corporation	LTV-100x (x can be 0-9)	Dti = 0.4 mm, Ext. cr = 8.3 mm, thermal cycling test passed by FIMKO, min. 5000 Vac, 100 °C	DIN EN 60747-5- 2:2003, IEC/EN 60950-1, UL 1577, CSA Component Acceptance Service Notice No. 5	VDE, FI, UL, cUL, D, N, CQC
Relay (REL1) (Optional)	Good Sky Electric Co. Ltd.	GQ-SH-112LM1	250Vac, 10A for TUV 125/250Vac, 10A for UL	UL 508, CAN/CS A C22.2 NO. 14, IEC 61810- 1:2008, EN 61810- 1:2008	UL,CUL,TÜV Rh
	Song Chuan Precision Co Ltd	307HN-1AH-F-C	277Vac, 10A for UL; 250Vac, 10A for VDE	UL 508, CAN/CS A C22.2 NO. 14, IEC 61810- 1:2008, EN 61810- 1:2008	UL,CUL,VDE

Constructional Data Form (CDF) for Electrical Appliances

Table B:

Critical Components

Material: e.g. external enclosure, closed-end connector, sleeves, cord anchorage etc

Components with winding: e.g. motor, transformer, magnetic coil etc.

Other components: e.g. switch, thermostat, heater, plug, internal wire, capacitor, relay, varistor etc.

Object/part No.	Manufacturer/ trademark	Type/ model	Technical data	Standard	Mark(s) of conformity
	XIAMEN HONGFA ELECTROACOUSTIC CO LTD	HF32FV series HF32FV-G series	250Vac, 10A	UL 508, CAN/CS A C22.2 NO. 14, IEC 61810- 1:2008, EN 61810- 1:2008	UL,CUL,VDE, CQC
	DONGGUAN GOLDEN	GI-1A-12LHF GI series	250Vac, 10A	UL 508, CAN/CS A C22.2 NO. 14, IEC 61810- 1:2008, EN 61810- 1:2015	UL,CUL,VDE
Isolator (M6,M8)	Silicon Laboratories Inc	Si8233BD-D	Minimum 5000Vac Insulation thickness =0.4mm, thermal cycling tested by VDE, external creepage=8.6 mm, 125°C	IEC 60950-1, UL 1577, CSA CA5A, 14-10, 60950-1-07, DIN EN 60747-5-2	UL,CSA,TÜV, VDE, CQC
Choke (L1)	AcBel Polytech Inc.(API)	21Q84	105°C min.	--	--
Choke (L4)	AcBel Polytech Inc.(API)	21O11	105°C min.	--	--
Choke (L5)	AcBel Polytech Inc.(API)	21R15	130°C min.	--	--
Transformer (T5)	AcBel Polytech Inc.(API)	25P07	Class B	Applicable parts of IEC	Accepted by TÜV

TÜV Rheinland Group

Feb. 21, 2019 Kevin Chang 

Date Printed Name Signature

Feb. 21, 2019 Evonne Lai 

Date Printed Name Stamp&Signature of licenseholder

(name of authorized person)

Certificate No. R 50430418 Report No. 50226674 001 Appendix No. 1

Constructional Data Form (CDF) for Electrical Appliances

Page 25 of 35

Table B:

Critical Components

Material: e.g. external enclosure, closed-end connector, sleeves, cord anchorage etc

Components with winding: e.g. motor, transformer, magnetic coil etc.

Other components: e.g. switch, thermostat, heater, plug, internal wire, capacitor, relay, varistor etc.

Object/part No.	Manufacturer/ trademark	Type/ model	Technical data	Standard	Mark(s) of conformity
				62368-1 and according to IEC 60085	Rheinland
- Triple Insulated Wire used in T5	Totoku Electric Co., Ltd.	TIW-2	130 °C, electric strength: 4000 Vrms	IEC/EN 60950-1, UL 2353, CAN/CSA C22.2 No. 60950-1	VDE, TÜV, UL, CSA
	Totoku Electric Co., Ltd.	TIW-3	155 °C, electric strength: 4000 Vrms	IEC/EN 60950-1, UL 2353, CAN/CSA C22.2 No. 60950-1	VDE, TÜV, UL, CSA
	Cosmolink Co., Ltd.	TIW-M	130 °C, electric strength: 3000 Vrms	IEC/EN 60950-1 UL 2353	VDE, UL
	Furukawa Electric Co., Ltd.	TEX-E	130 °C, electric strength: 3000 Vrms	IEC/EN 60950-1 UL 2353, CAN/CSA C22.2 No. 60950-1	VDE, TÜV, UL, CSA
Transformer (T201)	AcBel Polytech Inc.(API)	25P05	Class B	Applicable parts of IEC 62368-1 and according to IEC 60085	Accepted by TÜV Rheinland
- Triple Insulated Wire used in T201	Totoku Electric Co., Ltd.	TIW-2	130 °C, electric strength: 4000 Vrms	IEC/EN 60950-1 UL 2353, CAN/CSA C22.2 No.	VDE, TÜV, UL, CSA

Constructional Data Form (CDF) for Electrical Appliances

Table B:

Critical Components

Material: e.g. external enclosure, closed-end connector, sleeves, cord anchorage etc

Components with winding: e.g. motor, transformer, magnetic coil etc.

Other components: e.g. switch, thermostat, heater, plug, internal wire, capacitor, relay, varistor etc.

Object/part No.	Manufacturer/ trademark	Type/ model	Technical data	Standard	Mark(s) of conformity
				60950-1	
	Totoku Electric Co., Ltd.	TIW-3	155 °C, electric strength: 4000 Vrms	IEC/EN 60950-1 UL 2353, CAN/CSA C22.2 No. 60950-1	VDE, TÜV, UL, CSA
	Cosmolink Co., Ltd.	TIW-M	130 °C, electric strength: 3000 Vrms	IEC/EN 60950-1 UL 2353	VDE, UL
	Furukawa Electric Co., Ltd.	TEX-E	130 °C, electric strength: 3000 Vrms	IEC/EN 60950-1 UL 2353, CAN/CSA C22.2 No. 60950-1	VDE, TÜV, UL, CSA
Transformer (T401)	AcBel Polytech Inc. (API)	25P56	Class B	Applicable parts of IEC 62368-1 and according to IEC 60085	Accepted by TÜV Rheinland
- Triple Insulated Wire used in T401	Totoku Electric Co., Ltd.	TIW-2	130 °C, electric strength: 4000 Vrms	IEC/EN 60950-1 UL 2353, CAN/CSA C22.2 No. 60950-1	VDE, TÜV, UL, CSA
	Totoku Electric Co., Ltd.	TIW-3	155 °C, electric strength: 4000 Vrms	IEC/EN 60950-1 UL 2353, CAN/CSA C22.2 No. 60950-1	VDE, TÜV, UL, CSA
	Cosmolink Co.,	TIW-M	130 °C, electric strength: 3000	IEC/EN	VDE, UL

Constructional Data Form (CDF) for Electrical Appliances

Table B:

Critical Components

Material: e.g. external enclosure, closed-end connector, sleeves, cord anchorage etc

Components with winding: e.g. motor, transformer, magnetic coil etc.

Other components: e.g. switch, thermostat, heater, plug, internal wire, capacitor, relay, varistor etc.

Object/part No.	Manufacturer/ trademark	Type/ model	Technical data	Standard	Mark(s) of conformity
	Ltd.		Vrms	60950-1 UL 2353	
	Furukawa Electric Co., Ltd.	TEX-E	130 °C, electric strength: 3000 Vrms	IEC/EN 60950-1 UL 2353, CAN/CSA C22.2 No. 60950-1	VDE, TÜV, UL, CSA
DC Fan	ASIA VITAL COMPONENTS CO LTD	DBTD0428B2G(V), where (V) may be xxxx, where x may be A through Z, 0 through 9, "-", or blank.	12V, 1.5A, 31.16CFM	IEC 60950-1, UL 507, CSA C22.2 NO. 113	UL, CUL or CSA, VDE or TÜV PS or TÜV RH
	ASIA VITAL COMPONENTS CO LTD	DBTD0428B2G(V), where (V) may be xxxx, where x may be A through Z, 0 through 9, "-", or blank.	12V, 1.5A, 31.27 CFM	IEC 60950-1, UL 507, CSA C22.2 NO. 113	UL, CUL or CSA, VDE or TÜV PS or TÜV RH
	NIDEC TAIWAN CORP	(a)40S12BGD5- (X)(Z), where(a) may be W or V; (X) may be 01, 02, 06 or 07; (Z) may be xxxxxx, where x may be 0 through 9, A through Z, a through z or blank.	12V, 1.0A, 27.8CFM	IEC 60950-1, UL 507, CSA C22.2 NO. 113	UL, CUL or CSA, VDE or TÜV PS or TÜV RH
	DONGGUAN PROTECHNIC	MG(a)4012(y)B- (f)28, where (a)	12V, 1.2A, 28.64CFM	IEC 60950-1, UL 507, CSA	UL, CUL or CSA, VDE or

Constructional Data Form (CDF) for Electrical Appliances

Table B:

Critical Components

Material: e.g. external enclosure, closed-end connector, sleeves, cord anchorage etc

Components with winding: e.g. motor, transformer, magnetic coil etc.

Other components: e.g. switch, thermostat, heater, plug, internal wire, capacitor, relay, varistor etc.

Object/part No.	Manufacturer/ trademark	Type/ model	Technical data	Standard	Mark(s) of conformity
	ELECTRIC CO LTD	may be A or T, (y) may be V, W or P, (f) may be A thru Z, a thru z or blank.		C22.2 NO. 113	TÜV PS or TÜV RH
	FOXCONN TECHNOLOGY CO LTD	PIA040H12Q(Y), where (Y) may be xxxxxx, where x may be A through Z, 0 through 9, "-" or blank.	12V, 1.7A, 30.64CFM	IEC 60950-1, UL 507, CSA C22.2 NO. 113	UL, CUL or CSA, VDE or TÜV PS or TÜV RH
	MINEBEA CO LTD for UL ; NMB Technologies Corporation for VDE	04028DA-12S- (d)(e)G-(f), where (d) may be "A", "B", "C", "E", "F", "G", "S", "T", "U", "W", "Y", or "Z"; (e) may be "A", "B", "L", "M", "T", "U", "E", "F", "G", "H", "J", "K", "C", "D", "N", "P", "V", "W" or 1-6; (f) may be any alphanumeric characters.	12V, 1.4A, 27.6CFM	IEC 60950-1, UL 507, CSA C22.2 NO. 113	UL, CUL or CSA, VDE or TÜV PS or TÜV RH
Insulation Sheet (Between primary and metal case; between C36 and PCB3)	Formex, Div of Illinois Tool Works Inc, Formerly	FORMEX-18	Min. 0.20 mm, VTM-0; min. 0.41 mm, V-0	ANSI/UL 94	UL, cUL

Constructional Data Form (CDF) for Electrical Appliances

Table B:

Critical Components

Material: e.g. external enclosure, closed-end connector, sleeves, cord anchorage etc

Components with winding: e.g. motor, transformer, magnetic coil etc.

Other components: e.g. switch, thermostat, heater, plug, internal wire, capacitor, relay, varistor etc.

Object/part No.	Manufacturer/ trademark	Type/ model	Technical data	Standard	Mark(s) of conformity
	Formex, Div of Illinois Tool Works Inc, Formerly	FORMEX GK- (a)(b) (a) - One to three digit suffix indicating nominal thickness in mils. (b) - May have additional suffix letter(s) indicating color.	Min. 0.05 mm, VTM-0; min. 0.37 mm, V-0	ANSI/UL 94	UL, cUL
	Sabic Innovative Plastic BV / Sabic Innovative Plastic US L L C / Sabic Japan L L C	FR700, FR60	Min. 0.051 mm, VTM-0 (CL); min. 0.13 mm, VTM-0 (CL,BK); min. 0.23 mm, V-0 (All)	ANSI/UL 94	UL
	Sabic Innovative Plastic US L L C / Sabic Japan L L C	FR1	Min. 0.08 mm, VTM-2 (NC); min. 0.13 mm, VTM-0 (NC, BK); min. 0.63 mm V-0 (All)	ANSI/UL 94	UL
	Sabic Innovative Plastic US L L C / Sabic Japan L L C	EFR95	Min. 0.25 mm, VTM-0 (BK); min. 0.38 mm, V-0 (BK); min. 0.43 mm, V-0 (NC)	ANSI/UL 94	UL
	Sun Delta Corp.	VS(f); (f) - May be replaced by any digit 000- 999, except 560 and 160	Min. 0.2 mm, VTM-0 (NC, BK)	ANSI/UL 94	UL
	Toray Industries Inc.	Lumirror (#) (#) - Followed by F60, F60C, L11, Q55 or	0.023- 0.23 mm, VTM-2 (NC)	ANSI/UL 94	UL

Constructional Data Form (CDF) for Electrical Appliances

Table B:

Critical Components

Material: e.g. external enclosure, closed-end connector, sleeves, cord anchorage etc

Components with winding: e.g. motor, transformer, magnetic coil etc.

Other components: e.g. switch, thermostat, heater, plug, internal wire, capacitor, relay, varistor etc.

Object/part No.	Manufacturer/ trademark	Type/ model	Technical data	Standard	Mark(s) of conformity
		(a)(b)(c)(d) , where; (a) can be one letter H,K,S,T or W. (b) denotes a one digit number 0 - 7. (c) may be one digit number 0 - 9 or one letter A - M. (d) may be one digit number 0-9 or one letter A,C,E,K,M,V,W or Z. <>			
	Yi-Hsin Plastech Co., Ltd.	YIMEX PP-17	0.43-0.47 mm, V-0 (BK)	ANSI/UL 94	UL, cUL
	Yi-Hsin Plastech Co., Ltd.	HSINMEX PC - 175	Min. 0.25 mm, V-0 (BK)	ANSI/UL 94	UL, cUL
	Shenzhen Bornsun Industrial Co. Ltd.	BN-ZD16	Min. 0.25 mm, V-0 (BK)	ANSI/UL 94	UL, cUL
	Shenzhen Bornsun Industrial Co. Ltd.	BN-FP	0.25 mm, V-0	ANSI/UL 94	UL, cUL
PCB Material (for PCB1)	Plotech Co., Ltd.	4	V-0, 130 °C	ANSI/UL 94, ANSI/UL 796	UL
	Eiso Enterprise Co., Ltd.	3, 6	V-0, 130 °C	ANSI/UL 94, ANSI/UL 796	UL
	Elec&Eltek Co., Ltd.	E3330FL	V-0, 130 °C	ANSI/UL 94, ANSI/UL 796	UL

Constructional Data Form (CDF) for Electrical Appliances

Table B:

Critical Components

Material: e.g. external enclosure, closed-end connector, sleeves, cord anchorage etc

Components with winding: e.g. motor, transformer, magnetic coil etc.

Other components: e.g. switch, thermostat, heater, plug, internal wire, capacitor, relay, varistor etc.

Object/part No.	Manufacturer/ trademark	Type/ model	Technical data	Standard	Mark(s) of conformity
	Gold Circuit Electronics Ltd.	D-V0A, T-V0A	V-0, 130 °C	ANSI/UL 94, ANSI/UL 796	UL
	Gold Circuit Electronics Ltd.	H	V-0, 130 °C	ANSI/UL 94, ANSI/UL 796	UL
	Guang Dong Ellington Electronics Technology Co., Ltd.	ET856, ET866, ET566, ET866A	V-0, 130 °C	ANSI/UL 94, ANSI/UL 796	UL
	New Era Electronics Co., Ltd.	TC, 2M	V-0, 130 °C	ANSI/UL 94, ANSI/UL 796	UL
	Palwonn Electronics (Shenzhen) Co., Ltd.	M2, M3, M5, M8	V-0, 130 °C	ANSI/UL 94, ANSI/UL 796	UL
	Plotech Co., Ltd.	5, 6	V-0, 130 °C	ANSI/UL 94, ANSI/UL 796	UL
	Remapp Industrial Co., Ltd.	RM04TG	V-0, 130 °C	ANSI/UL 94, ANSI/UL 796	UL
	Shenzhen Kinwong Electronic Co., Ltd.	8B, 8F	V-0, 130 °C	ANSI/UL 94, ANSI/UL 796	UL
	Treasure Electronic Technology (Shenzhen) Ltd.	T-M1	V-0, 130 °C	ANSI/UL 94, ANSI/UL 796	UL
	Palwonn Electronics (Shenzhen) Co.,	M6	V-0, 105 °C	ANSI/UL 94, ANSI/UL 796	UL

Constructional Data Form (CDF) for Electrical Appliances

Table B:

Critical Components

Material: e.g. external enclosure, closed-end connector, sleeves, cord anchorage etc

Components with winding: e.g. motor, transformer, magnetic coil etc.

Other components: e.g. switch, thermostat, heater, plug, internal wire, capacitor, relay, varistor etc.

Object/part No.	Manufacturer/ trademark	Type/ model	Technical data	Standard	Mark(s) of conformity
	Ltd.				
	APCB Inc (Competitor Printed Circuit Board)	77	V-0, 130 °C	ANSI/UL 94, ANSI/UL 796	UL
	Suntak Multilayer PCB Co., Ltd.	STM-4, STM-6	V-0, 130 °C	ANSI/UL 94, ANSI/UL 796	UL
	Elec&Eltek Co., Ltd.	E3330RN	V-0, 130 °C	ANSI/UL 94, ANSI/UL 796	UL
	Palwonn Electronics (Shenzhen) Co., Ltd.	M7	V-0, 130 °C	ANSI/UL 94, ANSI/UL 796	UL
Heat Shrinkable Tubing (for LED wires, and DC fan wires)	3M Company Electrical Markets Div. (EMD)	FP-301VW	Min. 0.4 mm, VW-1, 600 V, 125 °C (All colors except clear)	ASNI/UL 224	UL
	Changyuan Electronics Group Co., Ltd.	CB-HFT	Min. 0.4 mm, VW-1, 300 V&600 V, 125 °C (All colors except clear)	ANSI/UL 224, CAN/CSA C22.2 No. 198.1- 06	UL, cUL
	Hamburg Industries Co., Ltd.	H-2	Min. 0.4 mm, VW-1, 600 V, 125 °C (All colors except clear)	ANSI/UL 224, CAN/CSA C22.2 No. 198.1- 06	UL, cUL
	Sumitomo Electric Fine Polymer Inc.	SUMITUBE F2, SUMITUBE F32	Min. 0.4 mm, VW-1, 600 V, 125 °C (All colors except clear)	ANSI/UL 224	UL
	Tyco Electronics Corp.	VERSAFIT	Min. 0.4 mm, VW-1, 600 V, 125 °C (All colors except clear)	ANSI/UL 224	UL

Constructional Data Form (CDF) for Electrical Appliances

Table B:

Critical Components

Material: e.g. external enclosure, closed-end connector, sleeves, cord anchorage etc

Components with winding: e.g. motor, transformer, magnetic coil etc.

Other components: e.g. switch, thermostat, heater, plug, internal wire, capacitor, relay, varistor etc.

Object/part No.	Manufacturer/ trademark	Type/ model	Technical data	Standard	Mark(s) of conformity
	Kai Suh Suh Enterprise Co., Ltd.	K32	Min. 0.4 mm, VW-1, 600 V, 125 °C (All colors except clear)	ANSI/UL 224	UL
	Sumitomo Electric Fine Polymer Inc.	717 or Sumitube NHR2	Min. 0.4 mm, VW-1, 600 V, 125 °C (Pink, yellow, blue, green, red, gray, and black)	ANSI/UL 224	UL
	Tyco Electronics Corp.	ZH2	Min. 0.4 mm, VW-1, 600 V, 125 °C (Black)	ANSI/UL 224	UL
	Shenzhen Woer Heat-Shrinkable Material Co., Ltd.	RSFR-HPF	Min. 0.4 mm, VW-1, 600 V, 125 °C (All colors except clear)	ANSI/UL 224, CAN/CSA C22.2 No. 198.1- 06	UL, cUL
	Changyuan Electronics Group Co., Ltd.	CYG-ZHP	Min. 0.4 mm, VW-1, 600 V, 125 °C (All except clear)	ANSI/UL 224, CAN/CSA C22.2 No. 198.1- 06	UL, cUL
	Dongguan Salipt Co., Ltd.	SALIPT S-901- 600	Min. 0.4 mm, VW-1, 600 V, 125 °C (All except clear)	ANSI/UL 224, CAN/CSA C22.2 No. 198.1- 06	UL, cUL
	Changyuan Electronics Group Co., Ltd.	CB-300	Min. 0.4 mm, VW-1, 300 V, 105 °C (Black)	ANSI/UL 224	UL
	Develop Electric Co., Ltd.	DEV-300	Min. 0.4 mm, VW-1, 300 V, 105 °C (All colors)	ANSI/UL 224	UL
	Qifurui Electronics Co.	QFR-PVC-300	Min. 0.4 mm, VW-1, 300 V, 105 °C (Black)	ANSI/UL 224, CAN/CSA C22.2 No. 198.1- 06	UL, cUL
	Qifurui Electronics Co.	QFR-PVC-600	Min. 0.4 mm, VW-1, 600 V, 105 °C (Black)	ANSI/UL 224, CAN/CSA C22.2 No.	UL, cUL

Constructional Data Form (CDF) for Electrical Appliances

Table B:

Critical Components

Material: e.g. external enclosure, closed-end connector, sleeves, cord anchorage etc

Components with winding: e.g. motor, transformer, magnetic coil etc.

Other components: e.g. switch, thermostat, heater, plug, internal wire, capacitor, relay, varistor etc.

Object/part No.	Manufacturer/ trademark	Type/ model	Technical data	Standard	Mark(s) of conformity
				198.1- 06	
	Kai Suh Suh Enterprise Co., Ltd.	NHS	Min. 0.4 mm, VW-1, 300 V&600 V, 105 °C (All colors)	ANSI/UL 224	UL
	Shenzhen Gaoertai Electronics Co., Ltd.	GET300	Min. 0.4 mm, VW-1, 300 V, 105°C, (All colors)	ANSI/UL 224, CAN/CSA C22.2 No. 198.1- 06	UL, cUL
	Shenzhen Gaoertai Electronics Co., Ltd.	GET600	Min. 0.4 mm, VW-1, 600 V, 105°C, (All colors)	ANSI/UL 224, CAN/CSA C22.2 No. 198.1- 06	UL, cUL
Bleeder Resistor (RHV1, RHV2, RHV3)	RALEC TECHNOLOGY (KUNSHAN) CO., LTD.	RTV05 series, RTV06 series, RTV12 series, RTV20 series, RTV25 series	1/4W, 220KΩ	IEC 62368- 1(ed.2), CB by Demko	--
	TA-I Technology Co Ltd	RH series RH10 series, RH12 series	1/4W, 220KΩ	IEC 62368- 1(ed.2), IEC 60950- 1(ed.2);am2 CB by Demko	--
	Yageo Corp	RV1206 series	1/4W, 220KΩ	IEC 62368- 1:2014 (CB issued by Nemko)	--
	Kamaya Electric Co Ltd	RVC32 series	1/4W, 220KΩ	IEC/EN 60950- 1:2005 (CB issued by Intertek, Ref. No. TP10030283- ETS)	--

TÜV Rheinland Group

Feb. 21, 2019 Kevin Chang



Feb. 21, 2019

Evonne Lai

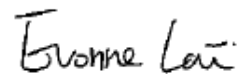

Date

Printed Name

Signature

Date

Printed Name

Stamp&Signature of licenseholder

(name of authorized person)

Constructional Data Form (CDF) for Electrical Appliances

Table B:

Critical Components

Material: e.g. external enclosure, closed-end connector, sleeves, cord anchorage etc

Components with winding: e.g. motor, transformer, magnetic coil etc.

Other components: e.g. switch, thermostat, heater, plug, internal wire, capacitor, relay, varistor etc.

Object/part No.	Manufacturer/ trademark	Type/ model	Technical data	Standard	Mark(s) of conformity
	Viking Tech Corporation Kaoshiung Branch	HVR02 series, HVR03 series, HVR05 series, HVR06 series, HVR0A series, HVR12 series	1/4W, 220KΩ	IEC 62368- 1(ed.2), IEC 60950- 1(ed.2);am2, CB issued by Demko	--
	Yageo Corporation	RV0603 series, RV0805 series, RV1206 series	1/4W, 220KΩ	IEC 62368- 1(ed.2), CB issued by Demko	--

Table C:

Functional Components

Components which are required for performance purposes and not directly addressed by a component standard or product standard: Ripple capacitors, Mosfets, PCB, etc.

Object/part No.	Type/ model (optional)	Technical data
Thermistor (RT2, RT3, RT7, RT301)	Interchangeable	10 kΩ at 25 °C, NTC
Thermistor (RT1)	Interchangeable	25 Ω at 25 °C, PTC
Bridge Diode (BD1)	Interchangeable	Min. 25 A, min. 600 V
Electrolytic Capacitor (C36)	Interchangeable	560 μF, min. 450 V, min. 105 °C
Transistor (Q1, Q11, Q2, Q21)	Interchangeable	Min. 20 A, min. 600 V
Metal Chassis	Interchangeable	Metallic, thickness 0.8 mm min.
PCB (for PCB2, PCB3, PCB4 and PCB5)	Interchangeable	V-1 or better, min. 105 °C

CERTIFICATE OF COMPLIANCE

Certificate Number 20190416-E131875
Report Reference E131875-20190321
Issue Date 2019-APRIL-16

Issued to: ACBEL POLYTECH INC
No159 Sec 3 Danjin Rd
TamSui District
New Taipei 251 TAIWAN

**This certificate confirms that
representative samples of**

COMPONENT - POWER SUPPLIES FOR USE WITH
AUDIO/VIDEO, INFORMATION AND COMMUNICATION
TECHNOLOGY EQUIPMENT

Switching Power Supply
FSF050, R1CA2122A

Have been investigated by UL in accordance with the
component requirements in the Standard(s) indicated on
this Certificate. UL Recognized components are incomplete
in certain constructional features or restricted in
performance capabilities and are intended for installation in
complete equipment submitted for investigation to UL LLC.

Standard(s) for Safety: UL 62368-1 and CAN/CSA C22.2 No.62368-1-14
Audio/video, information and communication technology
equipment – Part 1: Safety requirements

Additional Information: See the UL Online Certifications Directory at
<https://iq.ulprospector.com> for additional information.

This *Certificate of Compliance* does not provide authorization to apply the UL Recognized Component Mark. Only the UL Follow-Up Services Procedure provides authorization to apply the UL Mark.

Only those products bearing the UL Recognized Component Mark should be considered as being UL Certified and covered under UL's Follow-Up Services.

Look for the UL Recognized Component Mark on the product.



Bruce Mahrenholz, Director North American Certification Program
UL LLC

Any information and documentation involving UL Mark services are provided on behalf of UL LLC (UL) or any authorized licensee of UL. For questions, please contact a local UL Customer Service Representative at <http://ul.com/aboutul/locations/>



經濟部標準檢驗局

BUREAU OF STANDARDS, METROLOGY AND INSPECTION,
MINISTRY OF ECONOMIC AFFAIRS



商品驗證登錄證書

CERTIFICATE OF THE REGISTRATION OF PRODUCT CERTIFICATION

證書號碼： CI331065679327 號 00
Certificate No.

茲據 康舒科技股份有限公司
定，准予登錄並使用商品安全標章  及識別號碼：
The application made by

申請驗證登錄，經審查結果符合規
R33567 。其登錄事項如下：
for Registration of Product

Certification has been reviewed and found to be in compliance with related regulations. Therefore, registration is granted with the
Product Safety Mark  and the Identification No. R33567 . Details of the registration are follows :

申請人：康舒科技股份有限公司
Applicant

統一編號：12341051
Uniform No.

地址：台北市松山區南京東路五段99號11樓
Address

生產廠場：詳如附表
Factory

廠址：詳如附表
Factory Address

商品種類名稱：
Type/name of product

商品分類號列：8504.40.91.00.7-A
C.C.C Code

中文名稱：交換式電源供應器
Chinese name

英文名稱：SWITCHING POWER SUPPLY
English name

型式：FSF050
Type

系列型式：R1CA2122A(以下空白)
Series of the type

依據標準：CNS15598-1 (109年06月)、CNS15936 (105年09月)、符合CNS 15663第5節「
Standards 含有標示」規定 (102年版)



標準檢驗局發證 (發證地址：100臺北市中正區濟南路1段4號)

This certificate is issued by the BSMI. (No.4, Sec. 1, Jinan Rd., Zhongzheng Dist., Taipei City 100, Taiwan)

本證書以電子文件行之，所載內容若有不符之處，以標準檢驗局系統登錄資料為主，查詢證書
資料網址：<https://civil.bsmi.gov.tw>

登錄日期：中華民國	111	年	12	月	23	日
Registration Date	2022	(year)	12	(month)	23	(day)
本證書有效期限至	114	年	12	月	22	日
Expiration Date	2025	(year)	12	(month)	22	(day)
發證日期：中華民國	111	年	12	月	22	日
Date of issue	2022	(year)	12	(month)	22	(day)



註1：持本證書進口驗證登錄商品時，進口人須與本證書名義人相同。

註2：次年度商品驗證登錄年費繳納期限為當年11月30日，逾期未繳納者，經限期繳納屆期未繳納，即依商品檢
驗法第42條第7款規定廢止驗證登錄，並自次年度1月1日起生效。

註3：本證書僅代表完成檢驗程序，不作為其他(如產地)證明。

經濟部標準檢驗局
BUREAU OF STANDARDS, METROLOGY AND INSPECTION,
MINISTRY OF ECONOMIC AFFAIRS

商品驗證登錄證書
CERTIFICATE OF THE REGISTRATION OF PRODUCT CERTIFICATION

證書號碼： CI331065679327 號 00
Certificate No.

- 生產廠場： 1. Acbel Polytech (Philippines) Inc.
Factory： No. 2 Tagaytay Ridge Drive, Carmelray Industrial Park II, Km. 54 National Highway, Calamba City, Laguna 4027, Philippines
2. ACBEL ELECTRONIC (WUHAN) CO., LTD
No. 1, Du Tai North Road Economic Development Zone
XianTao City, Hubei Province P.R. China
3. Acbel Polytech Inc.
No. 159, Sec. 3, Danjin Rd., Tamsui Dist., New Taipei City 251, Taiwan, R.O.C.
4. AcBel Electronic (Dong guan) Co., Ltd.
No.17-28, Hong Yeh Road, Hong Yeh Ind. District, Tang Xia Town, DongGuan, Guangdong, 523710 P.R. China

(以下空白)



經濟部標準檢驗局

BUREAU OF STANDARDS, METROLOGY AND INSPECTION,
MINISTRY OF ECONOMIC AFFAIRS



商品驗證登錄電子證書
CERTIFICATE OF THE REGISTRATION OF PRODUCT CERTIFICATION

證書號碼： CI335065676204 號 99
Certificate No.

茲據 康舒科技股份有限公司
定，准予登錄並使用商品安全標章  及識別號碼：
The application made by

申請驗證登錄，經審查結果符合規
R33567 。其登錄事項如下：
for Registration of Product

Certification has been reviewed and found to be in compliance with related regulations. Therefore, registration is granted with the
Product Safety Mark  and the Identification No. R33567 . Details of the registration are follows :

申請人：康舒科技股份有限公司
Applicant

統一編號：12341051
Uniform No.

地址：台北市松山區南京東路五段99號11樓
Address

生產廠場：詳如附表
Factory

廠址：詳如附表
Factory Address

商品種類名稱：
Type/name of product

商品分類號列：8504.40.91.00.7-A
C.C.C Code

中文名稱：交換式電源供應器
Chinese name

英文名稱：SWITCHING POWER SUPPLY
English name

型式：FSF050
Type

系列型式：R1CA2122A(以下空白)
Series of the type

依據標準：CNS13438 (095/06/01年版)、CNS14336-1 (099/09/30年版)、符合CNS 15663
Standards 第5節「含有標示」規定。(102年版)

標準檢驗局發證(發證地址：100臺北市中正區濟南路1段4號)

This certificate is issued by the BSMI. (No.4, Sec. 1, Jinan Rd., Zhongzheng Dist., Taipei City 100, Taiwan)

本證書以電子文件行之，所載內容若有不符之處，以標準局電腦資料為主，查詢驗證資料
網址：<http://bsmi.gov.tw>

登錄日期：中華民國	105	年	12	月	23	日
Registration Date	2016	(year)	12	(month)	23	(day)
本證書有效期限至	111	年	12	月	22	日
Expiration Date	2022	(year)	12	(month)	22	(day)
發證日期：中華民國	108	年	10	月	01	日
Date of issue	2019	(year)	10	(month)	01	(day)



註1：持本證書進口驗證登錄商品時，進口人須與本證書名義人相同。

註2：次年度商品驗證登錄年費繳納期限為當年11月30日，逾期未繳納者，經限期繳納屆期未繳納，即依商品檢驗法第42條第7款規定廢止驗證登錄，並自次年度1月1日起生效。

經濟部標準檢驗局
BUREAU OF STANDARDS, METROLOGY AND INSPECTION,
MINISTRY OF ECONOMIC AFFAIRS

商品驗證登錄電子證書
CERTIFICATE OF THE REGISTRATION OF PRODUCT CERTIFICATION

證書號碼： CI335065676204 號 99
Certificate No.

- 生產廠場： 1. Acbel Polytech Inc.
Factory： No. 159, Sec. 3, Danjin Rd., Tamsui Dist., New Taipei City 251, Taiwan, R.O.C.
2. Acbel Polytech (Philippines) Inc.
No. 2 Tagaytay Ridge Drive, Carmelray Industrial Park II, Km. 54 National Highway, Calamba City, Laguna 4027, Philippines
3. ACBEL ELECTRONIC (WUHAN) CO., LTD
No. 1, Du Tai North Road Economic Development Zone XianTao City, Hubei Province P.R. China
4. AcTel Electronic (Dong Guan) Co., Ltd.
No. 13-16, Hong Yeh 11 Rd. Hong Yeh Industrial District Tang Xia Town, Dong Guan City, Guang Dong P.R. China
5. AcBel Electronic (Dong guan) Co., Ltd.
No.17-28, Hong Yeh Road, Hong Yeh Ind. District, Tang Xia Town, DongGuan, Guangdong, 523710 P.R. China

(以下空白)





中国国家强制性产品认证证书

证书编号：2016010907919108

认证委托人名称及地址

康舒科技股份有限公司
台北市松山区南京东路5段99号11楼

生产者名称及地址

康舒科技股份有限公司
台北市松山区南京东路5段99号11楼

生产企业名称及地址

康舒电子(东莞)有限公司
中国广东省东莞市塘厦镇宏业工业区宏业大道17-28号

产品名称和系列、型号、规格

开关电源

FSF050, R1CA2122A 1)输入:100-127V~, 50/60Hz, 10A.; 输出: DC +12V/66.7A, +12Vsb/3A
最大总功率 800W。 2)输入:200-240V~, 50/60Hz, 8A 或 DC240V, 6A MAX. 输出: DC
+12V/100A, +12Vsb/3A 最大总功率 1200W。 (不带电线组件销售, 仅适用于海拔 5000 米及以
下)

产品标准和技术要求

GB 17625.1-2022 (A类); GB 4943.1-2022; GB/T 9254.1-2021 (A级)

上述产品符合《强制性产品认证实施规则 电子产品及安全附件》
(CNCA-C09-01:2023)的要求, 特发此证。

发证日期: 2024年02月27日 有效期至: 2026年09月28日

本证书为变更证书, 证书首次颁发日期: 2016年11月11日
证书信息和有效性可扫描下方二维码或登录发证机构网站查验,
也可在认监委网站 (www.cnca.gov.cn) 查询。

经中国合格评定国家认可委员会认可 CNAS C001-P



签发:

谢肇煦



中国质量认证中心
CHINA QUALITY CERTIFICATION CENTRE



中国质量认证中心



CERTIFICATE FOR CHINA COMPULSORY PRODUCT CERTIFICATION

本翻译文件不具有法律效力，
不得单独使用
This translated document
does not have legal validity and
cannot be used in isolation

CERTIFICATE NO.: 2016010907919108

NAME AND ADDRESS OF THE APPLICANT

Acbel Polytech Inc.
11F., No.99, Sec. 5, Nan-King E. Road, Sungshan Chiu, Taipei, Taiwan, Province Of China.

NAME AND ADDRESS OF THE MANUFACTURER

Acbel Polytech Inc.
11F., No.99, Sec. 5, Nan-King E. Road, Sungshan Chiu, Taipei, Taiwan, Province Of China.

NAME AND LOCATION OF THE FACTORY

Acbel Electronic (Dong Guan) Co., Ltd.
No. 17-28, Horng Yeh Road, Horng Yeh Industrial District, Tang Xia Town, Dong Guan City, Guang
Dong Province, China

PRODUCT NAME,MODEL AND SPECIFICATION

Switching Power Supply

FSF050 ,R1CA2122A 1)I/P: 100-127V ~ , 50/60Hz, 10A; O/P: DC +12V/66.7A, +12Vsb/3A ,Total power 800W MAX.
2)I/P: 200-240V ~ , 50/60Hz, 8A or DC 240V,6A MAX. O/P: DC +12V/100A, +12Vsb/3A Total power 1200W MAX.
(Sales without Power Cord Set. Altitude up to 5000m)

STANDARDS AND TECHNICAL REQUIREMENTS FOR THE PRODUCTS

GB 17625.1-2022(Class A);GB 4943.1-2022;GB/T 9254.1-2021(Class A)

This is to certify that the above mentioned product(s) complies with the requirements of
implementation rules for compulsory certification(REFNO. CNCA-C09-01:2023).

Valid from: Feb.27,2024

Valid until: Sep.28,2026

Date of original issued: Nov.11,2016

The certificate information and validity could be checked by scanning the QR code below or logging in to
the website of the issuing authority, or on the website of the CNCA (www.cnca.gov.cn).

Accredited by China National Accreditation Service for Conformity Assessment CNAS C001-P



SIGNATURE:

谢肇煦



中国质量认证中心
CHINA QUALITY CERTIFICATION CENTRE



CHINA QUALITY CERTIFICATION CENTRE



中国国家强制性产品认证证书

证书编号: 2016010907919108

委托人名称、地址

康舒科技股份有限公司
新北市淡水区淡金路3段159号

生产者(制造商)名称、地址

康舒科技股份有限公司
新北市淡水区淡金路3段159号

生产企业名称、地址

康舒电子(东莞)有限公司
广东省东莞市塘厦镇宏业工业区宏业大道17-28号

产品名称和系列、规格、型号

开关电源

FSF050, R1CA2122A 1)输入:100-127V~, 50/60Hz, 10A.; 输出: DC +12V/66.7A, +12Vsb/3A 最大总功率 800W。 2)输入:200-240V~, 50/60Hz, 8A 或DC240V, 6A MAX. 输出: DC +12V/100A, +12Vsb/3A 最大总功率1200W。(不带电线组件销售, 仅适用于海拔5000米及以下)

产品标准和技术要求

GB4943.1-2011; GB17625.1-2012; GB9254-2008 (Class A)

上述产品符合强制性产品认证实施规则
CNCA-C09-01:2014的要求, 特发此证。

发证日期: 2016年11月11日

有效期至: 2021年11月11日

证书有效期内本证书的有效性依据发证机构的定期监督获得保持。

本证书的相关信息可通过国家认监委网站www.cncal.gov.cn查询



主任:

中国质量认证中心

中国·北京·南四环西路188号9区100070

<http://www.cqc.com.cn>



Q 1379505



CERTIFICATE FOR CHINA COMPULSORY PRODUCT CERTIFICATION

No. : 2016010907919108

NAME AND ADDRESS OF THE APPLICANT

Acbel Polytech Inc.
No.159, Sec. 3, Danjin Rd., Tamsui Dist., New Taipei City 251, Taiwan

NAME AND ADDRESS OF THE MANUFACTURER

Acbel Polytech Inc.
No.159, Sec. 3, Danjin Rd., Tamsui Dist., New Taipei City 251, Taiwan

NAME AND ADDRESS OF THE FACTORY

Acbel Electronic (Dong Guan) Co., Ltd.
No. 17-28, Horng Yeh Road, Horng Yeh Ind. District, Tang Xia Town, Dong guan, Guangdong 523710, P.R., China

NAME, MODEL AND SPECIFICATION

Switching Power Supply

FSF050, R1CA2122A 1) I/P: 100-127V~, 50/60Hz, 10A; O/P: DC +12V/66.7A, +12Vsb/3A, Total power 800W MAX. 2) I/P: 200-240V~, 50/60Hz, 8A or DC 240V, 6A MAX. O/P: DC +12V/100A, +12Vsb/3A Total power 1200W MAX. (Sales without Power Cord Set. Altitude up to 5000m)

THE STANDARDS AND TECHNICAL REQUIREMENTS FOR THE PRODUCTS

GB4943.1-2011;GB17625.1-2012;GB9254-2008(Class A)

This is to certify that the above mentioned products have met the requirements of implementation rules for compulsory certification(REF NO. CNCA-C09-01:2014).

Date of issue: Nov.11,2016 Date of expiry: Nov.11,2021

Validity of this certificate is subject to positive result of the regular follow up inspection by issuing certification body until the expiry date.

This certificate can be verified through CNCA's website: www.cnca.gov.cn



President:

Wang Kejiao



CHINA QUALITY CERTIFICATION CENTRE

Section 9, No.188, Nansihuan Xilu, Beijing 100070 P.R.China

<http://www.cqc.com.cn>

Q 1379505

Declaration of Conformity

For the following equipment :

Product : Switching Power Supply
Type Designation : FSF050,R1CA2122A
Trademark : 
Manufacturer's Name : ACBEL POLYTECH INC
Manufacturer's Address : No. 159, Sec. 3, Tam-King Road, Tamsui Taipei, Taiwan

Is herewith confirmed to comply with the following legal requirements set out in the Official Journal of the European Union. Products sold in the European Economic Area (EEA) have been assessed to meet high safety, health, and environmental protection requirements.

- Low-Voltage Directive 2014/35/EU : EN 60950-1:2006+A11:2009+A1:2010+A12:2011+A2:2013
- EMC Directive 2014/30/EU : EN 55022:2010/AC:2011 ; EN 55024:2010 ; EN 61000-3-2:2006+A1:2009+A2:2009 ; EN 61000-3-3:2008
- ErP Directive : Regulation (EC) No. 278/2009 EN 50563:2011/A1:2013
- RoHS Directive (2011/65/EU) : EN 50581:2012
- Additional information : DECISION No 768/2008/EC

Responsible for making this declaration is the :

- Manufacturer
 Authorized representative established within the EU
 Authorized representative established within the EU (if applicable) :

Company Name : _____
Company Address : _____

Person responsible for making this declaration

Name , Surname : Vincent Hsieh
Position / Title : Safety Supervisor / Acbel Polytech Inc.

Taipei , Taiwan
Place

2016-12-14
Date

Vincent Hsieh
Legal Signature



भारतीय मानक ब्यूरो

(उपभोक्ता मामले, खाद्य एवं सार्वजनिक वितरण विभाग, भारत सरकार)

BUREAU OF INDIAN STANDARDS

(Ministry of Consumer Affairs, Food & Public Distribution, Govt. of India)

मानक भवन, 9 बहादुर शाह जफर मार्ग, नई दिल्ली - 110002

Manak Bhavan, 9 Bahadur Shah Zafar Marg, New Delhi - 110002

दूरभाष/Phone: +91-11-23230856 23230101 31 23233375 23239402

ई-मेल/E-mail: registration@bis.org.in

वेबसाइट/Website: <http://www.bis.gov.in>, <http://crisbis.in>, <http://bis.org.in>

Our Ref: Registration/CRS 2015-0272/R-41013579

Date:17-02-2017

Inclusion Id: 8799

Subject :Inclusion of Additional Model(s)

MANUFACTURING UNIT :	ACBEL ELECTRONICS (DONG GUAN) CO LTD HORNG YEH INDUSTRIAL DISTRICT TANG XIA TOWN, DONGGUAN, GUANGDONG, CHINA
INDIAN REPRESENTATIVE :	Ms. RUMA DAS 62B, VIJAY PARK, NAYA BAZAR NAJAFGARH, DELHI, INDIA shona.das11@gmail.com 9818468801

Dear Sir,

1. This has reference to your request for inclusion of models of 'Power Adapter for IT Equipment' as per IS 13252(PART 1):2010 / IEC 60950-1 : 2005 in Registration No. R-41013579 already granted to you which is valid upto 15-04-2017.

2. It is intimated that the additional Models as per details given below have been agreed to be included in your Registration No. R-41013579 w.e.f. 16-02-2017:

Product	Power Adapter for IT Equipment
IS No.	IS 13252(PART 1):2010 / IEC 60950-1 : 2005
Brand	ACBEL
Inclusion of Additional Models (w.e.f. 16-02-2017)	FSD062, FSF050, R1CA2122A
Factory Address	HORNG YEH INDUSTRIAL DISTRICT TANG XIA TOWN, DONGGUAN, GUANGDONG, CHINA

3. In view of the above, you are permitted to mark your product 'Power Adapter for IT Equipment' having above mentioned Brand/Additional Models as per the guidelines for the use of Standard Mark and labelling requirements under BIS Compulsory Registration Scheme for Electronic and IT Products given in circular No. Ref: CMD 3/8:1/6975 dated 03/12/2015 available on BIS website and Ministry of Electronics and Information Technology (MeitY) notification S. O. 638(E) dated 10/02/2016, w.e.f. 16-02-2017. Other terms and conditions of the Registration Scheme shall remain same.

4. This letter is being issued with the approval of competent authority. Kindly acknowledge receipt of this letter.

Thanking you,

Yours faithfully,

(M.A.J. VINOD)

Scientist-E(Reg. Deptt.)

Telefax : +91-11-23230856

E-mail: registration@bis.org.in



भारतीय मानक ब्यूरो

(उपभोक्ता मामले, खाद्य एवं सार्वजनिक वितरण मंत्रालय, भारत सरकार)

BUREAU OF INDIAN STANDARDS

(Ministry of Consumer Affairs, Food & Public Distribution,
Govt. of India)

मानक भवन, 9 बहादुर शाह जफ़र मार्ग, नई दिल्ली - 110002
Manak Bhavan, 9 Bahadur Shah Zafar Marg, New Delhi - 110002
दूरभाष/Phone: +91-11-23230856/2323010131/23233375/23239402
ई-मेल/E-mail: registration@bis.gov.in
वेबसाइट/Website: <https://bis.gov.in/>, <https://www.crsbis.in/BIS/>

Our Ref: REGISTRATION /CRS-2015-0272/R-41013579

Dated: 2024-03-12
17:54:20

RENEWAL ID : 24954

Subject : RENEWAL OF LICENCE R-41013579 AS PER IS 13252(Part 1):2010/ IEC 60950-1 : 2005

Acbel Electronics (Dong Guan) Co Ltd
HORNG YEH INDUSTRIAL DISTRICT TANG XIA TOWN DONGGUAN GUANGDONG CHINA
GUANGDONG, China, 0



Dear Sir/Madam,

With reference to your online application dated 12-03-2024 for renewal of the above mentioned licence; this is to inform you that the same has been renewed from **16-04-2024 to 15-04-2029**.

It may be noted that the said licence granted under clause (b) of sub section (2) of section 13 of the Act shall *expire* at the end of the period for which it is granted unless renewed or its renewal is deferred. You are, therefore, requested to apply for next renewal to BIS within three months before the expiration of the licence.

Thanking you.

Yours faithfully,

Registration Department
Bureau of Indian Standards,
9, Bahadur Shah Zafar Marg,
New Delhi-110002.
Telfax : +91-11-23230856
E-mail: registration@bis.gov.in

Note: This is a system generated letter. Hence signature is not required.
To verify authentication of letter, kindly scan the QR code on this letter.

For details information on BIS, consult the e-BIS Portal (www.manakonline.in).
Please use BIS CARE APP for verification of ISI-marked goods and hallmarked gold jewellery.



접수번호 : 20161104-0048

안전확인신고증명서 Confirmation Letter of Declaration

신고번호: XU100121-16165A 유효기간 만료일: 2026.12.21
 (Application No.) (Validity Period)
 신고업체명: Acbel Electronic (Dongguan) Co.,Ltd.
 (Applicant)
 대표자명: David Kao
 (President)
 소재지: No.17-28 (Hong Yeh Rd) Hong Yeh Industrial District, Tang Xia Town,
 (Address) Dongguan, Guangdong, China
 제품명: 컴퓨터용 전원공급장치
 (Product)
 기본모델명: FSF050
 (Basic Model)
 제품정격: I/P:200-240V 50/60Hz 8.0A or DC 240V 6A (O/P: DC + 12.0V/ 100A,
 (Rating) + 12Vsb/ 3.0A TOTAL POWER 1200W MAX)
 파생모델명 (Series Model):
 R1CA2122A

안전기준: K 60950-1(2.0)(2011-12)
(Standard)

본 확인신고는 제조국 : 중국
 제조업자: Acbel Electronic (Dongguan) Co.,Ltd.

다수의 공장: [별첨]의 제품에 한함

「전기용품안전 관리법 시행규칙」 제19조제3항에 따라 위의 전기용품에 대하여 안전확인신고증명서를 발급합니다.
We issue this Confirmation Letter of Declaration of the Safety Confirmation for the above electrical appliance in accordance with Article 19(3) of the Enforcement Rule of the Electrical Appliances Safety Control Act.



2016 년 12 월 22 일
(Year) (Month) (Day)

한국기계전자시험연구원 Korea Testing Certification



※ 이 신고증명서는 「전기용품안전 관리법」에 따른 전기용품 안전성 확인에 한정된 것이며, 그 밖의 다른 법률이 적용되는 제품의 경우에는 해당 법률에 따라 추가로 인증·허가 등을 받아야 합니다.

- 첨부서류
1. 안전관리부품 및 재질목록 (List of Critical Components)
 2. 기본모델·파생모델의 내용 (Descriptions of the basic and series model)
 3. 안전확인신고 내용의 변경 현황 (Revisions Status)



[별첨]

다수의 공장 현황(The status of Multiple Factories)

No	현황	
1	다수의 공장의 명(Name) 주소(Address)	Acbel Electronic (Wuhan) Co., Ltd. No.1, DuTai North Road, Economic Development Zone, XianTao City, HuiBei China
	제조국명(Origin)	중국

Acbel Polytech Inc.
Mr. Vincent Hsieh Deputy Manager
Safety. DQ Dept.
No. 159, Sec. 3, Danjin Rd.,
Tamsui Dist., New Taipei City 251
Taiwan

Date : 11.11.2016
Our ref. : KKC ZTW1
Your ref.: T160566_Evonne

Ref : R TÜV-Mark Approval

Type of Equipment : Switching Power Supply
Model Designation : See Certificate
Certificate No. : R 50361637 0001
Report No. : 10057850 001

Dear Mr. Vincent Hsieh,

The above specified equipment has been tested and found to be in accordance with the relevant requirements.

Please find enclosed your certificate as specified above.

If cancellation of the certificate is submitted by 15 November in a given year, no fee will be charged for the following year.

The certificate is issued with the reservation that the license holder applies all information required in § 6 of the ProdSG related to name and address of the manufacturer or his authorized representative / importer, including their respective contact addresses on the product prior to marketing of the product in the European Economic Area.

With kind regards,

Certification Body

Dipl.-Ing. E. Stoelzel

Enclosure

TÜV RHEINLAND TAIWAN LTD.

11F., No. 758, Sec. 4, Bade Rd.,
Songshan Dist., Taipei City 105,
Taiwan R. O. C.
Tel. (02) 2172-7000
Fax (02) 2528-0018
<http://www.tuv.com>

TAICHUNG BRANCH:

No. 9, Lane 36, Sec. 3, Minsheng Rd.,
Daya Dist., Taichung City 428
Taiwan, R. O. C.
Tel. (04) 2560-2998
Fax (04) 2566-3598

Zertifikat

Certificate



Zertifikat Nr. *Certificate No.*
R 50361637

Blatt *Page*
0001

Ihr Zeichen *Client Reference*
T160566_Evonne

Unser Zeichen *Our Reference*
ZTW1-KKC-10057850 001

Ausstellungsdatum *Date of Issue*
11.11.2016 (day/mo/yr)

Genehmigungsinhaber *License Holder*
Acbel Polytech Inc.
No. 159, Sec. 3, Danjin Rd.,
Tamsui Dist., New Taipei City 251
Taiwan

Fertigungsstätte *Manufacturing Plant*
Acbel Polytech Inc.
No. 159, Sec. 3, Danjin Rd.,
Tamsui Dist., New Taipei City 251
Taiwan

Prüfzeichen *Test Mark*



Regelmäßige
Produktions-
überwachung
Sicherheit
Bauart geprüft

www.tuv.com
ID 1419040969

Geprüft nach *Tested acc. to*

EN 60950-1:2006+A11+A1+A12+A2

Zertifiziertes Produkt (Geräteidentifikation)
Certified Product (Product Identification)

Lizenzentgelte - Einheit
License Fee - Unit

Einbau-Schaltnetzteil (Switching Power Supply)

Bezeichnung (Type Designation): FSP050(AcBel) 10
Nennspannung : 1) AC 100-127V, 50/60Hz
(Rated Voltage) 2) AC 200-240V, 50/60Hz oder (or) DC 240V
Nennstrom : 1) 10.0A
(Rated Current) 2) 8.0A oder (or) 6A MAX
Ausgang : 1) DC +12.0V/66.7A, +12Vsb/3.0A
(Output) 2) DC +12.0V/100A, +12Vsb/3.0A
max. Ausgangsleistung (max. Output Power): 1) 800W, 2) 1200W
max. Umgebungstemperatur (max. Ambient Temperature): 50°C
Schutzklasse (Protection Class) : I
max. Betriebshöhe (max. Operating Altitude) : 5,000m
Verschmutzungsgrad (Pollution Degree) : 2
Vermerke: Primär- und Sekundärkreise sind gemäß Verfahren 1
nach Abschnitt 2.9.4 getrennt. Der Einbau muß gemäß der
zugehörigen Einbauanweisung erfolgen. (Remarks: Primary and
secondary circuits are separated according to method 1 of
clause 2.9.4. The installation has to be carried out
according to the attached installation instruction.)

10

ANLAGE (Appendix): 1

Dem Zertifikat liegt unsere Prüf- und Zertifizierungsordnung zugrunde und es bestätigt die Konformität des Produktes mit den oben genannten Standards und Prüfgrundlagen. Zusätzliche Anforderungen in Ländern, in denen das Produkt in Verkehr gebracht werden soll, müssen zusätzlich betrachtet werden. Die Herstellung des zertifizierten Produktes wird überwacht.
This certificate is based on our Testing and Certification Regulation and states the conformity of the product with the standards and testing requirements as indicated above. Any additional requirements in countries where the product is going to be marketed have to be considered additionally. The manufacturing of the certified product is subject to surveillance.

TÜV Rheinland LGA Products GmbH, Tillystraße 2, 90431 Nürnberg

Tel.: +49 221 806-1371 e-mail: cert-validity@de.tuv.com
Fax: +49 221 806-3935 http://www.tuv.com/safety

Zertifizierungsstelle

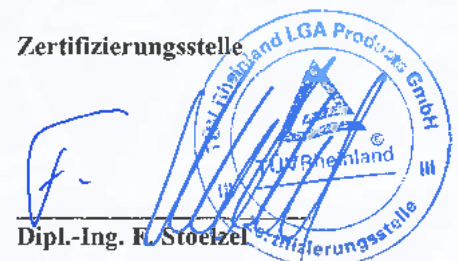

Dipl.-Ing. F. Stöelzel

Zertifikat

Certificate



Zertifikat Nr. *Certificate No.*
R 50361637

Blatt *Page*
0002

Ihr Zeichen *Client Reference*
T160566_Evonne

Unser Zeichen *Our Reference*
ZTW1-KKC-10057850 001

Ausstellungsdatum *Date of Issue*
11.11.2016
(day/mo/yr)

Genehmigungsinhaber *License Holder*
Acbel Polytech Inc.
No. 159, Sec. 3, Danjin Rd.,
Tamsui Dist., New Taipei City 251
Taiwan

Fertigungsstätte *Manufacturing Plant*
Acbel Polytech Inc.
No. 159, Sec. 3, Danjin Rd.,
Tamsui Dist., New Taipei City 251
Taiwan

Prüfzeichen *Test Mark*



Regelmäßige
Produktions-
überwachung
Sicherheit
Bauart geprüft

www.tuv.com
ID 1419040969

Geprüft nach *Tested acc. to*
EN 60950-1:2006+A11+A1+A12+A2

Zertifiziertes Produkt (Geräteidentifikation)
Certified Product (Product Identification)

Lizenzentgelte - Einheit
License Fee - Unit

Einbau-Schaltnetzteil (Switching Power Supply)

wie Blatt (as page) 01

Ergänzung
(Addition)

Bezeichnung : R1CA2122A(AcBel)
(Type Designation)

1

1

ANLAGE (Appendix): 1

Dem Zertifikat liegt unsere Prüf- und Zertifizierungsordnung zugrunde und es bestätigt die Konformität des Produktes mit den oben genannten Standards und Prüfgrundlagen. Zusätzliche Anforderungen in Ländern, in denen das Produkt in Verkehr gebracht werden soll, müssen zusätzlich betrachtet werden. Die Herstellung des zertifizierten Produktes wird überwacht.
This certificate is based on our Testing and Certification Regulation and states the conformity of the product with the standards and testing requirements as indicated above. Any additional requirements in countries where the product is going to be marketed have to be considered additionally. The manufacturing of the certified product is subject to surveillance.

TÜV Rheinland LGA Products GmbH, Tillystraße 2, 90431 Nürnberg

Tel.: +49 221 806-1371 e-mail: cert-validity@de.tuv.com
Fax: +49 221 806-3935 http://www.tuv.com/safety

Zertifizierungsstelle

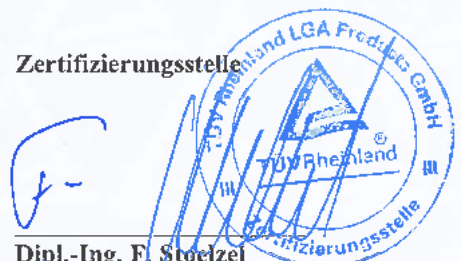

Dipl.-Ing. F. Stoezel

Zertifikat

Certificate



Zertifikat Nr. *Certificate No.*
R 50361637

Blatt *Page*
0003

Ihr Zeichen *Client Reference*
T160566_Evonne

Unser Zeichen *Our Reference*
ZTW1-KKC-10057850 001

Ausstellungsdatum *Date of Issue*
11.11.2016
(day/mo/yr)

Genehmigungsinhaber *License Holder*
Acbel Polytech Inc.
No. 159, Sec. 3, Danjin Rd.,
Tamsui Dist., New Taipei City 251
Taiwan

Fertigungsstätte *Manufacturing Plant*
Acbel Electronic (Dong Guan)
Co., Ltd.
No. 17-28, Horng Yeh Road, Horng
Yeh Ind. District, Tang Xia Town
Dongguan, Guangdong 523710
P.R. China

Prüfzeichen *Test Mark*



Regelmäßige
Produktions-
überwachung
Sicherheit
Bauart geprüft

www.tuv.com
ID 1419040989

Geprüft nach *Tested acc. to*
EN 60950-1:2006+A11+A12+A2

Zertifiziertes Produkt (Geräteidentifikation)
Certified Product (Product Identification)

Lizenzentgelte - Einheit
License Fee - Unit

Einbau-Schaltnetzteil (Switching Power Supply)

wie Blatt (as page) 01

Ergänzung
(Addition)

Fertigungsstätte: siehe oben
(Factory) (see above)

ANLAGE (Appendix): 1

Dem Zertifikat liegt unsere Prüf- und Zertifizierungsordnung zugrunde und es bestätigt die Konformität des Produktes mit den oben genannten Standards und Prüfgrundlagen. Zusätzliche Anforderungen in Ländern, in denen das Produkt in Verkehr gebracht werden soll, müssen zusätzlich betrachtet werden. Die Herstellung des zertifizierten Produktes wird überwacht.
This certificate is based on our Testing and Certification Regulation and states the conformity of the product with the standards and testing requirements as indicated above. Any additional requirements in countries where the product is going to be marketed have to be considered additionally. The manufacturing of the certified product is subject to surveillance.

TÜV Rheinland LGA Products GmbH, Tillystraße 2, 90431 Nürnberg

Tel.: +49 221 806-1371 e-mail: cert-validity@de.tuv.com
Fax: +49 221 806-3935 http://www.tuv.com/safety

Zertifizierungsstelle

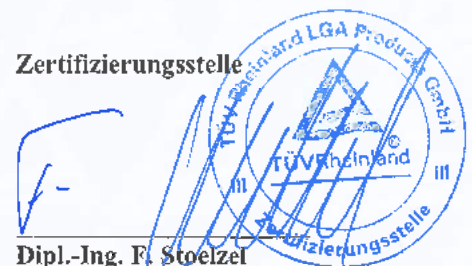

Dipl.-Ing. F. Stoelzel

Zertifikat

Certificate



Zertifikat Nr. *Certificate No.*
R 50361637

Blatt *Page*
0004

Ihr Zeichen <i>Client Reference</i>	Unser Zeichen <i>Our Reference</i>	Ausstellungsdatum	<i>Date of Issue</i>
T160566_Evonne	ZTW1-KKC-10057850 001	11.11.2016	(day/mo/yr)

Genehmigungsinhaber *License Holder*
Acbel Polytech Inc.
No. 159, Sec. 3, Danjin Rd.,
Tamsui Dist., New Taipei City 251
Taiwan

Fertigungsstätte *Manufacturing Plant*
AcTel Electronic (Dong Guan)
Co., Ltd.
No. 13-16, Hong Yeh 11Rd.
Hong Yeh Industrial District
Tang Xia Town
Dong Guan City, Guang Dong
P.R. China

Prüfzeichen *Test Mark*



Regelmäßige
Produktions-
überwachung
Sicherheit
Bauart geprüft

www.tuv.com
ID 1419040969

Geprüft nach *Tested acc. to*

EN 60950-1:2006+A11+A1+A12+A2

Zertifiziertes Produkt (Geräteidentifikation)
Certified Product (Product Identification)

Lizenzentgelte - Einheit
License Fee - Unit

Einbau-Schaltnetzteil (Switching Power Supply)

wie Blatt (as page) 01

Ergänzung
(Addition)

Fertigungsstätte: siehe oben
(Factory) (see above)

ANLAGE (Appendix): 1

Dem Zertifikat liegt unsere Prüf- und Zertifizierungsordnung zugrunde und es bestätigt die Konformität des Produktes mit den oben genannten Standards und Prüfgrundlagen. Zusätzliche Anforderungen in Ländern, in denen das Produkt in Verkehr gebracht werden soll, müssen zusätzlich betrachtet werden. Die Herstellung des zertifizierten Produktes wird überwacht.
This certificate is based on our Testing and Certification Regulation and states the conformity of the product with the standards and testing requirements as indicated above. Any additional requirements in countries where the product is going to be marketed have to be considered additionally. The manufacturing of the certified product is subject to surveillance.

TÜV Rheinland LGA Products GmbH, Tillystraße 2, 90431 Nürnberg

Tel.: +49 221 806-1371 e-mail: cert-validity@de.tuv.com
Fax: +49 221 806-3935 http://www.tuv.com/safety

Zertifizierungsstelle



Dipl.-Ing. F. Stoelzel

Zertifikat

Certificate



Zertifikat Nr. *Certificate No.*
R 50361637

Blatt *Page*
0005

Ihr Zeichen <i>Client Reference</i>	Unser Zeichen <i>Our Reference</i>	Ausstellungsdatum	<i>Date of Issue</i>
T160566_Evonne	ZTW1-KKC-10057850 001	11.11.2016	(day/mo/yr)

Genehmigungsinhaber *License Holder*
Acbel Polytech Inc.
No. 159, Sec. 3, Danjin Rd.,
Tamsui Dist., New Taipei City 251
Taiwan

Fertigungsstätte *Manufacturing Plant*
ACBEL ELECTRONIC (WUHAN) CO., LTD
No. 1, DuTai North Road
Economic Development Zone
XianTao City, HuBei Province
P.R. China

Prüfzeichen *Test Mark*



Regelmäßige
Produktions-
Überwachung
Sicherheit
Bauart geprüft

www.tuv.com
ID 1419040989

Geprüft nach *Tested acc. to*

EN 60950-1:2006+A11+A1+A12+A2

Zertifiziertes Produkt (Geräteidentifikation)
Certified Product (Product Identification)

Lizenzentgelte - Einheit
License Fee - Unit

Einbau-Schaltnetzteil (Switching Power Supply)

wie Blatt (as page) 01

Ergänzung
(Addition)

Fertigungsstätte: siehe oben
(Factory) (see above)

ANLAGE (Appendix): 1

Dem Zertifikat liegt unsere Prüf- und Zertifizierungsordnung zugrunde und es bestätigt die Konformität des Produktes mit den oben genannten Standards und Prüfgrundlagen. Zusätzliche Anforderungen in Ländern, in denen das Produkt in Verkehr gebracht werden soll, müssen zusätzlich betrachtet werden. Die Herstellung des zertifizierten Produktes wird überwacht.
This certificate is based on our Testing and Certification Regulation and states the conformity of the product with the standards and testing requirements as indicated above. Any additional requirements in countries where the product is going to be marketed have to be considered additionally. The manufacturing of the certified product is subject to surveillance.

TÜV Rheinland LGA Products GmbH, Tillystraße 2, 90431 Nürnberg

Tel.: +49 221 806-1371 e-mail: cert-validity@de.tuv.com
Fax: +49 221 806-3935 http://www.tuv.com/safety

Zertifizierungsstelle



Dipl.-Ing. F. Stoelzel

Zertifikat

Certificate



Zertifikat Nr. *Certificate No.*
R 50361637

Blatt *Page*
0006

Ihr Zeichen *Client Reference*
T160566_Evonne

Unser Zeichen *Our Reference*
ZTW1-KKC-10057850 001

Ausstellungsdatum *Date of Issue*
11.11.2016 (day/mo/yr)

Genehmigungsinhaber *License Holder*
Acbel Polytech Inc.
No. 159, Sec. 3, Danjin Rd.,
Tamsui Dist., New Taipei City 251
Taiwan

Fertigungsstätte *Manufacturing Plant*
Acbel Polytech(Philippines) INC.
No. 2 Tagaytay Ridge Drive,
Carmelray Industrial Park II,
Km. 54 National Highway,
Calamba City, Laguna 4027
Philippines

Prüfzeichen *Test Mark*



Regelmäßige
Produktions-
überwachung
Sicherheit
Bauart geprüft

www.tuv.com
ID 1419040969

Geprüft nach *Tested acc. to*
EN 60950-1:2006+A11+A1+A12+A2

**Zertifiziertes Produkt (Geräteidentifikation)
*Certified Product (Product Identification)***

**Lizenzentgelte - Einheit
*License Fee - Unit***

Einbau-Schaltnetzteil (Switching Power Supply)

wie Blatt (as page) 01

Ergänzung
(Addition)

Fertigungsstätte: siehe oben
(Factory) (see above)

ANLAGE (Appendix): 1

Dem Zertifikat liegt unsere Prüf- und Zertifizierungsordnung zugrunde und es bestätigt die Konformität des Produktes mit den oben genannten Standards und Prüfgrundlagen. Zusätzliche Anforderungen in Ländern, in denen das Produkt in Verkehr gebracht werden soll, müssen zusätzlich betrachtet werden. Die Herstellung des zertifizierten Produktes wird überwacht.
This certificate is based on our Testing and Certification Regulation and states the conformity of the product with the standards and testing requirements as indicated above. Any additional requirements in countries where the product is going to be marketed have to be considered additionally. The manufacturing of the certified product is subject to surveillance.

TÜV Rheinland LGA Products GmbH, Tillystraße 2, 90431 Nürnberg

Tel: +49 221 806-1371 e-mail: cert-validity@de.tuv.com
Fax: +49 221 806-3935 http://www.tuv.com/safety

Zertifizierungsstelle



Dipl.-Ing. F. Stoezel



FCC Verification Test Report

Applicant : AcBel Polytech Inc.
Address : No. 159, Sec. 3, Danjin Rd., Tamsui Dist.,
New Taipei City 251, Taiwan, R.O.C.
Equipment : SWITCHING POWER SUPPLY
Model No. : FSF050, R1CA2122A
Trade Name : 

I HEREBY CERTIFY THAT :

The sample was received on Oct. 14, 2016 and the testing was carried out on Oct. 17, 2016 at CerpPASS Technology Corp. The test result refers exclusively to the test presented test model / sample. Without written approval of CerpPASS Technology Corp., the test report shall not be reproduced except in full.

Approved by:

Ray Chou / Assistant Manager

Laboratory Accreditation:

CerpPASS Technology Corporation Test Laboratory



CerpPASS Technology(SuZhou) Co., Ltd.





Contents

1. Summary of Test Procedure and Test Result.....	4
1.1. Applicable Standards	4
2. Test Configuration of Equipment under Test	5
2.1. Feature of Equipment under Test.....	5
2.2. Test Manner	5
2.3. Description of Test System.....	5
2.4. General Information of Test.....	6
2.5. Measurement Uncertainty	6
3. Test of Conducted Emission.....	7
3.1. Test Limit	7
3.2. Test Procedures	7
3.3. Typical test Setup.....	8
3.4. Measurement Equipment.....	8
3.5. Test Result and Data.....	9
3.6. Test Photographs	11
4. Test of Radiated Emission	12
4.1. Test Limit	12
4.2. Test Procedures	13
4.3. Typical test Setup.....	13
4.4. Measurement Equipment.....	14
4.5. Test Result and Data (30MHz ~ 1GHz).....	15
4.6. Test Photographs (30MHz ~ 1GHz).....	17



1. Summary of Test Procedure and Test Result

1.1. Applicable Standards

FCC

The measurements shown in this test report were made in accordance with the procedures given in ANSI C63.4 – 2014 and the energy emitted by this equipment was passed Part 2, Part 15, CISPR PUB. 22.

Canada

The measurements shown in this test report were made in accordance with the procedures given in Canada ICES-003 issue 6 section 3.a and 3.b.

The energy emitted by this equipment was passed both Radiated and Conducted Emissions Class **A** limits.

Test Item	Normative References	Test Result
Conducted Emission	ANSI C63.4-2014, FCC Part 15 Subpart B, KDB17416 Canada ICES-003 Issue 6	PASS
Radiated Emission	ANSI C63.4-2014 FCC Part 15 Subpart B, KDB17416 Canada ICES-003 Issue 6	PASS



2. Test Configuration of Equipment under Test

2.1. Feature of Equipment under Test

INPUT	100-127Vac~, 50/60Hz, 10.0A		200-240Vac~, 50/60Hz, 8.0A 240Vdc, 6.0A MAX.	
DC OUTPUT	+12.0V	+12Vsb	+12.0V	+12Vsb
	66.7A	3.0A	100A	3.0A
TOTAL POWER	800W MAX.		1200W MAX.	

2.2. Test Manner

- During testing, the interface cables and equipment positions were varied according to ANSI C63.4.
- The complete test system included remote workstation, Case, Dummy Load, Multi-Meter and EUT for the EMI test. The remote workstation included DC Source.
- During the test, connect the Load and EUT, make the EUT in Full load.
- The test modes of conduction test as follow:
 - Test Mode 1. AC 120V, AC Mode, For Load in case
 - Test Mode 2. AC 240V, AC Mode, For Load in case
 caused "Test Mode 1" generated the worst case, it was reported as the final data.
- The test modes of radiation test as follow:
 - Test Mode 1. AC 120V, AC Mode, For Load in case
 - Test Mode 2. AC 240V, AC Mode, For Load in case
 - Test Mode 3. DC Mode, For Load in case
 caused "Test Mode 1" generated the worst case, it was reported as the final data.
- The maximum operating frequency is under 108MHz, the test frequency range is from 30MHz to 1GHz.

2.3. Description of Test System

Device	Manufacturer	Model No.	Description
Case	AcBel	N/A	N/A
Dummy Load	AcBel	N/A	N/A
Multi-Meter	GW	GDM-357	Probe Cable, Unshielding 0.5m
Remote workstation			
DC Source	GITEK	GR-30H10H	N/A



2.4. General Information of Test

<input checked="" type="checkbox"/> Test Site	Cerpass Technology Corporation Test Laboratory Address: No.10, Ln. 2, Lianfu St., Luzhu Dist., Taoyuan City 33848, Taiwan (R.O.C.) Tel:+886-3-3226-888 Fax:+886-3-3226-881 Address: No.68-1, Shihbachongsi, Shihding Township, New Taipei City 223, Taiwan, R.O.C. Tel: +886-2-2663-8582	
	FCC	TW1079, TW1061, 390316, 228391, 641184
	IC	4934E-1, 4934E-2
	VCCI	T-2205 for Telecommunication Test C-4663 for Conducted emission test R-4218 for Radiated emission test G-812, G-813 for radiated disturbance above 1GHz
<input type="checkbox"/> Test Site	Cerpass Technology (Suzhou) Co.,Ltd Address: No.66,Tangzhuang Road, Suzhou Industrial Park, Jiangsu 215006, China Tel: +86-512-6917-5888 Fax: +86-512-6917-5666	
	FCC	916572, 331395
	IC	7290A-1, 7290A-2
	VCCI	T-1945 for Telecommunication Test C-2919 for Conducted emission test R-2670 for Radiated emission test G-227 for radiated disturbance above 1GHz
Frequency Range Investigated:	Conducted: from 150 kHz to 30 MHz Radiation: from 30 MHz to 1,000 MHz	
Test Distance :	The test distance of radiated emission below 1GHz from antenna to EUT is 10 M. The test distance of radiated emission above 1GHz from antenna to EUT is 3 M.	

2.5. Measurement Uncertainty

Measurement Item	Measurement Frequency	Polarization	Uncertainty
Conducted Emission	9 kHz ~ 30 MHz	LINE / NEUTRAL	± 3.25 dB
Radiated Emission	30 MHz ~ 1,000 MHz	Vertical / Horizontal	± 3.93 dB
	1,000 MHz ~ 6,000 MHz	Vertical / Horizontal	± 4.01 dB
	6,000 MHz ~ 18,000 MHz	Vertical / Horizontal	± 4.72 dB

The measurement uncertainty will be considered, when test result margin to the limit.



3. Test of Conducted Emission

3.1. Test Limit

Conducted Emissions were measured from 150 kHz to 30 MHz with a bandwidth of 9 KHz, according to the methods defined in ANSI C63.4-2014. The EUT was placed on a nonmetallic stand in a shielded room 0.8 meters above the ground plane. The interface cables and equipment positioning were varied within limits of reasonable applications to determine the position produced maximum conducted emissions.

For a Class A digital device that is designed to be connected to the public utility (AC) power line, the radio frequency voltage that is conducted back onto the AC power line on any frequency or frequencies within the band 150 kHz to 30 MHz shall not exceed the limits in the following table, as measured using a 50 μ H/50 ohms LISN. Compliance with the provisions of this paragraph shall be based on the measurement of the radio frequency voltage between each power line and ground at the power terminal. The lower limit applies at the boundary between the frequency ranges.

Table 1 Conducted Emission Limits (dB μ V):

Frequency range (MHz)	Class A Equipment		Class B Equipment	
	Quasi Peak	Average	Quasi Peak	Average
0.15 to 0.50	79	66	66 to 56*	56 to 46*
0.50 to 5	73	60	56	46
5. to 30.	73	60	60	50

*The limit decreases linearly with the logarithm of the frequency in the range 0.15 MHz to 0.5MHz.

3.2. Test Procedures

- The EUT was placed 0.4 meter from the conducting wall of the shielding room was kept at least 80 centimeters from any other grounded conducting surface.
- Connect EUT to the power mains through a line impedance stabilization network (LISN).
- All the support units are connecting to the other LISN.
- The LISN provides 50 ohm coupling impedance for the measuring instrument.
- The FCC states that a 50 ohm, 50 micro-Henry LISN should be used.
- Both sides of AC line were checked for maximum conducted interference.
- The frequency range from 150 kHz to 30 MHz was searched.
- Set the test-receiver system to Peak Detect Function and Specified Bandwidth with Maximum Hold Mode.



3.3. Typical test Setup

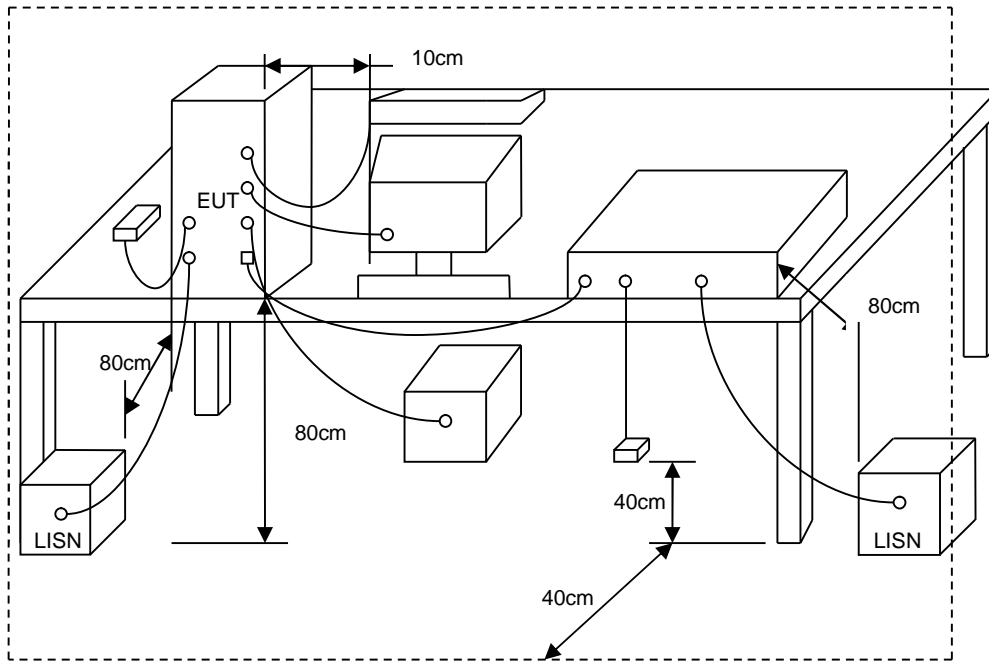

3.4. Measurement Equipment

Instrument	Manufacturer	Model No.	Serial No.	Calibration Date	Valid Date
EMI Receiver	R&S	ESCI3	101423	2016/04/08	2017/04/07
LISN	Schwarzbeck	NSLK 8127	8127-740	2016/08/30	2017/08/29
Pulse Limiter	R&S	ESH3-Z2	101933	2016/08/29	2017/08/28
Software	Farad	Ez-EMC	ver.ct3a1	N/A	N/A



3.5. Test Result and Data

Power	: AC 120V	Pol/Phase	: LINE
Test Mode	: Mode 1	Temperature	: 24°C
Test Date	: Oct. 14, 2016	Humidity	: 51%

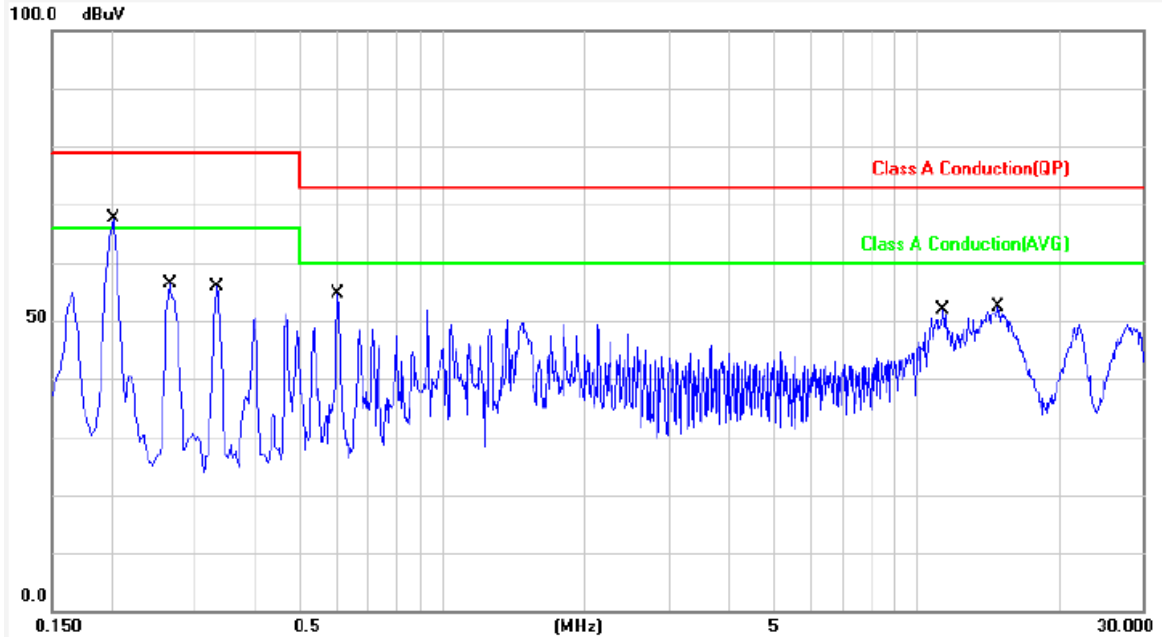

No.	Frequency (MHz)	Factor (dB)	Reading (dBuV)	Level (dBuV)	Limit (dBuV)	Margin (dB)	Detector	P/F
1	0.2010	9.97	55.95	65.92	79.00	-13.08	QP	P
2	0.2010	9.97	51.10	61.07	66.00	-4.93	AVG	P
3	0.2660	9.97	50.23	60.20	79.00	-18.80	QP	P
4	0.2660	9.97	42.80	52.77	66.00	-13.23	AVG	P
5	0.3339	9.96	44.40	54.36	79.00	-24.64	QP	P
6	0.3339	9.96	39.20	49.16	66.00	-16.84	AVG	P
7	0.6020	9.98	43.37	53.35	73.00	-19.65	QP	P
8	0.6020	9.98	39.01	48.99	60.00	-11.01	AVG	P
9	11.4300	10.30	37.88	48.18	73.00	-24.82	QP	P
10	11.4300	10.30	34.29	44.59	60.00	-15.41	AVG	P
11	14.8540	10.38	39.36	49.74	73.00	-23.26	QP	P
12	14.8540	10.38	37.67	48.05	60.00	-11.95	AVG	P

Note: Level = Reading + Factor
 Margin = Level – Limit
 Factor= (LISN, ISN, PLC or Current Probe) Factor + Cable Loss + Attenuator



Power	: AC 240V	Pol/Phase	: NEUTRAL
Test Mode	: Mode 1	Temperature	: 24°C
Test Date	: Oct. 14, 2016	Humidity	: 51%

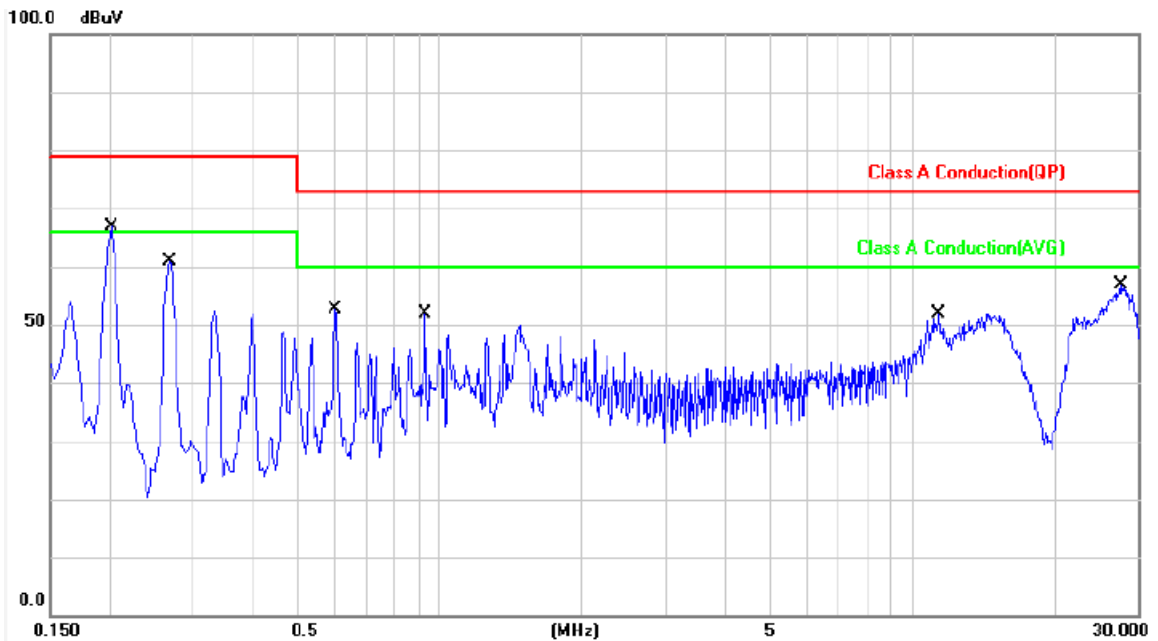

No.	Frequency (MHz)	Factor (dB)	Reading (dBuV)	Level (dBuV)	Limit (dBuV)	Margin (dB)	Detector	P/F
1	0.2010	9.98	55.90	65.88	79.00	-13.12	QP	P
2	0.2010	9.98	51.18	61.16	66.00	-4.84	AVG	P
3	0.2700	9.96	48.87	58.83	79.00	-20.17	QP	P
4	0.2700	9.96	41.59	51.55	66.00	-14.45	AVG	P
5	0.6020	9.95	41.80	51.75	73.00	-21.25	QP	P
6	0.6020	9.95	37.53	47.48	60.00	-12.52	AVG	P
7	0.9340	9.99	40.34	50.33	73.00	-22.67	QP	P
8	0.9340	9.99	37.74	47.73	60.00	-12.27	AVG	P
9	11.4300	10.36	37.81	48.17	73.00	-24.83	QP	P
10	11.4300	10.36	34.46	44.82	60.00	-15.18	AVG	P
11	27.5620	10.69	39.15	49.84	73.00	-23.16	QP	P
12	27.5620	10.69	34.02	44.71	60.00	-15.29	AVG	P

Note: Level = Reading + Factor
Margin = Level – Limit
Factor= (LISN, ISN, PLC or Current Probe) Factor + Cable Loss + Attenuator

Test engineer: Peter



3.6. Test Photographs

Front View



Rear View

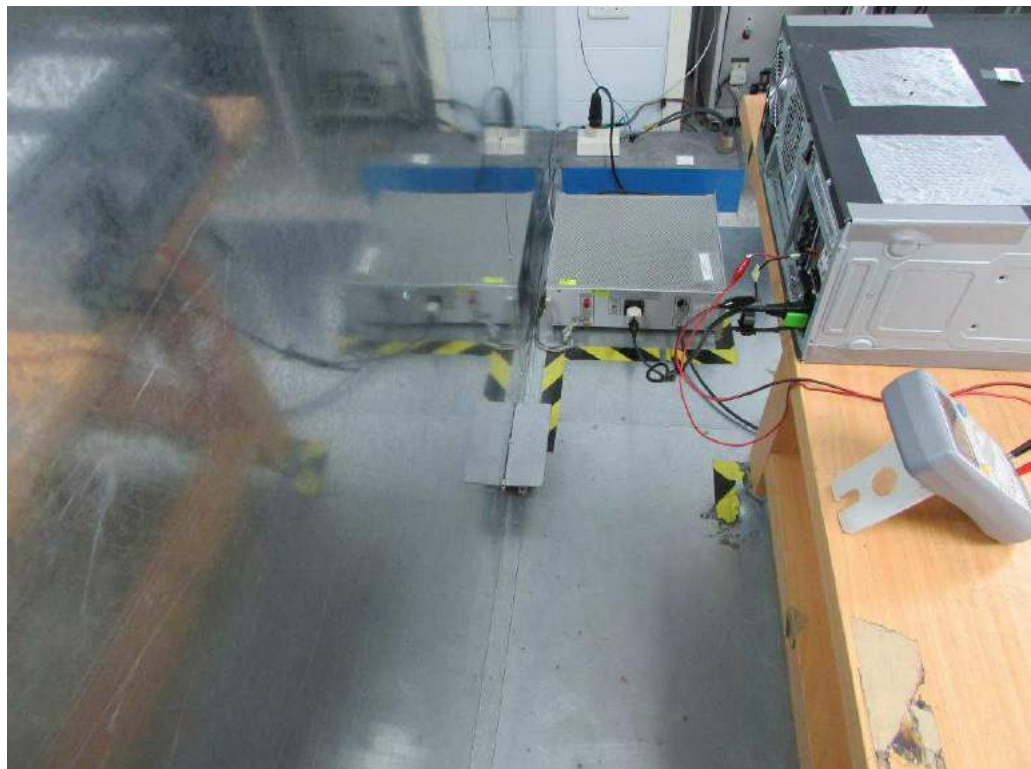



4. Test of Radiated Emission

4.1. Test Limit

The EUT was placed on a nonmetallic stand in the open-field site, 0.8 meter above the ground plane. The interface cables and equipment positions were varied within limits of reasonable applications to determine the positions producing maximum radiated emissions.

Table 1 – Frequency below 1GHz

Frequency (MHz)	Distance Meters	Class A(dB μ V/m)	Class B(dB μ V/m)t
30-230	10	40	30
230-1000	10	47	37

Note: The limit for radiated test was performed according to CISPR 22, which was specified in FCC PART 15B 15.109(g). Also the limits of ICES-003 and CISPR 22 are the same.

Table 2 –Frequency above 1GHz

Frequency (MHz)	Distance Meters	Class A(dB μ V/m)		Class B(dB μ V/m)t	
		Peak	Average	Peak	Average
Above 1GHz	3	80.0	60.0	74.0	54.0

Note: (1) The lower limit shall apply at the transition frequencies.

(2) Emission level (dB μ V/m)= 20 log Emission level(μ V/m)

(3) All emission from a class A/B digital device or system, including any network of conductors and apparatus connected thereto, shall not exceed the level of field strengths specified above.

Table 3 –Frequency range of radiated measurement (for unintentional radiators)

Highest frequency generated or Upper frequency of measurement used in the device or on which the device operates or tunes(MHz)	Range(MHz)
Below 1.705	30
1.705-108	1000
108-500	2000
500-1000	5000
Above 1000	5th harmonic of the highest frequency or 40GHz, which is lower



4.2. Test Procedures

- a. The EUT was placed on a Rota table top 0.8 meter above ground.
- b. The EUT was set 10 meters from the interference receiving antenna which was mounted on the top of a variable height antenna tower.
- c. The table was rotated 360 degrees to determine the position of the highest radiation.
- d. The antenna is a half wave dipole and its height is varied between one meter and four meters above ground to find the maximum value of the field strength both horizontal polarization and vertical polarization of the antenna are set to make the measurement.
- e. For each suspected emission the EUT was arranged to its worst case and then tune the antenna tower (from 1 M to 4 M) and turn table (from 0 degree to 360 degrees) to find the maximum reading.
- f. Set the test-receiver system to Peak Detect Function and specified bandwidth with Maximum Hold Mode.
- g. If the emission level of the EUT in peak mode was 6 dB lower than the limit specified, then testing will be stopped and peak values of EUT will be reported, otherwise, the emissions which do not have 6 dB margin will be repeated one by one using the quasi-peak method and reported.

4.3. Typical test Setup

Below 1GHz Test Setup

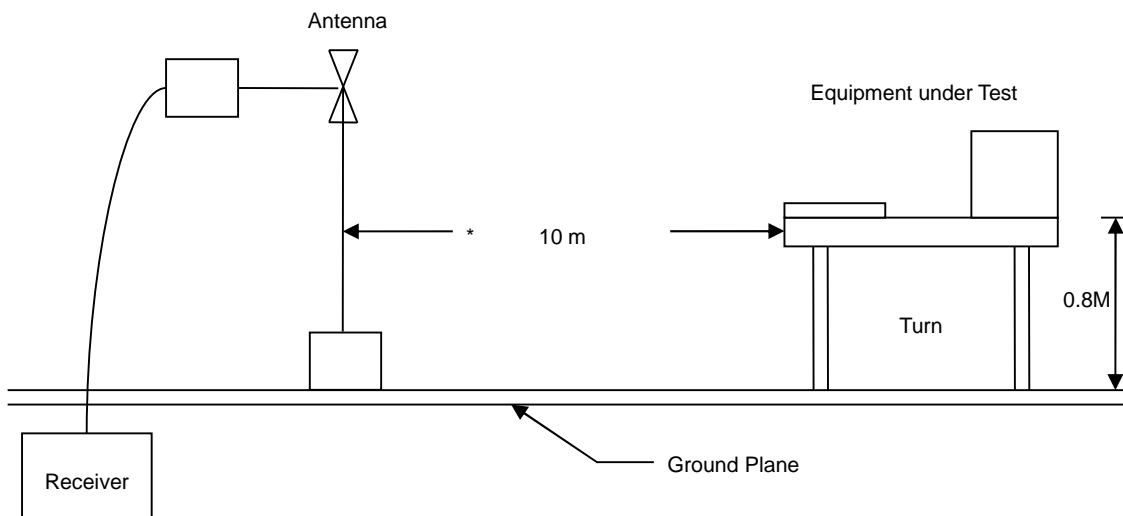



Above 1GHz Test Setup

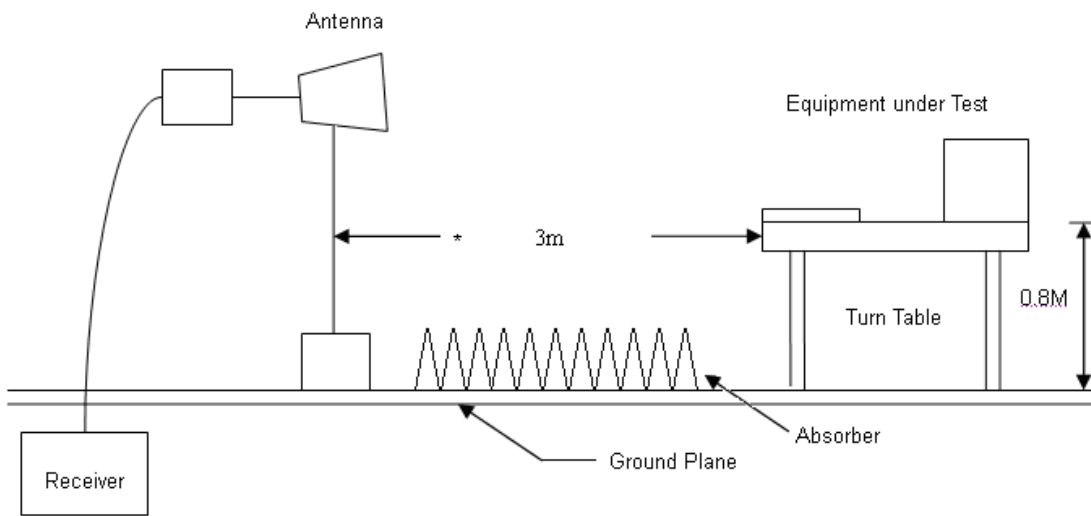

4.4. Measurement Equipment

Instrument	Manufacturer	Model No.	Serial No.	Calibration Date	Valid Date
Bilog Antenna	Sunol	JB1	A020514-2	2016/03/17	2017/03/16
EMI Receiver	R&S	ESCI3	101402	2016/02/18	2017/02/17
Preamplifier	EM Electronics corp.	EM330	60610	2016/02/24	2017/02/23
Software	E3	AUDIX	Version: 8.14.806b	N/A	N/A



4.5. Test Result and Data (30MHz ~ 1GHz)

Power	: AC 120V	Pol/Phase	: VERTICAL
Test Mode	: Mode 1	Temperature	: 25°C
Test Date	: Oct. 17, 2016	Humidity	: 50%

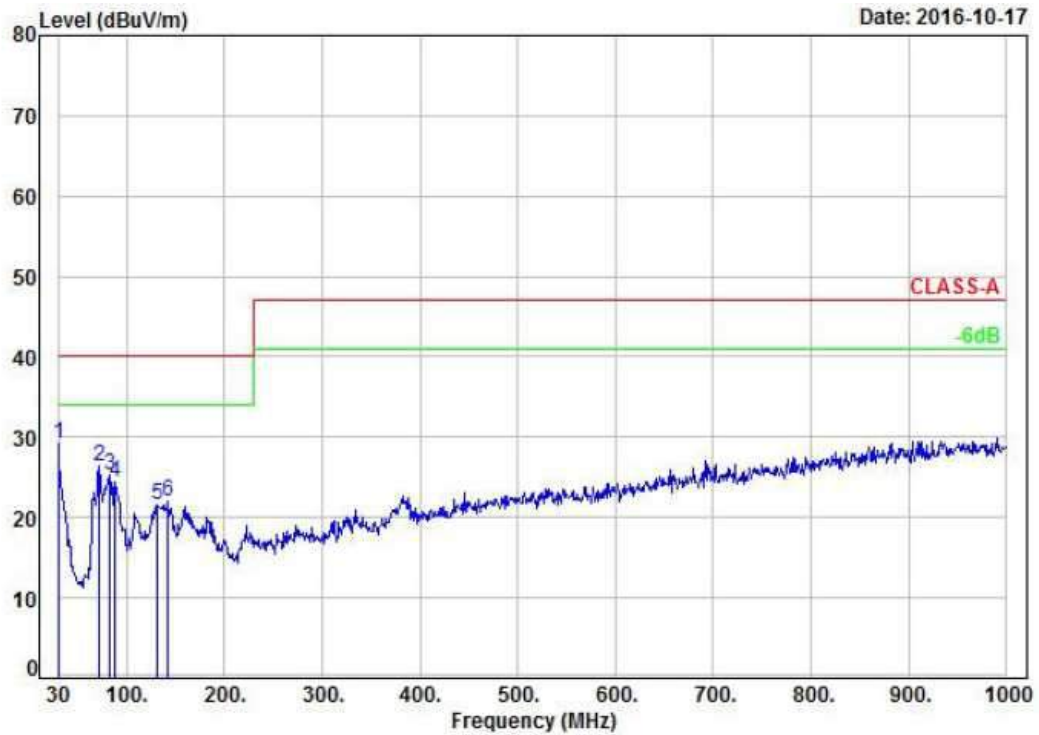

No.	Frequency (MHz)	Factor (dB)	Reading (dBuV)	Level (dBuV)	Limit (dBuV)	Margin (dB)	Detector	Height (cm)	Azimuth (deg)	P/F
1	30.00	-3.17	32.34	29.17	40.00	-10.83	Peak	400	0	P
2	71.71	-15.81	42.14	26.33	40.00	-13.67	Peak	400	0	P
3	82.38	-16.11	41.30	25.19	40.00	-14.81	Peak	400	0	P
4	87.23	-15.95	40.42	24.47	40.00	-15.53	Peak	400	0	P
5	130.88	-9.59	31.22	21.63	40.00	-18.37	Peak	400	0	P
6	142.52	-9.97	31.99	22.02	40.00	-17.98	Peak	400	0	P

Note: Level = Reading + Factor
Margin = Level – Limit
Factor = Antenna Factor + Cable Loss – Amplifier Factor



Power	: AC 120V	Pol/Phase	: HORIZONTAL
Test Mode	: Mode 1	Temperature	: 25°C
Test Date	: Oct. 17, 2016	Humidity	: 50%

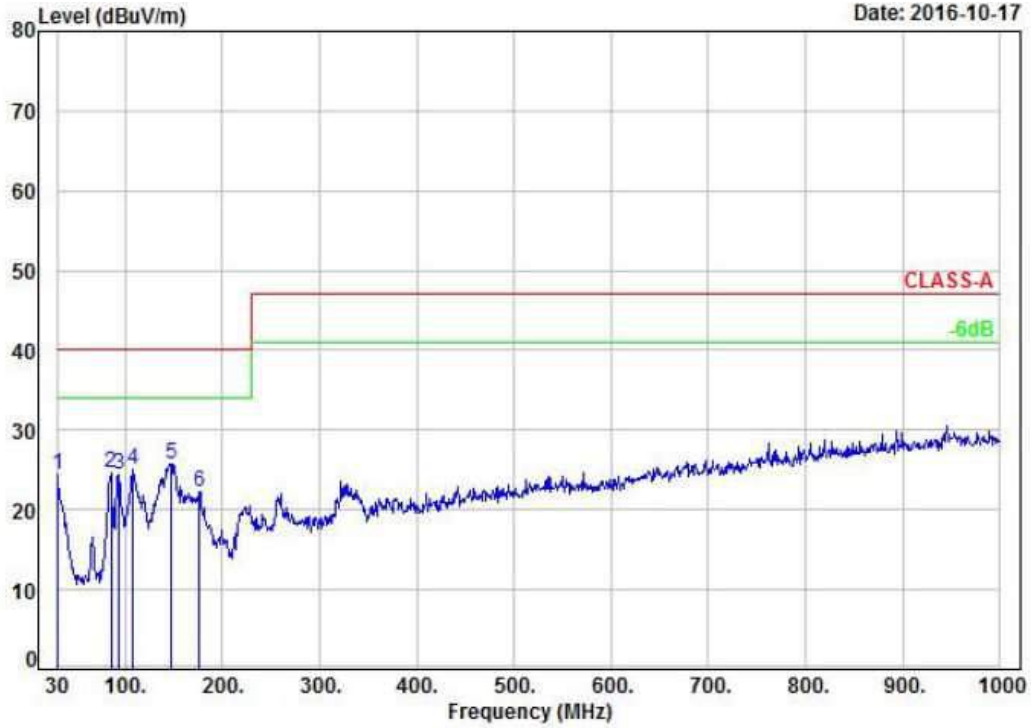

No.	Frequency (MHz)	Factor (dB)	Reading (dBUV)	Level (dBUV)	Limit (dBUV)	Margin (dB)	Detector	Height (cm)	Azimuth (deg)	P/F
1	30.00	-3.17	27.52	24.35	40.00	-15.65	Peak	100	0	P
2	85.29	-16.01	40.71	24.70	40.00	-15.30	Peak	100	0	P
3	93.05	-15.01	39.45	24.44	40.00	-15.56	Peak	100	0	P
4	107.60	-11.20	36.27	25.07	40.00	-14.93	Peak	100	0	P
5	147.37	-10.29	36.05	25.76	40.00	-14.24	Peak	100	0	P
6	176.47	-11.36	33.61	22.25	40.00	-17.75	Peak	100	0	P

Note: Level = Reading + Factor

Margin = Level – Limit

Factor = Antenna Factor + Cable Loss – Amplifier Factor

Test engineer: Charlie



4.6. Test Photographs (30MHz ~ 1GHz)

Front View



Rear View

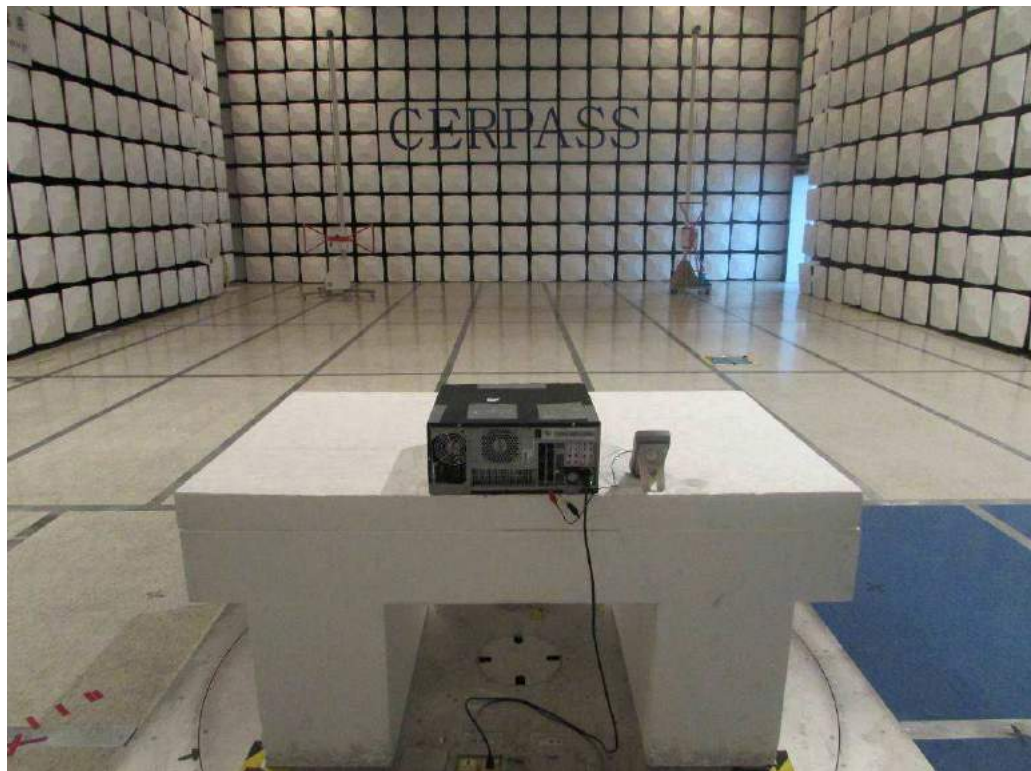

UK Declaration of Conformity

For the following equipment :

Product : Switching Power Supply
Type Designation : FSF050
Trademark : 
Manufacturer's Name : ACBEL POLYTECH INC.
Manufacturer's Address : No.159, Sec. 3, Danjin Rd., Tamsui Dist., New Taipei City, Taiwan

Is herewith confirmed to comply with the following legal requirements. Products sold in the Great Britain (GB) have been assessed to meet high safety, health, and environmental protection requirements.

- Electrical Equipment (Safety) Regulations 2016 : BS EN 62368-1:2014 + A11: 2017
- Electromagnetic Compatibility Regulations 2016 : BS EN 55032:2012+AC:2013 ;
BS EN 55024:2010 ;
BS EN 61000-3-2:2014 ; BS EN 61000-3-3:2013
- The Ecodesign for Energy-Related Products and Energy Information (Amendment) (EU Exit) Regulations 2019 : BS EN 50563:2011/A1:2013
- The Restriction of the Use of Certain Hazardous Substances in Electrical and Electronic Equipment Regulations 2012 : BS EN 50581:2012

Responsible for making this declaration is the :

- Manufacturer
 Authorized representative established within the UK
 Authorized representative established within the UK (if applicable) :

Company Name : _____

Company Address : _____

Person responsible for making this declaration

Name , Surname : Howard Lin/ Acbel Polytech Inc

Position / Title : Safety Supervisor

Taipei , Taiwan
Place

2021-03-24
Date

Legal Signature