







**康舒科技**

ACBEL POLYTECH INC.

## **Contents**

- 1. Specification**
- 2. Mechanical Outline Drawing**
- 3. I/O Label Drawing**
- 4. Carton Drawing**
- 5. Safety**



**康舒科技**

ACBEL POLYTECH INC.

# Specification



ACBEL POLYTECH INC.

# R1C Series 1200W

---

## Power Module Specification

Model Number: R1CA2122A-P Series

AcBel PN: FSF050-00CG

80Plus Platinum Compliant

Note: Outward Airflow

Revision: A00

Release Date: 2015/09/17

Released by: Johnny Ho

Change Date: 2020/05/04

Changed by: Rwei Zong

## REVISION LOG

DATE	SECTION	REVISION	ISSUE / DESCRIPTION
2020/05/04		A00	Reference from FSF050-000G Rev A04
2020/05/04	2.1.7		The efficiency should be allowed 1% tolerance for MP stage.
	2.2.1		AC line voltage shall be reduced from 90VAC/60Hz to 0VAC at constant rate 1 V/secs.
	2.2.2		AC line voltage shall be increased from 0VAC to 90VAC/60Hz at constant rate 1 V/secs.
	2.3.4		For dynamic condition +12V min loading is 2A.
	2.3.6		The fan start when standby mode over 2A load, the +12Vsb output ripple noise should be reference to +240 mVp-p.
	3		Delay from PSON# de-asserted to power supply turning off(Minimum Load):TBD ms Delay from PSON# de-asserted to power supply turning off(Maximum Load):15 ms
	4.1		Logic level high (power supply OFF)from 2.7V to 2.0V.
	4.2		Power down delay: $T_{pwok\_off}$ form Max 200ms to N/A.
	4.3		Logic level high voltage, Isink=50 $\mu$ A form Min 2.4V to 0V.
	5.3		Over Voltage Limits Max(V)form 14.5V to 15V.

## 1. GENERAL SCOPE

This specification describes the performance characteristic of a **1200W** hot swappable AC-DC switching power supply module with a +12V main DC output and a +12Vsb auxiliary output. The power supply shall be able to operate as a single supply or in an N+1 parallel hot-plug able operation with active load sharing in an N+1 redundant configuration.

## 2. ELECTRICAL PERFORMANCE

This Chapter describes the electrical requirements and performance compliances of **R1CA2122A-P** power supply.

### 2.1 POWER INPUT SPECIFICATION

#### 2.1.1 AC Input Voltage

The power supply must operate within all specified limits over the following input voltage range. Harmonic distortion of up to 10% THD must not cause the power supply to go out of specified limits.

PARAMETER	MIN	RATED	MAX	Brown Out	Brown In
Voltage (115)	90V <sub>rms</sub>	100-127V <sub>rms</sub>	140V <sub>rms</sub>	75Vac+/-4V	85Vac+/-4V
Voltage (230)	180V <sub>rms</sub>	200-240V <sub>rms</sub>	264V <sub>rms</sub>		
Frequency	47Hz		63Hz		

#### 2.1.1.1 HVDC Input Voltage

The power supply supports High Voltage Direct Current (HVDC) input over the C14 Inlet. Allowed HVDC input range as shown in below table. The power supply shall operate within all specified limits, when HVDC input meet requirements defined in this chapter.

PARAMETER	MIN	RATED	MAX	Brown Out	Brown In
HVDC (240)	180V <sub>DC</sub>	200-240V <sub>DC</sub>	300V <sub>DC</sub>	165V <sub>DC</sub>	$170V_{DC} \leq V_{DC} < 180 V_{DC}$

#### 2.1.2 Inrush Current

The power supply must meet inrush requirements for any rated AC voltage; during turn on at any phase of AC voltage, during a single cycle AC dropout condition, during repetitive ON/OFF cycling of AC, and over the specified temperature range (T<sub>op</sub>). The peak inrush current shall be less than the ratings of its critical components (including input fuse, bulk rectifiers, and surge limiting device), but shall not exceed 35A in general.

**2.1.3 Input Current**

The maximum input current defines the maximum possible input current to ensure the proper function of the power supply to meet all defined specifications.

Input	Max Current
100Vac – 127Vac	10A
200Vac – 240Vac	8A
240Vdc	6A

**2.1.4 Input Power Factor Correction**

The input Power Factor shall be greater than values defined in below table at power supply’s rated output, and meet Energy Star® requirements.

Output power	10% load	20% load	50% load	100% load
Power factor	>0.90	>0.95	>0.95	>0.98

Tested at 230VAC/50Hz and 115VAC/60Hz.

**2.1.5 Harmonic**

The harmonic input current defined in below table with various loading conditions which tested at 25 deg. C ambient condition. The input voltages are 115VAC/60Hz and 230VAC/50Hz.

Load Condition	10%	20%	50%	100%
115VAC	10%	10%	5%	5%
230VAC	15%	10%	10%	5%

**2.1.6 AC line dropout**

An Input line dropout is a transient condition defined as the line input to the power supply drops to 0 VAC at any phase of the AC line or DC line, for any length of time. During an Input dropout the power supply must meet dynamic voltage regulations requirements. An Input line dropout of any duration shall not cause dripping of the control signals and protection circuits. If the Input dropout lasts longer than the holdup time, the power supply should recover when VIN meets  $V_{IN\ recover}$  and meet all turn on requirements. An Input dropout of any length shall not cause any damage to the power supply.

**Holdup time until Power output goes out of regulations**

Loading	Main output	Standby output
80%	12mS	70mS

**2.1.7 Efficiency**

The efficiency should be measured at 230VAC for AC input power modules only according to Climate Saver / 80Plus efficiency measurement specifications (CSCI-09-10). FAN power loss shall be excluded and need to be deducted from power input.

Efficiency Std.	10% load	20% load	50% load	100% load
Platinum	82%	90%	94%	91%

Note : The efficiency should be allowed 1% tolerance for MP stage.

**2.1.8 AC Line Transient Specification**

AC line transient conditions shall be defined as “sag” and “surge” conditions.

“Sag” conditions are also commonly referred to as “brownout”, these conditions will be defined as the AC line voltage dropping below nominal voltage conditions.

“Surge” will be defined to refer to conditions when the AC line voltage rises above nominal voltage.

The power supply shall meet the requirements under the following AC line sag and surge conditions.

***AC Line SAG and SURGE transient performance.***

**AC Line Sag and Surge (10sec interval between each sagging and surging)**

Duration	Sag	Operating AC voltage	Line frequency	Performance criteria
0 to 1/2 AC cycle	95%	Nominal AC Voltage ranges	50/60Hz	No loss of function or performance
>1 AC cycle	>30%	Nominal AC Voltage ranges	50/60Hz	Loss of function acceptable, self-recoverable
Continues	10%	Nominal AC Voltages	50/60Hz	No loss of function or performance
0 to 1/2 AC cycle	30%	Mid-point of nominal AC Voltages	50/60Hz	No loss of function or performance

**2.1.9 Power Recovery**

The power supply shall recover automatically (auto recover) after an Input power failure. Input power failure is defined to be any loss of Input power that exceeds the dropout criteria.

**2.1.10 Input Line Leakage Current**

The maximum leakage current to ground for power supply system shall not exceed 3.5mA when tested at 230VAC Input voltages.

### **2.1.11 Surge Immunity**

The power supply shall be tested with the system for immunity to AC Unidirectional wave; 2kV line to ground and 1kV line to line, per EN 55024: 1998/A1: 2001/A2: 2003, EN 6100-4-5: Edition 1.1: 2001-04.

The pass criteria include: No unsafe operation is allowed under any condition all power supply output voltage levels to stay within proper spec levels; No change in operating state or loss of data during and after the test profile No component damage under any condition.

## **2.2 BROWNOUT**

Power supply shall contain protection circuitry such that the application of an input voltage below the minimum specified in section 2.1.3 shall not cause damage to the power supply unit nor cause failure of the input fuse and overstress to any other component. In the event of shutdown due to extended brownout, the power supply shall automatically restart after the AC input is within specified limits. The voltage level between shutdown and recovery shall have a minimum of 5 VAC of voltage hysteresis, so that the power supply will not oscillate on and off due to voltage change condition. The power supply shall meet dynamic voltage regulations (Section 2.3.3) and all turn on requirements or turn off requirements while shutdown or recovery.

### **2.2.1 AC Turn off Requirements**

Power supply shall go to power off state after a slow brownout condition. The brownout condition shall be tested with all valid redundant power system configurations using the system. While the power system is operating at full rated DC load, the AC line voltage shall be reduced from 90VAC/60Hz to 0VAC at constant rate 1 V/sec. Power supply shall shutdown at the AC voltage 75VAC±4VAC.

### **2.2.2 AC Turn on Requirements**

Power supply shall return to normal power up state after a slow recovery condition. The recovery shall be test ed in all valid redundant power system configurations. With the test loads configured for maximum system DC output in resistive mode, the AC line voltage shall be increased from 0VAC to 90VAC/60Hz at constant rate 1 V/sec. Power suppl y shall turn up at th e AC voltage 85VAC±4VAC.

### 2.3 POWER OUTPUT SPECIFICATION

#### 2.3.1 Output Power/Currents

The following table defines the power and current rating of the **1200W** power supply.

Voltage	VAC	Min	Max	Peak <sup>*see note</sup>
+12V main high line	200-240	0.5A	100A	150A
+12V main low line	100-127	0.5A	66.7A	86.7A
+12Vsb		0.1A	3A	3.9A

1. Maximum continuous total DC output power should not exceed 1200W.
2. Maximum peak total DC output power should not exceed 1680W.

#### 2.3.2 Peak Power Condition

The power supply shall meet the following peak power conditions.

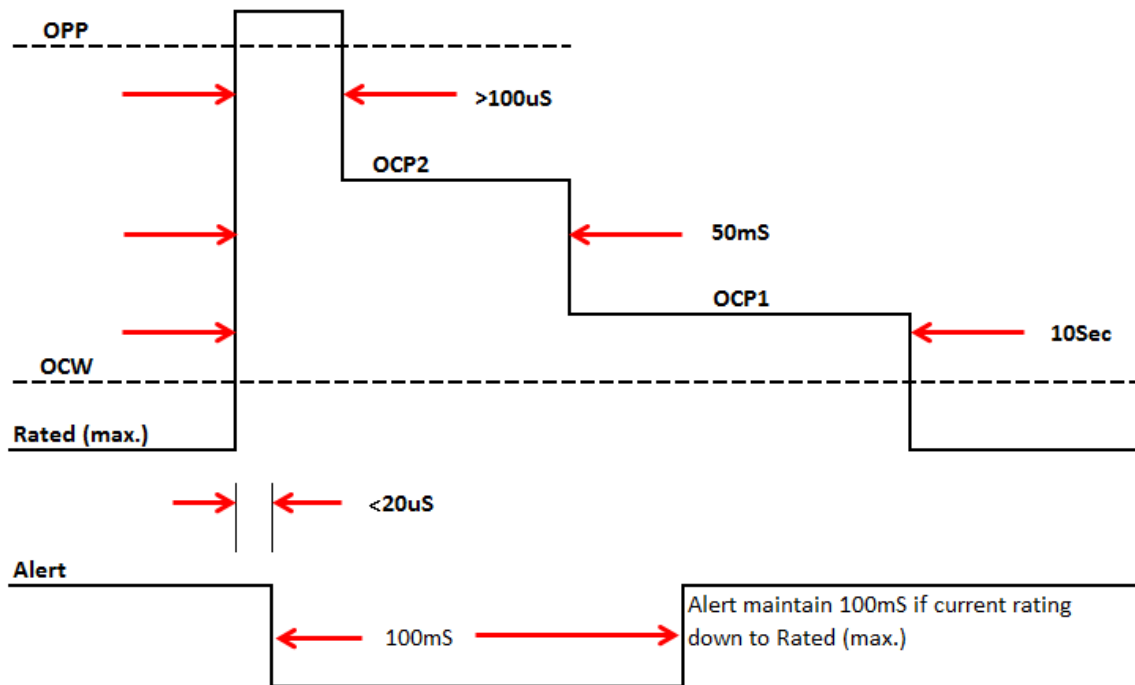

Parameter	MIN	NOM	MAX	Condition
OPP	140%	145%	150%	Keep 100uS at least
OCP2	125%	133%	140%	Keep 50mS at least
OCP1	115%	120%	125%	Keep 10Sec at least
OCW	105%	110%	115%	Continue
Rated	0%		100%	Continue

1. Peak power condition shall be following the peak power table as specify from the above. After exceeding the max. peak power threshold of T<sub>OFF\_PEAK</sub>, the power supply will shut down in a OPP state, and according warning and failures will be reported.

2. The warning signal (OCW) will send to system during 105% - 115% of maximum load, and shuts down after follow by the specified condition.
3. The OPP shall be kept 100uS at least which included < 20uS of SMBAlert and 80uS at least from 12V main rail.

**2.3.3 Voltage Regulation**

The power supply shall stay within the following voltage limits when operating at steady state and dynamic loading conditions. These limits include the peak-peak ripple/noise conditions specified in paragraph 2.3.6. All outputs are measured with reference to the return remote sense (ReturnS) signal.

Parameter	MIN	NOM	MAX	Units	Tolerance
+12V	+11.40	+12.00	+12.60	V <sub>rms</sub>	+/-5%
+12Vsb	+11.40	+12.00	+12.60	V <sub>rms</sub>	+/-5%

**2.3.4 Dynamic Loading**

The power supply shall operate within specified limits and meet regulation requirements for step loading and capacitive loading specified below.

The load transient repetition rate shall be tested between 50Hz to 5kHz at duty cycles ranging from 10%-90%. The load transient repetition rate is only a test specification. The Δ step load may occur anywhere within the MIN load and the MAX load.

Output	ΔStep Load Size	Load Slew Rate	Capacitive Load
+12V	60% of max load	0.5 A/μs	1,000 μF
+12Vsb	1.0A	0.5 A/μs	1,000 μF

Note: For dynamic condition +12V min loading is 2A.

**2.3.5 Capacitive Loading**

The power supply shall meet all requirements with the following capacitive loading ranges.

Output	MIN	MAX	Units
+12V	500	36,000	μF
+12Vsb	20	3,100	μF

### 2.3.6 Ripple and Noise

Ripple and Noise shall be measured over a Bandwidth of 20MHz at the power supply output connector, with minimum capacitive load as specified within paragraph 2.2.4 in parallel with a 10 $\mu$ F tantalum capacitor (minimum 100m $\Omega$  ESR) and with a 0.1 $\mu$ F ceramic capacitor placed at the point of measurement. Maximum allowed ripple/noise output of the power supply is defined in table below.

+12V	+12Vsb
120 mVp-p	120 mVp-p

Note : The fan start when standby mode over 2A load, the +12Vsb output ripple noise should be reference to +240 mVp-p.

The test set-up shall be as shown below:

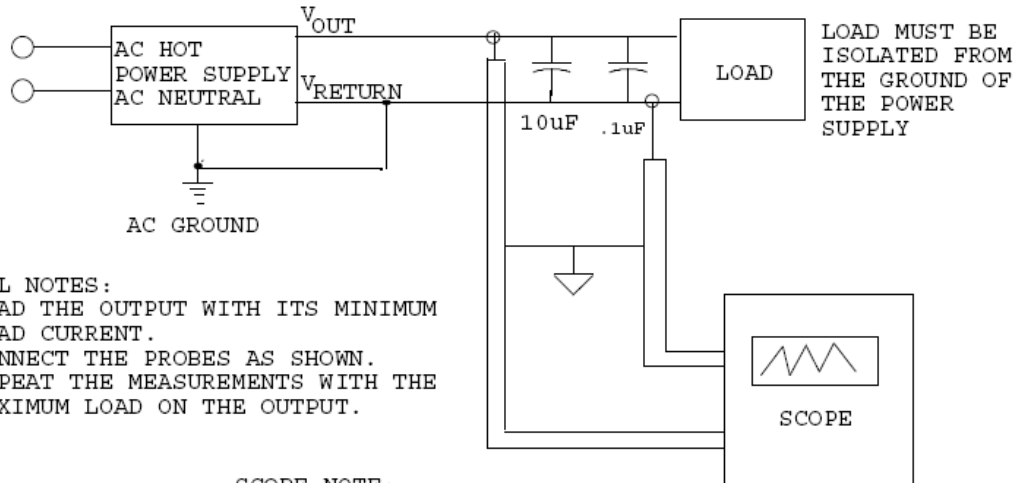

- GENERAL NOTES:
1. LOAD THE OUTPUT WITH ITS MINIMUM LOAD CURRENT.
  2. CONNECT THE PROBES AS SHOWN.
  3. REPEAT THE MEASUREMENTS WITH THE MAXIMUM LOAD ON THE OUTPUT.

SCOPE NOTE:  
 USE A TEKTRONIX 7834 OSCILLOSCOPE WITH 7A13 AND DIFFERENTIAL PROBE P6055 OR EQUIVALENT.

### 3. TIMING REQUIREMENTS

These are the timing requirements for the power supply operation. The output voltages must rise from 10% to within regulation limits ( $T_{vout\_rise}$ ) within 5 to 70ms, and 1 to 25ms for 12Vsb. All main outputs must rise monotonically. Table below shows the timing requirements for the power supply begin turned on and off via the AC input, with PSON held low and the PSON signal, with the AC input applied.

Item	Description	MIN	MAX	Units
$T_{vout\_rise}$	Output voltage rise time for 12V main output	5	70	ms
	Output voltage rise time for 12Vsb output	1	25	ms

#### *Turn On/Off Timing*

Item	Description	MIN	MAX	UNITS
$T_{sb\_on\_delay}$	Delay from ac begin applied to 12Vsb begin within regulation.		1500	ms
$T_{ac\_on\_delay}$	Delay from AC begin applied to all output voltage begin within regulation.		3000	ms
$T_{out\_holdup}$	Time all output voltages stay within regulation after loss of AC.(80% Load)	13		ms
$T_{pwok\_holdup}$	Delay from loss of AC to de-assertion of PWOK.(80% Load)	12		ms
$T_{pson\_off\_delay}$	Delay from PSON# de-asserted to power supply turning off(Minimum Load)		TBD	ms
$T_{pson\_off\_delay}$	Delay from PSON# de-asserted to power supply turning off(Maximum Load)		15	ms
$T_{pson\_on\_delay}$	Delay from PSON# active to output voltages within regulation limits.	5	400	ms
$T_{pson\_pwok}$	Delay from PSON# de-active to PWOK de-assert de-asserted.		5	ms
$T_{pwok\_on}$	Delay from output voltages within regulation limits to PWOK asserted at turn on.	100	500	ms
$T_{pwok\_off}$	Delay from PWOK de-asserted to 12V output voltage dropping out of regulation limits.	1		ms
$T_{psok\_low}$	Duration of PWOK begin in the de-asserted state during an off/on cycle using AC or the PSON# signal.	100		ms
$T_{sb\_vout}$	Delay from 12Vsb begin in regulation to O/Ps begin in regulation at AC turn on.	50	1000	ms
$T_{12VSB\_holdup}$	Time the 12VSB output voltage stays within regulation after loss of AC.	70		ms

#### *Turn On/Off Timing (single Power supply)*

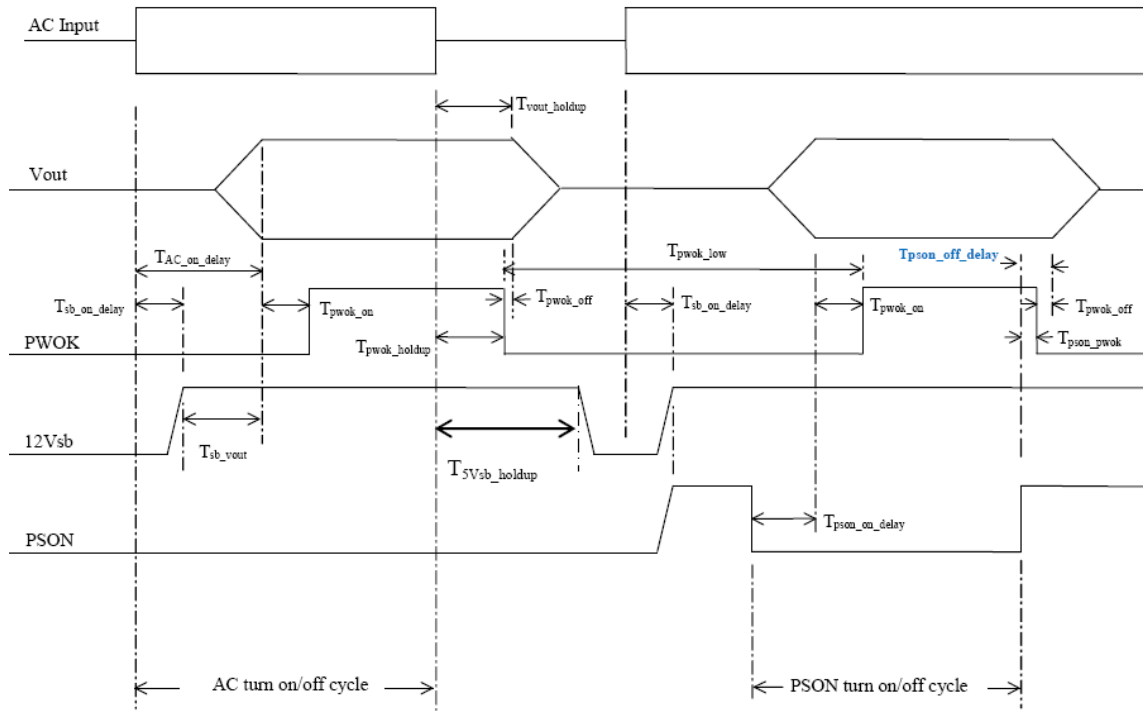

#### 4. CONTROL AND INDICATOR FUNCTIONS

The following section defines the input and output signals from the power supply.

Signals that can be defined as low true use the following convention:

Signal<sup>#</sup> = low true.

##### 4.1 PSON<sup>#</sup> INPUT SIGNAL (POWER SUPPLY ENABLE)

The PSON<sup>#</sup> signal is required to remotely turn on/off the main output of the power supply. PSON<sup>#</sup> is an active low signal that turns on the main output power rail. When this signal is not pulled low by the system or left open, the outputs (except the Standby output) turn off. PSON<sup>#</sup> is pulled to a standby voltage by a pull-up resistor internal to the power supply.

**PSON<sup>#</sup> Signal Characteristic**

Signal Type	Accepts a drain input from the system. Pull-up to 3.3V located in power supply	
PSON <sup>#</sup> = Low	ON	
PSON <sup>#</sup> = High or Open	OFF	
	MIN	MAX
Logic level low (power supply ON)	0V	0.6V
Logic level high (power supply OFF)	2.0V	3.46V
Source current, $V_{pson} = \text{low}$		4mA
Power off delay: $T_{pson\_off\_delay}$		5msec
Power up delay: $T_{pson\_on\_delay}$	5ms	400msec
PWOK delay: $T_{pson\_pwok}$		50msec

##### 4.2 POWER OK (PWOK OR PG) BUS

PWOK is a power good signal and shall be pulled HIGH by the power supply to indicate that all outputs are within regulation limits. When any output voltage falls below regulation limits, an internal failure or when AC power has been removed for a time sufficiently long, so that power supply operation is no longer guaranteed, PWOK will be de-asserted to a LOW state. The start of the PWOK delay time shall inhibited as long as any power supply output is in current limit.

**PWOK / PG Signal Characteristics**

Signal Type	A drain output from power supply. Pull-up to 3.3V located in the power supply	
PWOK = High	Power OK	
PWOK = Low	Power Not OK	
	MIN	MAX
Logic level low voltage, $I_{sink} = 4\mu\text{A}$	0V	0.4V
Logic level high voltage, $I_{source} = 200\mu\text{A}$	2.4V	3.46V
Sink current, PWOK = low		400 $\mu\text{A}$
Source current, PWOK = high		2mA
PWOK delay: $T_{pwok\_on}$	100ms	500ms
PWOK rise and fall time		100 $\mu\text{sec}$
Power down delay: $T_{pwok\_off}$	1ms	

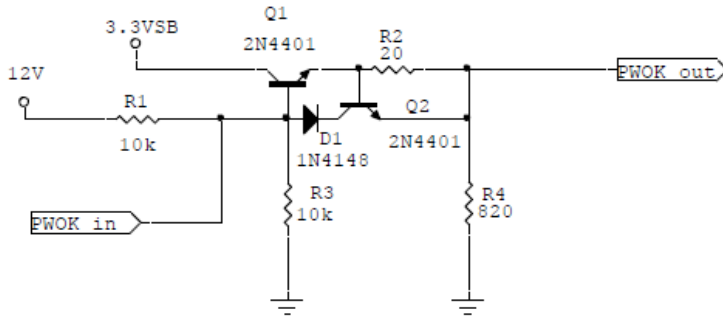

### 4.3 SMBAlert# Signal

This signal indicates that the power supply is experiencing a problem that the user should investigate. This shall be asserted due to Critical events or Warning events and activate in the case of SMBAlert mask setting by user(note). This signal may also indicate the power supply is reaching its end of life or is operating in an environment exceeding the specified limits. This signal is to be asserted in parallel with LED turning solid Amber or blink Amber.

**Note: There are input UVP 、 output OCW 、 OTW assert SMBAlert# follow Intel SPEC.**

**SMBAlert# Signal Characteristics**

Signal Type (Active Low)	A drain output from power supply. Pull-up to 3.3V located in power supply.	
Alert# = High	<b>OK</b>	
Alert# = Low	<b>Power Alert to system</b>	
	<b>MIN</b>	<b>MAX</b>
Logic level low voltage, Isink=4 mA	0 V	0.4 V
Logic level high voltage, Isink=50 μA		3.46 V
Sink current, Alert# = low		4 mA
Sink current, Alert# = high		50 μA

### 4.4 Cold Redundant\_Bus (CR\_BUS) Signal

This signal is used for power supply to power supply communication in front of an interrupt. This interrupt is by default low impedance low. For all power supplies connected to this bus shall have an open collector and a pull high circuitry, which can provide at least 4mA.

This function shall be PMBus controlled and allows the system, to set the power module into four different modes:

1. MASTER – Load dependent function
2. SLAVE – Load dependent function
3. MASTER – HVDC Input dependent function
4. SLAVE – Master dependent function

SLAVE’s in CR Standby shall provide PG and LED should be 1Hz Blink GREEN.

**CR\_BUS# Signal Characteristics**

Signal Type (Active HIGH)	A drain output from power supply. Pull-up to 3.3V in power supply	
<b>CR_BUS# = High</b>	<b>CR Standby Allowed</b>	
<b>CR_BUS# = Low</b>	<b>SLAVEs need to be Active ON</b>	
	<b>MIN</b>	<b>MAX</b>
<b>Logic level low voltage, Isink=4 mA</b>	0 V	0.4 V
<b>Logic level high voltage, Isource=4 mA</b>	2.4 V	3.46 V
<b>Sink current, CR_BUS# = low</b>		4 mA
<b>Sink current, CR_BUS# = high</b>		4 mA
<b>CR_BUS# rise and fall time</b>		100 μs

**5. PROTECTION CIRCUITS**

Protection circuits shall cause only the power supply’s main outputs to shutdown (latch off). If the power supply latches off due to a protection circuit tripping, an AC cycle OFF for 15 second or a PSON# cycle HIGH for 1 second must be able to reset the power supply. The auxiliary output shall not be affected by any protection circuit, unless the auxiliary output itself is affected.

**5.1 CURRENT LIMIT**

The power supply shall prevent the main and auxiliary outputs from exceeding the values shown in below Table. If the main current limits are exceeded the power supply will shut down and latch off. The latch will be cleared by toggling the PSON# signal or by an AC power interruption. The power supply shall not be damage from repeated power cycling in this condition. *The auxiliary output shall be auto recover (Vsb<sub>AR</sub>) after the OCP/SCP had been removed.*

**Over Current Protection**

<b>Voltage</b>	<b>Over Current Limit (Iout limit)</b>
+12V	110% minimum, 150% maximum
+12Vsb ( <i>Auxiliary</i> ) <sub>AR</sub>	110% minimum, 150% maximum

**5.2 FAST OUTPUT CURRENT SENSING**

The power supply shall have a circuit to quickly assert the SMBAlert signal when the output current exceeds the I<sub>throttle</sub> threshold. A current sense resistor on the output side of the PSUs output capacitors shall be used to quickly sense current exceeding the I<sub>throttle</sub> threshold. The SMBAlert# signal shall assert within T<sub>fast\_smbalert</sub> time. The PSU shall hold the SMBAlert# signal asserted for T<sub>smbalert\_latch</sub> duration then release it.

Key characteristics of the fast output current sensing requirements

- Ithrottle < minimum OPP level (SMBAlert must assert before current/power hits the OPP threshold)
- Tfast\_smbalert < 20uSec
- Tsmbalert\_latch = 100mSec (+/-50mSec)

### 5.3 OVER VOLTAGE PROTECTION

The power supply shall shutdown and latch off after an over voltage condition occurs. This latch will be cleared by toggling the PSON# signal or by an AC power interruption.

A shutdown caused by an over-voltage in one power supply will not cause the other (redundant) power supply to shuts down.

The over-voltage threshold is defined in table below.

<b>Over Voltage Limits</b>		
<b>Output Voltage</b>	<b>MIN (V)</b>	<b>MAX (V)</b>
+12V	13.8	15
+12Vsb ( <i>Auxiliary</i> )AR	13.3	15

### 5.4 OVER TEMPERATURE PROTECTION

The power supply shall be protected against over temperature conditions caused by loss of fan cooling or excessive ambient temperature which could cause internal part failures. In an over temperature condition the power supply shall shutdown, then recover after while the temperature back in normal condition. The 12VSB shall not shutdown during an OTP condition on the main outputs.

The temperature warning setting point is showing on below table:

<b>Condition</b>	<b>Warning in °C</b>	<b>Critical in °C</b>	<b>Timing for LED</b>	<b>Timing for SMBAlert<sup>#</sup></b>
T <sub>READ</sub>	60	65	1sec	100usec

T<sub>READ</sub>: Environment Temperature

## 6. LED IDENTIFICATION

There is one indicator LED located on the front faceplate.  
Status showing on below:

Power Supply Condition	LED State
Output ON and OK	GREEN
Only 12Vsb on (PS off) or PSU in Cold redundant state	1Hz Blink GREEN
Power supply warning events where the power supply continues to operate high temp, high power, high current, slow FAN.	1Hz Blink AMBER
Power supply critical event causing a shutdown; AC cord unplugged or AC power lost, failure, OCP, OVP, FAN fail.	AMBER

## 7. POWER SUPPLY MANAGEMENT

### 7.1 HARD WARE LAYER

The serial bus communication devices for Power Supply Management Controller (PSMC) and Field Replacement Unit (FRU) in the power supply shall be compatible with both SMBus 2.0 “high power” and I<sup>2</sup>C Vdd based power and drive specification.

This bus shall operate at 3.3V. The power supply should have internal pull-ups on the SMBus. Two pins are allocated on the power supply. One pin is the serial clock (SCL). The second pin is used for serial data (SDA). Both pins are bi-directional and are used to form a serial bus. The device(s) in the power supply shall be located at an address(s) determined by addressing pins A0 and A1 on the power supply module. The circuits inside the power supply shall derive their 3.3V power from the 12VSB bus through a buffer. Pull-up resistors shall be on SCL or SDA inside the power supply. Pull-up resistor is 10K ohm for SDA and SCL separately.

#### 7.1.1 Capacitance for SMBus

The recommended Capacitance per pin on SDA and SCL shall be 10pF, and is not allowed to exceed 40pF per pin. In an N+1 configuration of up to four (4) power modules with additional PDB, the total Capacitance of each Bus pin shall not exceed 400pF.

#### 7.1.2 I<sup>2</sup>C Bus Noise Requirement

The power supplies I<sup>2</sup>C Bus’ SDA and SCL line shall be clean from noise, which might affect the proper function when utilized with other devices.

The maximum allowed line noise on SDA or SCL is 200mV.

### 7.2 POWER SUPPLY MANAGEMENT CONTROLLER (PSMC)

The PSMC device on the PDB shall derive its power of the 12Vsb output on the system side of the O’ring device and shall be grounded to return. It shall be compatible with SMBus specification 2.0 and PMBus™ Power System Management Protocol Specification Part I and Part II in Revision 1.2 or later

It shall be located at the address set by the A0 and A1 pins.  
 Refer to the specification posted on [www.ssiforum.org](http://www.ssiforum.org) and [www.pmbus.org](http://www.pmbus.org) website for details on the power supply monitoring interface requirements and refer to followed section of supported features. The below table reflect the power module addresses complying with the position in the housing.

PDB position and PSMC address	PM1 B0h/B1h	PM2 B2h/B3h	PM3 B4h/B5h	PM4 B6h/B7h
Pin A0/A1	0/0	1/0	0/1	1/1

Note: Pull-up resistor is 14.3K ohm for A0 and A1 separately.

**7.3 Sensor Accuracy**

The sensor of the PSMC shall meet below accuracy requirements for sensor readings. The accuracy shall be met at the specified environmental condition and the full range of rated input voltage.

**Sensor Accuracy Table**

Sensor	0%-10% load	>10%-20% load	>20%-100% load
Current	± 5% or 0.5A	± 5% or 0.5A	± 3%
Voltage	± 5%	± 3%	± 3%
Output Power	± 10W	± 5% or 10W	± 3%
Temperature	± 3°C with Δ5%		
FAN	± 10% from Spec.		
Input Power	± 10W	± 5%	± 3%

**\*\* PMBus compliance please refer to firmware specification \*\***

**8. ENVIRONMENTAL**

**8.1 TEMPERATURE REQUIREMENTS**

The power supply shall operate within all specified limits over the Top temperature range. The average air temperature difference ( $\Delta T_{ps}$ ) from the inlet to the outlet of the power supply shall not exceed the values shown below Table. All airflow shall pass through the power supply and not over the exterior surfaces of the power supply

ITEM	DESCRIPTION	MIN	MAX	UNITS
Top	Operating temperature range.	0	50	°C
Tnon-op	Non-operating temperature range.	-40	70	°C

**8.2 HUMIDITY**

Operating: 10% to 95% relative humidity, non-condensing.  
 Storage: 10% to 95% relative humidity, non-condensing.

**8.3 ALTITUDE**

Operating: to 5,000m  
 Non-operating: to 15,200m

**8.4 VIBRATION**

Operating: 0.01G<sup>2</sup>/Hz at 10Hz, 0.02G<sup>2</sup>/Hz at 20Hz.  
 Non-Operating: 0.02G<sup>2</sup>/Hz form 20Hz to 1000Hz.

**8.5 MECHANICAL SHOCK**

Operating: 5G, no malfunction.  
 Non-operating: 50G, no damage. Trapezoidal Wave, Velocity change = 4.3m/sec. Three drops in each of six directions are applied to each of the samples.

**8.6 EMI/EMC REQUIREMENTS**

The power supply shall comply with FCC part 15, CRISP 22 and EN55-22; Class A for both conducted and radiated emissions with a 3dB margin. Test shall be conducted using a shielded DC output cable to a shielded load. The load shall be adjusted to 100% load. Tests will be performed 800W output power at 120VAC/60Hz and 1200W output power at 230VAC/50Hz.

## **9. REGULATORY REQUIREMENTS**

### **9.1 PRODUCT SAFETY COMPLIANCE**

The power supply will have the following safety approvals with most current editions:

- A) UL 60950-1/CSA 60950-1 Edition 2 (USA/Canada)
- B) TUV EN60950-1 Edition 2 (Europe)
- C) IEC60950-1 Edition 2 (International)
- D) CB Certificate & Report, IEC60950-1 Edition 2
- E) CE – Low Voltage Directive 2006/95/EC (Europe)
- F) BSMI (Taiwan)
- G) GB4943-2011 Certification (China)
- H) KCC (Korea)

### **9.2 ELECTROSTATIC DISCHARGE**

The objective of ESD test is to determine the susceptibility and immunity of products to electrostatic discharge to which the products may be exposed, when operating under all potential environmental conditions. The test conditions and setup shall conform to that outlined in CISPR24-2 and IEC 801-2 (EN55101-2).

Air discharge: 8KV not allow error.

Contact discharge: 4KV not allow error.

Note: The above test discharge time is 1 time/sec and repeats each test 10 times.

### **9.3 HI-POT**

The power supply module in the system shall be test at 1800Vac, with a trigger limit of 30mA.

## **10. RELIABILITY**

The MTBF of the power supply can be calculated with the Part-Stress Analysis method of Bell Core SR332 of the quality factors. A calculated MTBF of the power supply shall be at least 100,000 hours at 50 °C ambient with 230VAC and in full load condition.

### **10.1 Electrolyte Capacitor Life**

The used electrolyte capacitor shall have a minimum life of 5 years.

- Perform the test for 230Vac/50Hz input voltage.
- Perform the test for 80% maximum load and Only Standby Load(3A).
- Perform the test at 35°C ambient temperature.

### 11. RoHS COMPLIANCE

The directive 2002/95/EC of the European Parliament and of the Council of the 27th January 2003, on the restriction of the use of certain hazardous substances in electrical and electronic equipment, requires the reduction of the substances Lead, Mercury, Cadmium, Hexavalent Chromium, Polybrominated Biphenyls (PBB), and Polybrominated Biphenyl ethers (PBDE) in electronic products by July 1, 2006. Unless otherwise noted, all materials used will be compliant with this directive and any subsequent revisions or amendments.

### 12. MECHANICAL DIMENSIONS

Dimension (L x W x H): 185 x 73.5 x 40mm / 7.28 x 2.89 x 1.57inch

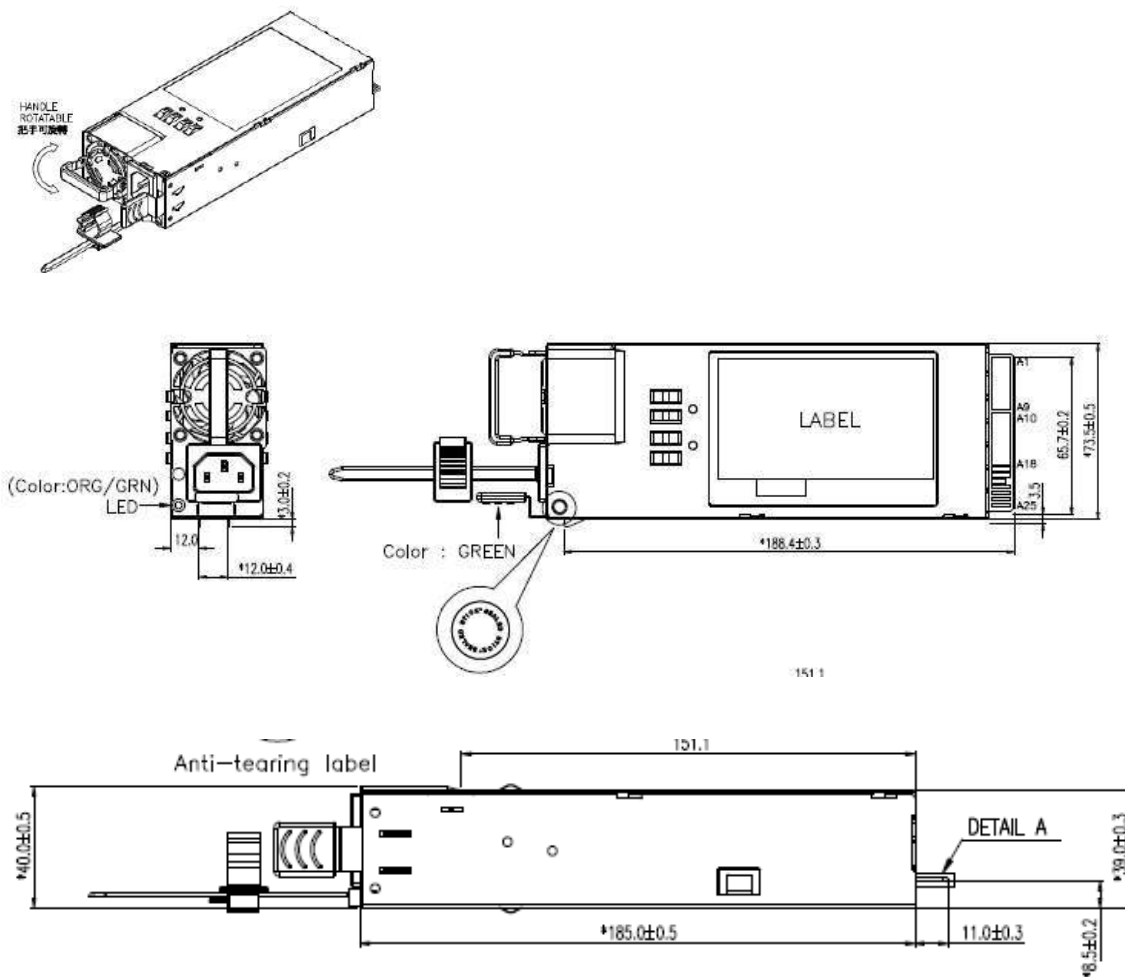

**NOTE:** Above drawing is for reference only, detail dimension should refer to independent mechanical drawing.

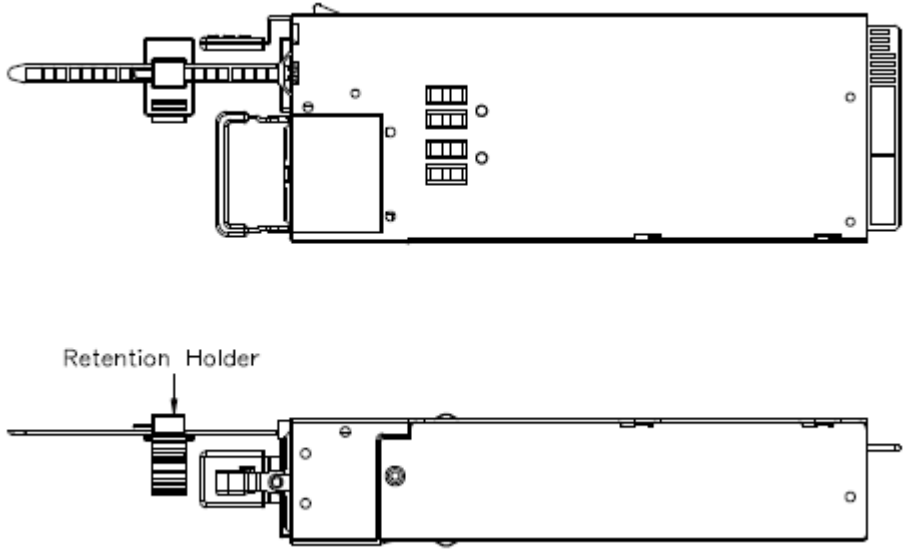

The height of adapter gold finger to the bottom is 8.5mm

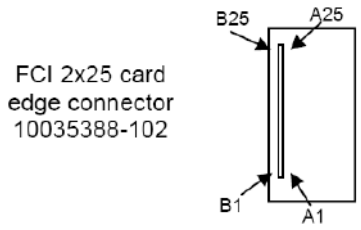
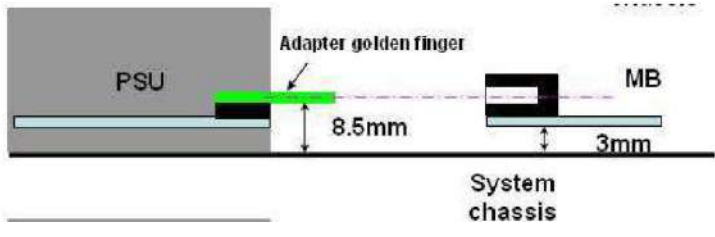

FCI 2x25 card edge connector 10035388-102

**12.1 DC Output connector**

The power supply shall use a card edge output connection for power and signal that is compatible with a 2x25 Power Card Edge connector (equivalent to 2x25 pin configuration of the FCI power card connector 10035388-102LF or ALLTOP C21009-102H3-Y).

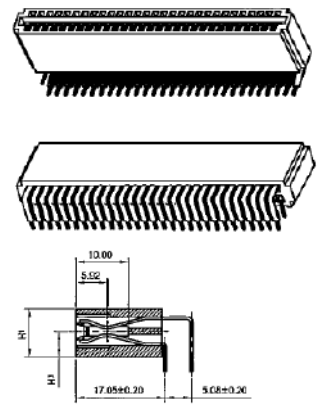

## Gold finger pin assignment

## OUTPUT PIN ASSIGNMENT

PIN	SIGNAL_NAME	PIN	SIGNAL_NAME
A1	GND	B1	GND
A2	GND	B2	GND
A3	GND	B3	GND
A4	GND	B4	GND
A5	GND	B5	GND
A6	GND	B6	GND
A7	GND	B7	GND
A8	GND	B8	GND
A9	GND	B9	GND
A10	+12V	B10	+12V
A11	+12V	B11	+12V
A12	+12V	B12	+12V
A13	+12V	B13	+12V
A14	+12V	B14	+12V
A15	+12V	B15	+12V
A16	+12V	B16	+12V
A17	+12V	B17	+12V
A18	+12V	B18	+12V
A19	PMBus SDA	B19	A0 (SMBus address)
A20	PMBus SCL	B20	A1 (SMBus address)
A21	PSON	B21	12VSB
A22	SMBAAlert#	B22	CR_BUS#
A23	Return Sense	B23	12V load share Bus
A24	+12V Remote Sense	B24	NC(Reserved)*
A25	PWOK	B25	NC

## Description Gold finger

## OUTPUT PIN DEFINITION

Pin No.	Pin Name	Pull Up Resistor	Description
A1~A9 B1~B9	GND	N/A	12V main & 12VSB Return
A10~A18 B10~B18	12V	N/A	12V main output
A19	SDA	10K ohm is pulled high to 3.3V(damping 47ohm)	SMBus/PMBus Data
A20	SCL	10K ohm is pulled high to 3.3V(damping 47ohm)	SMBus/PMBus Clock
A21	PSON	14.3K ohm is pulled high to 3.3V	Active low; 12V main output on/off control
A22	SMBAlert	5.1K ohm is pulled high to 3.3V, 0 ohm is pull low to GND.	Active High; Alert Signal (interrupt)
A23	RETURN_S	N/A	12V main output Remote Sense (-)
A24	+12VRS	N/A	12V main output Remote Sense (+)
A25	PWOK	20 ohm is pulled high to 3.3V, 820 ohm is pulled low to GND	Active high; Indicate 12V main is valid.
B19	A0	14.3K ohm is pulled high to 3.3V	PMBus Address 0
B20	A1	14.3K ohm is pulled high to 3.3V	PMBus Address 1
B21	12VSB	N/A	Standby Voltage
B22	CR_Bus#	Connect to other PSU b22	Cold Redundant BUS
B23	12VLS	Connect to other PSU b23.	12V main output load current sharing
B24	N/A	N/A	Power Supply NC(Reserved)*
B25	NC	N/A	Not connect



**康舒科技**

ACBEL POLYTECH INC.

# **Mechanical Outline Drawing**

NOTE :

1. UNIT : MM. 單位 : 毫米
2. MATERIAL : SGCC. 材質 : SGCC

THICKNES : COVER 0.8 mm , CHASSIS 0.8 mm

厚度 : 上蓋 0.8 mm , 下蓋 0.8 mm

3. NET WEIGHT : 800g±3% 淨重 : 800克 3%

4. " \* " CRITICAL DIMENSION. THE SUPPLIER COMPLY TO ACBEL SPEC DIMENSION FOR EVERY SHIPMENT.

" \* " 表示該(尺寸/位置)為設計之重點尺寸, 供應商每次出貨前必須檢驗合格後, 方可出貨.

5. THESE MATERIAL/PART/ASSEMBLY MUST COMPLY TO

ACBEL SPEC "CRITERIA FOR ENVIRONMENT-RELATED SUBSTANCES" .

材質/零件/製程均必須符合康舒"環境管理物質規範".

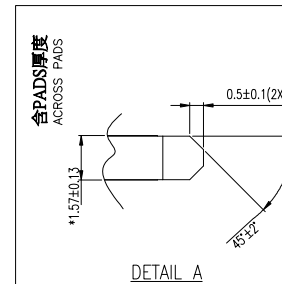
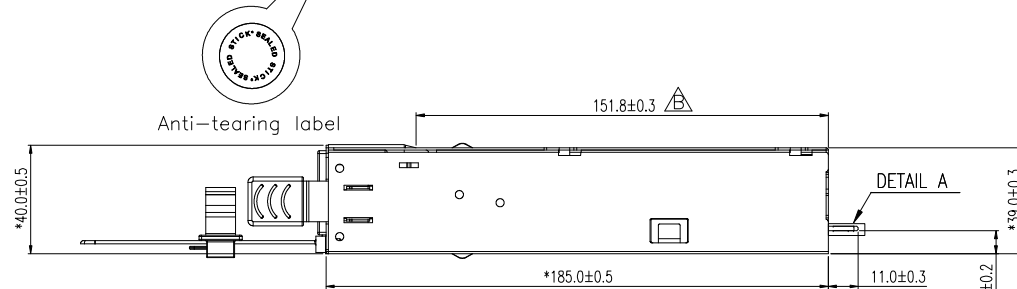
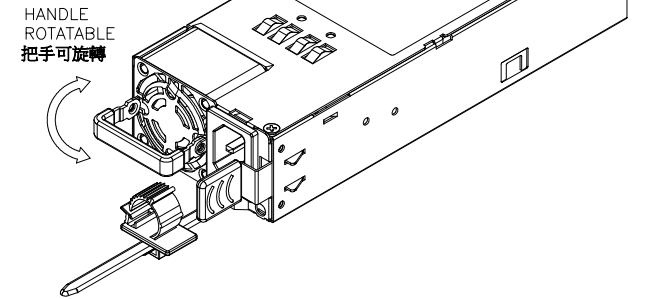
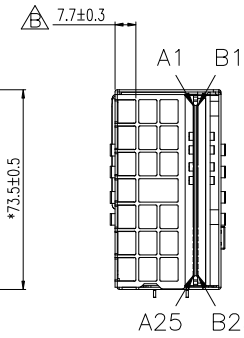
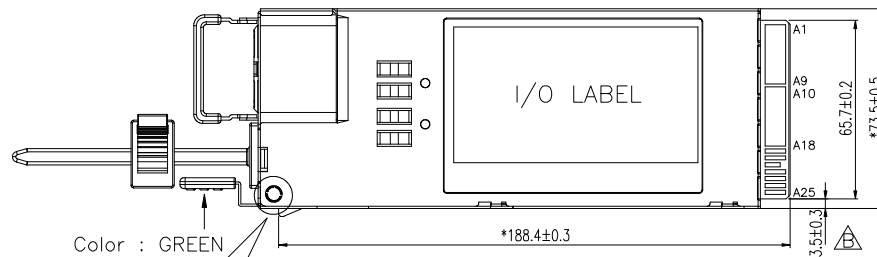
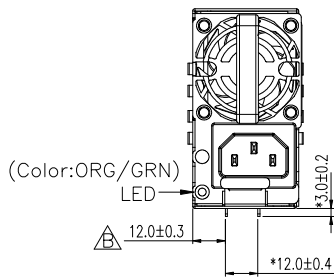
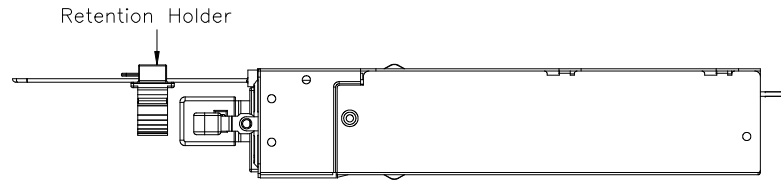
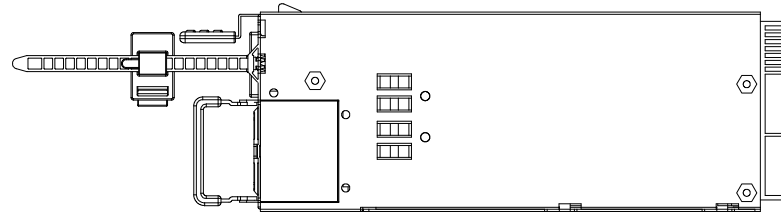

RELEASE	
正式發行圖面	REV: B
ENG. Ting	APPR.

△ 圖面增加公差	TING	10/18/19
A RELEASE	JianTing	04/07/17
1 PRIMARLY	Y.C	06/29/16
REV	DESCRIPTION	BY DATE
 ACBEL POLYTECH INC.		MODEL NO. FSF050-00AG
		PART NO. MO-FSF050-00AG
		DWG NO. MO-FSF050-00AG_B
 Metric A1		TITLE
 THIRD ANGLE PROJECTION		MECHANICAL OUTLINE
SCALE 1:1	SHEET 1 OF 1	DESIGNER TING 10/18/19
		CHECKED
		APPROVED



**康舒科技**

ACBEL POLYTECH INC.

# I/O Label Drawing

NOTES:

1. UNIT: MM; 單位: 毫米
2. MATERIAL 材質:
  - 2.1 FACE STOCK: WHITE POLYESTER 50#, THICKNESS = 0.05 MM  
底材: 白霧龍 50#, 厚度 = 0.05MM
  - 2.2 OVERLAMINATION 保護膜:
    - A TRANSPARENT FILM 透明膠膜
    - NONE 無
  - 2.3 ADHESIVE 背膠:
    - PRESSURE SENSITIVE MESH ACRYLIC, THICKNESS = 0.035 MM
    - 壓花膠, 厚度: 0.035 毫米
  - 2.4 BACKED WITH RELEASE LINER 背面附離型紙
  - 2.5 LABEL TO BE AFFIXED TO:
    - 貼紙所貼附之材質:
      - GALVANIZED STEEL 鍍鋅鋼
      - ALUMINUM 鋁
      - NICKEL PLATED METAL 鍍鎳金屬
      - ZINC PLATED METAL WITH CHROMATE POST 後處理之鍍鉻酸鋅金屬
  - 2.6 MAXIMUM TEMPERATURE RATING:
    - 100°C 攝氏100度
  - 2.7 MATERIAL MUST BE UL RECOGNIZED AND COMPLY TO UL 969 STANDARD.  
材質必須符合 UL 認證, 並且遵從 UL 969 標準.
3. LABEL MUST BE MADE BY A UL RECOGNIZED AND CSA APPROVED VENDOR.  
貼紙之製造商必須是 UL 與 CSA 所認證.
4. ALL PRODUCTS MUST BE THE SAME AS ENGINEERING APPROVED SAMPLES. ANY MODIFICATION MUST BE APPROVED BY API MECHANICAL ENGINEERING SECTION.  
所有產品必須與認可的樣品一致, 任何的修改都必須經過康舒機構工程師同意及認可.
5. LABEL MUST CONTAIN THE VENDOR'S ID MARK LOCATED IN THE AREA INDICATED.  
貼紙必須印製廠商代碼.
6. PRINTED COLOR 列印顏色:  
BLACK - TEXT, GRAPHICS, IMAGE, LOGO SURROUND SHAPE  
黑色 - 文字, 圖形, 圖像, 標誌, 外圍圖形  
WHITE - BACKGROUND  
白色 - 背景
7. ⊕ FAI IS THE CRITICAL DIMENSION. FOR EVERY SHIPMENT, MUST FULLY INSPECT THREE SAMPLE PARTS AND PROVIDE A REPORT, THE REPORT MUST BE VALIDATED.  
FAI尺寸為設計之重點尺寸, 每次出貨前須量測3PCS並提供FAI報告, 須合格方可出貨.
8. ⊕ CPK IS THE DIMENSION PRODUCED BY STATISTICAL PROCESS CONTROL.FOR EVERY SHIPMENT, MUST FULLY INSPECT THIRTY SAMPLE PARTS AND PROVIDE A REPORT, CPK表示該(尺寸/位置)為製程管控尺寸, 供應商每次出貨前須量測30 PCS並提供CPK報告, 須合格方可出貨.
9. THESE MATERIAL/PART/ASSEMBLY MUST COMPLY TO ACBEL SPEC "CRITERIA FOR ENVIRONMENT-RELATED SUBSTANCES".  
材質/零件/製程均必須符合康舒"環境管理物質規範".
10. USES OF RED PHOSPHORUS MATERIAL IS PROHIBITED.  
禁止使用含有紅磷材料.
11. USES OF EU RoHS & RoHS 2.0(HBCDD/DEHP/BBP/DBP) MATERIAL IS PROHIBITED  
禁止使用EU RoHS & RoHS 2.0(HBCDD/DEHP/BBP/DBP)物質
12. PLEASE FOLLOW ACBEL'S REQUIREMENT FOR HF.  
遵守康舒無鹵要求.

<b>RELEASE</b>			
正式發行圖面		REV:I	
ENG.	Eason	APPR.	Arthur

	UPDATE FCC STATEMENTS	2023/11/22	Eason
	UPDATE KC LOGO	2023/08/25	Eason
	UPDATE CCC/BSMI WARNING UPDATE LABEL LOGO TYPESETTING	2023/08/16	Eason
F	UKCA ADDRESS Cresscent TO Crescent	2021/08/18	TING
E	ADD UKCA LOGO	2021/03/12	TING
D	ADD FCC WARNING STATEMENTS	2018/10/04	TING
C	3C LOGO REMOVE S&E	2018/08/15	TING
A	RELEASE	2017/08/15	JianTing
1	PRIMARILY	2016/06/28	Y.C
REV	DESCRIPTION	DATE	BY

REVISION			
 ACBEL POLYTECH INC.	DRAWINGS & SPEC. ARE THE EXCLUSIVE PROPERTY OF ACBEL POLYTECH INC. SAID ITEMS ARE ISSUED IN STRICT CONFIDENTIAL	MODEL NO. F5F050-00AG	
		PART NO. P01AAA-7529JTE	
		DWG NO. P01AAA-7529JTE_I	
 Metric A4	TOLERANCES UNLESS OTHERWISE NOTED 0-6:±0.1, 6-120:±0.2, 120-315:±0.3, 315-∞:±0.5 ANGLES:±0.5°	TITLE: <b>I/O LABEL</b>	
 THIRD ANGLE PROJECTION	 SCALE : 1:1    SHEET 1 OF 3	DESIGNER	Eason
		CHECKED	Joe
		APPROVED	Arthur
			2023/11/22
			2023/11/22
			2023/11/22

來料圖面

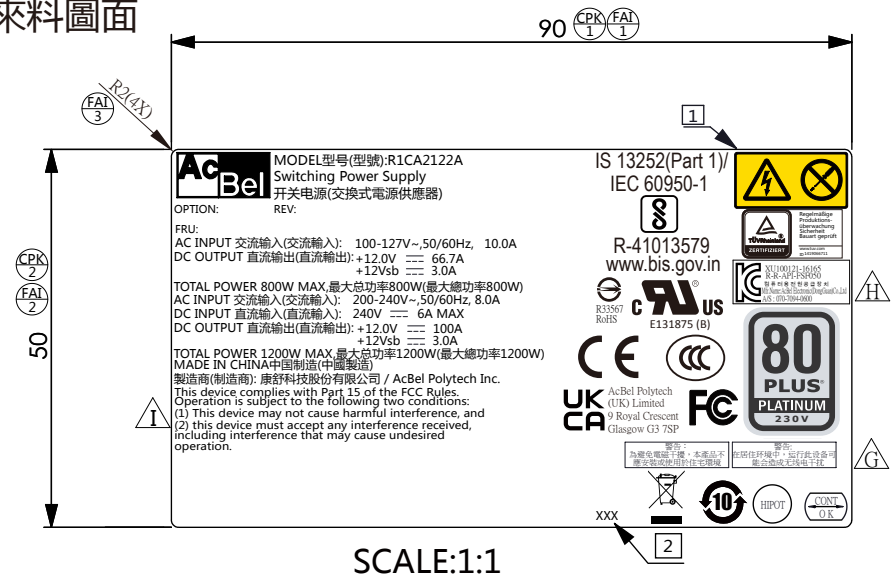

SCALE:1:1

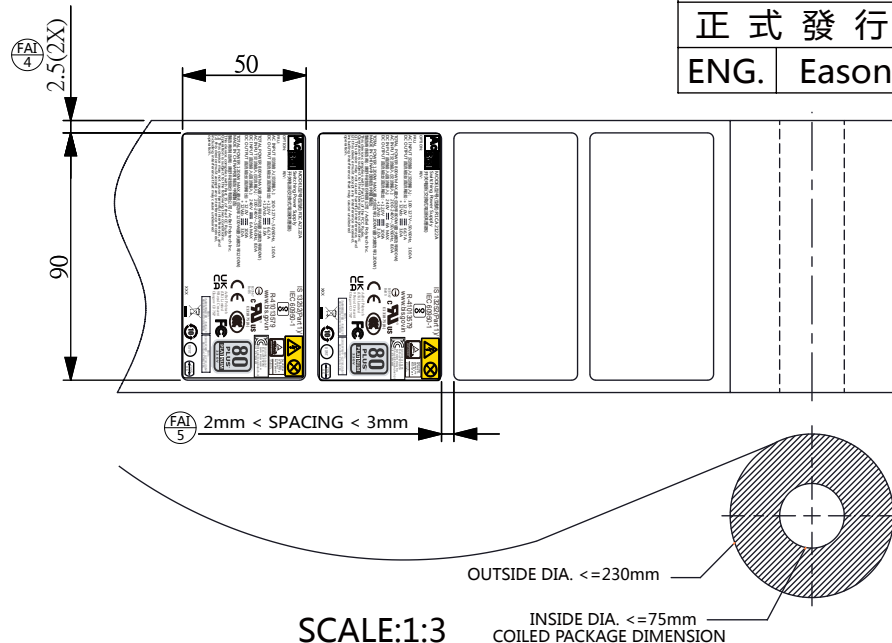

SCALE:1:3

RELEASE			
正式發行圖面		REV:I	
ENG.	Eason	APPR.	Arthur

SAFETY LOGO DETAIL  
SCALE:2:1

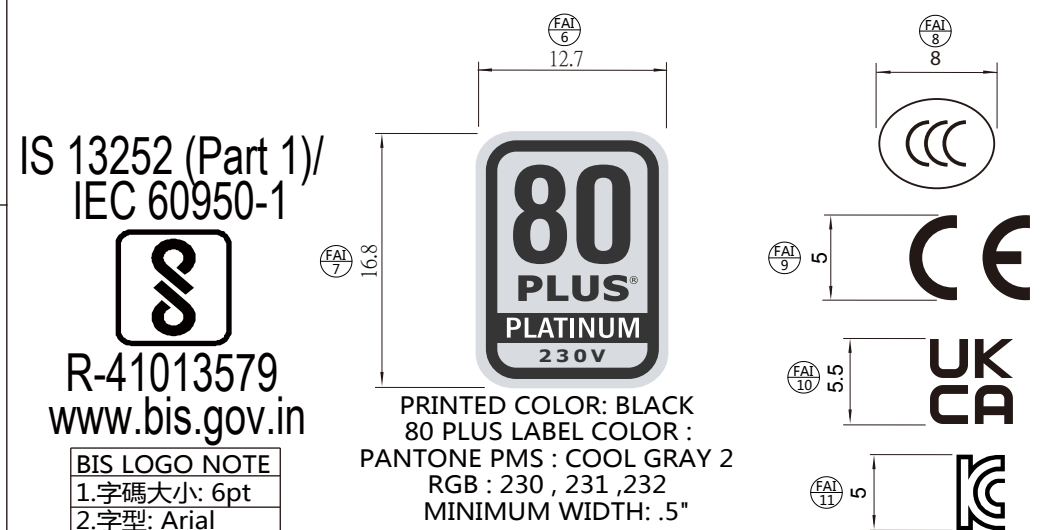

1. 警告符號顏色定義如下:  
PMC Black 黑色 - 文字 . 圖形 . 圖像 . 標誌  
PMC 108C 黃色 - 背景



2. LABEL MUST CONTAIN THE VENDOR'S ID MARK LOCATED IN THE AREA INDICATED.  
貼紙必須印製廠商代碼。

	DRAWINGS & SPEC. ARE THE EXCLUSIVE PROPERTY OF ACBEL POLYTECH INC. SAID ITEMS ARE ISSUED IN STRICT CONFIDENTIAL	MODEL NO. F5F050-00AG
		PART NO. P01AAA-7529JTE
ACBEL POLYTECH INC.		DWG NO. P01AAA-7529JTE_I
	TOLERANCES UNLESS OTHERWISE NOTED 0-6±0.1, 6-120±0.2, 120-315±0.3, 315--±0.5 ANGLES:±0.5°	TITLE: I/O LABEL
THIRD ANGLE PROJECTION		DESIGNER Eason 2023/11/22 CHECKED Joe 2023/11/22 APPROVED Arthur 2023/11/22
SCALE: 1:1	SHEET 2 OF 3	

# 打印內容

## 1 FRU自印原則:

AXXSSNNNNN

FW REVISION (印 : A000 ; A0001 ; A0002 ...Z9999)  
 MINOR REVISION (印 : 1 ; 2 ; 3 ...)  
 MAJOR REVISION (印 : 1 ; 2 ; 3 ...)  
 TYP (PMBUS印 : PM ; SMBUS印 : SM ; EEPROM印 : EP )  
 API

## 2 BAR CODE FORMAT: CODE 128 / CPI : 13.64

THE NARROW ELEMENT DIMENSION (X DIMENSION)  
 SHOULD BE WITHIN A RANGE OF 0.170MM  
 條碼格式:CODE 128/CPI 13.64寬/窄:0.17毫米(0.0067英寸)

## 3 REV:XXX (S1印:0S1;S2印:0S2;A印:A00)

## 4 REV/BARCODE/DATAMATRIX/FRU provide by sales/PM

REV/一維/二維/FRU 內容由業務/PM 提供

## 5 AcBel一維SN自印原則 :

OOOOOONNNZZZZXYWWSSSSSS

SERIAL NO 000001~999999  
 DATE CODE(YY:YEAR WW:WEEK)  
 MFG. FACTORY CODE:(東莞康舒印: B ; 東莞康展印: T ; 武漢康舒印: W )  
 ID CODE (EX:若機種為FSF050-00AG,則印製"00AG")  
 API REVISION CONTROL CODE(S1印 : 0S1 ; S2印 : 0S2)  
 API PN:(Ex.:若機種FSF050-00AG , 則印製"FSF050"於此6個欄位)

## 6 AcBel二維條碼自印原則:

條碼及文字內容說明  
 編碼:DATAMATRIX

XXXXXXXXXAAAA;OOOOOONNNZZZZXYWWSSSSSS;YYMMDD;XXXXXXXXXX

FRU (參照FRU自印原則)  
 生產日期 (例 : 2011年2月14日生產則印"110214")  
 MFG. FACTORY CODE:(東莞康舒印: B ; 東莞康展印: T ; 武漢康舒印: W )  
 OPTION  
 MODEL





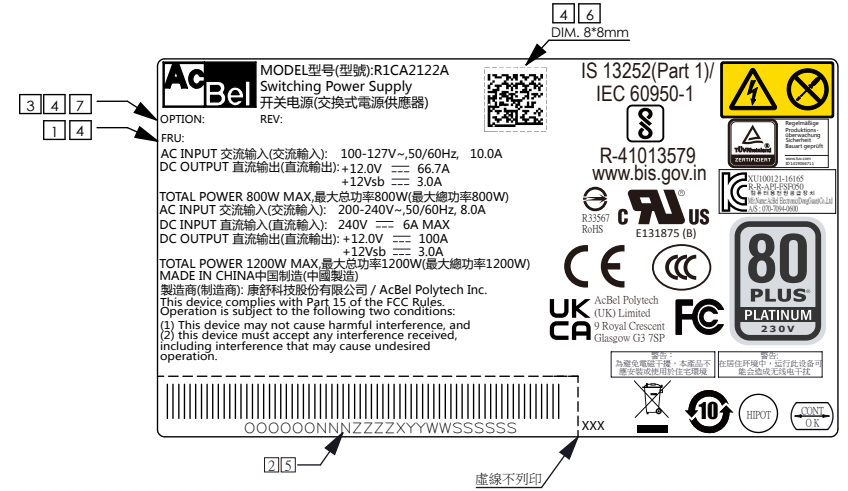





## 7 MODEL(型號)&OPTION PRINTED RULES:

機種	MODEL(型號)	OPTION
FSF050-00AG	R1CA2122A	P00A
FSF050-00CG	R1CA2122A	P00C
FSF050-4QAG	R1CA2122A	P4QA
FSF050-27AG	R1CA2122A	P27A
FSF050-38AG	R1CA2122A	P38A
FSF050-07DG	R1CA2122A	P07D
FSF050-000G	R1CA2122A	P000
FSF050-003G	R1CA2122A	P003
FSF050-07AG	R1CA2122A	P07A
FSF050-07BG	R1CA2122A	P07B
FSF050-07CG	R1CA2122A	P07C
FSF050-171G	R1CA2122A	P171
FSF050-610G	R1CA2122A	P610
FSF050-7KAG	R1CA2122A	P7KA
FSF050-9TAG	R1CA2122A	P9TA
FSF050-A2AG	R1CA2122A	PA2A
FSF050-GAAG	R1CA2122A	PGAA
FSF050-ZAAG	R1CA2122A	PZAA
FSF050-38BG	R1CA2122A	P38B
FSF050-CGAG	R1CA2122A	PCGA



RELEASE			
正式發行圖面		REV:I	
ENG.	Eason	APPR.	Arthur

ACBEL POLYTECH INC.	DRAWINGS & SPEC. ARE THE EXCLUSIVE PROPERTY OF ACBEL POLYTECH INC. SAID ITEMS ARE ISSUED IN STRICT CONFIDENTIAL	MODEL NO.	FSF050-00AG		
		PART NO.	P01AAA-7529JTE		
		DWG NO.	P01AAA-7529JTE_I		
		TITLE:	I/O LABEL		
SI Metric A4 TOLERANCES UNLESS OTHERWISE NOTED 0-6:±0.1, 6-120:±0.2, 120-315:±0.3, 315-:±0.5 ANGLES:±0.5° THIRD ANGLE PROJECTION	0 mm 25	DESIGNER	Eason	2023/11/22	
		CHECKED	Joe	2023/11/22	
SCALE : 1:1	SHEET 3 OF 3	APPROVED	Arthur	2023/11/22	

 <p><b>MODEL型号(型號):R1CA2122A</b> <b>Switching Power Supply</b> <b>开关电源(交換式電源供應器)</b></p> <p>OPTION: P00C REV:A04 FRU:APM12V0100</p> <p>AC INPUT 交流輸入(交流輸入): 100-127V~,50/60Hz, 10.0A DC OUTPUT 直流輸出(直流輸出): +12.0V <math>\equiv</math> 66.7A +12Vsb <math>\equiv</math> 3.0A</p> <p>TOTAL POWER 800W MAX,最大總功率800W(最大總功率800W) AC INPUT 交流輸入(交流輸入): 200-240V~,50/60Hz, 8.0A DC INPUT 直流輸入(直流輸入): 240V <math>\equiv</math> 6A MAX DC OUTPUT 直流輸出(直流輸出): +12.0V <math>\equiv</math> 100A +12Vsb <math>\equiv</math> 3.0A</p> <p>TOTAL POWER 1200W MAX,最大總功率1200W(最大總功率1200W) MADE IN CHINA中國製造(中國製造) 製造商(製造商): 康舒科技股份有限公司 / AcBel Polytech Inc. This device complies with Part 15 of the FCC Rules. Operation is subject to the following two conditions: (1) This device may not cause harmful interference, and (2) this device must accept any interference received, including interference that may cause undesired operation.</p>		<p>IS 13252(Part 1)/ IEC 60950-1</p>  <p>R-41013579 www.bis.gov.in</p>  <p>XU100121-16165 R-R-APT-FSF050 加拿大標準協會會員 Member: AcBel Electronics(DongGuan)Co.,Ltd A/S: 070-7094-0600</p>  <p>R33567 RoHS E131875 (B)</p>    <p>AcBel Polytech (UK) Limited 9 Royal Crescent Glasgow G3 7SP</p>  
	 <p>FSF050A0400CGB2314000001</p>	<p>警告: 為避免電磁干擾,本產品不 應安裝或使用於住宅環境</p> <p>警告: 在居住環境中,運行此設備可 能造成無線電干擾</p> 