



康舒科技

ACBEL POLYTECH INC.

Approval Sheet

Model No. : FSG032 Option 00AG
MKT Model No. : R1CA2801C Option T00A
Hardware Rev. : A01
Software Rev. : APM12V0005

Customer : PCICASE UK LTD
Customer PN : PM-A00000132_A0
PIZ2080R-95-ACB-S1

Approval by :

Smith Lu

Prepare by : **Vicki Wu**

Date: 8/15/2023



康舒科技

ACBEL POLYTECH INC.

Contents

- 1. Specification**
- 2. Mechanical Outline Drawing**
- 3. I/O Label Drawing**
- 4. Carton Drawing**
- 5. ATE test report**
- 6. Safety**



康舒科技

ACBEL POLYTECH INC.

Specification



ACBEL POLYTECH INC.



ACBEL POLYTECH INC.
康舒科技股份有限公司

159, Sec. 3, Tam-King Rd., Tamsui,
Taipei, Taiwan, 251 R.O.C.
Tel : (02)2623-7904~10 • 2621-7672~9
Sales DID : (02)2623-2750 • 2622-4300
Fax : ☐886-2-2623-6530 • 2623-4156

Specification for CRPS 800 Watts

Switching Power Supply

Model No.: FSG032-000G

Revision: A3.3

AcBel Polytech Inc.

Prepared By: Juxin Hsu

Approved By: Rossi Lo

Table of Contents

Table of Contents	2
1 Revision Log	5
2 Scope	6
2.1 Power Supply Overview	6
3 AC Input Requirements	6
3.1 Input Conditions	6
3.2 Input Fuse	7
3.3 Harmonic Current and Power Factor Correction	7
3.4 Input Connector	7
3.5 AC Line Isolation Requirements	7
3.6 AC Line Dropout / Hold up time	8
3.7 AC Line 12VSB Hold-up time	8
3.8 Inrush Current	8
3.9 Efficiency	9
3.10 AC Line Transient Specification	9
3.11 iTHD	9
3.12 Leakage Current	9
3.13 AC Line Transient, Compliance with EMC Standard	10
3.14 EMI	10
3.15 Voltage Interruptions	10
3.16 Power Recovery	10
4 DC Output Requirements	11
4.1 Voltage Regulation	11
4.2 Ripple /Noise	11
4.3 Dynamic Regulation	12
4.4 Immune Voltage	12
4.5 Capacitive Loading	12
4.6 Turn on/off Overshoot & Undershoot	13
4.7 Grounding	13
4.8 No Load Condition	13
4.9 Close Loop Stability	13
4.10 Remote ON/OFF	13
4.11 Common Mode Noise	14
4.12 Hot Swap Requirement	14
4.13 Output Isolation	14
4.14 Soft Starting	14
4.15 Force Load Share	14
4.16 Load Share Signal Characteristics	15
4.17 DC Connector and Pin Assignment	15
4.18 Handle Retention	16
4.19 LED Identification	16
5 Protection Requirements	17



5.1	Primary Protection	17
5.2	Secondary Protection	17
5.2.1	Current Limit (OCP & OPP).....	17
5.2.2	Over and Under Voltage Protection	17
5.2.3	Short Circuit Protection	18
5.2.4	Reset after Shutdown.....	18
5.2.5	Over Temperature Protection	18
6	Signal Requirement.....	19
6.1	PS_ON.....	19
6.2	Power Good (PWOK or P_GOOD)	20
6.3	PRESENT	20
6.4	Cshare signal.....	21
6.5	Sharing Accuracy.....	21
6.6	SMBAlert.....	21
6.7	Address_A0 / A1	22
6.8	PMBus CLOCK_SCL & DATA_SDA.....	22
6.9	REMOTE SENSE + / REMOTE SENSE -	23
6.10	Smart Redundant Bus	23
6.11	Standby Turn-off	23
6.12	Fan Speed Control.....	23
6.13	LED indicators	23
6.14	Timing.....	24
7	Additional Requirements	26
7.1	OTP	26
7.2	FAN FAIL.....	26
8	PMBus	27
8.1	PMBus specification	27
8.2	PMBus Command Default Value	27
9	Environmental Requirements	29
9.1	Temperature	29
9.1.1	Normal Operating Ambient (At Sea Level).....	29
9.1.2	Non-Operating Ambient (At Sea Level)	29
9.2	Humidity	29
9.2.1	Operating	29
9.2.2	Non-Operating	29
9.3	Altitude	29
9.3.1	Operating	29
9.3.2	Non-Operating	29
9.4	Mechanical Shock & Vibration	29
9.5	Thermal shock (none-operating)	30
10	Reliability	31
10.1	Reliability	31
10.2	E-Cap Life	31
10.3	MTBF.....	31
10.4	De-Rating Guideline	31
11	EMC and Safety Requirements.....	32



ACBEL POLYTECH INC.



ACBEL POLYTECH INC.
康舒科技股份有限公司

159, Sec. 3, Tam-King Rd., Tamsui,
Taipei, Taiwan, 251 R.O.C.
Tel : (02)2623-7904~10 • 2621-7672~9
Sales DID : (02)2623-2750 • 2622-4300
Fax : ☐886-2-2623-6530 • 2623-4156

11.1	Safety Mark and Standards	32
11.2	EMI Requirement	32
11.3	Immunity Against.....	32
11.4	Hi-pot.....	32
12	Mechanical Drawing.....	33

CONFIDENTIAL DOCUMENT

1 Revision Log

Revision	Description	Approved	Date
A0	Initial Release		20160926
A1	Modify section 3.10 AC line sag and surge test condition.		20170629
A1	Modify section 3.6 hold up time		20170629
A1	Modify section 6.14 timing		20170629
A1	Modify section 8.3 PMBus command table		20170629
A1	Add section 12.1 Mechanical drawing		20170629
A1.1	3.1 Input condition : add 240Vdc input		20170802
A1.1	Modify 9.1.1 normal operating ambient to 55degC		20170816
A1.1	Modify 4.3 Dynamic regulation slew rate to 0.5A/us		20170816
A2	Section 8 PMBus follow FW SPEC		20171025
A2.1	Modify section 6.12 Fan Speed Control: The airflow direction shall be from the card edge connector to the AC inlet side of the power supply.		20171116
A2.2	MFR_TAMBIENT_MAX 50degC→55degC		20171212
A2.2	Update 12 Mechanical Drawing		20171212
A3	Delete section 3.1 note		20180129
	Modify section 3.16 description		
	Delete section 4.5 Capacitive Loading (defined by capacitance and ESR)		
	Modify section 4.6 description		
	Delete section 4.10 note		
	Modify section 5.1 description		
	Modify item 5.2.1 description		
	Modify item 5.2.3 description		
	Add item 5.2.4 note		
	Modify section 6.4 description		
	Modify section 6.5 description		
	Modify section 6.6 description		
Modify section 6.9 description			
Modify section 10.1 description			
A3.1	Modify section 4.17 pin assignment: B25 is NC pin		20190729
A3.2	Remove section 6.13 LED indication UVW condition		20220922
A3.3	Update section 12 Mechanical Drawing, Latch color change to PANTONE 369C		2023/05/12



2 Scope

This specification establishes the requirements for a custom “1U” form factor, 800 Watts output, active power factor corrected, and wide-range power supply. Also, the approximate dimensions are 73.5mm(W) x 185mm(D) x 40mm(H). The power supply will be used in 1+1 redundant (load share) and must contain appropriate Or-ing devices on all outputs . The number of PSU would be limited to two.

2.1 Power Supply Overview

Application	Sever System	
AC Input & DC input	100-240VAC, 240VDC	
Power Factor Correction	Active	
Output Power	800 Watts maximum continuous	
EMC Classification	EN61000-4-5 2KV common mode, 1KV Differential mode 'UL/cUL, TUV, CB, CE, BSMI, CCC,	
Outputs	12V	12V Standby
Nominal Output Voltage	12.00	12.00
Voltage Regulation	±5%	±5%
Minimum Operating Current	0.5 A	0.1 A
Maximum Operating Current	65 A	2 A

3 AC Input Requirements

3.1 Input Conditions

AC input Parameter	Minimum	Nominal	Maximum	Unit
Low Line	90	100-127	140	Vac rms
High Line	180	200-240	264	Vac rms
Frequency	47	50/60	63	Hz
lin			11	A rms
Turn-on	81	85	89	Vac rms
Turn-off	70	75	80	Vac rms
Vin_OVP	300			Vac rms

DC input Parameter	Minimum	Nominal	Maximum	Unit
Voltage(Vdc)	180	240	300	Vdc
Turn-on	166	170	175	Vdc
Turn-off	156	160	165	Vdc

3.2 Input Fuse

A normal-fast-blow, high-breaking-capacity fuse must be placed in the single line fuse on the line/hot wire of the AC input. AC inrush does not cause the ac line fuse to blow under any condition. All protection circuits in the power supply do not cause the ac fuse to blow unless a component in the power supply has failed.

3.3 Harmonic Current and Power Factor Correction

The power supply shall incorporate universal power input with active power factor corrections, which shall reduce line harmonics in accordance with the [EN61000-3-2](#) and [JEIDA MITI](#) standards.

The power factor lists as below..

Load	10%	20%	50%	100%
P.F.	>0.9	>0.96	>0.98	>0.99

Tested at 115VAC/60Hz and 230VAC/50Hz

3.4 Input Connector

The AC input receptacle shall be an IEC-320 type C14 capable of at least 15A at 120VAC rating and 10A at 240VAC rating. This connector is located at the frond side of power supply. There is a retainer to fix the line cord to avoid accident disconnection,

3.5 AC Line Isolation Requirements

The power supply shall meet all safety agency requirements for dielectric strength. Additionally, power supply vendor must provide Intel with written confirmation of dielectric withstand test which includes: voltage level, duration of test and identification detailing how each power supply is marked to indicate dielectric withstand test had been completed successfully. Transformers' isolation between primary and secondary windings must comply with the 3000Vac (4242Vdc) dielectric strength criteria. If the working voltage between primary and secondary dictates a higher dielectric strength test voltage the highest test voltage should be used. In addition the insulation system must comply with reinforced insulation per safety standard IEC 950. Separation between the primary and secondary circuits, and primary to ground circuits, must comply with the IEC 950 spacing requirements.

3.6 AC Line Dropout / Hold up time

An AC line dropout is defined to be when the AC input drops to 0VAC at any phase of the AC line for any length of time. During an AC dropout the power supply must meet dynamic voltage regulation requirements. An AC line dropout of any duration shall not cause tripping of control signals or protection circuits. If the AC dropout lasts longer than the hold up time the power supply should recover and meet all turn on requirements. The power supply shall meet the AC dropout requirement over rated AC voltages and frequencies. A dropout of the AC line for any duration shall not cause damage to the power supply.

Loading during AC dropout / holdup	Holdup time / Dropout duration
100% of rated load	10msec, alert drop<4ms

3.7 AC Line 12VSB Hold-up time

The 12VSB output voltage should stay in regulation under its full load (static or dynamic) during an AC dropout of **70ms min** (=12VSB holdup time) whether the power supply is in ON or OFF state (PSON asserted or de-asserted).

3.8 Inrush Current

The power supply shall provide circuitry to limit the turn-on inrush current on any initial current surge or spike will not exceed 55A peak.

Notes:

1. The inrush current due to the EMI filter capacitors can be ignored.
2. All internal components (including the fuse, bulk rectifiers and surge limiting device) must be able to withstand the surge current without damage the power supply.
3. The inrush limiting circuitry shall be designed such that if the active bypass circuitry is not functional the remaining circuitry shall not cause any smoke/flame potential safety issue.
4. The inrush current must meet at cold/warm start.

3.9 Efficiency

The Power supply shall meet 80 plus Titanium efficiency requirement at 230Vac.

Loading	10%	20%	50%	100%
Minimum Efficiency	90%	94%	96%	92%

Note:

- Fan loading is not included for efficiency measurements. Efficiency to be measured at 20-25C after supply has run for 30 minutes.

3.10 AC Line Transient Specification

AC line transient conditions shall be defined as “sag” and “surge” conditions. “Sag” conditions are also commonly referred to as “brownout”, these conditions will be defined as the AC line voltage dropping below nominal voltage conditions. “Surge” will be defined to refer to conditions when the AC line voltage rises above nominal voltage.

The power supply shall meet the requirements under the following AC line sag and surge conditions.

AC Line Sag (10 sec interval between each sagging)				
Duration	Sag	Operating AC Voltage	Line Frequency	Performance Criteria
0 to 1/2 AC cycle	95%	Nominal AC voltage ranges	50/60Hz	No loss of function or performance.
> 1 AC cycle	>30%	Nominal AC voltage ranges	50/60Hz	Loss of function acceptable ,self-recoverable

AC Line Surge (10 sec interval between each surging)				
Duration	Surge	Operating AC Voltage	Line Frequency	Performance Criteria
continuous	10%	Nominal AC voltages	50/60Hz	No loss of function or performance.
0 to 1/2 AC cycle	30%	Mid-point of nominal AC voltages	50/60Hz	No loss of function or performance.

3.11 iTHD

This test shall be measured at 115VAC/60Hz and 230VAC/50Hz

Load	10%	20%	50%	100%
iTHD	<20%	<10%	<8%	<5%

3.12 Leakage Current

Maximum input leakage current at 240VAC, 50Hz, shall not exceed 0.875mA

3.13 AC Line Transient, Compliance with EMC Standard

Power supply shall operate within specifications under the followings conditions:

- a) Transients as defined in IEC61000-4-4, Electrical Fast Transients standard, up to 1KV at AC line.
- b) Transients as defined in IEC61000-4-5, Electrical Surge standard.

Common mode 2.0KV

Differential mode 1.0KV

- c) Power supply shall comply with IEC61000-4-2, Electrostatic Discharge standard, up to 8KV with contact, 15KV with air discharge.
- d) Power supply shall meet all the transient requirements for the CE mark designation.

3.14 EMI

The power supply shall comply with FCC and EN55022 (CISPR22) Class A for conducted and radiated emissions. It must comply at 100-127, 200-240VAC/50Hz with 6dB margin as minimum.

3.15 Voltage Interruptions

The power supply shall comply with the limits defined in EN55024: 1998/A1: 2001/A2: 2003 using the IEC 61000-4-11: Second Edition: 2004-03 test standard and performance criteria C defined in Annex B of CISPR 24.

Performance criteria C, Temporary loss of function is allowed provided the function is self-recoverable or can be restored by the operation of the controls.

3.16 Power Recovery

The power supply shall recover automatically after an AC power failure. AC power failure is defined to be any loss of AC power that exceeds the dropout criteria stated in section 3.6.

4 DC Output Requirements

4.1 Voltage Regulation

The power supply output voltages must stay within the following voltage limits when operating at steady state and dynamic loading conditions. +12V are measured with reference to the return remote sense (12VSB) signal. The +12VSB, +12V outputs are measured at the power supply connectors referenced to DC Return.

	Min	Nom	Max	Tolerance
+12V	11.4V	12.0V	12.6V	+5% / -5%
+12VSB	11.4V	12.0V	12.6V	+5% / -5%

4.2 Ripple /Noise

The maximum allowed ripple and noise output of the power supply is defined in as below table. This is measured over a bandwidth of 1Hz to 20MHz at the power supply output connector. A 10 μ F ceramic capacitor in a parallel with a 0.1 μ F ceramic capacitor are placed at the point of measurement.

Outputs	Maximum	Unit
12V Standby	120	mVp-p
+12V	120	

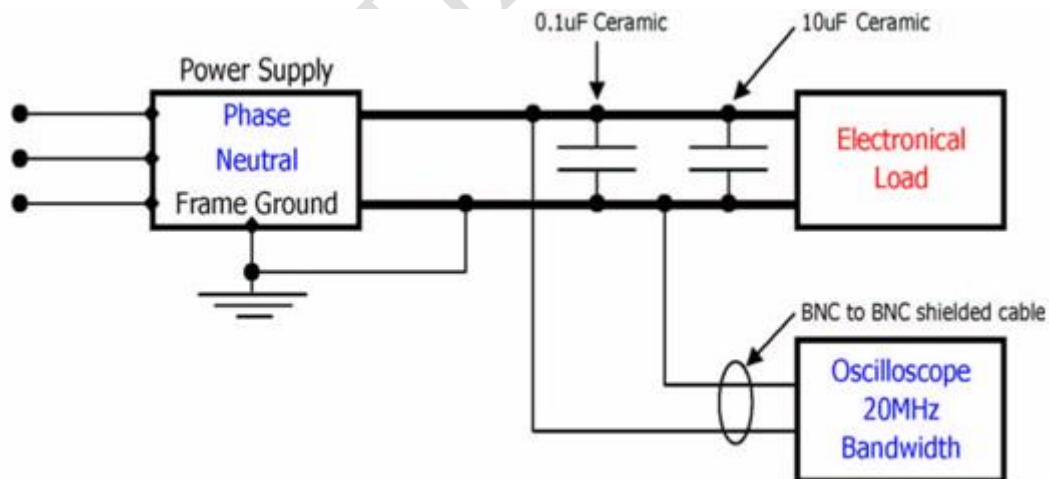

Notes:

1. Output ripple & noise should be measured at the pins of the mating output connector.
2. Connect the probe with the input tip and ground as short as possible.
3. Output ripple & noise measured with only PSU capacitance plus 10uF Ceramic and 0.1uF Ceramic.
4. Ripple & noise are defined as periodic or random signals over the frequency band of 1Hz to 20MHz.

4.3 Dynamic Regulation

The output voltage shall remain within the limits specification in section 4.1 **Voltage Regulation** for the step loading and within the limit specification in below table for the capacitive loading. The load transient repetition rate shall be tested between 50Hz and 10kHz at duty cycles ranging from 10% - 90%. The load transient repetition rate is only a test specification. The step load may occur anywhere within the Min Load to the Max Load show in below table. During +12V output load changes from minimum to maximum or maximum to minimum, the power supply must not shut down.

Outputs ¹	Step Load Size	Slew Rate	Test Capacitor load
+12V	50%	0.5A/uS	2200 uF
+12VSB	50%	0.5A/uS	100 uF

Note: for dynamic condition +12V min loading is 1A.

4.4 Immune Voltage

The PSU should be immune to any residual voltage placed on its outputs (typically a leakage voltage through the system from standby output) up to 500mV. There shall be no additional heat generated, nor stressing of any internal components with this voltage applied to any individual or all outputs simultaneously. It also should not trip the protection circuits during turn on.

The residual voltage at the power supply outputs for no load condition shall not exceed **500mV** when AC voltage is applied and the PSON# signal is de-asserted.

4.5 Capacitive Loading

The PSU will be able to power up and operate normally with the capacitive load on the DC outputs, the power supply shall be stable and meet all requirements with the following capacitive loadings.

Outputs	MIN	MAX	Units
+12VSB	10	3,100	uF
+12V	100	25,000	uF

4.6 Turn on/off Overshoot & Undershoot

During the turn-on or turn-off stage, the output voltage overshoot during turn-on of any of the output, including the standby output, under any of the conditions specified in temperature section 9.1 and capacitive loading section 4.5 will less than 10% above the nominal voltage and will settle into the regulation band within 20ms.

The output voltage undershoot during turn-off of any of the output, including the Standby output, under any of the condition specified in temperature section 9.1 and capacitive loading section 4.5

There must be a smooth and continuous ramp of each output voltage from 10% to 95% of its final set point within the regulation band. No voltage of opposite direction will be present on any output during turn-on or turn-off stage.

4.7 Grounding

The output ground of the pins of the power supply provides the output power return path. The output connector ground pins shall be connected to the safety ground (power supply enclosure). This grounding should be well designed to ensure passing the max allowed Common Mode Noise levels.

4.8 No Load Condition

This condition shall not trip any failure circuitry shutdown or cause any permanently damaged to the power supply. Also, the power supply shall normal operate when the power supply is turn on or when the power supply is already on at no load condition.

When the power supply is subsequently loaded, it must begin to regulate and source current without fault.

4.9 Close Loop Stability

The power supply shall be unconditionally stable under all line/load/transient load condition including capacitive load. A minimum of 45 degrees phase margin and -10dB gain margin is required.

The power supply manufacturer shall provide proof of the unit's closed-loop stability with local sensing through the submission of Bode plots.

Bode Plot documentation will have Phase and Gain margin data, line and load conditions, as well as the oscillator injection level. For verification purposes the plots will have the method of test and injection points clearly documented on a current schematic. Stability plots need to be provided at both the upper and lower operating temperature limits.

4.10 Remote ON/OFF

Differential (Single ended) remote sense is to be provided for the designated remote sense outputs. The remote sense must be able to compensate for the defined system output voltage drop over the system output resistance (after the output connector).

The remote sense lines must be protected such that if only the remote sense is connected to the load, or there is a short across the remote sense, the power supply is not damaged.

4.11 Common Mode Noise

The Common Mode noise on any output shall not exceed **350mV pk-pk** over the frequency band of 10Hz to 20MHz.

1. The measurement shall be made across a 100Ω resistor between each of DC outputs, including ground at the DC power connector and chassis ground (power subsystem enclosure).
2. The test set-up shall use a FET probe such as Tektronix model P6046 or equivalent

4.12 Hot Swap Requirement

Hot swapping a power supply is the process of inserting and extracting a power supply from an operating system. During this process, the output voltage shall remain within the regulation limits specified in section 4.1 with capacitive load specified in section 4.5. The hot swap test must be conducted when the system is operating under static, dynamic condition and zero loading condition. The power supply should use a latching mechanism to prevent insertion and extraction of the power supply when AC power cord is inserted into the power supply.

4.13 Output Isolation

All outputs have an isolating device to isolate the power supply from the system power during a power supply failure or during a hot swap operation. This device is located in power supply. This device is an or'ing diode or functional equivalent.

4.14 Soft Starting

The Power Supply shall contain control circuit which provides monotonic soft start for its outputs without overstress of the AC line or any power supply components at any specified AC line or load conditions.

4.15 Force Load Share

The 12V main will have active load sharing. The output will share within +/-5% at 50%-100% load, +/-10% at 20-50% load. The failure of a power supply should not affect the load sharing or output voltages of the other supplies still operating and does not cause these outputs to go out of regulation in the system.

The power supplies must be able to load share with up to 2 power supplies in parallel.

The 12V standby output is passive sharing. The 12VSB of power supplies are connected together in the system, so that a failure or hot swap of a redundant power supply does not cause these outputs to go output of regulation in the system.

4.16 Load Share Signal Characteristics

The load share signal is only for the load function. The load share signal characteristics is defined as below table.

Item	Description	Min	Nominal	Max
Vshare; I _{ou} =Max	Voltage of load share bus at specified maximum output current	7.76V	8.0V	8.24V
ΔVshare / I _{out} ; I _{out} >1A	Slope of load share bus voltage with changing load		8.00/I _{max} V/A	
I _{share sink} ; Vshare=4.00V	Amount of current the load share bus output from each power supply sources.			0.5mA
I _{share source} Vshare=4.00V	Amount of current the load share bus output from each power supply sinks.	4mA		

4.17 DC Connector and Pin Assignment

Pin No.	Pin Name	Pull up resistor	Pin Length	Description
A1~A9 B1~B9	GND	N/A	Standard	12V main & 12VSB Return
A10~A18 B10~B18	12V	N/A	Standard	12V main output
A19	SDA	10K ohm is pulled high to 3.3V(damping 47 ohm)	Short	SMBus/PMBus Data
A20	SCL	10K ohm is pulled high to 3.3V(damping 47 ohm)	Short	SMBus/:PMBus Clock
A21	PSON	20K ohm is pulled high to 3.3V	Standard	Active low; 12V main output on/off control
A22	SMBAlert	N/A	Short	Active low; alert signal (interrupt)
A23	RETURN_S	N/A	Standard	12V main output Remote Sense -
A24	+12VRS	N/A	Standard	12V main output remote sense +
A25	PWOK	34 ohm is pulled high to 3.3V, 820	Standard	Active high; indicate 12V main is valid



ACBEL POLYTECH INC.



ACBEL POLYTECH INC.
康舒科技股份有限公司

159, Sec. 3, Tam-King Rd., Tamsui,
Taipei, Taiwan, 251 R.O.C.
Tel : (02)2623-7904~10 • 2621-7672~9
Sales DID : (02)2623-2750 • 2622-4300
Fax : ☐886-2-2623-6530 • 2623-4156

		ohm is pulled low to GND		
B19	A0	20K ohm is pulled high to 3.3V	Standard	PMBus address 0
B20	A1	20K ohm is pulled high to 3.3V	Standard	PMBus address 1
B21	12VSB	N/A	Standard	Standby voltage
B22	CR	N/A	Standard	Cold Redundancy Bus
B23	12VLS	N/A	Standard	12V main output load current sharing
B24	Present	N/A	Standard	Power Supply Present
B25	NC	N/A	Standard	NC pin

Note: Refer to the spec of CRPS Common Requirements specification

4.18 Handle Retention

The power supply shall have a handle to assist extraction. The module shall be able to be inserted and extracted without the assistance of tools. The power supply shall have a latch which retains the power supply into the system and prevents the power supply from being inserted or extracted from the system when the AC power cord is pulled into the power supply.

4.19 LED Identification

The power supply shall use a bi-color LED; Amber & Green.

5 Protection Requirements.

5.1 Primary Protection

The supply must have internal primary over current protection. A normal blow (fast blow), high-breaking-capacity fuse must be placed in the line side of the input circuit. This fuse is not to be considered replaceable for purposes of determining power supply reliability and life as specified in Section 10.

If any component on the line side of the fuse is shorted or opened, it shall not cause a fire or any other safety risk.

5.2 Secondary Protection

5.2.1 Current Limit (OCP & OPP)

The power supply shall have current limit to prevent the outputs from exceeding the values shown in table below. If the current limits are exceeded the power supply shall shutdown and latch off. The latch will be cleared by an AC power interruption or PS_ON cycle on/off. The power supply shall not be damaged from repeated power cycling in this condition.

12VSB will be auto-recovered after removing OCP limit.

Outputs	Status	Output Current Range			Minimum Keep time	SMBAlert	SMBAlert Mode
		Minimum	Normal	Maximum			
+12VSB	OCP	2.5A	-	4A	-	-	-
+12V	OC Warning	102%	105%	108%	continuous	10~30 ms	1. SMBAlert Can recovery within keep time of +12V. 2. SMBAlert is latch mode when power shutdown but can be de-assert by system.
	OCP1	110%	112%	115%	2sec	10~30 ms	
	OCP2	115%	120%	135%	65ms	10~30 ms	
	OPP	135%	145%	155%	100usec	<20usec	

5.2.2 Over and Under Voltage Protection

Outputs	Under Voltage		Over Voltage		Unit
	Minimum	Maximum	Minimum	Maximum	
+12VSB	10	11	13.0	14.5	V
+12V	10	11	13.0	14.5	V

Notes:

- The above OV/UV test will be satisfied throughout AC input in section 3.1 and the entire operating temperature range in section 9.1
- Standby output shall not latch off due to an under/over voltage condition.
- A fault on any output other than Standby will not cause the Standby to turn off. Also, that fault on Standby will cause the other outputs to turn off but not latch off.
- The power supply will provide latch mode except for Standby output.

5.2.3 Short Circuit Protection

A short circuit is considered to be resistance of 0.1 ohms or less, applied to any output during start-up or while running will not cause any damage to the power supply (connectors, components, PCB traces, etc.).The power supply shuts down and latches off for short on main outputs but recovers upon PS_ON assertion or AC toggle after short circuit removed.

When the Standby output is shorted the output may go into “hiccup mode”, and all outputs shuts down upon a short circuit of the 12VSB. When the short is removed on 12VSB, the power supply shall recover automatically.

5.2.4 Reset after Shutdown

If the power supply latches into a shutdown state due to a fault condition on main output, the power supply will return to normal operation only after the fault has been removed and the power supply has been power- cycled. Both methods of resetting the power supply shall be designed into the supply so that the user may choose which method to use.

Reset can be accomplished in one of two ways as below:

- a) Removing AC input power, waiting for Standby output to drop below 1.0V, then reapplying AC power.
The time it takes for Standby output to drop below 1.0V shall not exceed 15 seconds.
- b) Cycling the state of PS_ON from on to off to on. The minimum cycle time will be 100mS.

Notes : The above-mentioned fault conditions on main output include OVP 、 UVP 、 OCP and OPP.

5.2.5 Over Temperature Protection

The power supply will be protected against over temperature conditions caused by loss of fan cooling or excessive ambient temperature. In an OTP condition the PSU will shut down. When the power supply temperature drops to within specified limits, the power supply shall restore power automatically. The OTP circuit must have built in hysteresis such that the power supply will not oscillate on and off due to temperature recovering condition. The OTP trip level shall have a minimum of 4°C of ambient temperature hysteresis.

Ambient temperature	MIN	MAX
Over temp warning(OTW)	61°C	63°C
Over temp shutdown (OTP)	65°C	67°C

6 Signal Requirement

This requirement shall be met throughout the load regulation condition specified in section 4.1, under all input voltage condition specified in section 3.1 and temperature condition specified in section 9.1.

6.1 PS_ON

The PS_ON signal is required to remotely turn on/off the power supply. PS_ON is an active low signal that turn on the main power rails. When this signal is not pulled low by the system, or left open, the outputs turn off.

The power supply shall provide an internal pull-up to high. The power supply shall also provide de-bounce circuitry on PS_ON to prevent it from oscillating On/Off at startup when activated by mechanical switch.

Provisions for de-bouncing will be included in the PS_ON circuitry to prevent the power supply from oscillating on/off at startup.

Signal type	Accepts an open collector/drain input from the system Pull-up to internal 3.3V located in power supply	
PS_ON =Low	PSU On	
PS_ON =Open or High	PSU Off	
	MIN	MAX
Logic level low (PSU ON)	0 V	0.495 V
Logic level high (PSU OFF)	2.64V	3.46V
Source current, Vpson= low		4mA
Power up delay:	5 ms	400 ms

6.2 Power Good (PWOK or P_GOOD)

This signal should be asserted high by the power supply to indicate that all outputs are within the regulation thresholds listed in section 4.1. Conversely, this signal should be de-asserted to a low state when any of the DC outputs voltage falls below its under voltage threshold, or when mains power has been removed for a time sufficiently long so that power supply operation can't be guaranteed. This signal must be driven low at least 1ms before any of the outputs go out of regulation.

Signal type	Refer to the below PWOK circuit	
POK or P_Good =High	DC Outputs O.K.	
POK or P_Good =Low	DC Outputs N.G.	
	Minimum	Maximum
Logical Level Low, Isink =400uA	0 V	0.4V
Logical Level High, Isource =200uA	2.0V	3.46V
Sink current, PWOK=low		400uA
Source current, PWOK=high		2mA
PWOK delay: Tpwok_on	100 ms	500 ms
Power down delay: Tpwok_off	1 ms	
POK or P_Good Rise & Fall Time		100us

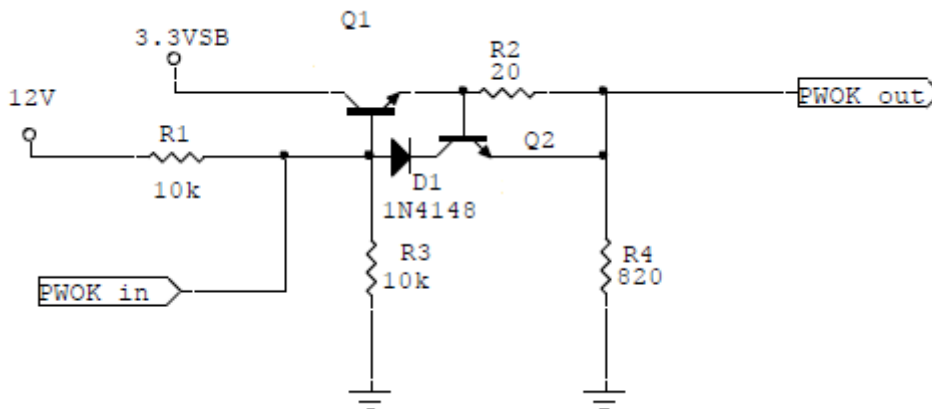

Notes : The circuit is for reference only.

6.3 PRESENT

This pin will be tied to Standby return through a 0 ohms resistor.

6.4 Cshare signal

This input /output will allow two power supplies to share output current between them, if one of the supplies fails the remaining supplies must pick up the entire load without any of the outputs dropping out of regulation. A defective supply that is connected to the output voltage bus will not have adverse effect on the operation of the remaining function supplies.

Total Load	Number of supplies	Cshare (V) Minimum	Cshare Nominal	Cshare (V) Maximum
100%	2	3.8	4	4.2
50%	2	1.8	2	2.2
20%	2	0.64	0.8	0.96
100%	1	7.76	8	8.24
50%	1	3.8	4	4.2
20%	1	1.4	1.6	1.8
0%	1	0	0	0.3

6.5 Sharing Accuracy

12V output should share load averagely and meet tolerance from full load to 20% load.

Load	Sharing Accuracy
50-100%	±5%
20-50%	±10%

Note 1 : Sharing accuracy is not measured under transient conditions, but under transient conditions a false over current fault must not occur.

Note 2 : Current sharing is not required power on of the outputs until the P.G. signal is asserted (all outputs are valid.)

6.6 SMBAlert

This signal indicates that the power supply is experiencing a problem that the user should investigate, simultaneously the signal be asserted in parallel with LED turning solid Amber or blink Amber. The SMB_Alert signal may be asserted by the PSU as below cases. Please refer to the firmware specification for detail.

1. STATUS_INPUT (UV Fault),
2. STATUS_IOUT (Iout OC Warning),
3. STATUS_TEMPERATURE (OT Warning)

Signal type	Open collector / drain output from power supply. Pull-up to 3.3V located in power supply	
SMBAlert=High	OK	
SMBAlert=low	Power Alert to system	
	Minimum	Maximum
Logical Level Low, Isink=4mA	0 V	0.4V
Logical Level High, I sink=50uA	2.64V	3.6V
Sink current, Alert# = low		4mA
Sink current, Alert# = high		50uA
Alert# rise and fall time		100us

6.7 Address_A0 / A1

This signal is defined by end user system for PMBus communication, to allocate address of power supply unit in particular slot location

This signal have a pull-up resistor to internal 3.3V located in power supply.

Signal type	Input pin ,Pull-up to internal 3.3V located in power supply	
SMB Adress_A0/A1=high	Address 1	
SMB Adress_A0/A1 =low	Address 0	
	Minimum	Maximum
Logical Level Low	0 V	0.4V
Logical Level High	2.64V	3.57V

6.8 PMBus CLOCK_SCL & DATA_SDA

SCL is the SMBus clock input to the supply,

SDA is the bi-directional SMBus data path to /from the supply.

Both have a pull-up resistor to 3.3V internal located in power supply. The pull-up must be diode isolated to prevent an unpowered/ faulted supply from loading the signal. It must be designed to not glitch bus during hot plug and unplugging.

The PMBus operation frequency is 100kHz.

It shall conform to SMBus V2.0 signaling protocol standards. And this specification is based on the PMBus specification parts I and II, revision 1.2.

Note: All I2C devices will be powered from the outside of the standby Oring-device. This will allow the status to be read from a supply that is not powered on, or has some other fault. Some types of protection must be provided so a fault within the supply does not take down the bus.

6.9 REMOTE SENSE + / REMOTE SENSE -

These signal are analog In/Output 12V Main Voltage Sense. Both are analog input/output voltage sense lines to compensate for power path voltage drop. These low level analog signals should be isolated from digital circuit noise. When one or more remote sense lines are opened, regulation measured at the power supply output connector must be maintained within regulation defined. If the REMOTE SENSE+ is shorted to DC_RETURN, the main 12V output shall go over-voltage and the power supply will shut down.

6.10 Smart Redundant Bus

This signal should be connected together at system board for smart redundant function. Please refer to the firmware specification for detail.

6.11 Standby Turn-off

Following removal of AC power, the Standby output will remain at its steady state value until such time as it begins to decrease in voltage. The decrease will be monotonic in nature dropping to 0.5 volts or less. There will be no other perturbations of this voltage at, or following, removal of AC power.

6.12 Fan Speed Control

The power supply shall incorporate a 40x28mm fan for cooling the power supply when installed in the system. The airflow direction shall be from the card edge connector to the AC inlet side of the power supply. The Fan speed control must have close loop algorithm based on both the critical component temperature and the ambient temperature. Thus ensure the PSU Fan will always ramp to maximum speed under any condition to protect the power supply from overheating. These conditions include high ambient temperatures; loading, AC input, and airflow impedance.

After the new load and/or cooling condition steady state is established, transition to the steady state fan speed shall take place within 60 seconds.

6.13 LED indicators

The power supply may have a single Bi-color (Green-Amber) Configuration.

Power Supply Condition	LED State
Output ON and OK	GREEN
No AC power to all power supplies	OFF
AC present / Only 12VSB on (PS off) or PS in Smart redundant state / Off line mode	1Hz Blink GREEN



ACBEL POLYTECH INC.



ACBEL POLYTECH INC.
康舒科技股份有限公司

159, Sec. 3, Tam-King Rd., Tamsui,
Taipei, Taiwan, 251 R.O.C.
Tel : (02)2623-7904~10 • 2621-7672~9
Sales DID : (02)2623-2750 • 2622-4300
Fax : ☐886-2-2623-6530 • 2623-4156

AC cord unplugged or AC power lost; with a second power supply in parallel still with AC input power.	AMBER
Power supply warning events where the power supply continues to operate; high temp, high power, high current, slow fan	1Hz Blink Amber
Power supply critical event causing a shutdown; failure, OCP, OVP, Fan Fail	AMBER
Power supply FW updating	2Hz Blink GREEN

6.14 Timing

These are the timing requirements for the power supply operation. The output voltages must rise from 10% to within regulation limits (T_{vout_rise}) within 2 to 70ms. For 12VSB, it is allowed to rise from 1.0 to 25ms. **All outputs must rise monotonically.** Table below shows the timing requirements for the power supply being turned on and off via the AC input, with PSON held low and the PSON signal, with the AC input applied.

ITEM	DESCRIPTION	MIN	MAX	UNIT
T12Vsb_rise	Output voltage rise time for 12VSB	1	25	ms
T12V_rise	Output voltage rise time for 12V	2	70	ms
Tsb_on_delay	Delay from AC being applied to 12VSB being within regulation.		1500	ms
T ac_on_delay	Delay from AC being applied to all output voltages being within regulation.		3000	ms
Tvout_holdup	Time 12V output voltage stay within regulation after loss of AC.	11		ms
Tpwok_holdup	Delay from loss of AC to de-assertion of PWOK.	10		ms
Tpson_on_delay	Delay from PSON# active to output voltages within regulation limits.	5	400	ms
T pson_pwok	Delay from PSON# deactivate to PWOK being de-asserted.		5	ms
Tpwok_on	Delay from output voltages within regulation limits to PWOK asserted at turn on.	100	500	ms
T pwok_off	Delay from PWOK de-asserted to output voltages dropping out of regulation limits.	1		ms
Tpwok_low	Duration of PWOK being in the de-asserted state during an off/on cycle using AC or the PSON signal.	100		ms
Tsb_vout	Delay from 12VSB being in regulation to O/Ps being in regulation at AC turn on.	50	1000	ms
T12VSB_holdup	Time the 12VSB output voltage stays within regulation after loss of AC.	70		ms



ACBEL POLYTECH INC.



ACBEL POLYTECH INC.
康舒科技股份有限公司

159, Sec. 3, Tam-King Rd., Tamsui,
Taipei, Taiwan, 251 R.O.C.
Tel : (02)2623-7904~10 • 2621-7672~9
Sales DID : (02)2623-2750 • 2622-4300
Fax : ☐886-2-2623-6530 • 2623-4156

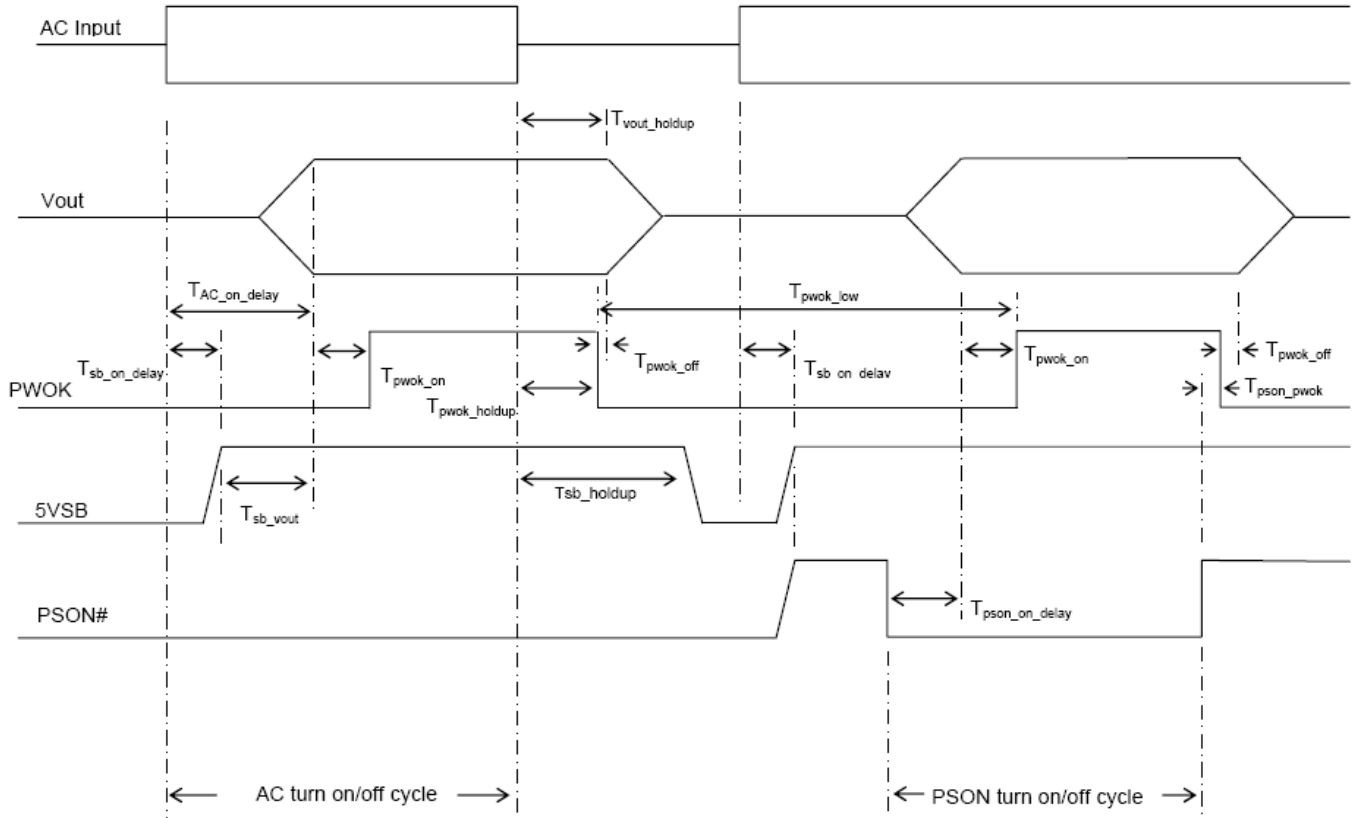

CONFIDENTIAL

7 Additional Requirements

7.1 OTP

The power supply shall incorporate a thermal shutdown feature that turns off all outputs (except Standby output) When an over temperature condition occurs, the power supply will not be damaged and will automatically restart when the over temp condition no longer exists. Hysteresis shall be employed to prevent a frequent toggling on and off of the outputs.

The location of the OTP sensor should be on the component(s) most likely to overheat in the event of an abnormal ambient temperature or a blockage of airflow.

In normal operation the OTP cannot activate when the power supply is operated in any of the specified operating conditions of sections 3.1, 4.1, and 9.1.

POK must be low for at least 1mS before the main outputs go out of regulation.

7.2 FAN FAIL

The fan(s) are running or the supply is in Standby mode. If there is a fan fault per section 6.12, the PSU is off and the POK must be low for at least 1mS before the main outputs go out of regulation.

The PSU will shutdown when fan failed (<800rpm) during 10~15 sec.



ACBEL POLYTECH INC.



ACBEL POLYTECH INC.
康舒科技股份有限公司

159, Sec. 3, Tam-King Rd., Tamsui,
Taipei, Taiwan, 251 R.O.C.
Tel : (02)2623-7904~10 • 2621-7672~9
Sales DID : (02)2623-2750 • 2622-4300
Fax : ☐886-2-2623-6530 • 2623-4156

8 PMBus

8.1 PMBus specification

**** PMBus compliance please refers to firmware specification ****

8.2 PMBus Command Default Value

CMD code	CMD name	Power On Default Value
40h	VOUT_OV_FAULT_LIMIT	14V
44h	VOUT_UV_FAULT_LIMIT	10.5V
46h	IOUT_OC_FAULT_LIMIT	72.75A
4Ah	IOUT_OC_WARN_LIMIT	68A
51h	OT_WARN_LIMIT	100C
5Bh	IIN_OC_FAULT_LIMIT	12.5A
5Dh	IIN_OC_WARN_LIMIT	High Line = 5.5A, Low Line = 11A HVDC = 5.5A
68h	POUT_OP_FAULT_LIMIT	1000W
6Ah	POUT_OP_WARN_LIMIT	840W
6Bh	PIN_OP_WARN_LIMIT	940W
99h	MFR_ID	"ACBEL POWER"
9Ah	MFR_MODEL	"FSG032-000G"
9Bh	MFR_REVISION	"XX"



ACBEL POLYTECH INC.



ACBEL POLYTECH INC.
康舒科技股份有限公司

159, Sec. 3, Tam-King Rd., Tamsui,
Taipei, Taiwan, 251 R.O.C.
Tel : (02)2623-7904~10 • 2621-7672~9
Sales DID : (02)2623-2750 • 2622-4300
Fax : ☐886-2-2623-6530 • 2623-4156

		XX=00~99
9Ch	MFR_LOCATION	"TAIWAN" or "CHINA"
9Dh	MFR_DATE	YYMM
9Eh	MFR_SERIAL	FSG032YYWWSS SSSSRR (Follow Acbel Label bar code rule)
A0h	MFR_VIN_MIN	AC:90V, HVDC:180V
A1h	MFR_VIN_MAX	AC:264V, HVDC:300V
A2h	MFR_IIN_MAX	HighLine:5A, LowLine:10A, HVDC: 5A
A3h	MFR_PIN_MAX	900W
A4h	MFR_VOUT_MIN	11.4V
A5h	MFR_VOUT_MAX	12.599V
A6h	MFR_IOUT_MAX	65A
A7h	MFR_POUT_MAX	800W
A8h	MFR_TAMBIENT_MAX	55C
ABh	MFR_EFFICIENCY_HL	230V, 160W, 94%, 400W, 96%, 800W, 91%
ADh	IC_DEVICE_ID	"PIC24FJ64GA00 6 "
C0h	MFR_MAX_TEMP_1 (Ambient)	61°C (OTW Threshold)
C1h	MFR_MAX_TEMP_2 (Hot Spot)	100°C (OTW Threshold)
C2h	MFR_MAX_TEMP_3 (Primary)	100°C (OTW Threshold)
C3h	MFR_FAN_SPEED_MAX	25344rpm
C4h	MFR_FAN_SPEED_MIN	192rpm
C5h	MFR_PSU_Defined	E8h

9 Environmental Requirements

9.1 Temperature

9.1.1 Normal Operating Ambient (At Sea Level)

+0°C minimum.

+55°C maximum.

Maximum rate of change is 10°C/hr.

9.1.2 Non-Operating Ambient (At Sea Level)

-40°C minimum to +70°C maximum. Maximum rate of change is 20°C/hr.

9.2 Humidity

9.2.1 Operating

5 to 85% relative humidity. (Non-Condensing)

9.2.2 Non-Operating

Up to 95% relative humidity. (Non-Condensing)

9.3 Altitude

9.3.1 Operating

-50 to 16,405 feet (5,000 meters),

9.3.2 Non-Operating

-50 to 50,000 feet (15,240 meters)

9.4 Mechanical Shock & Vibration

Unpackage Shock

Operation Shock	Shock Type	Peak(G)	Velocity Change(m/s)	Duration(ms)	Apply side
	Half-Sine	10	-	6	50 shocks on each faces
Non-Operation Shock	Shock Type	Peak(G)	Velocity Change(m/s)	Duration(ms)	Apply side
	Half-Sine	30	-	18	3 shocks on each faces

Unpackage Vibration

Operation Vibration

Vibration Type	Start(Hz)	End(Hz)	Peak(G)	Grms	Apply side	Duration(min)/axes
Random	10	500	-	0.78	3 axes	30

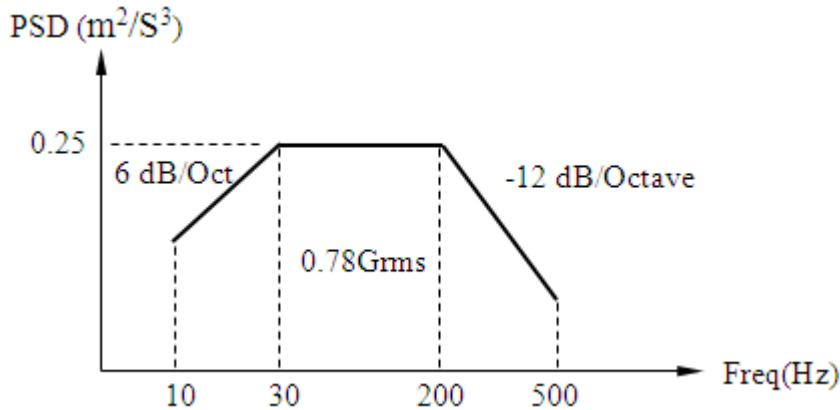

Non-Operation Vibration

Vibration Type	Start(Hz)	End(Hz)	Peak(G)	Grms	Apply side	Duration(min)/axes
Random	10	500	-	1.56	3 axes	30

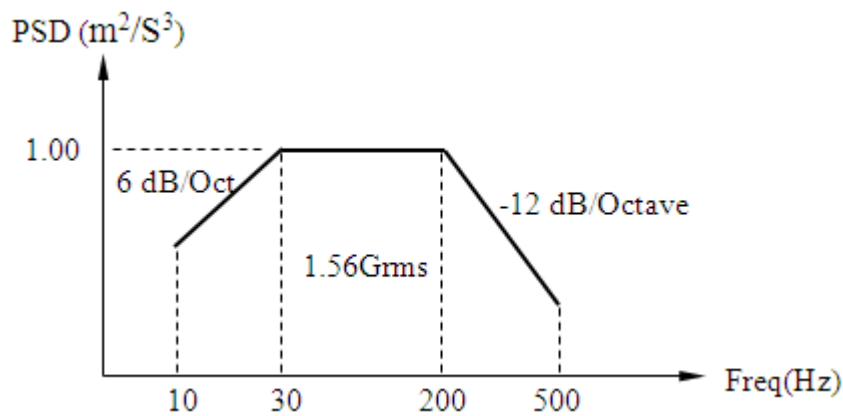

9.5 Thermal shock (none-operating)

-40°C minimum to +70°C maximum, transition time not to exceed 5 minutes. Duration of exposure to temperature extremes will be 20 minutes

10 Reliability

10.1 Reliability

The reliability requirements are based on the following product usage/application conditions.

AC Input Voltage Range	Refer to Section 3.1
DC Output Load	100% Maximum of rate output load
Temperature Range	Refer to Section 9.1
Relative Humidity	44% ±10% Non-condensing
Altitude	Sea Level
MTBF	200K Hours,100% load at 50°C
E-Cap Life	>3years ,at full load with 40 degree C. 100Vac
Minimum Operating Life	5 Years

10.2 E-Cap Life

All used electrolytic caps must have a usefully life time which exceeds 3 year at 100% load and normal input and 40°C power supply ambient temperature.

10.3 MTBF

The power supply shall have a minimum MTBF at continuous operation of.

- 1) 200,000Hours at 100% load and 50°C, as calculated by Bell core RPP.
- 2) 200,000Hours demonstrated at 100% load and 50°C

10.4 De-Rating Guideline

Refer to AcBel component de-rating.

11 EMC and Safety Requirements

The power supply must comply with all regulatory requirements for its intended geographical market. Depending on the chosen market, regulatory requirements may vary. Although a power supply can be designed for worldwide compliance, there may be cost factors that drive different versions of supplies for different geographically targeted markets. The power supply meets below standard, and the mark.

11.1 Safety Mark and Standards

UL/cUL, UL 60950-1;
TUV, EN 60950-1.
CB, IEC 60950-1
CE, IEC 60950-1
BSMI, CNS 14336, CNS 13438;
CCC(5000meter), GB4943.1-2011, GB9254, GB17625.1.

11.2 EMI Requirement

The power supply meet EMI standard as below, need margin 6dB
EN55022 Class A.
CISPR22 Class A.
FCC Class A.

11.3 Immunity Against

The power supply meet immunity requirements specified in EN55024, EMS standard as below.
IEC/EN 61000-4-2 ESD, (contact 8kV, air 15kV).
IEC/EN 61000-4-4 Transient/burst (1kV).
IEC/EN 61000-4-5 Surge immunity, 1kV Differential Mode 2kV Common Mode.

11.4 Hi-pot

The power supply unit must pass a 2121Vdc Residual Voltage test between primary to chassis ground.



ACBEL POLYTECH INC.



ACBEL POLYTECH INC.
康舒科技股份有限公司

159, Sec. 3, Tam-King Rd., Tamsui,
Taipei, Taiwan, 251 R.O.C.
Tel : (02)2623-7904~10 • 2621-7672~9
Sales DID : (02)2623-2750 • 2622-4300
Fax : 886-2-2623-6530 • 2623-4156

12 Mechanical Drawing

12 11 10 9 8 7 6 5 4 3 2 1

NOTES: 單位:毫米
 1. UNIT: MM. 單位:毫米
 2. UNITS ARE IN METRIC.
 3. SQCC G30/COMPL WITH ASTM A653 G30.
 4. 72 HOURS MINIMUM WHITE RUST PROTECTION IN SALT SPRAY (ASTM B117) MATERIAL MUST MEET DC CONDUCTIVITY REQUIREMENTS FOR ELECTRICAL CONDUCTIVITY REQUIREMENTS.
 5. 72小時鹽霧試驗(ASTM B117), 材料標準率DC阻抗需小於 0.1 OHMS MAX.
 6. SQCC/熱浸鍍鍍層 G30(符合ASTM A653 G30) 至少72小時鹽霧試驗(ASTM B117), 材料標準率DC阻抗需小於 0.1 OHMS MAX.
 7. NET WEIGHT: 940g ± 3%
 8. 淨重: 940g ± 3%
 9. DIMENSION: L=185.0 W=73.5 H=40.0
 10. 外觀尺寸: 長185.0 寬73.5 高40.0
 11. THE APPEARANCE OF THE FAN IS ONLY FOR REFERENCE.
 12. 風扇的外觀以實際樣品為準。
 13. FOR REFERENCE ONLY. SUBJECT TO ACTUAL PRODUCT.
 14. 僅供參考, 以實物為準。
 15. ④ FAIL IS THE CRITICAL DIMENSION, FOR EVERY SHIPMENT, MUST FULLY INSPECT THREE SAMPLE PARTS AND PROVIDE A REPORT. THE REPORT MUST BE VALIDATED. ④ FAIL IS THE CRITICAL DIMENSION, FOR EVERY SHIPMENT, MUST FULLY INSPECT THREE SAMPLE PARTS AND PROVIDE A REPORT. THE REPORT MUST BE VALIDATED.
 16. ④ FAIL IS THE CRITICAL DIMENSION, FOR EVERY SHIPMENT, MUST FULLY INSPECT THREE SAMPLE PARTS AND PROVIDE A REPORT. THE REPORT MUST BE VALIDATED.
 17. ④ FAIL IS THE CRITICAL DIMENSION, FOR EVERY SHIPMENT, MUST FULLY INSPECT THREE SAMPLE PARTS AND PROVIDE A REPORT. THE REPORT MUST BE VALIDATED.
 18. ④ FAIL IS THE CRITICAL DIMENSION, FOR EVERY SHIPMENT, MUST FULLY INSPECT THREE SAMPLE PARTS AND PROVIDE A REPORT. THE REPORT MUST BE VALIDATED.
 19. ④ FAIL IS THE CRITICAL DIMENSION, FOR EVERY SHIPMENT, MUST FULLY INSPECT THREE SAMPLE PARTS AND PROVIDE A REPORT. THE REPORT MUST BE VALIDATED.
 20. SCREW THREAD MUST BE WITHSTAND THE FOLLOWING TORQUE INDICATED:
 螺絲鎖付扭矩力需大於下列數值:
 M3 0.5 12KG-CM(MIN)
 M3.5 0.6 15KG-CM(MIN)
 #4-30 1.0 15KG-CM(MIN)
 #4-40 1.5 15KG-CM(MIN)
 21. STUD AND CLINCH NUT MUST BE FLUSH ON THE NOTED SURFACE WHICH MUST BE CONFORM TO THE FOLLOWING TORQUE INDICATED:
 螺絲鎖付或螺帽需符合下列扭矩力值:
 SHEET MATERIAL
 HOT-DIPPED SHEET 熱浸鍍層板
 PUSH-OUT TORQUE OUT (KG-CM/MIN) 47
 (KG-CM/MIN) 15
 (KG-CM/MIN) 30
 M3 0.5 0.6 ~ 1.0
 #5-32 50
 M4 0.7 50

12 11 10 9 8 7 6 5 4 3 2 1

12 11 10 9 8 7 6 5 4 3 2 1

RELEASE

正式發行圖面	REV.B
ENG. EASON	APPR. RAY

更新	更新內容	更新日期
A	PRIMAARILY	EASON 20231117
1	RELEASE	EASON 20231117

更新	更新內容	更新日期
A2	MECHANICAL OUTLINE	EASON 20230812

SCALE: 1:1 SHEET 1 OF 2

12 11 10 9 8 7 6 5 4 3 2 1



ACBEL POLYTECH INC.



ACBEL POLYTECH INC.
康舒科技股份有限公司

159, Sec. 3, Tam-King Rd., Tamsui,
Taipei, Taiwan, 251 R.O.C.
Tel : (02)2623-7904~10 • 2621-7672~9
Sales DID : (02)2623-2750 • 2622-4300
Fax : 886-2-2623-6530 • 2623-4156

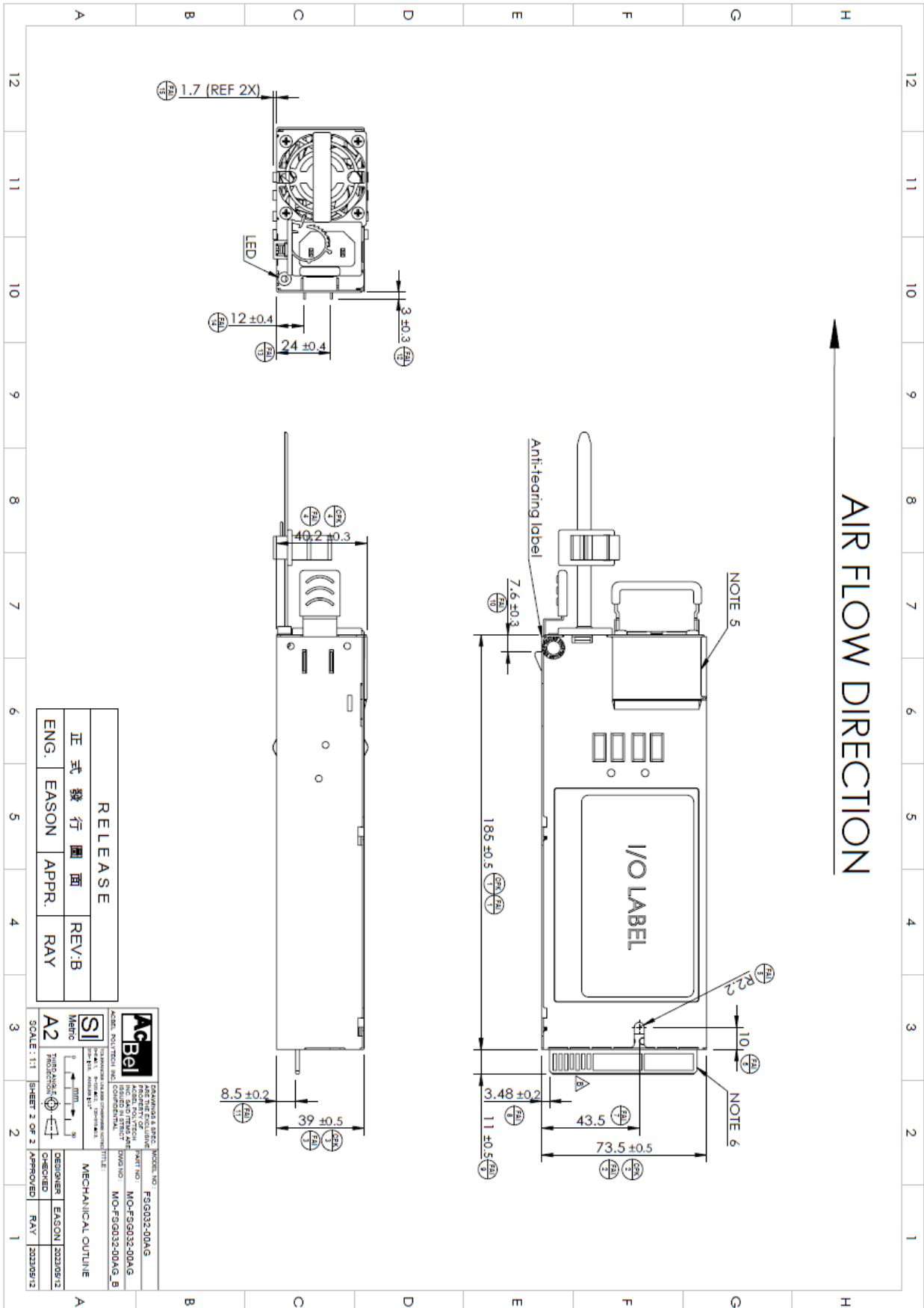

RELEASE			
正式發行圖面	REV/B		
ENG. EASON	APPR. RAY		

AcBel MECHANICAL OUTLINE

SCALE: 1:1 SHEET 2 OF 2 APPROVED

DESIGNER	EASON	20230812
CHECKED	RAY	20230812

MODEL NO. FS9332-00A.G
PART NO. MO-FS9332-00A.G
DRAWING NO. MO-FS9332-00A.G_B



ACBEL POLYTECH INC.



ACBEL POLYTECH INC.
康舒科技股份有限公司

159, Sec. 3, Tam-King Rd., Tamsui,
Taipei, Taiwan, 251 R.O.C.
Tel : (02)2623-7904~10 • 2621-7672~9
Sales DID : (02)2623-2750 • 2622-4300
Fax : ☐886-2-2623-6530 • 2623-4156

End of document.

CONFIDENTIAL DOCUMENT



康舒科技

ACBEL POLYTECH INC.

Mechanical Outline Drawing

NOTE:
 1 ENCLOSURE MATERIAL :
 SGCC G30(COMPLY WITH ASTM A653 G30).
 72 HOURS MINIMUM WHITE RUST PROTECTION IN
 SALT SPRAY (ASTM B117). MATERIAL MUST MEET
 DC RESISTANCE 0.1 OHMS MAX. FOR ELECTRICAL
 CONDUCTIVITY REQUIREMENTS
 機殼材質:
 SGCC(熱浸鋅鋼板)G30(符合ASTM A653 G30)
 至少72小時鹽霧防護處理(ASTM B117). 材料導電率DC阻
 抗需小於 0.1 OHMS MAX

2 ALL EXPOSED EDGES MUST BE MEET HANDLING
 REQUIREMENTS SPECIFIED IN UL 1439 AND DO NOT
 CUT THROUGH THE FIRST LAYER OF THE TESTER
 所有可能被觸碰的邊緣必須符合 UL1439 觸摸安全需求,
 不可以割破檢測物的第一層

3 FAI CPK "CRITICAL DIMENSION SYMBOL",
 SUPPLIER MUST INSPECT THIS DIMENSION FOR EVERY
 SHIPMENT.

FAI CPK "表示該(尺寸/位置)為設計之重點尺寸,
 供應商每次出貨前必須檢驗合格方可出貨。

4 DO NOT ALLOW SCRATCH ON THE SURFACE. EXTRUDE
 PORTION SHOULD PREVENT THE DAMAGE OF THE ZINC
 PLATED LAYER AND OXIDATION
 表面不允許刮傷,抽孔/擠出成型部份也必須防止電鍍層有
 氧化現象

5 THE MANUFACTURER SHALL NOTIFY ACBEL PRIOR TO
 CHANGES IN MANUFACTURING LOCATION
 製造商如需變更製造地,需事先通知ACBEL

6 THESE MATERIAL/PART/ASSEMBLY MUST BE COMPLIED
 TO ACBEL SPEC "CRITERIA FOR ENVIRONMENT-
 RELATED SUBSTANCES"
 材質/零件/製程均必須符合康舒"環境管理物質規範"

7 ALL REF DIMENSIONS MUST BE COMPLIED TO
 MECHANICAL OUTLINE DRAWING REQUIREMENT
 所有參考尺寸必須符合MO實際組裝要求

8 BARCODE LABEL, WARNING LABEL AND INFORMATION
 LABEL SHOULD BE LOCATED ON NOTED SURFACE
 ,BEFORE ADHERING LABELS, SHEET METAL SURFACE
 MUST BE FREE OF ANY GREASE, OIL AND DIRT
 標籤粘貼的位置如圖示.在粘貼前,金屬表面必須沒有任何的
 油污,油,或是塵土

9 GROUND SYMBOL MUST BE LOCATED TO THE
 PERMANENTLY MARKED NEAR PRIMARY GROUND
 CONNECTION.
 接地符號 需永久的位於一次側接地處

10 MATERIAL THICKNESS:0.8mm
 MATERIAL SUPPLIER
 PRIMARY SOURCE : CHINA STEEL
 ALTERNATE SOURCE :
 YIEH PHUL BAO STEEL, WISCO
 材料厚度:0.8mm
 鋼板材料優先製造商:
 第一優先:中鋼
 第二順位:燐鐵,寶鋼,武鋼

11 COVER , CHASSIS & SIDE PANEL MUST BE THE
 SAME COLOR UNLESS OTHERWISE SPECIFIED.
 除非有特別指示,否則上蓋、下蓋、邊板必須顏色一致

12 NET WEIGHT: 925 GRAMS±3%
 淨重:925 克±3%

13 RADUS SHOULD BE R0.5MM UNLESS OTHERWISE
 SPECIFIED.
 未標示R角皆為0.5mm.

14 SPOT WELDING & RIVETS MUST BE ABLE TO
 WITHSTAND A PULLING FORCE OF 20Kgf-cm MIN.
 焊接或鉚接強度需大於20Kgf-cm的拉力

15 UNIT : MM
 單位:毫米

16 NONE-SPECIFIED DIMENSIONS MUST BE COMPLIED
 TO 3D MODEL
 未標示尺寸必須符合3D模型要求。

17 SCREW THREAD MUST BE WITHSTAND THE
 FOLLOWING TORQUE INDICATED :
 螺紋鎖付扭轉抗力需大於下列數值:
 M3 * 0.5 12kgf-cm(MIN)
 M3.5 * 0.6 15kgf-cm(MIN)
 #6-32 12kgf-cm(MIN)

18 STUD AND CLINCH NUT MUST BE FLUSH ON THE
 NOTED SURFACE WHICH MUST BE CONFORM TO
 THE FOLLOWING TORQUE INDICATED :
 鉚接螺絲或螺帽,需符合下表扭力值:

THREAD CODE 螺紋編號	SHEET THICKNESS 板厚(MM)	SHEET MATERIAL 鋼板材質	
		HOT-DIPPED SHEET 熱浸鍍板	
		PUSHOUT 推出抗力 (Kg MIN)	TORQUE OUT 扭轉抗力 (Kg MIN)
M3 * 0.5	0.8 - 1.0	47	15
#6-32		50	18
M4 * 0.7		50	30

19 THE APPEARANCE OF THE FAN IS ONLY FOR REFERENCE
 風扇的外觀以實際樣品為準

20 FOR REFERENCE ONLY.SUBJECT TO ACTUAL PRODUCT
 僅供參考.以實物為準

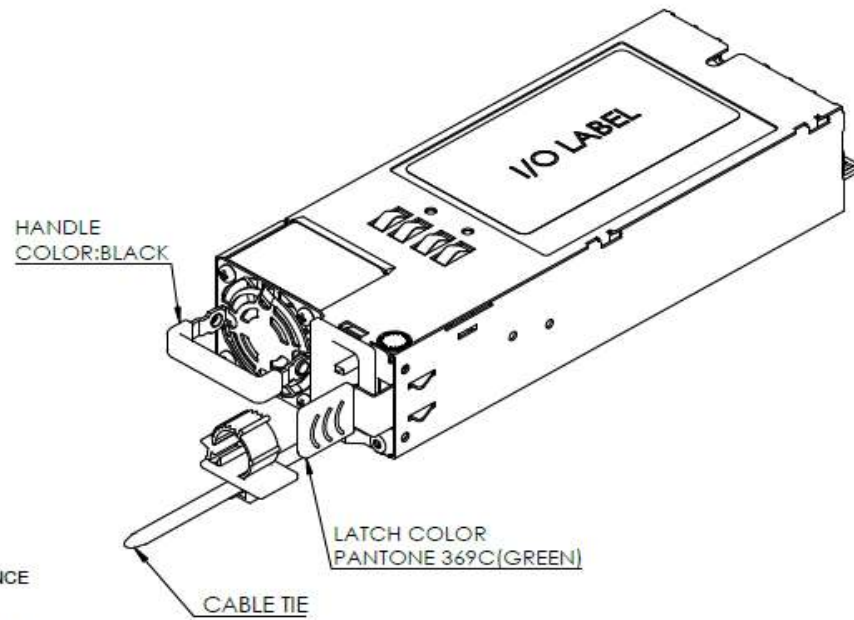

RELEASE			
正式發行圖面			REV:A
ENG.	EASON	APPR.	RAY

A	RELEASE	EASON	20220117
1	PRIMARY	EASON	20220117
REV	DESCRIPTION	BY	DATE

 ACBEL POLYTECH INC. TEL: 886-2-2611-1111 FAX: 886-2-2611-1112 312-30A, ANGELES CITY	DRAWINGS & SPEC. ARE THE EXCLUSIVE PROPERTY OF ACBEL POLYTECH INC. SAID ITEMS ARE ISSUED IN STRICT CONFIDENTIAL	MODEL NO.: FSG032-00AG PART NO.: MO-FSG032-00AG DWG NO.: MO-FSG032-00AG_A
	TITLE: MECHANICAL OUTLINE	
	DESIGNER EASON 2022/1/17 CHECKED RAY 2022/1/17 APPROVED	

 Metric A2 SCALE 1:1 SHEET 1 OF 2	 THIRD ANGLE PROJECTION
---	-------------------------------

12 11 10 9 8 7 6 5 4 3 2 1

APR 12
 RELEASE
 MO-FSG032-00AG_01
 3058.6 3.00Tsun.Ten

AIR FLOW DIRECTION

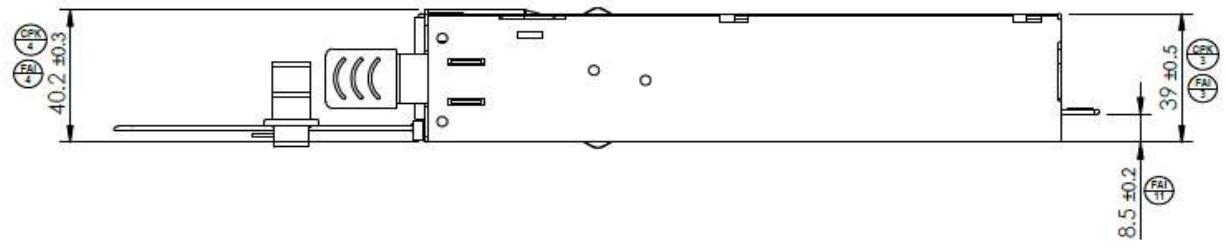
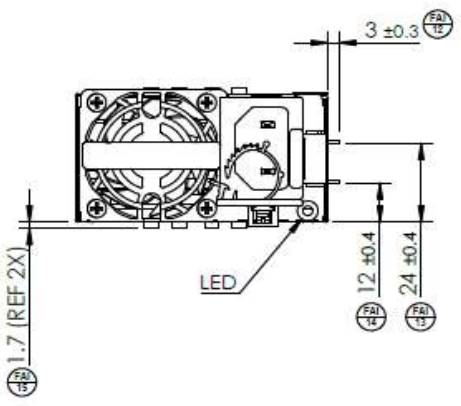
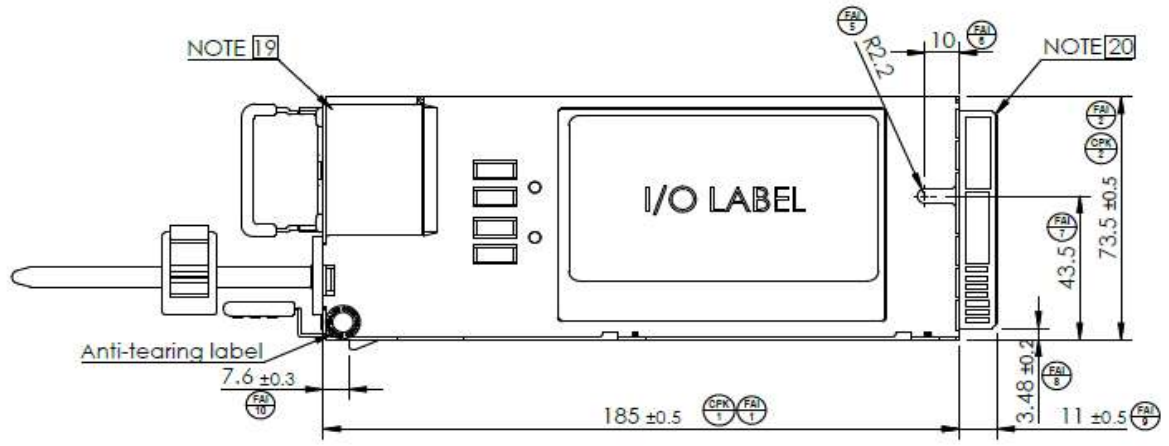

RELEASE

正式發行圖面

ENG. EASON APPR. RAY

REV:A

 ACBEL POLYTECH INC.	DRAWINGS & SPEC. ARE THE EXCLUSIVE PROPERTY OF ACBEL POLYTECH INC. SAID ITEMS ARE ISSUED IN STRICT CONFIDENTIAL.	MODEL NO: FSG032-00AG PART NO: MO-FSG032-00AG DWS NO: MO-FSG032-00AG_A
	TOLERANCES UNLESS OTHERWISE NOTED: DIM. 0-12.5mm 12.5-25mm 25-50mm FIT-MAX. ANGLES 45°	TITLE: MECHANICAL OUTLINE
 Metric A2 THIRD ANGLE PROJECTION	DESIGNER EASON 2022/1/17 CHECKED RAY 2022/1/17	SCALE: 1:1 SHEET 2 OF 2 APPROVED

12 11 10 9 8 7 6 5 4 3 2 1



康舒科技

ACBEL POLYTECH INC.

I/O Label Drawing

NOTE:
 1 UNIT : MM
 單位 : 毫米

2 MATERIAL (材料):
 2.1 FACE STOCK(底材):
 WHITE POLYESTER FILM, (白麥拉)
 THICKNESS = 0.05 MM(厚度=0.05毫米)

2.2 ADHESIVE(背膠):
 THICKNESS = 0.025 MM(厚度=0.025毫米)
 PRESSURE SENSITIVE ACRYLIC(背膠)

2.3 BACKED WITH RELEASE LINER(背面附離型紙)

2.4 LABEL TO BE AFFIXED TO AND MAXIMUM TEMPERATURE RATING: GALVANIZED STEEL 100°C
 貼紙所貼附之材質與最大耐溫等級: 鍍鋅鋼, 100°C

2.5 MATERIAL MUST BE UL RECOGNIZED AND COMPLY TO UL 969 STANDARD
 材質必須符合UL認證, 並且遵從969標準

13 SN BARCODE FORMAT: CODE 128/CPI: 13.64
 THE NARROW ELEMENT DIMENSION(X DIMENSION) SHOULD WITHIN RANGE OF 0.170MM(0.0067INCH)
 條碼格式: CODE 128/ CPI 13.64
 寬/窄比: 0.17毫米(0.0067英寸)

14 WARNING LABEL PRINTED COLOR:
 警告符號顏色定義:
 PMC BlackC黑色 - 文字、圖形、圖像、標誌
 PMC 108C 黃色 - 背景



15 DATA IDENTIFIER : XX.XX.XX
 FIELD TITLE : FW REV NUMBER
 FIELD LENGTH : 8-10 CHARACTERS.
 資料鑑別: XX.XX.XX
 標題區: 版本號碼
 長度區: 8-10字元

16 條碼自印原則
 條碼及文字內容說明
 編碼: DATAMATRIX

XXXXXXXXXX;AAAYYWWSSSSSSZZZXNNNNNN;YYMMDD;XXXXXXXXXX

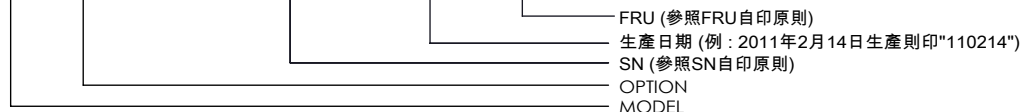

3 LABEL MUST BE MADE BY A UL RECOGNIZED AND CSA APPROVED VENDOR.
 貼紙之製造商必須是UL與CSA所認證

4 FAI (FAI), CPK (CPK), " (") "CRITICAL DIMENSION SYMBOL ,
 SUPPLIER MUST INSPECT THIS DIMENSION FOR EVERY SHIPMENT.
 FAI (FAI), CPK (CPK), " (") "表示該(尺寸/位置)為設計之重點尺寸,
 供應商每次出貨前必須檢驗合格方可出貨。

5 THIS MATERIALS/PARTS/ASSEMBLIES MUST COMPLY TO ACBEL SPEC "CRITERIA FOR ENVIRONMENT-RELATED SUBSTANCES"
 零件/材料/製程皆須符合康舒"環境物質的規範"

6 CHARACTER HEIGHT : 2 MM , UNLESS OTHERWISE SPECIFIED. 圖面未標示之字體高度皆為 2毫米

7 ALL PRODUCTS MUST BE THE SAME AS ENGINEERING APPROVAL SAMPLE ANY HARD TOOLING MODIFICATION MUST BE APPROVED BY ACBEL MECHANICAL ENGINEERING SECTION
 所有產品必須與認可的樣品一致, 任何的修改都必須經由康舒機構工程師同意及認可

8 PRINTED COLOR(列印顏色) :
 BLACK(黑色) - TEXT(文字), GRAPHICS(圖形), LOGO(標誌)
 IMAGE(圖像), SURROUND SHAPE(外圍圖形)
 WHITE(白色) - BACKGROUND (背景)

9 LABEL MUST CONTAIN THE VENDOR'S ID MARK LOCATED IN THE AREA INDICATED. ID MARK LETTER HEIGHT TO BE 1.5MM
 貼紙必須印製廠商代碼, 代碼字高為 1.5毫米

10 ACBEL FACTORY CODE :
 A) ACBEL-TAIWAN: MADE IN TAIWAN ROC, NONE MARK
 B) ACBEL-DONGGUAN: MADE IN CHINA , USE "B" MARK
 C) ACBEL MANILA: MADE IN PHILIPPINES , USE "C" MARK
 康舒製造廠的標記:
 A) 康舒台灣廠: 在台灣製造的不用標記
 B) 康舒東莞廠: 在中國大陸製造的使用"B"標記
 C) 康舒馬尼拉廠: 在菲律賓製造的使用"C"標記

11 CUSTOMER ID & REV & POTION & FRU & SN BARCODE & DATAMATRIX CODE, ACBEL PRINTED CUSTOMER ID & REV , OPTION , FRU , 系列條碼、二維條碼由康舒自印

12 DATA IDENTIFIER : XXX
 FIELD TITLE : REVISION NUMBER
 FIELD LENGTH : 1 ~ 3 CHARACTERS.
 REV : XXX (FOR EXAMPLE : S1 S2 S3 00 01 ...)
 資料鑑別: XXX
 標題區: 版本號碼
 長度區: 1-3字元

17 FRU自印原則

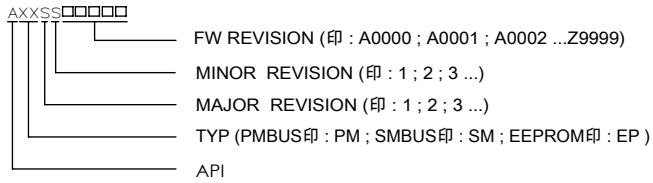

18 REV : XXX (A01印 : A01 ; A02印 : A02 ; A03印 : A03)

19 SN
 AAAYYWWSSSSSSZZZXNNNNNN

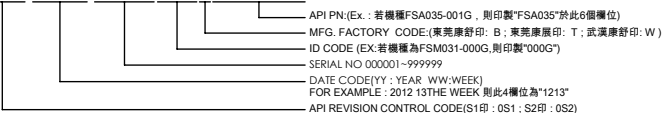

RELEASE			
正式發行圖面			REV:C
ENG.	EASON	APPR	RAY

C	UPDATE UL,TUV LOGO	20221028	EASON
B	ADD EAC, KC/KCC, Serbia, Morocco, BIS LOGO	20221014	EASON
A	RELEASE	20220117	EASON
1	PRIMARILY	20220111	EASON
REV	DESCRIPTION	DATE	BY
REVISION			

	DRAWINGS & SPEC. ARE THE EXCLUSIVE PROPERTY OF ACBEL POLYTECH INC. SAID ITEMS ARE ISSUED IN STRICT CONFIDENTIAL	MODEL NO. FSG032-00AG
		PART NO. A01AAA-8819CTC
	TOLERANCES UNLESS OTHERWISE NOTED ~6:±0.1, 6~120:±0.2, 120~315:±0.3, 315~:±0.5 ANGLES:±0.5°	DWG NO. A01AAA-8819CTC_C
		TITLE: I/O LABEL
Metric		DESIGNER EASON 2022/11/14
A4		CHECKED
SCALE : 1:1	SHEET 1 OF 2	APPROVED RAY 2022/11/14

A

A

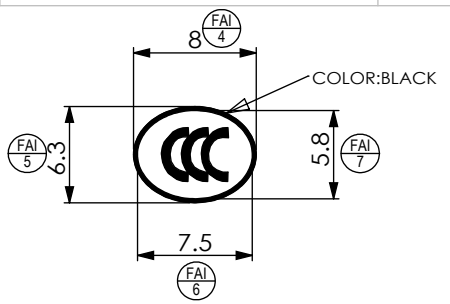
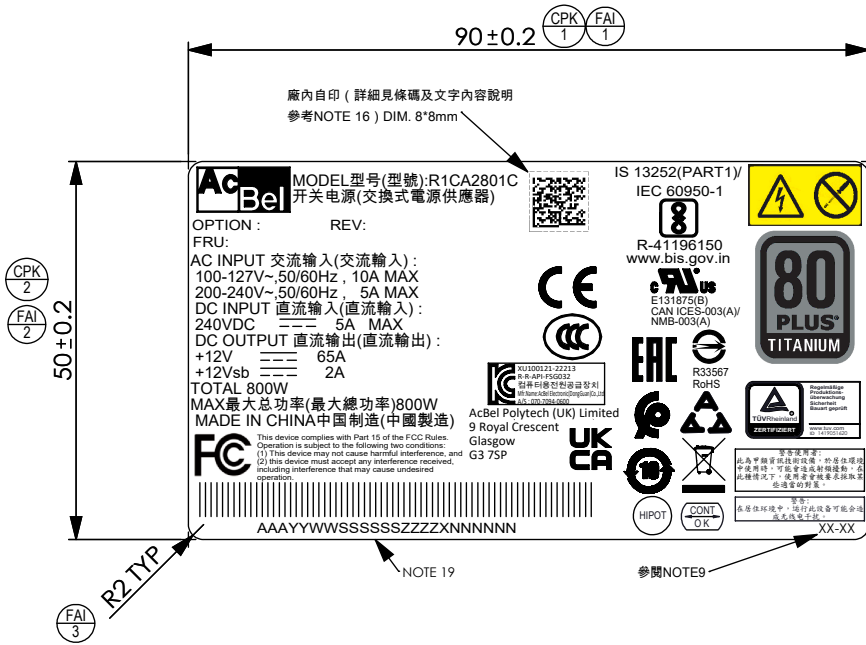

TUV LOGO DETAIL DIM.

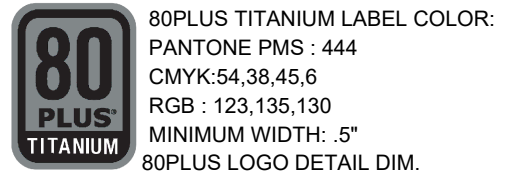

B

B

MOROCCO LOGO DETAIL
標誌垂直高度(c字母)不得小於6mm

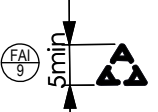

KVALITET LOGO DETAIL
文字不得小於Ariel 6號字體



BIS LOGO DETAIL

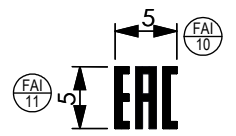

EAC LOGO DETAIL DIM.

D

D

RELEASE			
正式發行圖面			REV:C
ENG.	EASON	APPR	RAY

<p>ACBEL POLYTECH INC. STRICT CONFIDENTIAL</p>	<p>DRAWINGS & SPEC. ARE THE EXCLUSIVE PROPERTY OF ACBEL POLYTECH INC. SAID ITEMS ARE ISSUED IN STRICT CONFIDENTIAL</p> <p>TOLERANCES UNLESS OTHERWISE NOTED ~6:±0.1, 6~120:±0.2, 120~315:±0.3, 315~:±0.5 ANGLES:±0.5°</p> <p>0 mm 25</p> <p>THIRD ANGLE PROJECTION</p>	MODEL NO. FSG032-00AG
		PART NO. A01AAA-8819CTC
		DWG NO. A01AAA-8819CTC_C
		TITLE: I/O LABEL
DESIGNER	EASON	2022/11/14
CHECKED		
APPROVED	RAY	2022/11/14
SCALE: 1:1	SHEET 2 OF 2	



MODEL型号(型號):R1CA2801C
开关电源(交換式電源供應器)



IS 13252(PART1)/
IEC 60950-1



OPTION: T00A REV: A01
FRU: APM12V0005

AC INPUT 交流輸入(交流輸入):
100-127V~.50/60Hz, 10A MAX
200-240V~.50/60Hz, 5A MAX
DC INPUT 直流輸入(直流輸入):
240VDC == 5A MAX
DC OUTPUT 直流輸出(直流輸出):
+12V == 65A
+12Vsb == 2A

TOTAL 800W
MAX最大总功率(最大總功率)800W
MADE IN CHINA中国制造(中國製造)



This device complies with Part 15 of the FCC Rules.
Operation is subject to the following two conditions:
(1) This device may not cause harmful interference, and
(2) this device must accept any interference received,
including interference that may cause undesired
operation.

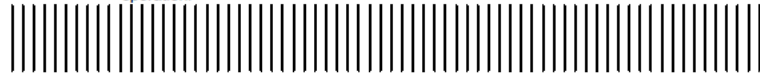

A002239R0002200AGBFSG032



AcBel Polytech (UK) Limited
9 Royal Crescent
Glasgow
G3 7SP



R-41196150
www.bis.gov.in

c **UL** us
E131875(B)
CAN ICES-003(A)/
NMB-003(A)



R33567
RoHS



警告使用者:
此為甲類資訊技術設備,於居住環境
中使用時,可能會造成射頻擾動,在
此種情況下,使用者會被要求採取某
些適當的對策。

警告:
在居住環境中,運行此設備可能會造
成無線電干擾。

XX-XX

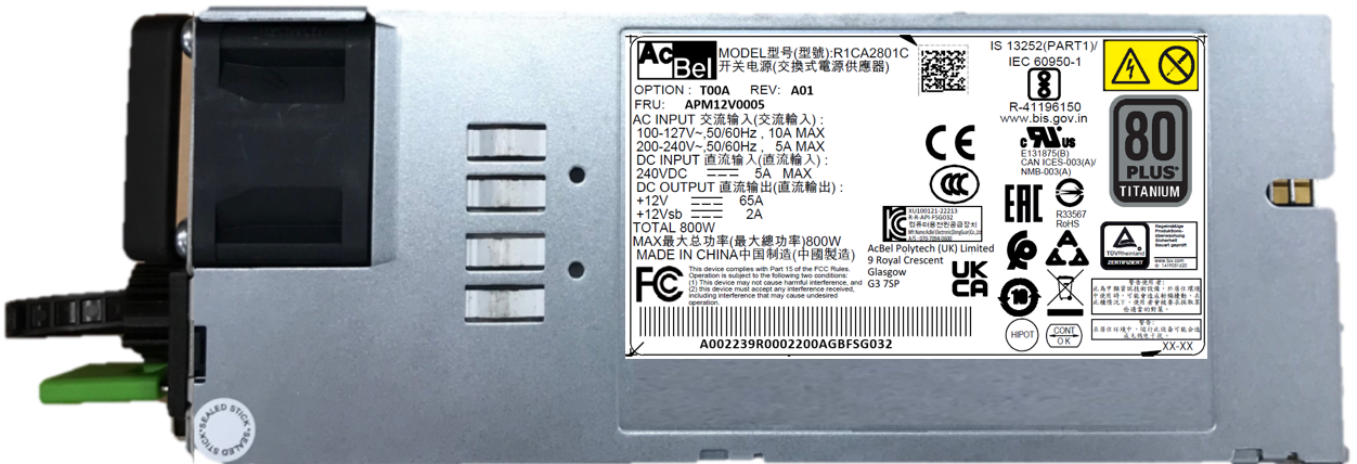



康舒科技

ACBEL POLYTECH INC.

Carton Drawing

Unit-package instruction (單體包裝說明):

- a. Don't attach the tape on PE bag's sealing place.
(塑膠袋封口不要貼膠布。)
- b. The position of desiccant is allowed to adjust.
(乾燥劑位置允許調整。)
- c. The unit drawing is for reference only.
(圖示單體僅為示意。)

Note: 1. 16 units/ carton (16台/箱)

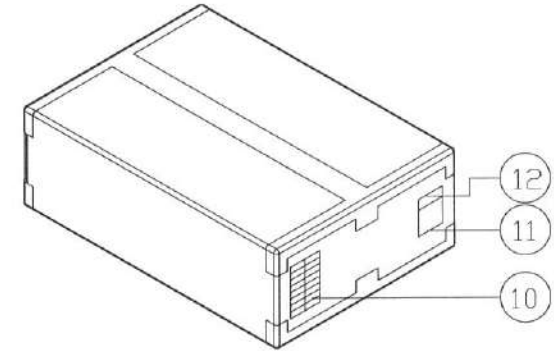

The position of serial number labels is allowed to adjust.
(序號標籤位置允許調整。)

The carton label (X01H00-2136I) should be attached before shipment.
And it is controlled by sales. (紙箱標籤 X01H00-2136I 於出貨前貼。
此紙箱標籤完全由業務控管。)

NO.	Q'TY	PART NO.	DESCRIPTION
12	1	X01H00-2136I	CARTON LABEL
11	1	X01H00-1749I	CARTON LABEL
10	16	X01H00-2035I	S/N BARCODE LABEL
9	16	X1008-E7186I	ANTISTATIC EPE BOARD
8	16	R1008-B9411I	ANTISTATIC PE BAG
7	16	FSG032-00AG	POWER SUPPLY
6	16	X1008-T9555I	DESICCATIVE
5	16	R1008-E7991IA	EPE BOARD
4	16	X1008-C1923I	KRAFT PAPER
3	2	X1008-C2543I-SA	PARTITION ASSEMBLY
2	3	X1008-C2523I	PAPER BOARD
1	1	X1008-C1958I	CARTON

		MODEL NO. FSG032-00AG
ACBEL POLYTECH INC.		PART NO. CA-FSG032-00AG_A
		DWG. NO : CA-FSG032-00AG_A
TITLE : CARTON ASS'Y FOR FSG032-00AG		
DESIGNER	SUM	1/10/22
CHECKED	Justin	1/10/22
APPROVED	Justin	1/10/22

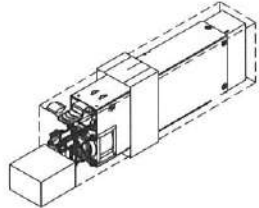
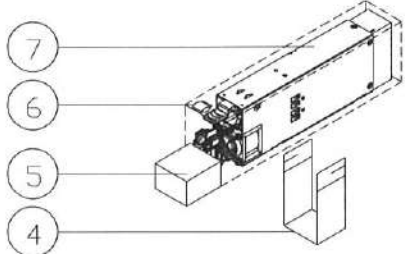
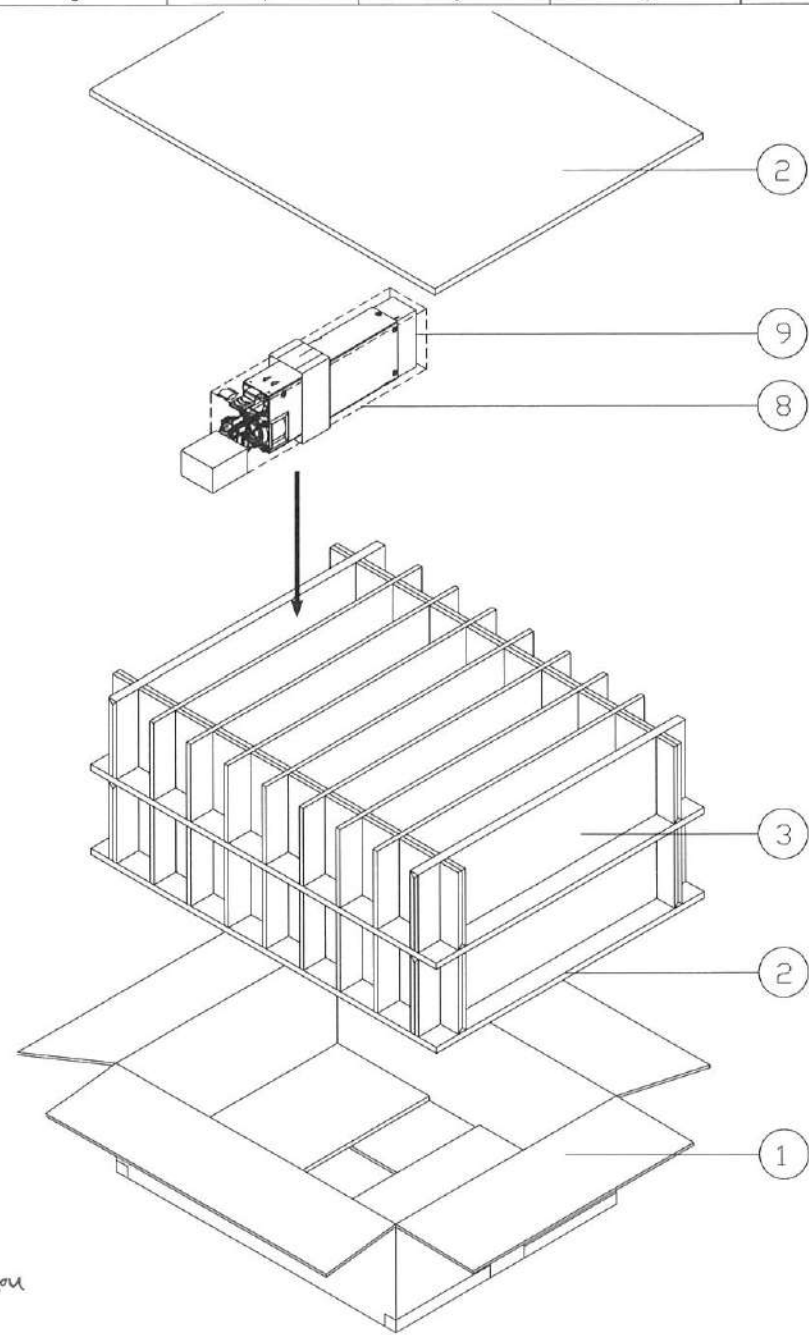

REVISIONS	DESCRIPTION	BY	DATE
REV	A	SUM	1/10/22

RELEASE
正式發行圖面 REV: A
ENG. *Sum Jian* APPR. *Justin Chou*

The requirement of labels and instructions: (標籤與說明書要求：)

- a. The carton labels are always facing outwards. (紙箱標籤一律朝外。)
- b. If there is any instruction in packaging BOM, please place it in the first carton. (如果包裝 BOM 中有說明書，請放置第一個紙箱中。)
- c. The carton label (X01H00-2136I) should be attached before shipment. And it is controlled by sales. (紙箱標籤 X01H00-2136I 於出貨前貼。此紙箱標籤完全由業務控管。)

- Notes: 1. 16 units/ carton (16台/箱)
 2. 6 cartons/ layer (6箱/層)
 3. 4 layers/ pallet (4層/棧板)
 4. 384 units/ pallet (384台/棧板)

R E L E A S E	
正式發行圖面	REV: A
ENG. <i>Sum Jian</i>	APPR. <i>Justin Chen</i>

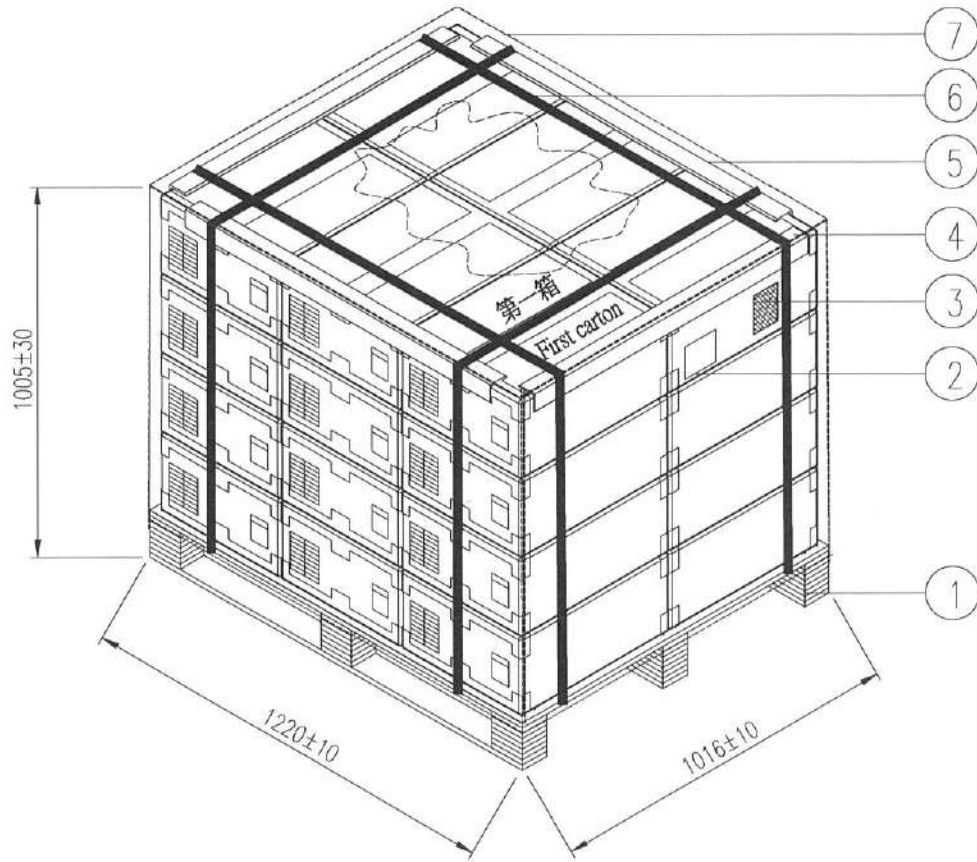

NO.	Q'TY	PART NO.	DESCRIPTION
7	50M	X1008-8064I	PE FILM
6	20M	X1008-T9998I	PET PLASTIC STRIP
5	2	X1008-C8851I	EDGE PROTECTOR
4	2	X1008-C8852I	EDGE PROTECTOR
3	2	X01C32-1198I	SHIPPING LABEL
2	2	X01G50-0012I	WARNING LABEL
1	1	X1008-P9789I	PALLET

 ACBEL POLYTECH INC.		MODEL NO. FSG032-00AG
		PART NO. PA-FSG032-00AG_A
		DWG. NO. PA-FSG032-00AG_A
 Metric A3 THIRD ANGLE PROJECTION		TITLE PALLET ASS'Y FOR FSG032-00AG
		DESIGNER SUM 1/10/22
SCALE NONE SHEET 1 OF 1		CHECKED <i>Justin</i> 1/10/22
		APPROVED <i>Justin</i> 1/10/22

REVISIONS	
REV	DATE
A	1/10/22
BY SUM	
DESCRIPTION	RELEASE



康舒科技

ACBEL POLYTECH INC.

ATE Test Report

Line Regulation									
Input Voltage (V)		Output		Limit		Test Result (V)		Pass / Fail	Remark
Vac1	Vac2	Voltage	Load(A)	Min	Max	Vout1	Vout2		
90	264	+12V	0.50	11.40	12.60	12.184	12.184	PASS	Min
		+12Vaux	0.10	11.40	12.60	12.182	12.182		
264	90	+12V	0.50	11.40	12.60	12.184	12.184	PASS	Min
		+12Vaux	0.10	11.40	12.60	12.182	12.182		
90	264	+12V	65.00	11.40	12.60	12.182	12.181	PASS	Max
		+12Vaux	2.00	11.40	12.60	12.120	12.120		
264	90	+12V	65.00	11.40	12.60	12.183	12.183	PASS	Max
		+12Vaux	2.00	11.40	12.60	12.120	12.120		

Load Regulation									
Input Voltage	Output			Limit		Test Result (V)		Pass / Fail	Remark
(Vac)	Voltage	Load1(A)	Load2(A)	Min	Max	Vout1	Vout2		
90	+12V	0.50	65.00	11.40	12.60	12.184	12.182	PASS	Min-Max
	+12Vaux	0.10	2.00	11.40	12.60	12.185	12.120		
90	+12V	65.00	0.50	11.40	12.60	12.182	12.184	PASS	Max-Min
	+12Vaux	2.00	0.10	11.40	12.60	12.120	12.185		
264	+12V	0.50	65.00	11.40	12.60	12.184	12.182	PASS	Min-Max
	+12Vaux	0.10	2.00	11.40	12.60	12.185	12.120		
264	+12V	65.00	0.50	11.40	12.60	12.182	12.184	PASS	Max-Min
	+12Vaux	2.00	0.10	11.40	12.60	12.120	12.182		

+12V Peak Load Test (2 Sec)									
Input Voltage	Output		Limit(V)		Test Result	Pass / Fail	Remarks		
(Vac)	Voltage	Load(A)	Min	Max	(V)				
90	+12V	75.00	11.40	12.60	12.18	PASS	at 2 Sec - 12V Peak		
	+12Vaux	0.10	11.40	12.60	12.22				
264	+12V	75.00	11.40	12.60	12.18	PASS	at 2 Sec - 12V Peak		
	+12Vaux	0.10	11.40	12.60	12.22				
90	+12V	75.00	*	11.00	0.00	PASS	at Over 2 Sec - 12V Peak		
	+12Vaux	0.10	11.40	12.60	12.22				
264	+12V	75.00	*	11.00	0.00	PASS	at Over 2 Sec - 12V Peak		
	+12Vaux	0.10	11.40	12.60	12.21				

Step Load Regulation									
Input Voltage	Output		Limit (V)		Test Result	Pass / Fail	Remark		
(Vac)	Voltage	Load(A)	Min	Max	(V)				
90.000	+12V	0.500	11.400	12.600	12.185	PASS	Min		
	+12Vaux	0.100	11.400	12.600	12.185				
90.000	+12V	6.500	11.400	12.600	12.204	PASS	10%		
	+12Vaux	0.200	11.400	12.600	12.203				
90.000	+12V	13.000	11.400	12.600	12.207	PASS	20%		
	+12Vaux	0.400	11.400	12.600	12.198				
90.000	+12V	19.500	11.400	12.600	12.204	PASS	30%		
	+12Vaux	0.600	11.400	12.600	12.188				
90.000	+12V	26.000	11.400	12.600	12.200	PASS	40%		
	+12Vaux	0.800	11.400	12.600	12.177				
90.000	+12V	32.500	11.400	12.600	12.197	PASS	50%		
	+12Vaux	1.000	11.400	12.600	12.167				

90.000	+12V	39.000	11.400	12.600	12.193	PASS	60%
	+12Vaux	1.200	11.400	12.600	12.158		
90.000	+12V	45.500	11.400	12.600	12.189	PASS	70%
	+12Vaux	1.400	11.400	12.600	12.148		
90.000	+12V	52.000	11.400	12.600	12.186	PASS	80%
	+12Vaux	1.600	11.400	12.600	12.137		
90.000	+12V	58.500	11.400	12.600	12.183	PASS	90%
	+12Vaux	1.800	11.400	12.600	12.127		
90.000	+12V	65.000	11.400	12.600	12.182	PASS	Max
	+12Vaux	2.000	11.400	12.600	12.120		
264.000	+12V	0.500	11.400	12.600	12.184	PASS	Min
	+12Vaux	0.100	11.400	12.600	12.182		
264.000	+12V	6.500	11.400	12.600	12.203	PASS	10%
	+12Vaux	0.200	11.400	12.600	12.200		
264.000	+12V	13.000	11.400	12.600	12.207	PASS	20%
	+12Vaux	0.400	11.400	12.600	12.198		
264.000	+12V	19.500	11.400	12.600	12.203	PASS	30%
	+12Vaux	0.600	11.400	12.600	12.188		
264.000	+12V	26.000	11.400	12.600	12.200	PASS	40%
	+12Vaux	0.800	11.400	12.600	12.177		
264.000	+12V	32.500	11.400	12.600	12.196	PASS	50%
	+12Vaux	1.000	11.400	12.600	12.167		
264.000	+12V	39.000	11.400	12.600	12.192	PASS	60%
	+12Vaux	1.200	11.400	12.600	12.158		
264.000	+12V	45.500	11.400	12.600	12.189	PASS	70%
	+12Vaux	1.400	11.400	12.600	12.148		
264.000	+12V	52.000	11.400	12.600	12.186	PASS	80%
	+12Vaux	1.600	11.400	12.600	12.137		
264.000	+12V	58.500	11.400	12.600	12.183	PASS	90%
	+12Vaux	1.800	11.400	12.600	12.127		
264.000	+12V	65.000	11.400	12.600	12.181	PASS	Max
	+12Vaux	2.000	11.400	12.600	12.120		

Ishare Voltage							
Input voltage (Vac)	Output		Limit (V)		Tes Result (V)	Pass/Fail	Remark
	Voltage	Load	Min	Max			
90.000	+12V	0.000	*	0.300	0.028	PASS	0%
	+12Vaux	0.000					
90.000	+12V	13.000	1.400	1.800	1.597	PASS	20%
	+12Vaux	0.400					
90.000	+12V	32.500	3.800	4.200	4.079	PASS	50%
	+12Vaux	1.000					
90.000	+12V	65.000	7.800	8.200	8.190	PASS	100%
	+12Vaux	2.000					
264.000	+12V	0.000	*	0.300	0.029	PASS	0%
	+12Vaux	0.000					
264.000	+12V	13.000	1.400	1.800	1.599	PASS	20%
	+12Vaux	0.400					
264.000	+12V	32.500	3.800	4.200	4.080	PASS	50%
	+12Vaux	1.000					
264.000	+12V	65.000	7.800	8.200	8.191	PASS	100%
	+12Vaux	2.000					

+12V Peak Current Protection							
Input Voltage	Output	Duration Time	Limit (V)	Test Result	Pass/Fail	Remark	

Voltage				Eff (%)	PF	iTHD (%)						/	
(Vac)	(Hz)	Voltage	Load(A)	Min	Min	Max	Efficiency (%)	Power Factor	iTHD (%)	Input Current(A)	Input Power(W)		
230	50	+12V	6.500	90.000	0.900	20.000	91.158	0.963	11.188	0.404	89.589	PASS	10%
		+12Vaux	0.200										
230	50	+12V	13.000	*	0.960	10.000	94.395	0.990	8.370	0.760	173.310	PASS	20%
		+12Vaux	0.400										
230	50	+12V	19.500	94.000	*	*	95.248	0.993	7.457	1.125	257.470	PASS	30%
		+12Vaux	0.600										
230	50	+12V	26.000	94.000	*	*	95.576	0.997	6.455	1.489	341.950	PASS	40%
		+12Vaux	0.800										
230	50	+12V	32.500	95.000	0.980	8.000	95.567	0.998	6.212	1.860	427.490	PASS	50%
		+12Vaux	1.000										
230	50	+12V	39.000	94.000	*	*	95.093	0.992	6.204	2.255	515.310	PASS	60%
		+12Vaux	1.200										
230	50	+12V	45.500	94.000	*	*	94.921	0.987	5.378	2.647	602.030	PASS	70%
		+12Vaux	1.400										
230	50	+12V	52.000	94.000	*	*	94.645	0.991	4.285	3.024	689.950	PASS	80%
		+12Vaux	1.600										
230	50	+12V	58.500	*	*	*	94.362	0.993	4.100	3.404	778.250	PASS	90%
		+12Vaux	1.800										
230	50	+12V	65.000	91.000	0.990	5.000	93.892	0.994	4.021	3.793	868.760	PASS	100%
		+12Vaux	2.000										
115	60	+12V	6.500	*	0.900	20.000	89.241	0.987	10.085	0.804	91.515	PASS	10%
		+12Vaux	0.200										
115	60	+12V	13.000	*	0.960	10.000	92.359	0.992	9.760	1.548	177.130	PASS	20%
		+12Vaux	0.400										
115	60	+12V	19.500	*	*	*	93.374	0.993	5.530	2.292	262.650	PASS	30%
		+12Vaux	0.600										
115	60	+12V	26.000	*	*	*	93.809	0.997	4.975	3.027	348.410	PASS	40%
		+12Vaux	0.800										
115	60	+12V	32.500	*	0.980	8.000	93.692	0.993	4.760	3.805	436.090	PASS	50%
		+12Vaux	1.000										
115	60	+12V	39.000	*	*	*	93.446	0.996	4.129	4.564	524.430	PASS	60%
		+12Vaux	1.200										
115	60	+12V	45.500	*	*	*	93.029	0.997	3.264	5.339	614.310	PASS	70%
		+12Vaux	1.400										
115	60	+12V	52.000	*	*	*	92.516	0.998	3.077	6.131	705.930	PASS	80%
		+12Vaux	1.600										
115	60	+12V	58.500	*	*	*	91.925	0.999	2.595	6.933	798.960	PASS	90%
		+12Vaux	1.800										
115	60	+12V	65.000	*	0.990	5.000	91.262	0.999	2.438	7.756	893.970	PASS	100%
		+12Vaux	2.000										

Brown Up											
Input Voltage (Vac)		Output		Limit		Test Result	Output Voltage (V)		Pass / Fail	Remarks	
Start	End	Voltage	Load(A)	Min	Max	(Vac)	Start	End			
65	90	+12V	0.50	81.00	89.00	86.26	0.00	12.18	PASS	Min_Load	
		+12Vaux	0.10				0.00	12.18			
65	90	+12V	65.00	81.00	89.00	85.66	0.00	12.18	PASS	Max_Load	
		+12Vaux	2.00				0.00	12.12			

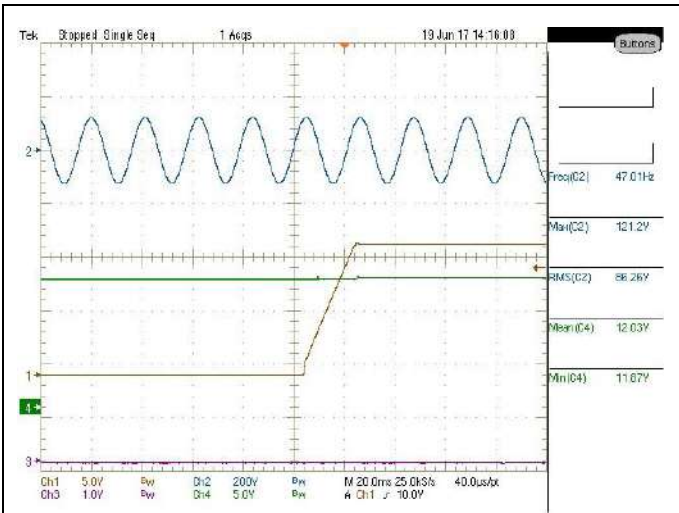

Min_Load

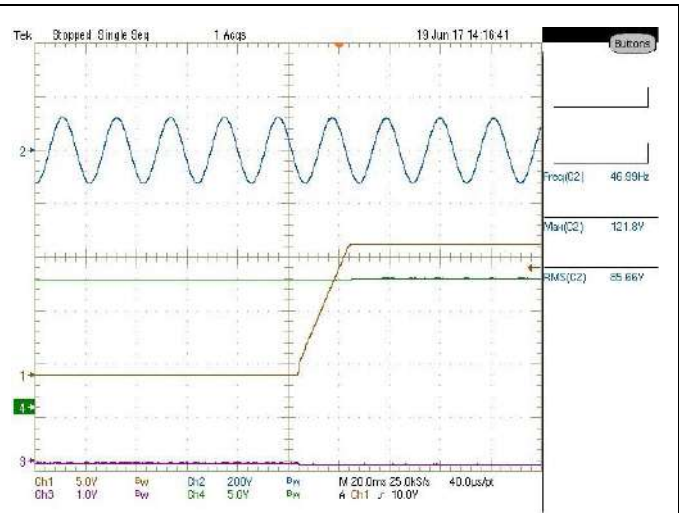

Max_Load

Brown Out										
Input Voltage (Vac)		Output		Limit		Test Result	Output Voltage (V)		Pass / Fail	Remarks
Start	End	Voltage	Load(A)	Min	Max	(Vac)	Start	End		
90	60	+12V	0.50	70.00	80.00	74.86	12.18	0.00	PASS	Min_Load
		+12Vaux	0.10				12.19	12.06		
90	60	+12V	65.00	70.00	80.00	79.19	2.39	0.00	PASS	Max_Load
		+12Vaux	2.00				12.12	11.91		

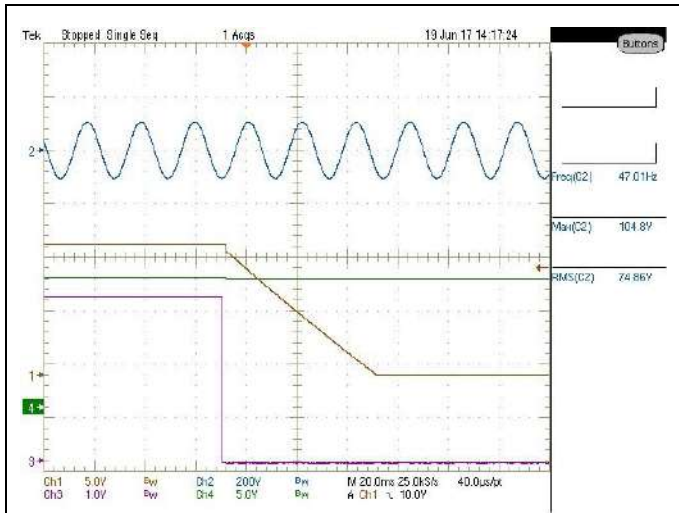

Min_Load

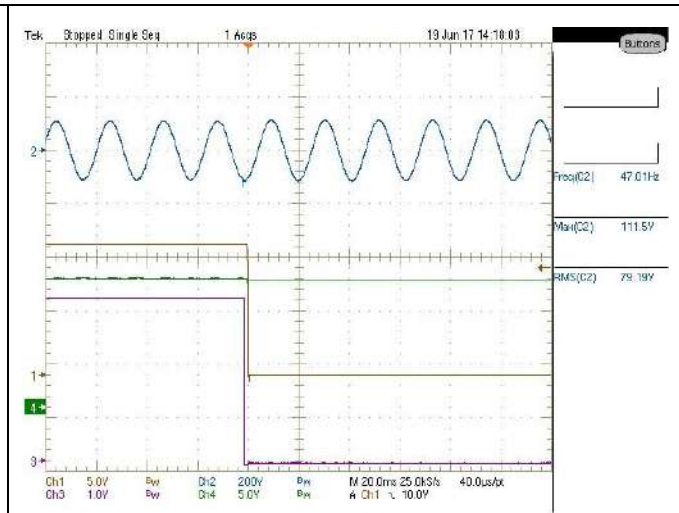

Max_Load

12V Dynamic (50Hz, 2:18 ms)									
Input Voltage (Vac)	Output			Limit		Test Result		Pass / Fail	Remark
	Voltage	Load		Min	Max	Vpk min	Vpk max		
90	+12V	32.50	1.00	11.40	12.60	12.018	12.462	PASS	Fig : 1 (18:2ms)
	+12Vaux	0.10	0.10						
90	+12V	32.50	1.00	11.40	12.60	11.907	12.462	PASS	Fig : 2

	+12Vaux	2.00	2.00						(18:2ms)
90	+12V	32.50	65.00	11.40	12.60	11.954	12.489	PASS	Fig : 3 (18:2ms)
	+12Vaux	0.10	0.10						
90	+12V	32.50	65.00	11.40	12.60	11.955	12.492	PASS	Fig : 4 (18:2ms)
	+12Vaux	2.00	2.00						
264	+12V	32.50	1.00	11.40	12.60	11.585	12.450	PASS	Fig : 5 (18:2ms)
	+12Vaux	0.10	0.10						
264	+12V	32.50	1.00	11.40	12.60	11.809	12.468	PASS	Fig : 6 (18:2ms)
	+12Vaux	2.00	2.00						
264	+12V	32.50	65.00	11.40	12.60	11.955	12.492	PASS	Fig : 7 (18:2ms)
	+12Vaux	0.10	0.10						
264	+12V	32.50	65.00	11.40	12.60	11.954	12.494	PASS	Fig : 8 (18:2ms)
	+12Vaux	2.00	2.00						
90	+12V	32.50	1.00	11.40	12.60	12.019	12.463	PASS	Fig : 9 (2:18ms)
	+12Vaux	0.10	0.10						
90	+12V	32.50	1.00	11.40	12.60	12.019	12.467	PASS	Fig : 10 (2:18ms)
	+12Vaux	2.00	2.00						
90	+12V	32.50	65.00	11.40	12.60	11.950	12.482	PASS	Fig : 11 (2:18ms)
	+12Vaux	0.10	0.10						
90	+12V	32.50	65.00	11.40	12.60	11.949	12.483	PASS	Fig : 12 (2:18ms)
	+12Vaux	2.00	2.00						
264	+12V	32.50	1.00	11.40	12.60	12.021	12.464	PASS	Fig : 13 (2:18ms)
	+12Vaux	0.10	0.10						
264	+12V	32.50	1.00	11.40	12.60	12.021	12.470	PASS	Fig : 14 (2:18ms)
	+12Vaux	2.00	2.00						
264	+12V	32.50	65.00	11.40	12.60	11.950	12.483	PASS	Fig : 15 (2:18ms)
	+12Vaux	0.10	0.10						
264	+12V	32.50	65.00	11.40	12.60	11.948	12.484	PASS	Fig : 16 (2:18ms)
	+12Vaux	2.00	2.00						

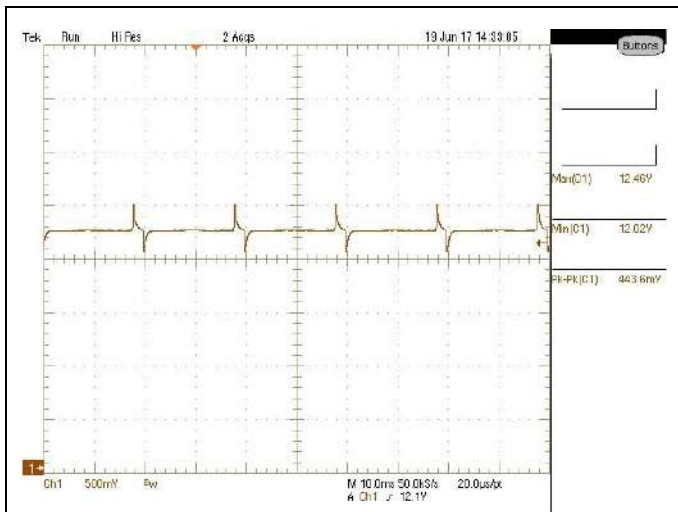

Fig : 1 (18:2ms)

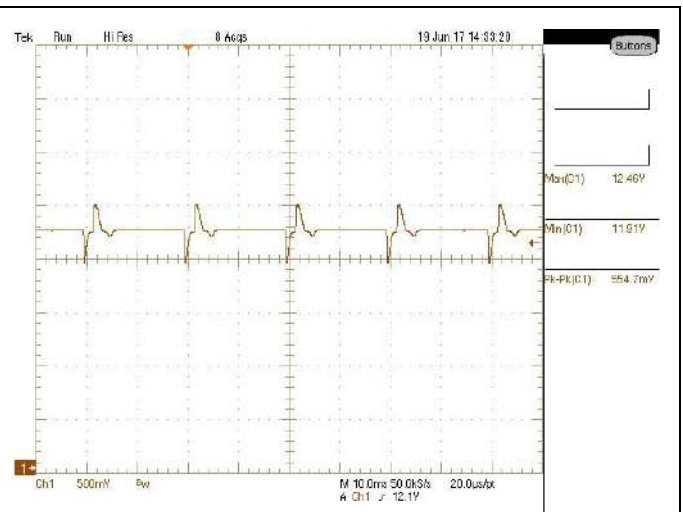

Fig : 2 (18:2ms)

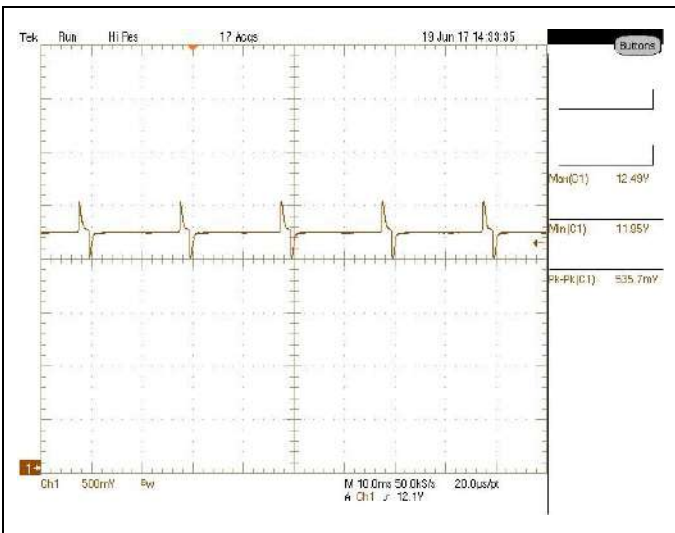

Fig : 3 (18:2ms)

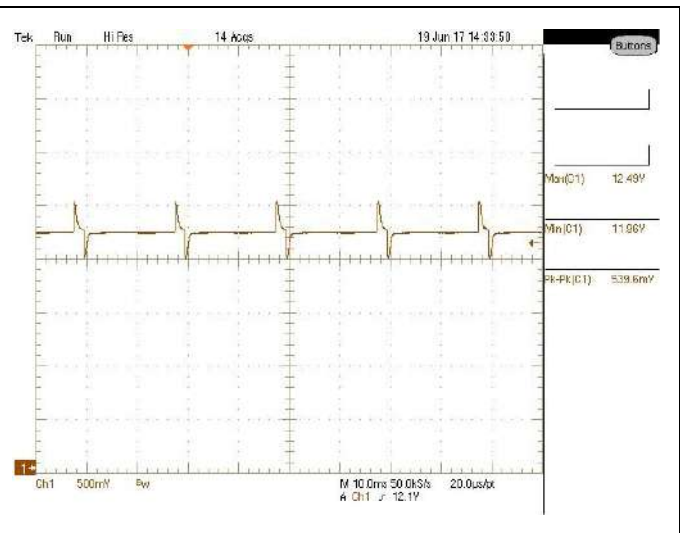

Fig : 4 (18:2ms)

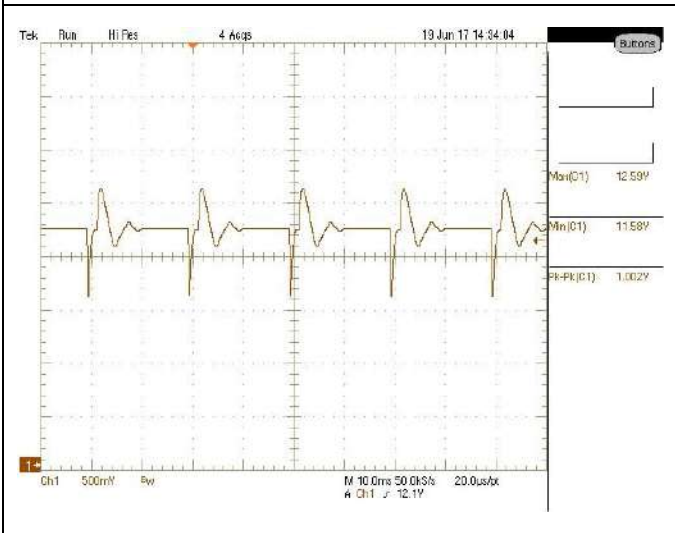

Fig : 5 (18:2ms)

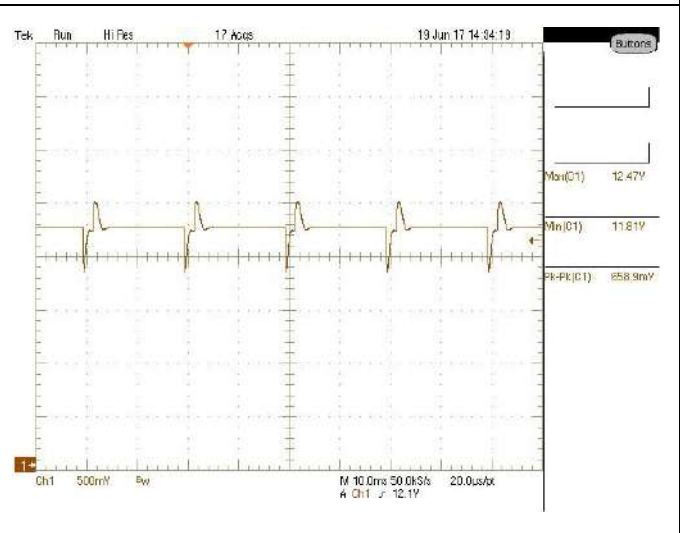

Fig : 6 (18:2ms)

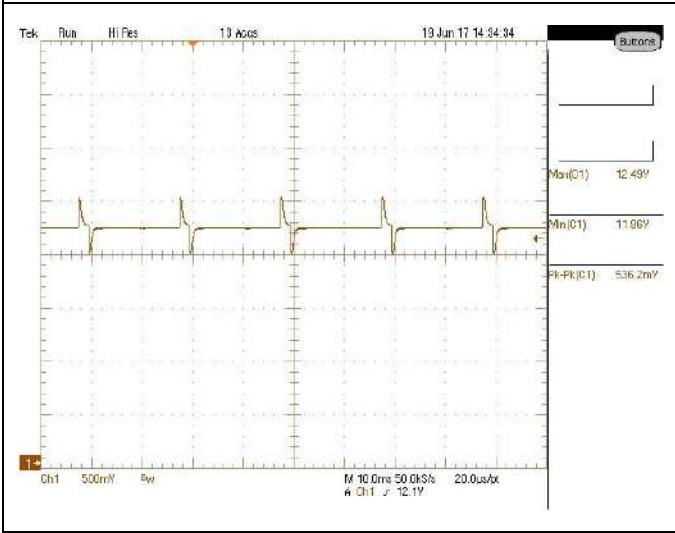

Fig : 7 (18:2ms)

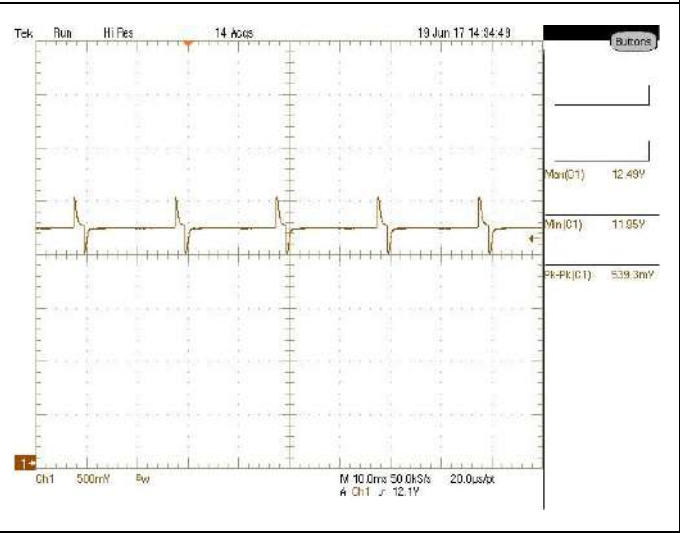

Fig : 8 (18:2ms)

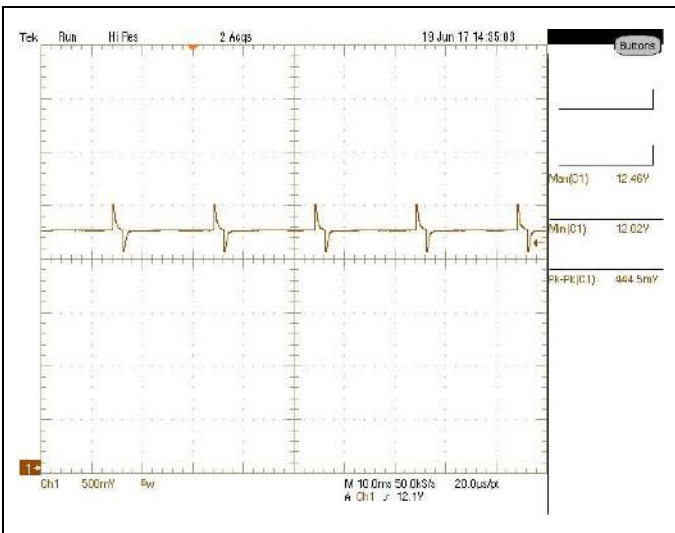

Fig : 9 (2:18ms)

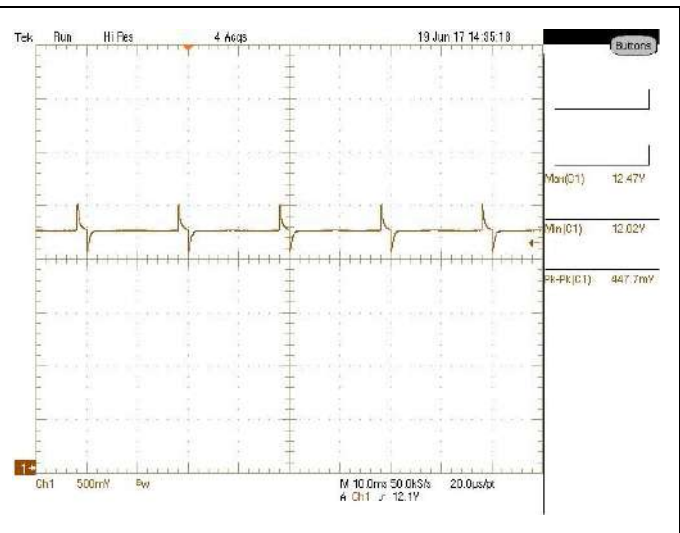

Fig : 10 (2:18ms)

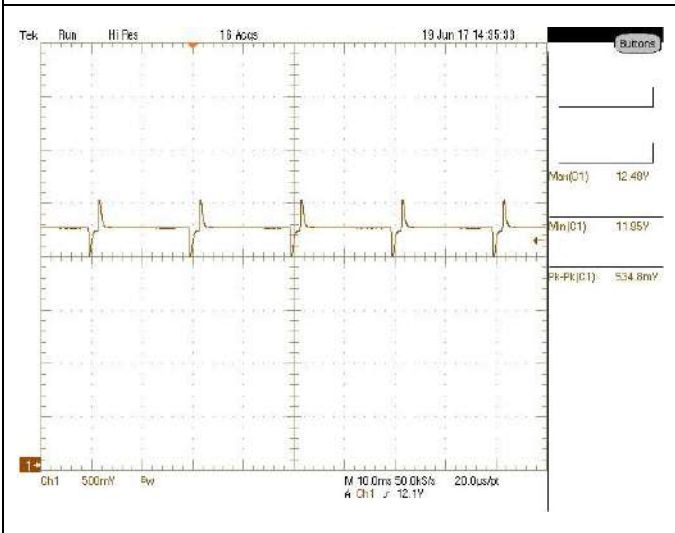

Fig : 11 (2:18ms)

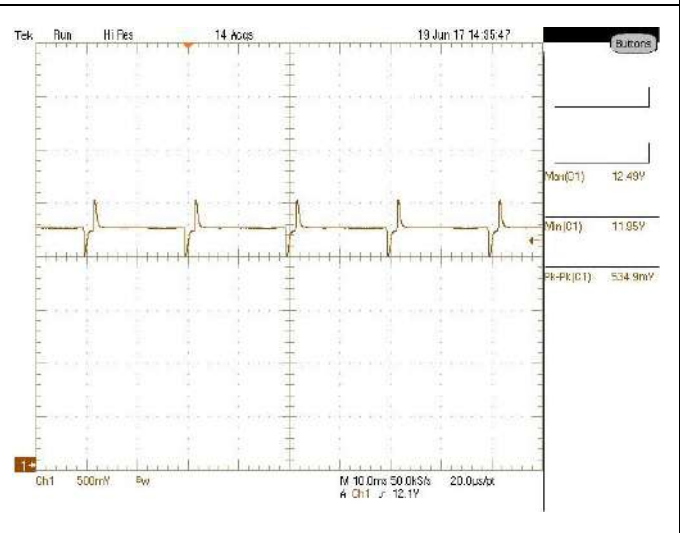

Fig : 12 (2:18ms)

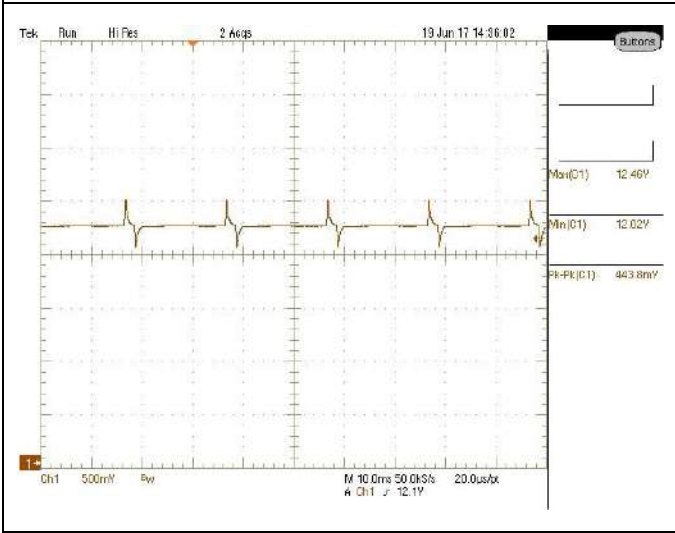

Fig : 13 (2:18ms)

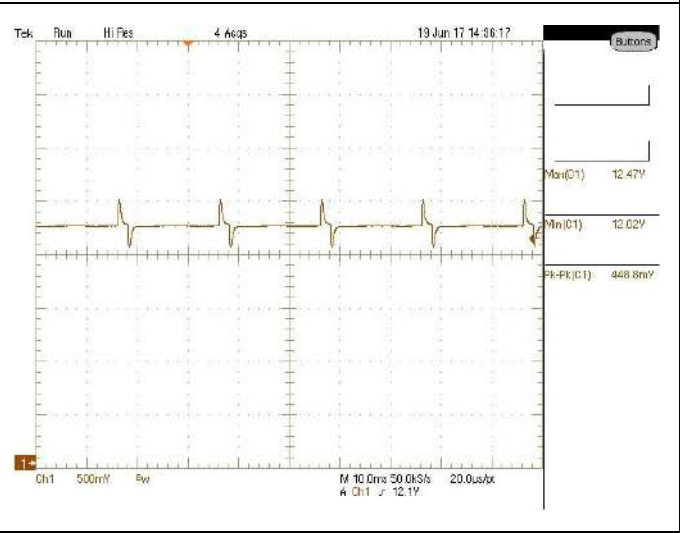

Fig : 14 (2:18ms)

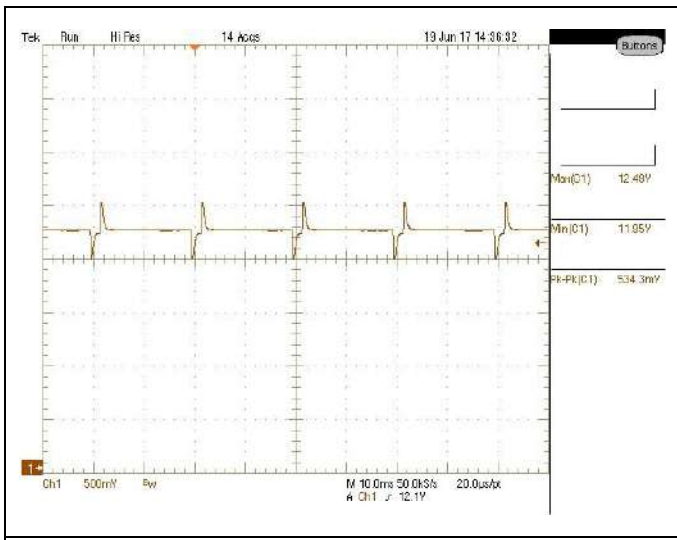

Fig : 15 (2:18ms)

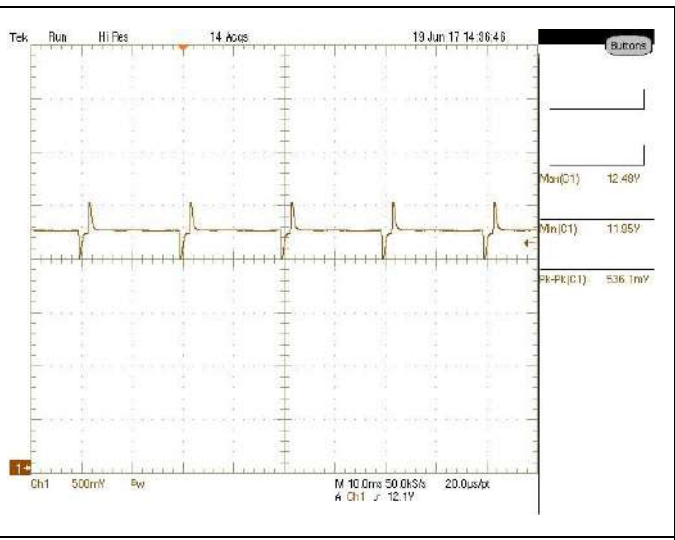

Fig : 16 (2:18ms)

12V Dynamic (10KHz, 0.025:0.075 mS)									
Input Voltage	Output			Limit		Test Result		Pass / Fail	Remark
	Voltage	Load		Min	Max	Vpk min	Vpk max		
(Vac)		Load1(A)	Load2(A)						
90	+12V	32.500	1.000	11.400	12.600	12.203	12.262	PASS	Fig : 1 (0.075:0.025ms)
	+12Vaux	0.100	0.100						
90	+12V	32.500	1.000	11.400	12.600	12.201	12.275	PASS	Fig : 2 (0.075:0.025ms)
	+12Vaux	2.000	2.000						
90	+12V	32.500	65.000	11.400	12.600	12.184	12.275	PASS	Fig : 3 (0.075:0.025ms)
	+12Vaux	0.100	0.100						
90	+12V	32.500	65.000	11.400	12.600	12.181	12.264	PASS	Fig : 4 (0.075:0.025ms)
	+12Vaux	2.000	2.000						
264	+12V	32.500	1.000	11.400	12.600	12.202	12.260	PASS	Fig : 5 (0.075:0.025ms)
	+12Vaux	0.100	0.100						
264	+12V	32.500	1.000	11.400	12.600	12.196	12.260	PASS	Fig : 6 (0.075:0.025ms)
	+12Vaux	2.000	2.000						
264	+12V	32.500	65.000	11.400	12.600	12.182	12.262	PASS	Fig : 7 (0.075:0.025ms)
	+12Vaux	0.100	0.100						
264	+12V	32.500	65.000	11.400	12.600	12.174	12.259	PASS	Fig : 8 (0.075:0.025ms)
	+12Vaux	2.000	2.000						
90	+12V	32.500	1.000	11.400	12.600	12.200	12.274	PASS	Fig : 9 (0.025:0.075ms)
	+12Vaux	0.100	0.100						
90	+12V	32.500	1.000	11.400	12.600	12.199	12.274	PASS	Fig : 10 (0.025:0.075ms)
	+12Vaux	2.000	2.000						
90	+12V	32.500	65.000	11.400	12.600	12.191	12.272	PASS	Fig : 11 (0.025:0.075ms)
	+12Vaux	0.100	0.100						
90	+12V	32.500	65.000	11.400	12.600	12.189	12.266	PASS	Fig : 12 (0.025:0.075ms)
	+12Vaux	2.000	2.000						
264	+12V	32.500	1.000	11.400	12.600	12.204	12.277	PASS	Fig : 13 (0.025:0.075ms)
	+12Vaux	0.100	0.100						
264	+12V	32.500	1.000	11.400	12.600	12.200	12.274	PASS	Fig : 14 (0.025:0.075ms)
	+12Vaux	2.000	2.000						
264	+12V	32.500	65.000	11.400	12.600	12.187	12.265	PASS	Fig : 15 (0.025:0.075ms)
	+12Vaux	0.100	0.100						
264	+12V	32.500	65.000	11.400	12.600	12.189	12.267	PASS	Fig : 16 (0.025:0.075ms)
	+12Vaux	2.000	2.000						

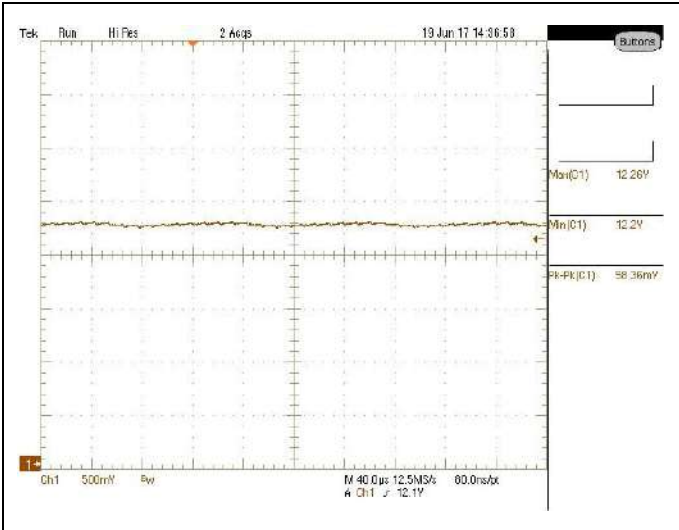

Fig : 1 (0.075:0.025ms)

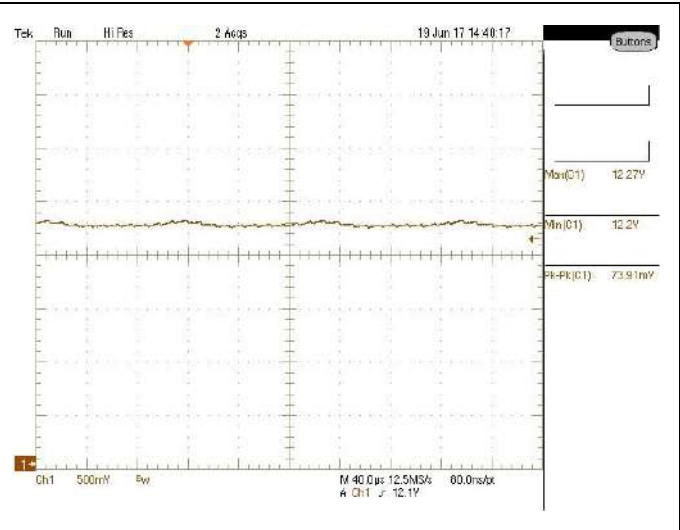

Fig : 2 (0.075:0.025ms)

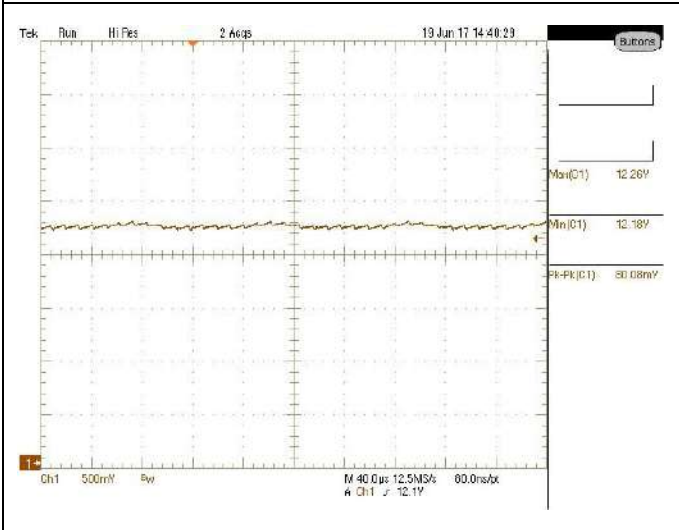

Fig : 3 (0.075:0.025ms)

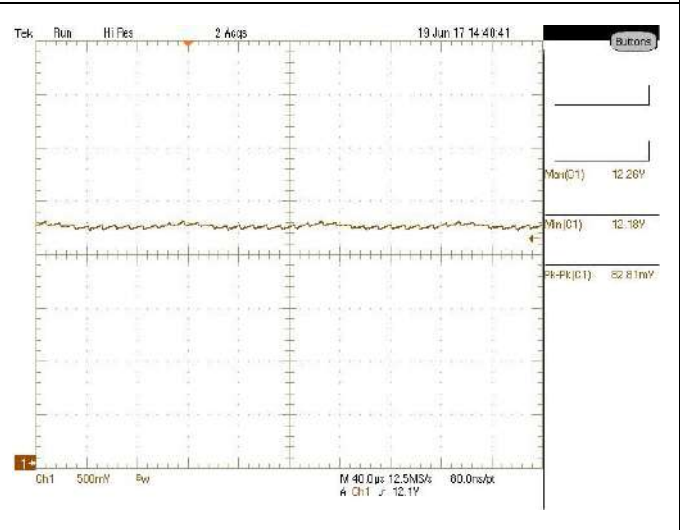

Fig : 4 (0.075:0.025ms)

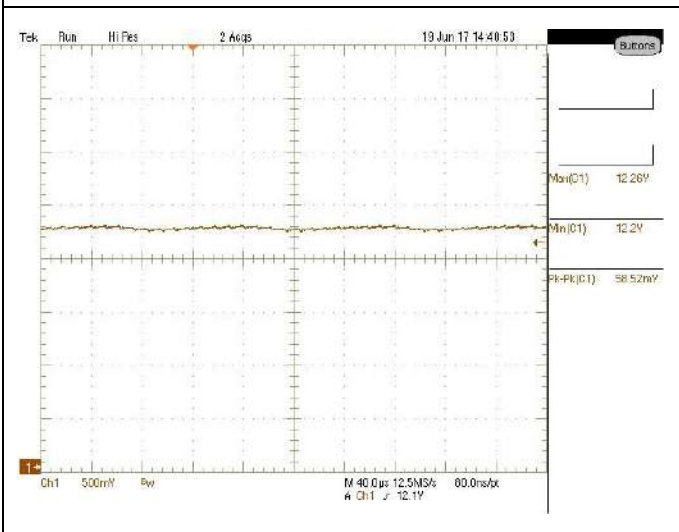

Fig : 5 (0.075:0.025ms)

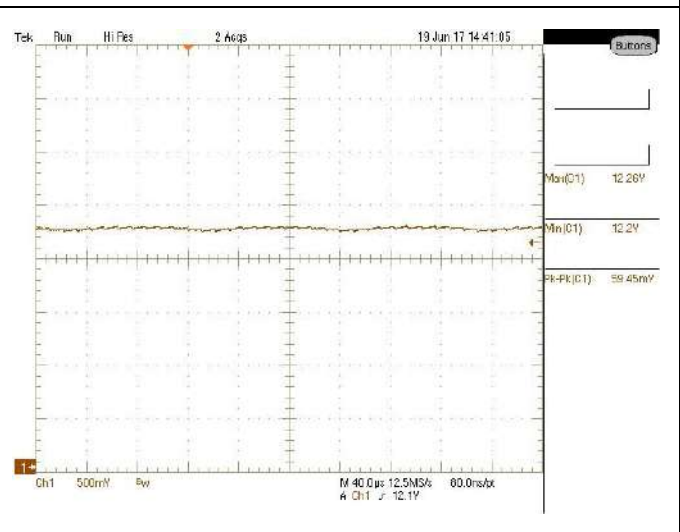

Fig : 6 (0.075:0.025ms)

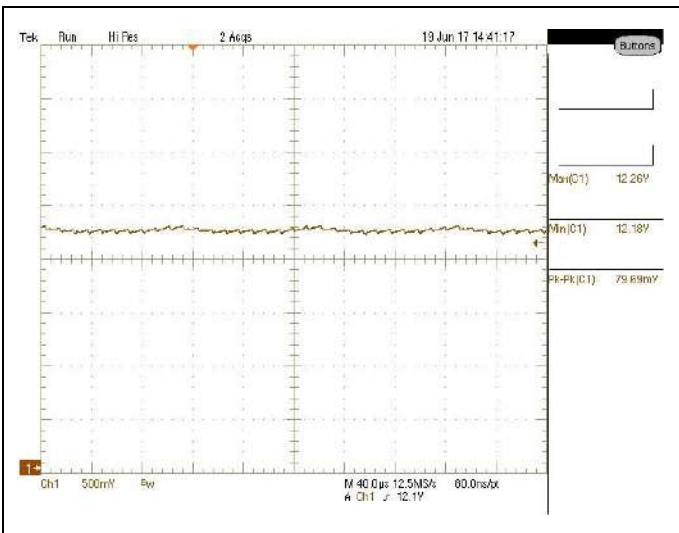

Fig : 7 (0.075:0.025ms)

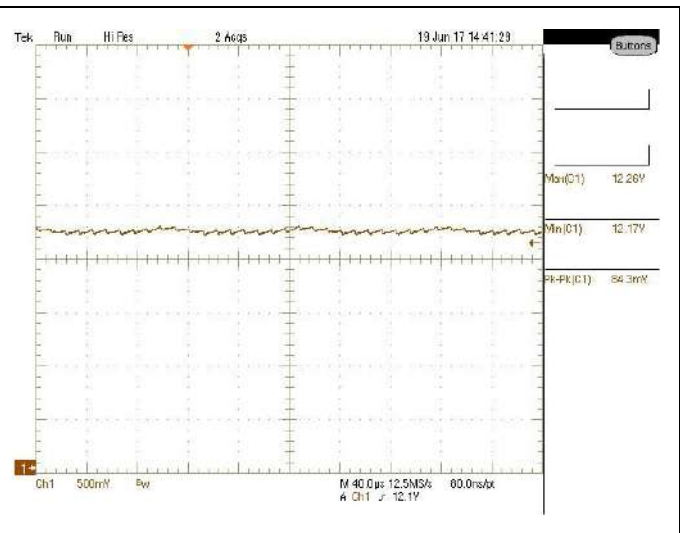

Fig : 8 (0.075:0.025ms)

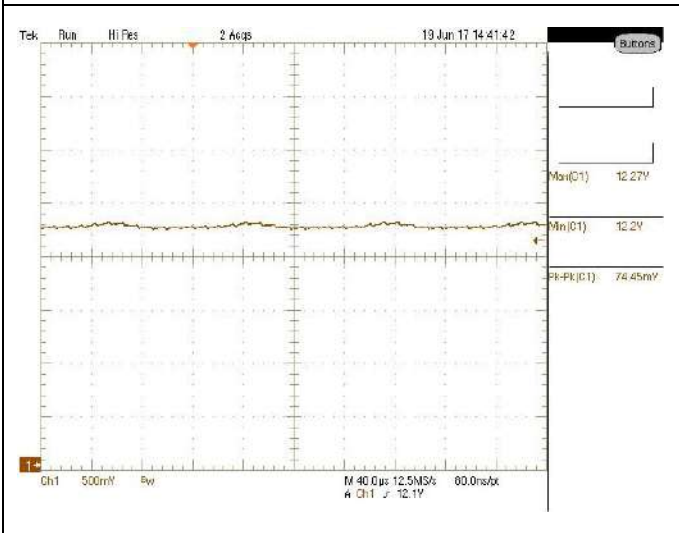

Fig : 9 (0.025:0.075ms)

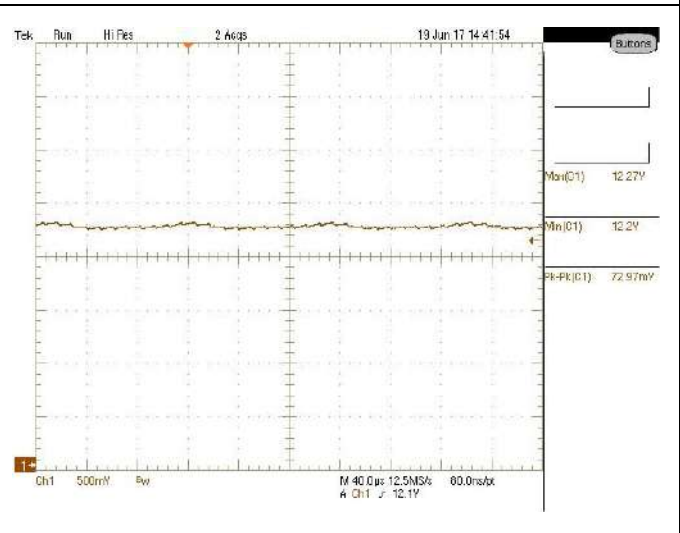

Fig : 10 (0.025:0.075ms)

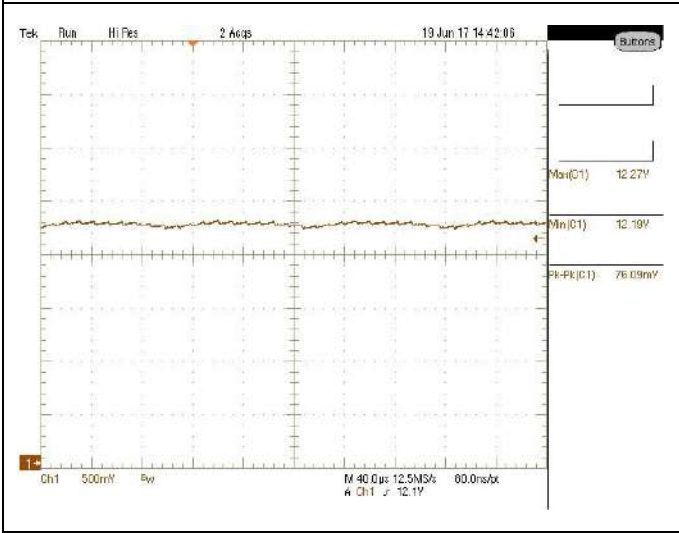

Fig : 11 (0.025:0.075ms)

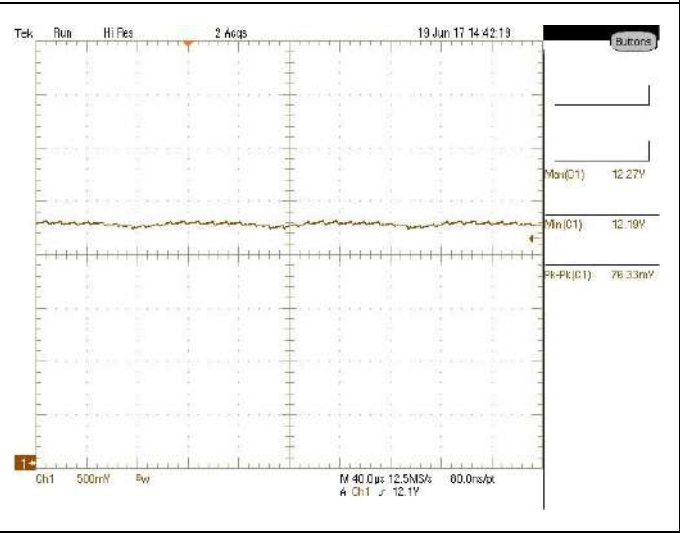

Fig : 12 (0.025:0.075ms)

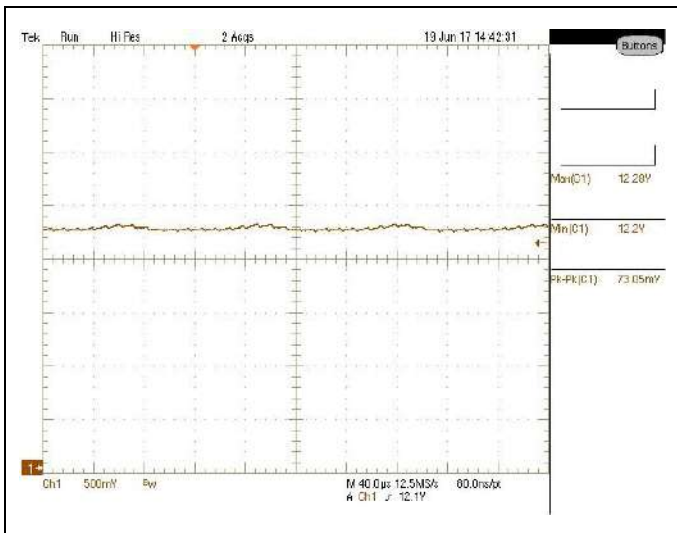

Fig : 13 (0.025:0.075ms)

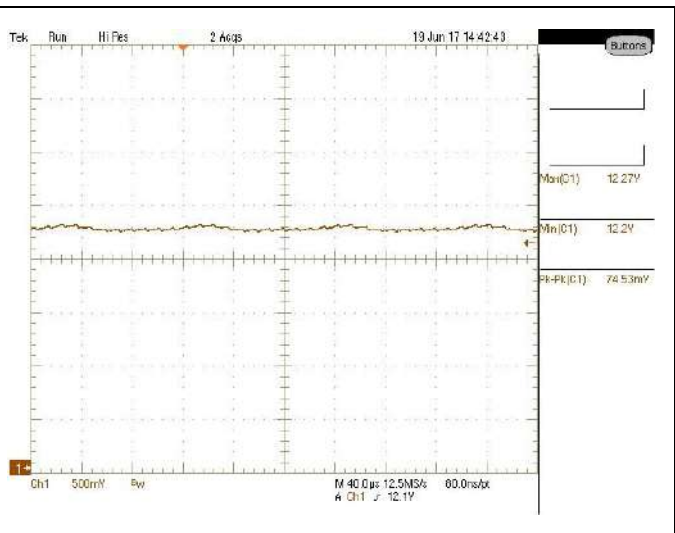

Fig : 14 (0.025:0.075ms)

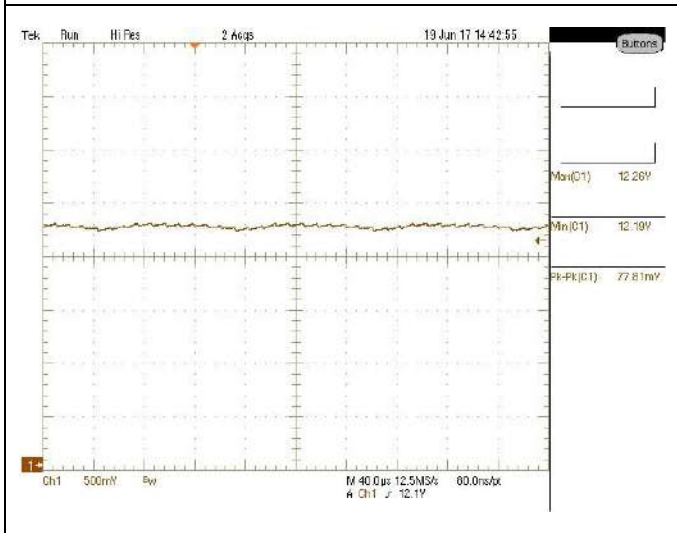

Fig : 15 (0.025:0.075ms)

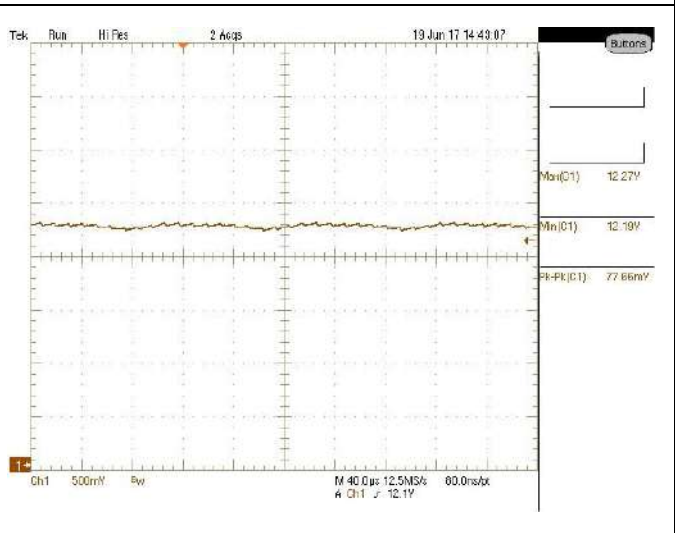

Fig : 16 (0.025:0.075ms)

12Vsb Dynamic (50Hz, 2:18 mS)									
Input Voltage (Vac)	Voltage	Output Load		Limit		Test Result		Pass / Fail	Remark
		Load1(A)	Load2(A)	Min	Max	Vpk min	Vpk max		
90	+12V	0.500	0.500	11.400	12.600	12.060	12.320	PASS	Fig : 1 (18:2ms)
	+12Vaux	1.000	0.000						
90	+12V	65.000	65.000	11.400	12.600	12.162	12.231	PASS	Fig : 2 (18:2ms)
	+12Vaux	1.000	0.000						
90	+12V	0.500	0.500	11.400	12.600	12.005	12.230	PASS	Fig : 3 (18:2ms)
	+12Vaux	1.000	2.000						
90	+12V	65.000	65.000	11.400	12.600	12.112	12.182	PASS	Fig : 4 (18:2ms)
	+12Vaux	1.000	2.000						
264	+12V	0.500	0.500	11.400	12.600	12.058	12.318	PASS	Fig : 5 (18:2ms)
	+12Vaux	1.000	0.000						
264	+12V	65.000	65.000	11.400	12.600	12.158	12.227	PASS	Fig : 6 (18:2ms)
	+12Vaux	1.000	0.000						
264	+12V	0.500	0.500	11.400	12.600	11.993	12.238	PASS	Fig : 7 (18:2ms)
	+12Vaux	1.000	2.000						

264	+12V	65.000	65.000	11.400	12.600	12.112	12.180	PASS	Fig : 8 (18:2ms)
	+12Vaux	1.000	2.000						
90	+12V	0.500	0.500	11.400	12.600	12.010	12.312	PASS	Fig : 9 (2:18ms)
	+12Vaux	1.000	0.000						
90	+12V	65.000	65.000	11.400	12.600	12.156	12.228	PASS	Fig : 10 (2:18ms)
	+12Vaux	1.000	0.000						
90	+12V	0.500	0.500	11.400	12.600	12.017	12.231	PASS	Fig : 11 (2:18ms)
	+12Vaux	1.000	2.000						
90	+12V	65.000	65.000	11.400	12.600	12.111	12.181	PASS	Fig : 12 (2:18ms)
	+12Vaux	1.000	2.000						
264	+12V	0.500	0.500	11.400	12.600	12.006	12.317	PASS	Fig : 13 (2:18ms)
	+12Vaux	1.000	0.000						
264	+12V	65.000	65.000	11.400	12.600	12.155	12.228	PASS	Fig : 14 (2:18ms)
	+12Vaux	1.000	0.000						
264	+12V	0.500	0.500	11.400	12.600	11.993	12.240	PASS	Fig : 15 (2:18ms)
	+12Vaux	1.000	2.000						
264	+12V	65.000	65.000	11.400	12.600	12.112	12.183	PASS	Fig : 16 (2:18ms)
	+12Vaux	1.000	2.000						

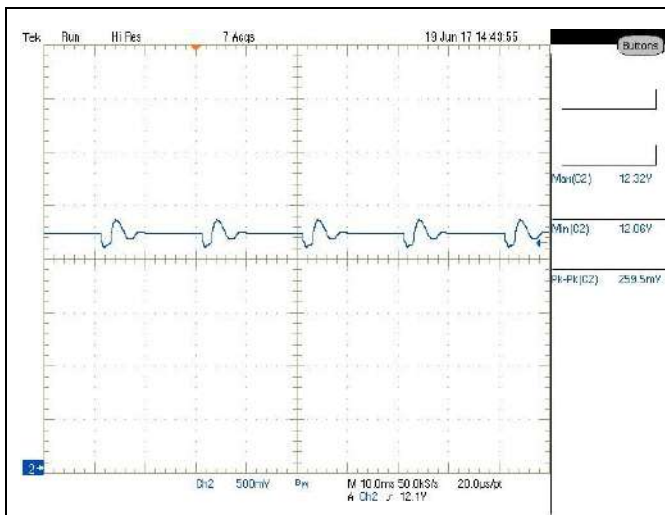

Fig : 1 (18:2ms)

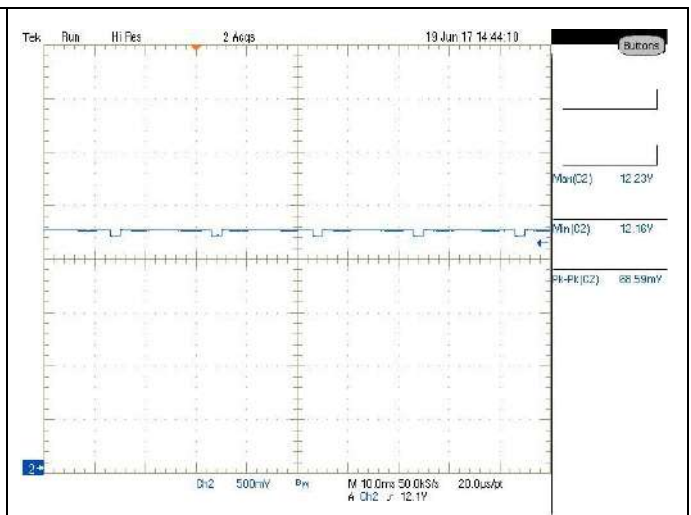

Fig : 2 (18:2ms)

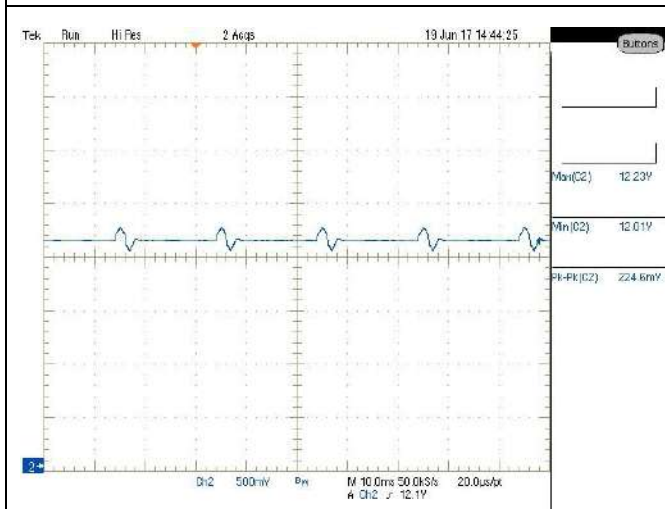

Fig : 3 (18:2ms)

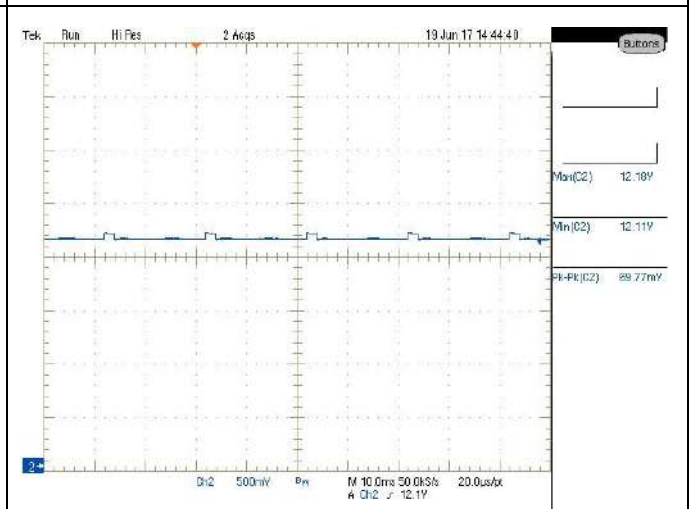

Fig : 4 (18:2ms)

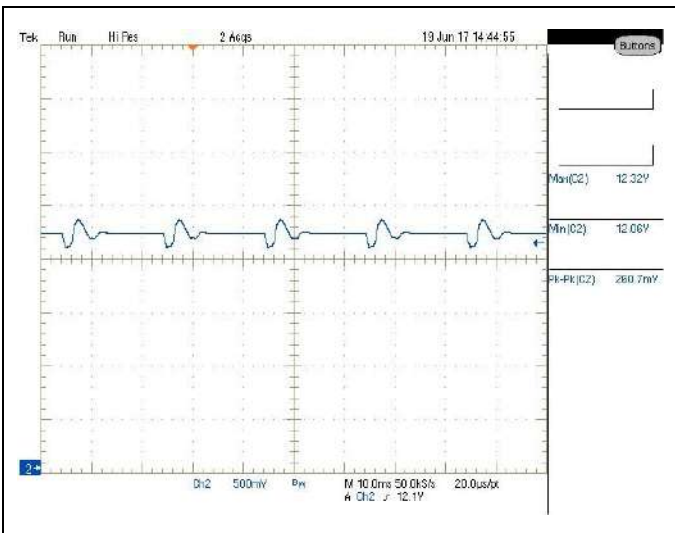

Fig : 5 (18:2ms)

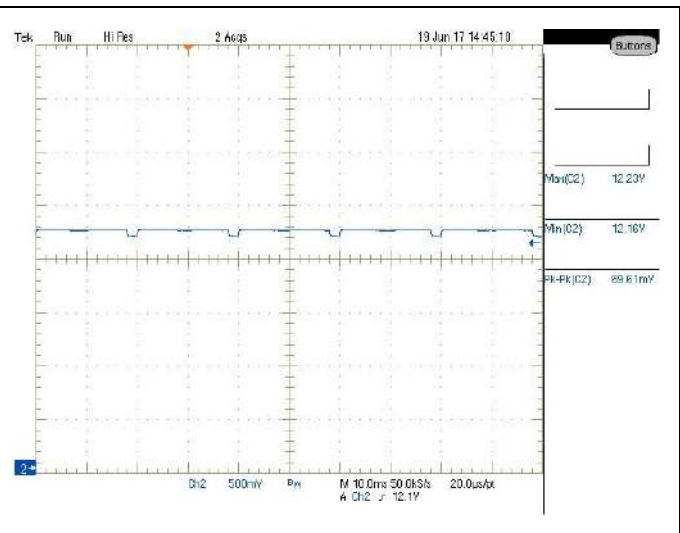

Fig : 6 (18:2ms)

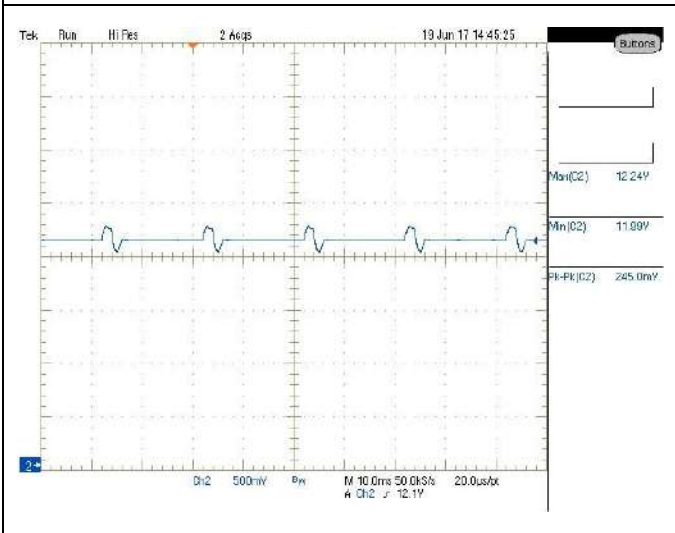

Fig : 7 (18:2ms)

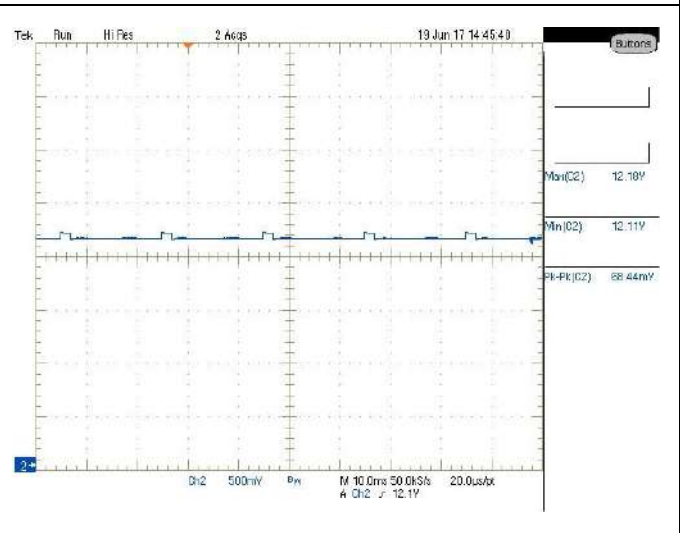

Fig : 8 (18:2ms)

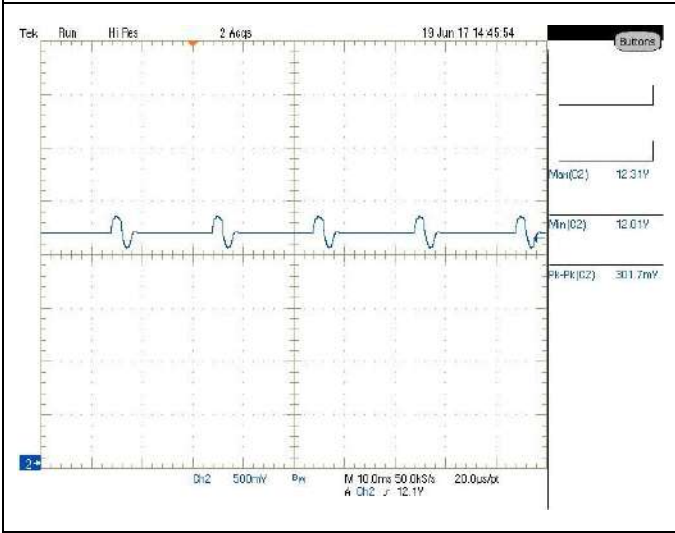

Fig : 9 (2:18ms)

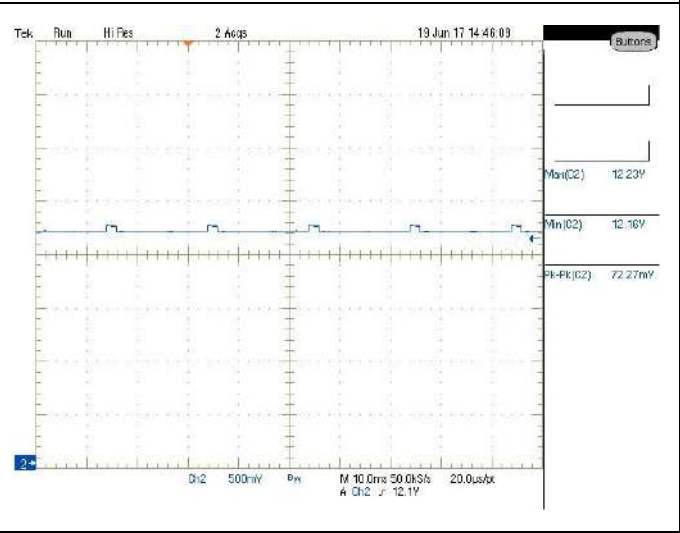

Fig : 10 (2:18ms)

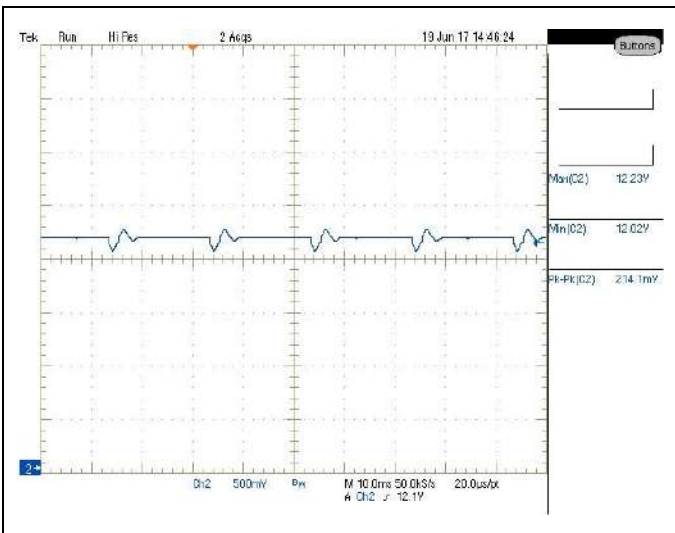

Fig : 11 (2:18ms)

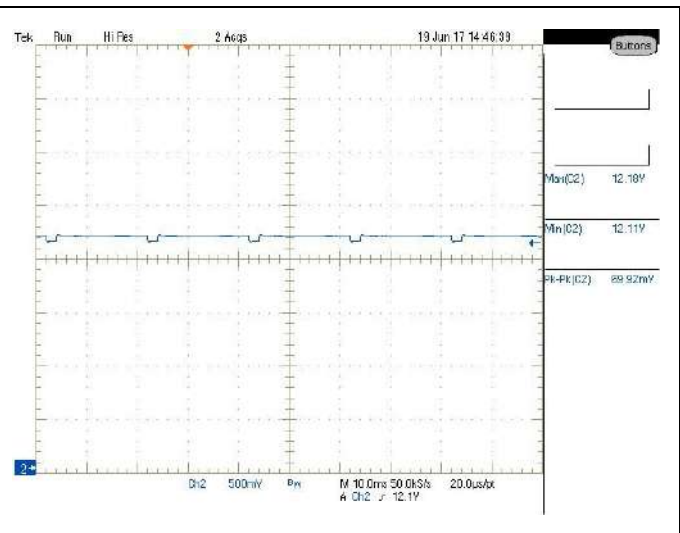

Fig : 12 (2:18ms)

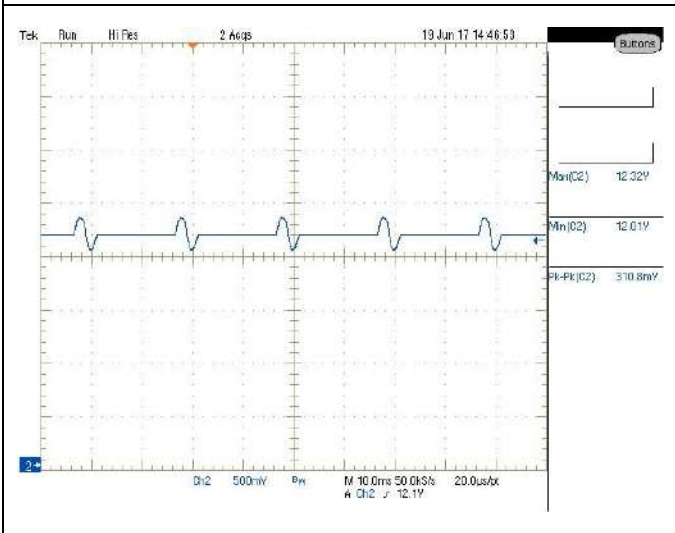

Fig : 13 (2:18ms)

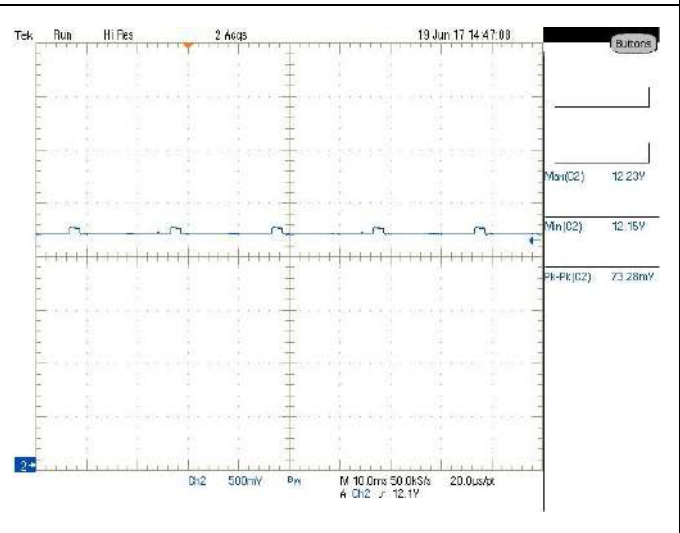

Fig : 14 (2:18ms)

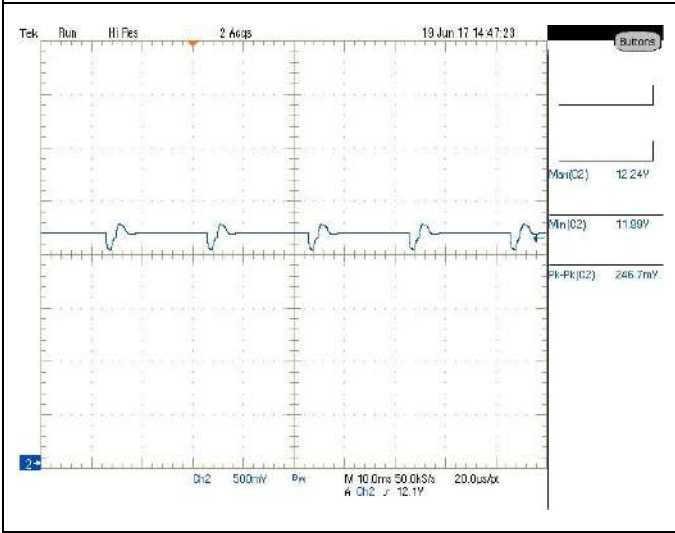

Fig : 15 (2:18ms)

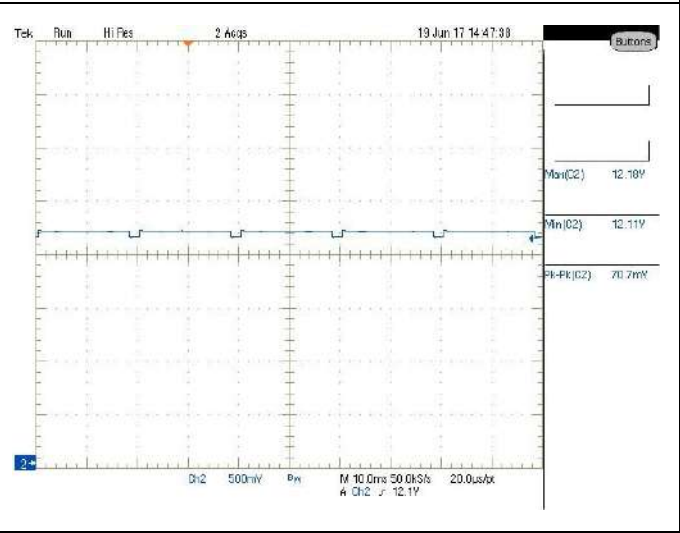

Fig : 16 (2:18ms)

12Vsb Dynamic (10KHz, 0.025:0.075 mS)									
Input Voltage	Output			Limit		Test Result		Pass / Fail	Remark
	Voltage	Load							
(Vac)		Load1(A)	Load2(A)	Min	Max	Vpk min	Vpk max		
90	+12V	0.500	0.500	11.400	12.600	12.144	12.183	PASS	Fig : 1 (0.075:0.025ms)
	+12Vaux	1.000	0.000						
90	+12V	65.000	65.000	11.400	12.600	12.153	12.233	PASS	Fig : 2 (0.075:0.025ms)
	+12Vaux	1.000	0.000						
90	+12V	0.500	0.500	11.400	12.600	12.093	12.160	PASS	Fig : 3 (0.075:0.025ms)
	+12Vaux	1.000	2.000						
90	+12V	65.000	65.000	11.400	12.600	12.095	12.185	PASS	Fig : 4 (0.075:0.025ms)
	+12Vaux	1.000	2.000						
264	+12V	0.500	0.500	11.400	12.600	12.146	12.201	PASS	Fig : 5 (0.075:0.025ms)
	+12Vaux	1.000	0.000						
264	+12V	65.000	65.000	11.400	12.600	12.151	12.232	PASS	Fig : 6 (0.075:0.025ms)
	+12Vaux	1.000	0.000						
264	+12V	0.500	0.500	11.400	12.600	12.093	12.160	PASS	Fig : 7 (0.075:0.025ms)
	+12Vaux	1.000	2.000						
264	+12V	65.000	65.000	11.400	12.600	12.099	12.191	PASS	Fig : 8 (0.075:0.025ms)
	+12Vaux	1.000	2.000						
90	+12V	0.500	0.500	11.400	12.600	12.138	12.191	PASS	Fig : 9 (0.025:0.075ms)
	+12Vaux	1.000	0.000						
90	+12V	65.000	65.000	11.400	12.600	12.150	12.234	PASS	Fig : 10 (0.025:0.075ms)
	+12Vaux	1.000	0.000						
90	+12V	0.500	0.500	11.400	12.600	12.095	12.161	PASS	Fig : 11 (0.025:0.075ms)
	+12Vaux	1.000	2.000						
90	+12V	65.000	65.000	11.400	12.600	12.097	12.186	PASS	Fig : 12 (0.025:0.075ms)
	+12Vaux	1.000	2.000						
264	+12V	0.500	0.500	11.400	12.600	12.125	12.184	PASS	Fig : 13 (0.025:0.075ms)
	+12Vaux	1.000	0.000						
264	+12V	65.000	65.000	11.400	12.600	12.145	12.226	PASS	Fig : 14 (0.025:0.075ms)
	+12Vaux	1.000	0.000						
264	+12V	0.500	0.500	11.400	12.600	12.094	12.162	PASS	Fig : 15 (0.025:0.075ms)
	+12Vaux	1.000	2.000						
264	+12V	65.000	65.000	11.400	12.600	12.104	12.192	PASS	Fig : 16 (0.025:0.075ms)
	+12Vaux	1.000	2.000						

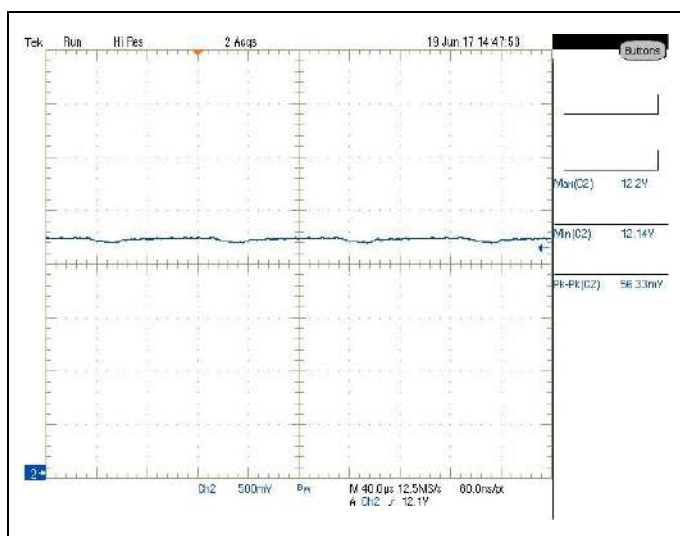

Fig : 1 (0.075:0.025ms)

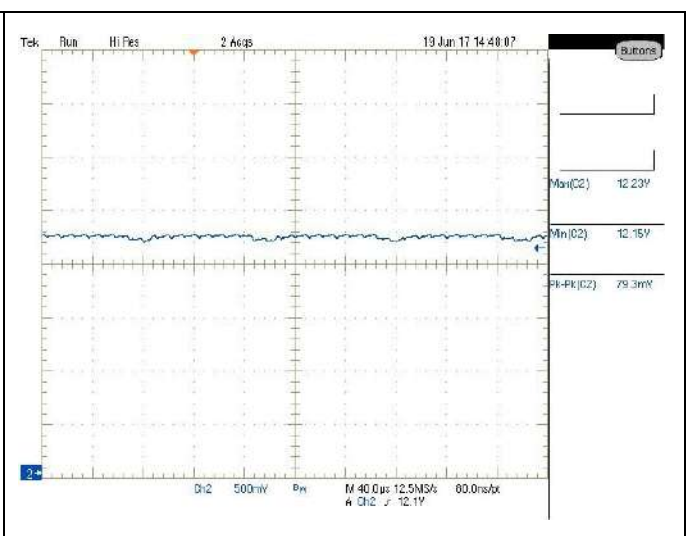

Fig : 2 (0.075:0.025ms)

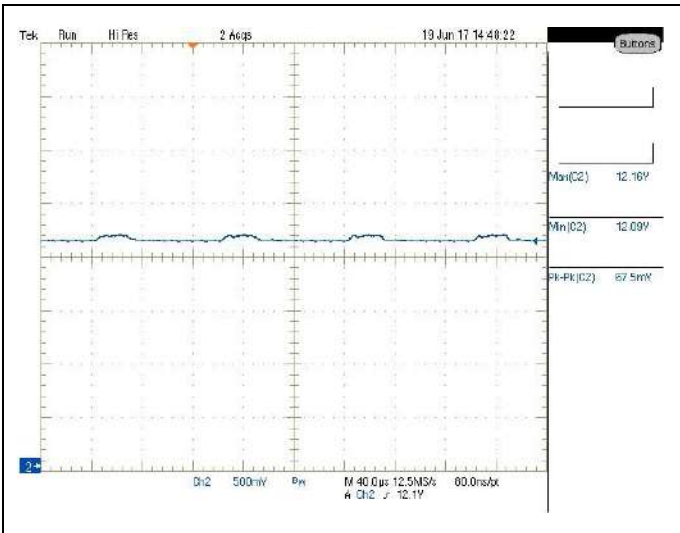

Fig : 3 (0.075:0.025ms)

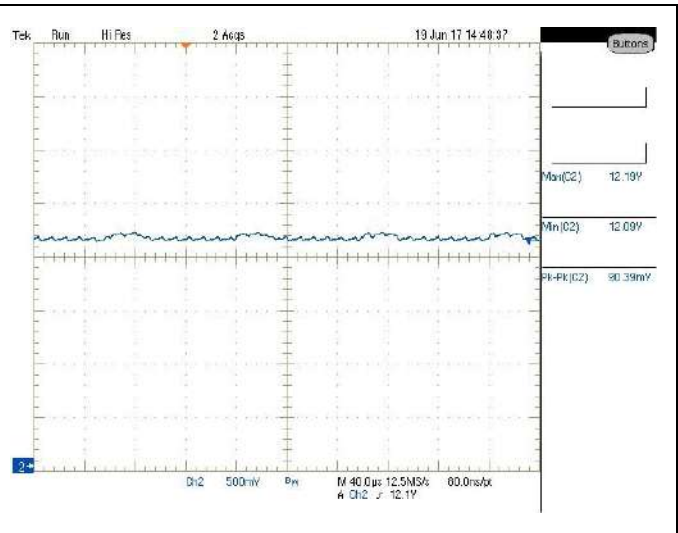

Fig : 4 (0.075:0.025ms)

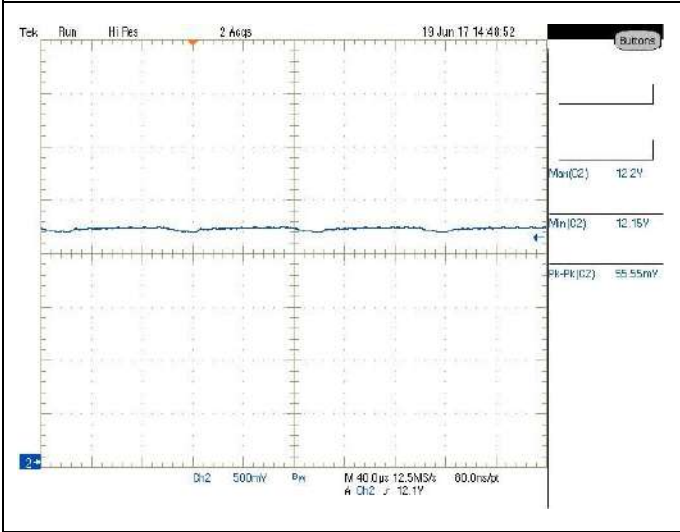

Fig : 5 (0.075:0.025ms)

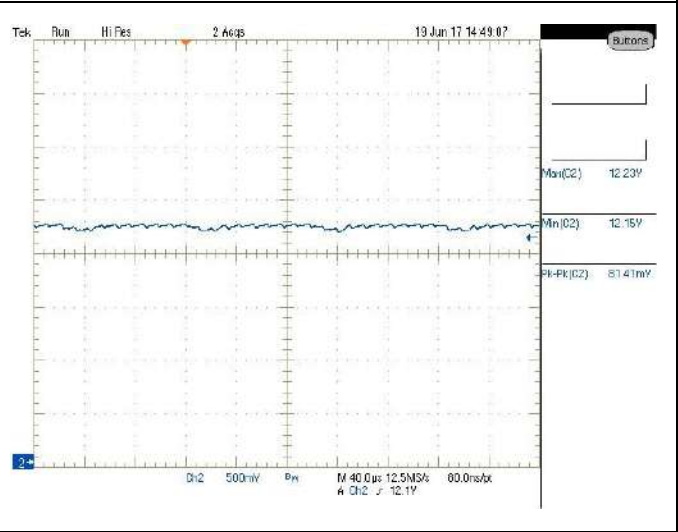

Fig : 6 (0.075:0.025ms)

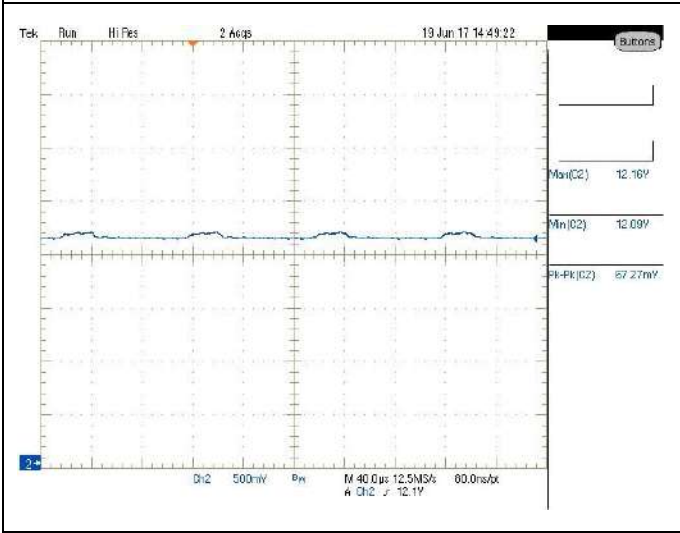

Fig : 7 (0.075:0.025ms)

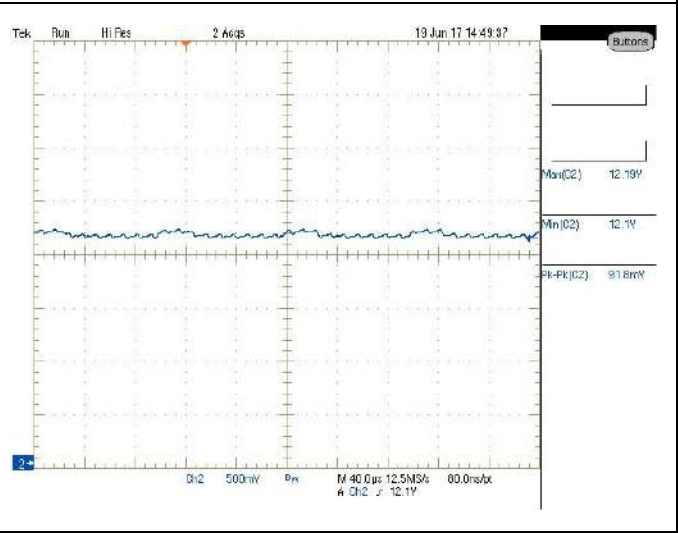

Fig : 8 (0.075:0.025ms)

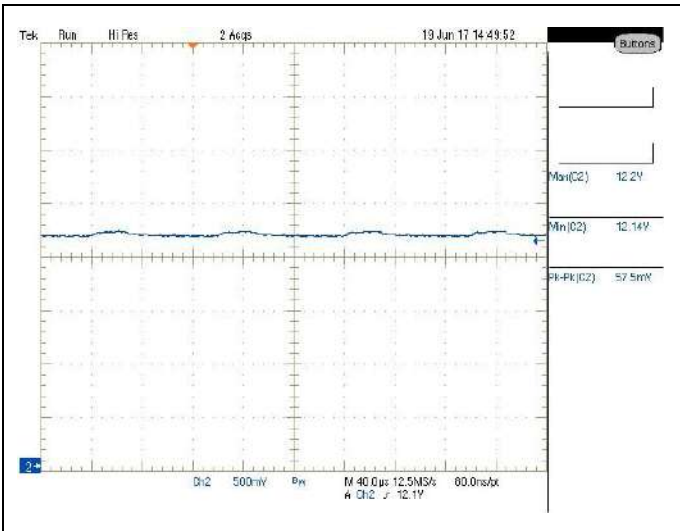

Fig : 9 (0.025:0.075ms)

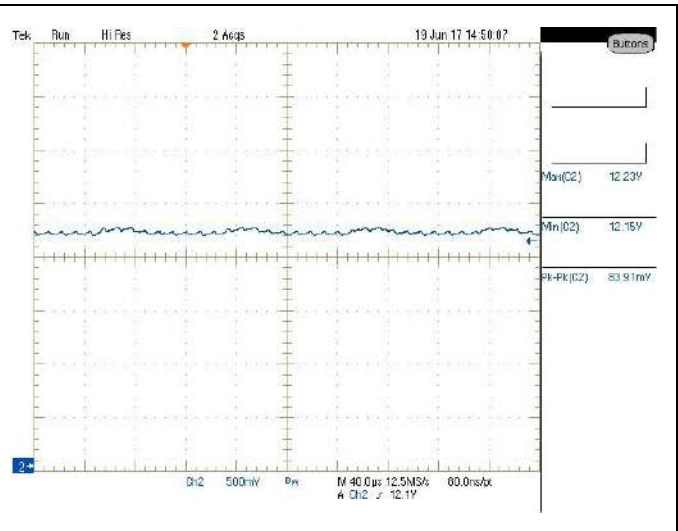

Fig : 10 (0.025:0.075ms)

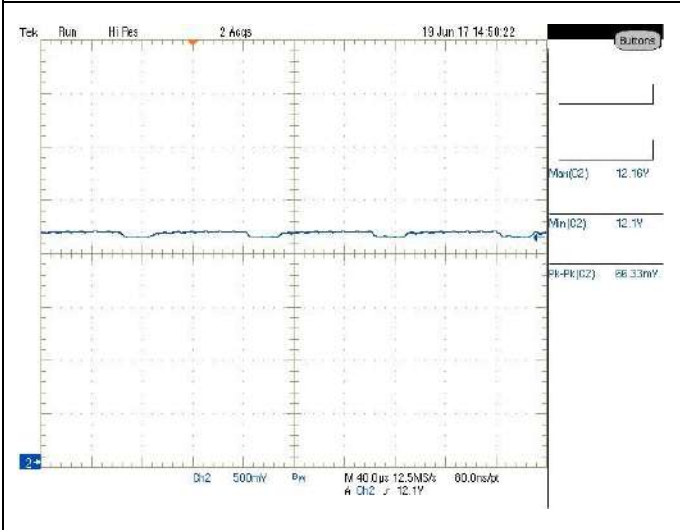

Fig : 11 (0.025:0.075ms)

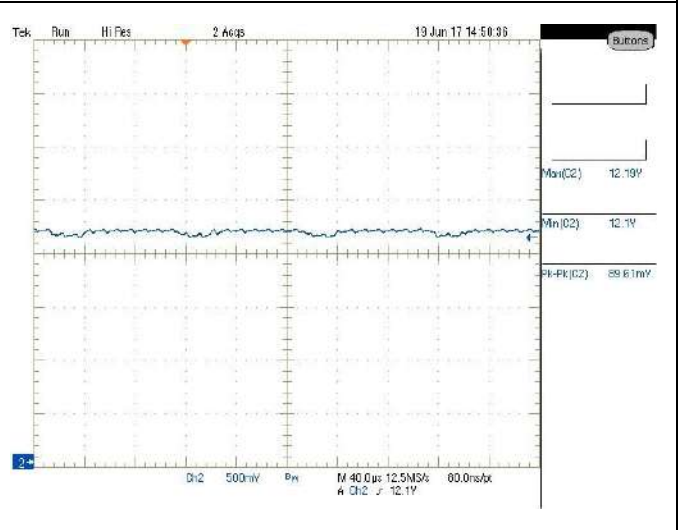

Fig : 12 (0.025:0.075ms)

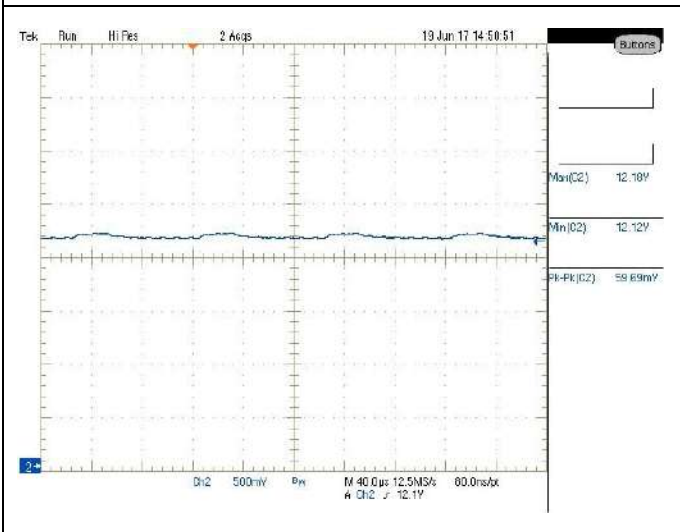

Fig : 13 (0.025:0.075ms)

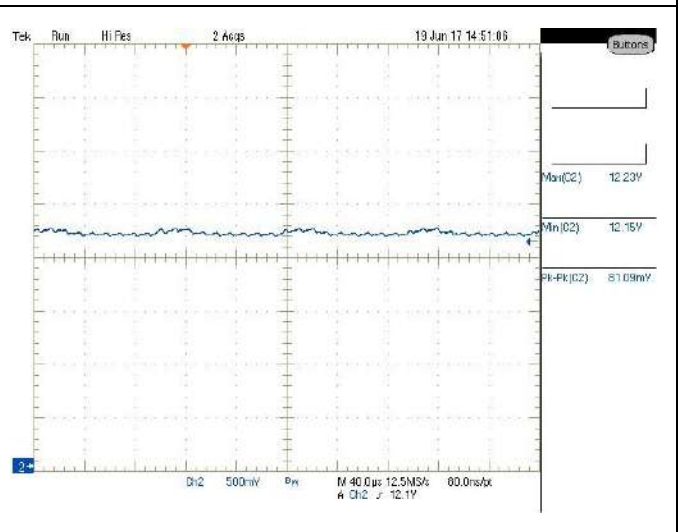

Fig : 14 (0.025:0.075ms)

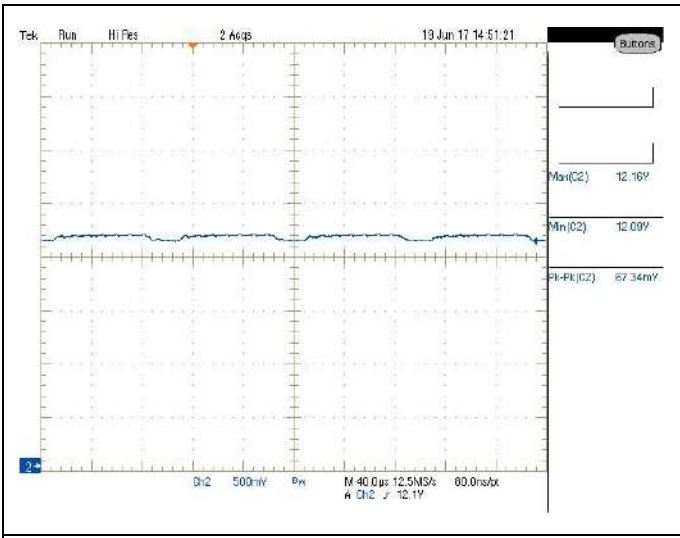

Fig : 15 (0.025:0.075ms)

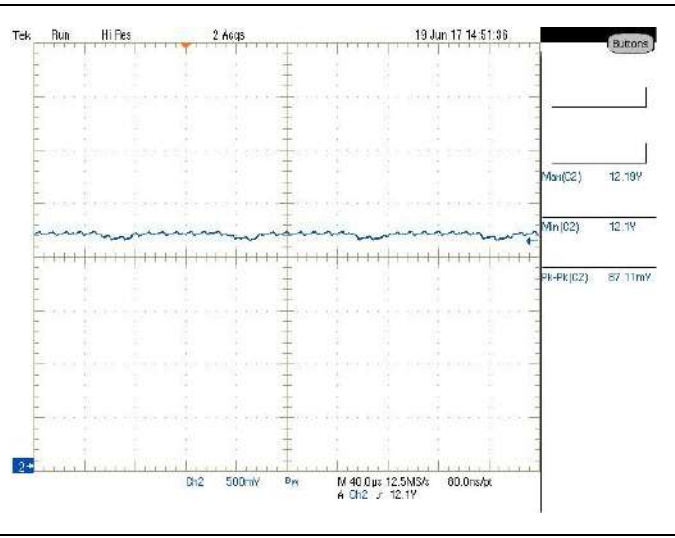
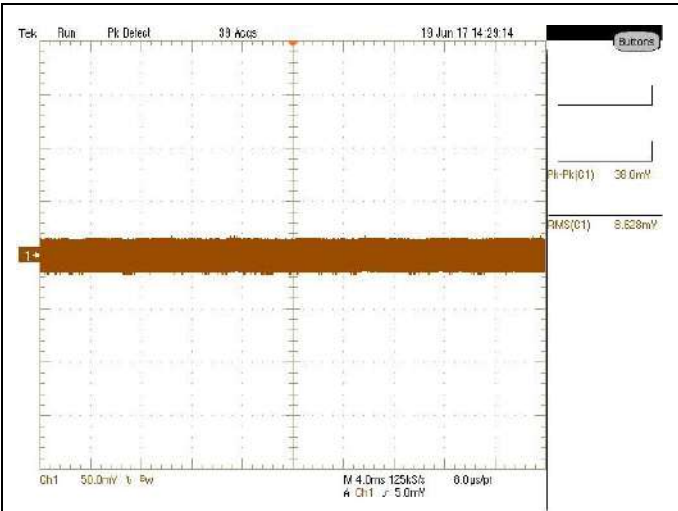
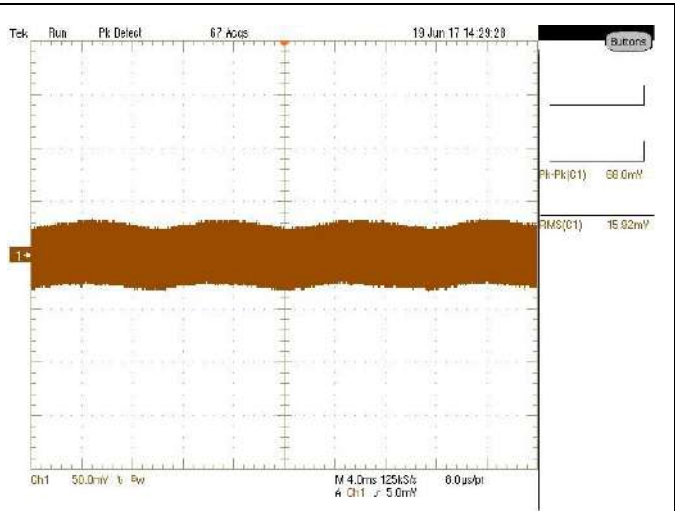

Fig : 16 (0.025:0.075ms)

+12V Ripple & Noise						
Input Voltage (Vac)	Output		Limit		Test Result (mVp-p)	Pass/Fail
	Voltage	Load(A)	Min	Max		
90	+12V	0.50	*	120.00	36.00	PASS
	+12Vaux	0.10				
90	+12V	65.00	*	120.00	68.00	PASS
	+12Vaux	2.00				
264	+12V	0.50	*	120.00	36.00	PASS
	+12Vaux	0.10				
264	+12V	65.00	*	120.00	66.00	PASS
	+12Vaux	2.00				



90Vac-Min Load--CH1: +12V



90Vac-Max Load--CH1: +12V

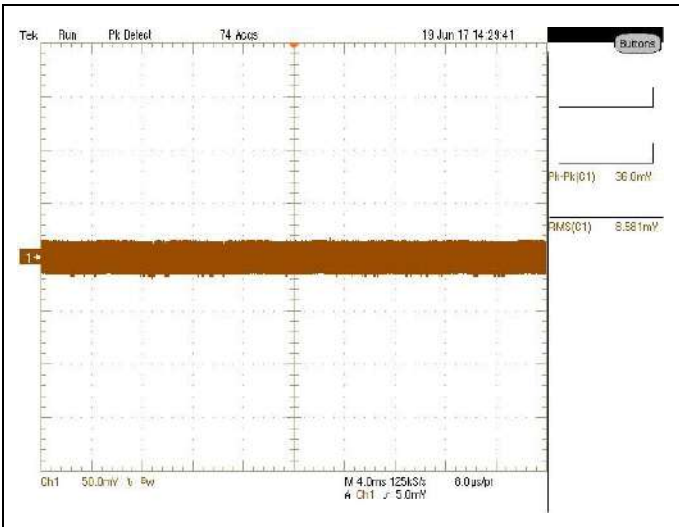

264Vac-Min Load--CH1: +12V

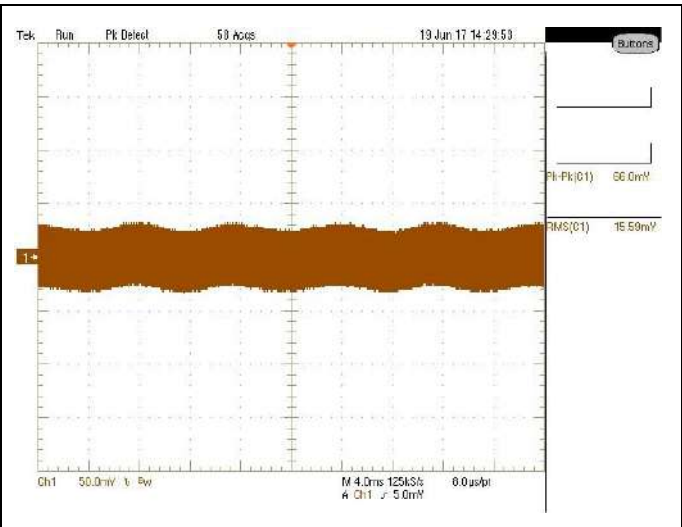

264Vac-Max Load--CH1: +12V

+12Vsb Ripple & Noise

Input Voltage (Vac)	Output		Limit		Test Result (mVp-p)	Pass/Fail
	Voltage	Load(A)	Min	Max		
90	+12V	0.50	*	120.00	26.000	PASS
	+12Vaux	0.10				
90	+12V	65.00	*	120.00	74.000	PASS
	+12Vaux	2.00				
90	+12V	0.00	*	120.00	24.000	PASS
	+12Vaux	0.10				
90	+12V	0.00	*	120.00	26.000	PASS
	+12Vaux	2.00				
264	+12V	0.50	*	120.00	26.000	PASS
	+12Vaux	0.10				
264	+12V	65.00	*	120.00	76.000	PASS
	+12Vaux	2.00				
264	+12V	0.00	*	120.00	22.000	PASS
	+12Vaux	0.10				
264	+12V	0.00	*	120.00	24.000	PASS
	+12Vaux	2.00				

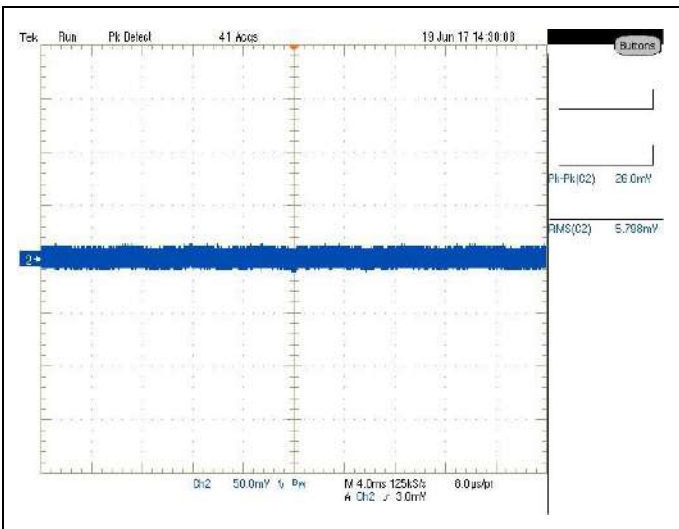

90Vac-Min Load--CH2: +12Vsb

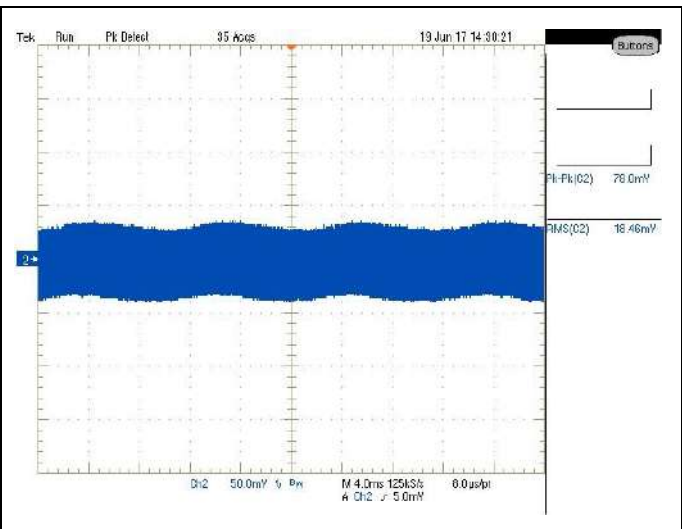

90Vac-Max Load--CH2: +12Vsb

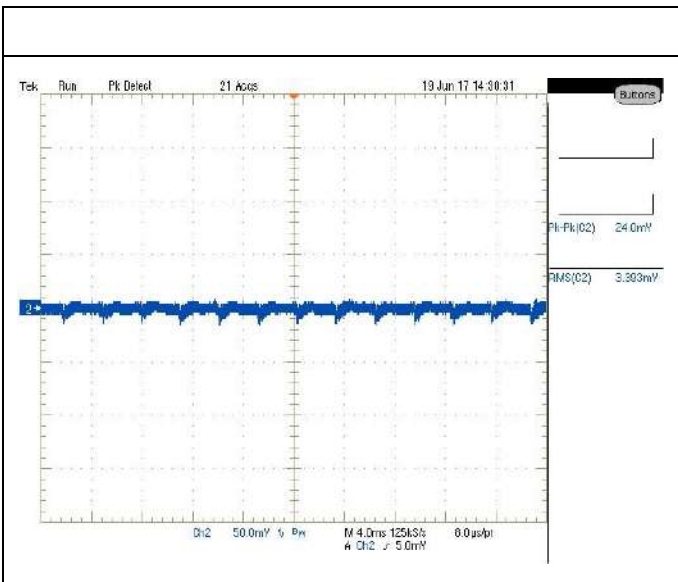

90Vac-Standby Mode Min--CH2: +12Vsb



90Vac-Standby Mode Max--CH2: +12Vsb

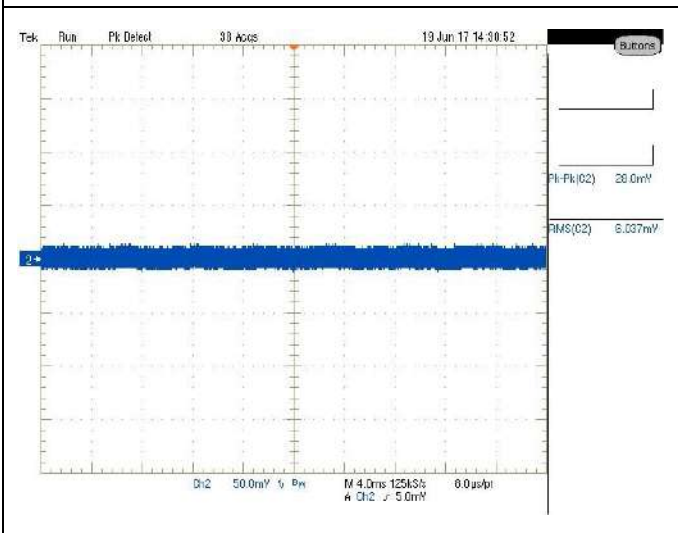

264Vac-Min Load--CH2: +12Vsb

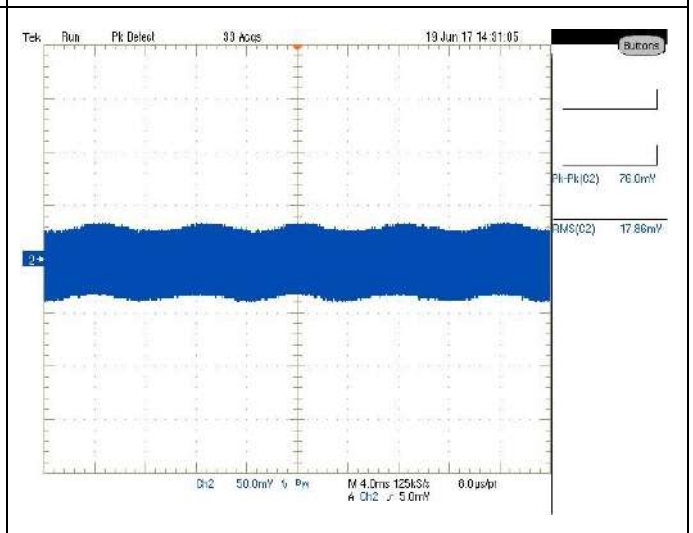

264Vac-Max Load--CH2: +12Vsb

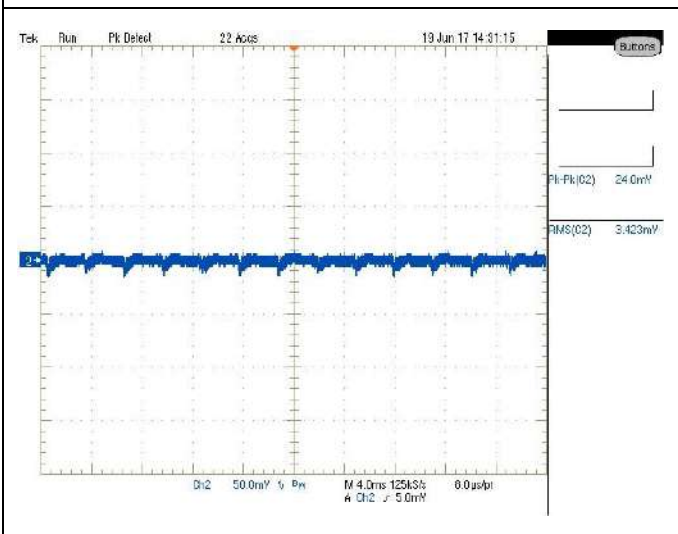

264Vac-Standby Load Min--CH2: +12Vsb

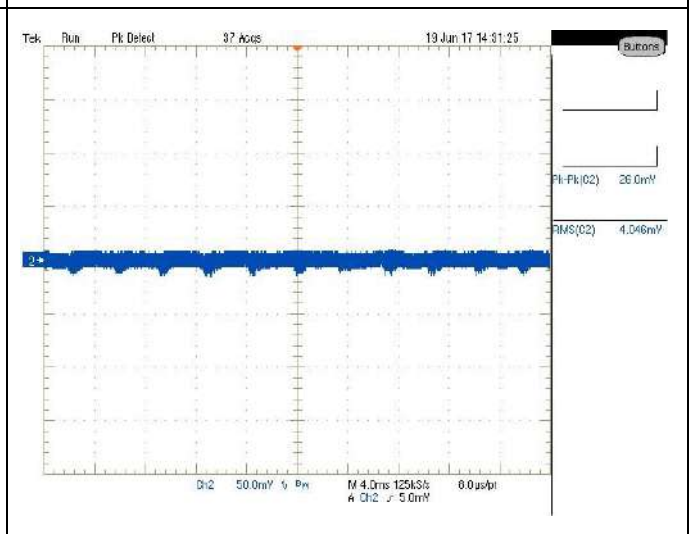

264Vac-Standby Load Max--CH2: +12Vsb

+12V Rise time & Overshoot

Input Voltage (Vac)	Output		Limit Rise time (ms)		Limit Overshoot (Vpk)		Test Result		Pass/Fail
	Voltage	Load(A)	Min	Max	Min	Max	(mS)	(Vpk)	
90.000	+12V	0.500	2.000	70.000	11.400	12.600	17.393	12.321	PASS
	+12Vaux	0.100							
90.000	+12V	65.000	2.000	70.000	11.400	12.600	17.266	12.226	PASS
	+12Vaux	2.000							
264.000	+12V	0.500	2.000	70.000	11.400	12.600	17.417	12.319	PASS
	+12Vaux	0.100							
264.000	+12V	65.000	2.000	70.000	11.400	12.600	17.277	12.234	PASS
	+12Vaux	2.000							

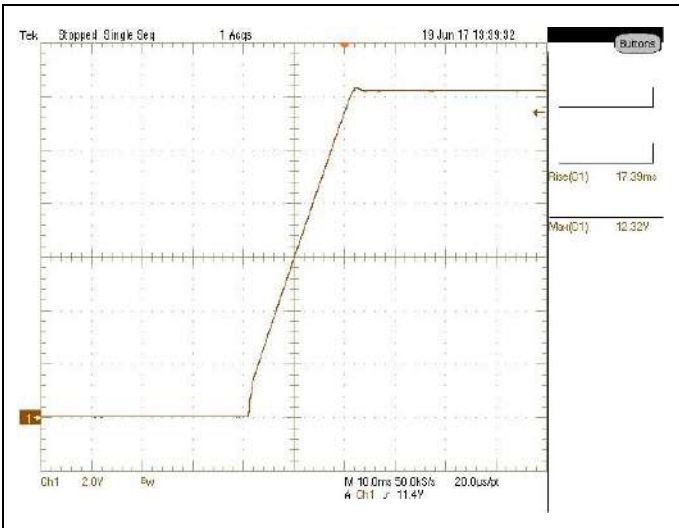

90Vac/47Hz-Min Load-Tvout_rise, CH1:12V

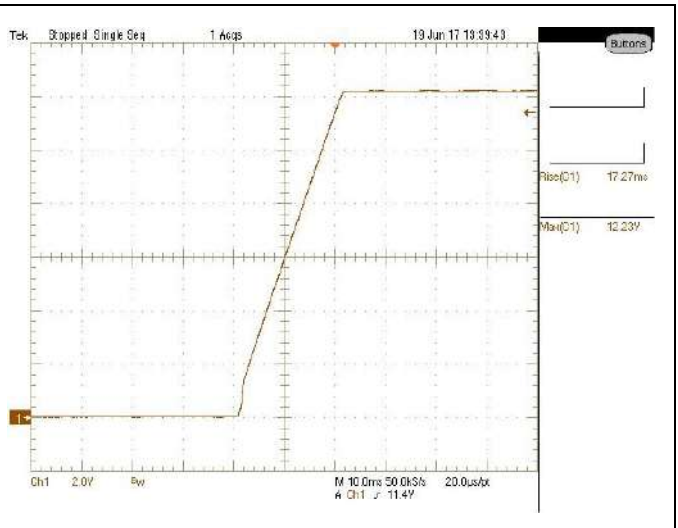

90Vac/47Hz-Max Load-Tvout_rise, CH1:12V

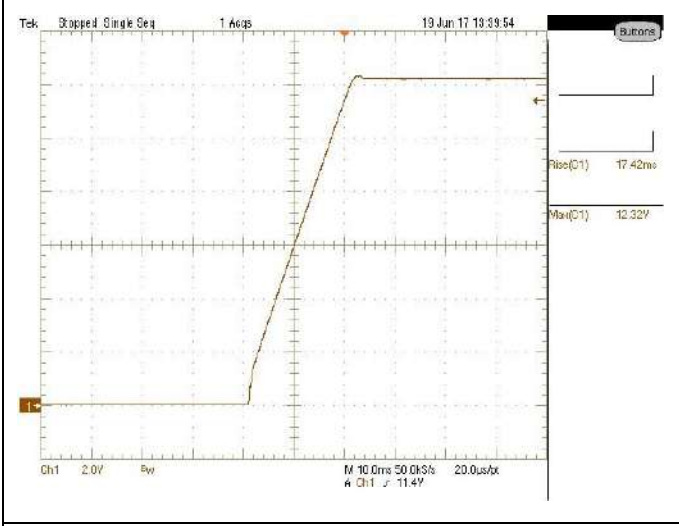

264Vac/63Hz-Min Load-Tvout_rise, CH1:12V

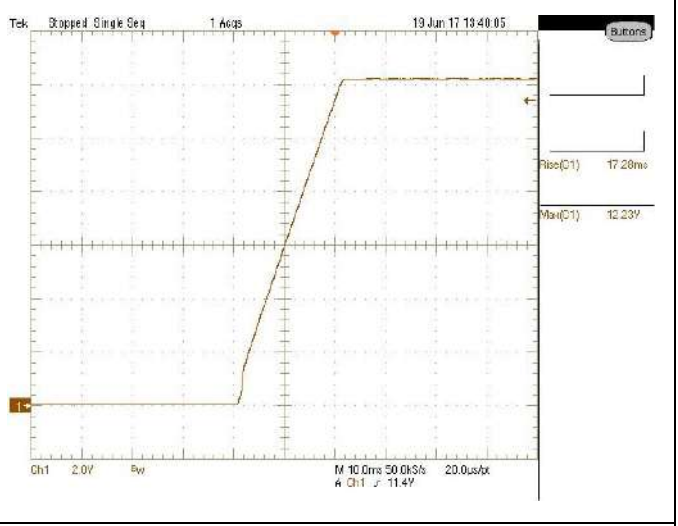

264Vac/63Hz-Max Load-Tvout_rise, CH1:12V

+12Vsb Rise time & Overshoot

Input Voltage (Vac)	Output		Limit Rise time (ms)		Limit Overshoot (Vpk)		Test Result		Pass/Fail
	Voltage	Load(A)	Min	Max	Min	Max	(mS)	(Vpk)	

90.000	+12V	0.500	1.000	25.000	11.400	12.600	2.461	12.311	PASS
	+12Vaux	0.100							
90.000	+12V	65.000	1.000	25.000	11.400	12.600	2.022	12.145	PASS
	+12Vaux	2.000							
264.000	+12V	0.500	1.000	25.000	11.400	12.600	2.465	12.310	PASS
	+12Vaux	0.100							
264.000	+12V	65.000	1.000	25.000	11.400	12.600	2.021	12.148	PASS
	+12Vaux	2.000							

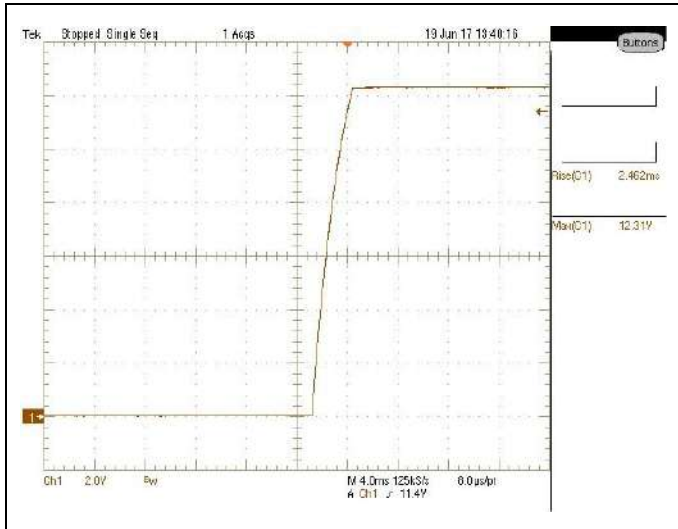

90Vac/47Hz-Min Load-Tvout_rise, CH1:12Vsb

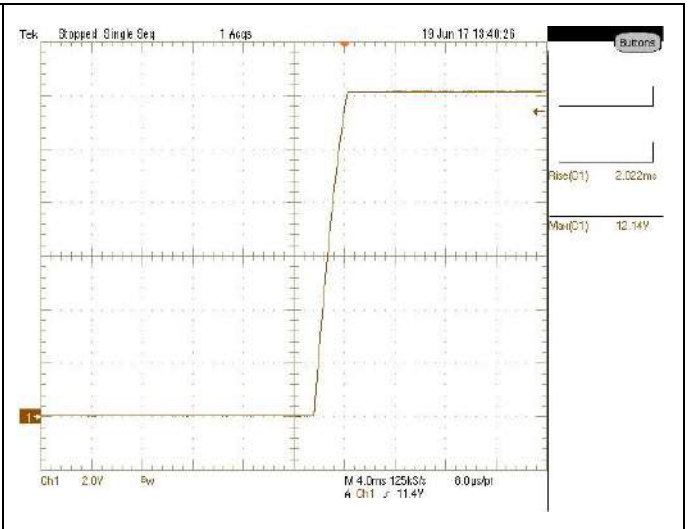

90Vac/47Hz-Max Load-Tvout_rise, CH1:12Vsb

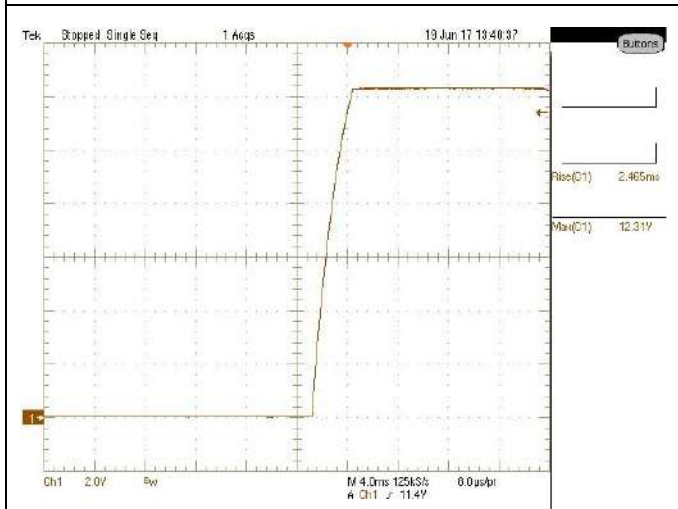

264Vac/63Hz-Min Load-Tvout_rise, CH1:12Vsb

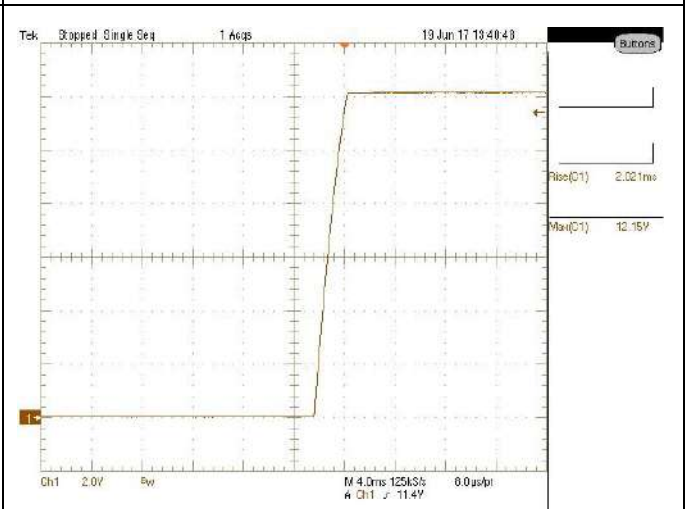

264Vac/63Hz-Max Load-Tvout_rise, CH1:12Vsb

+12V Fall Time & Undershoot

Input Voltage (Vac)	Output		Limit Fall time (ms)		Limit Undershoot (Vpk)		Test Result		Pass/Fail
	Voltage	Load(A)	Min	Max	Min	Max	(mS)	(Vpk)	
90.000	+12V	65.000	*	*	*	*	0.343	-0.512	PASS
	+12Vaux	2.000							
264.000	+12V	65.000	*	*	*	*	0.344	-0.507	PASS
	+12Vaux	2.000							

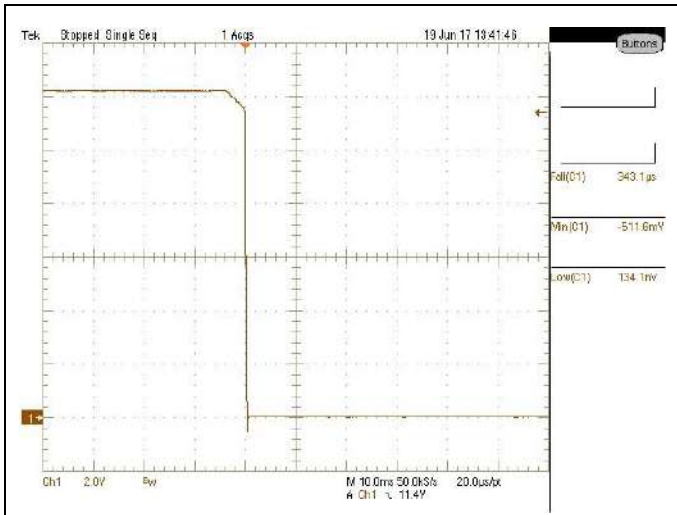

90Vac/47Hz-Max Load-12V Fall Time, CH1:12V

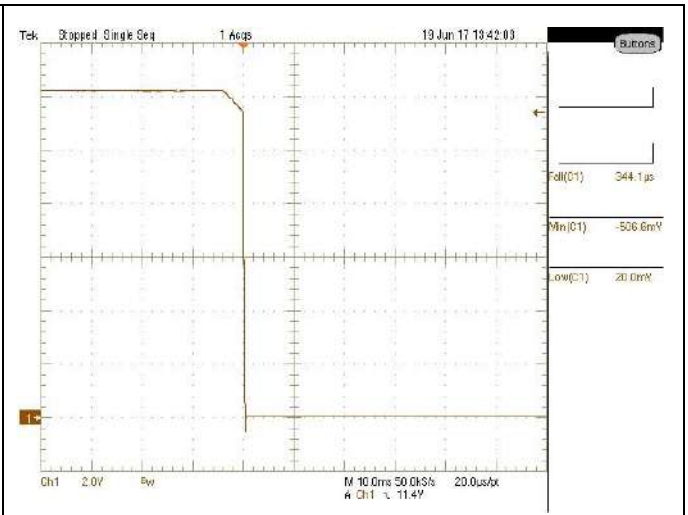

264Vac/63Hz-Max Load-12V Fall Time, CH1:12V

+12Vsb Fall Time & Undershoot

Input Voltage (Vac)	Output		Limit Fall time (ms)		Limit Undershoot (Vpk)		Test Result		Pass/Fail
	Voltage	Load(A)	Min	Max	Min	Max	(mS)	(Vpk)	
90.000	+12V	0.500	*	*	*	*	19.172	0.024	PASS
	+12Vaux	0.100							
90.000	+12V	65.000	*	*	*	*	2.584	0.020	PASS
	+12Vaux	2.000							
264.000	+12V	0.500	*	*	*	*	31.257	0.020	PASS
	+12Vaux	0.100							
264.000	+12V	65.000	*	*	*	*	2.689	0.022	PASS
	+12Vaux	2.000							

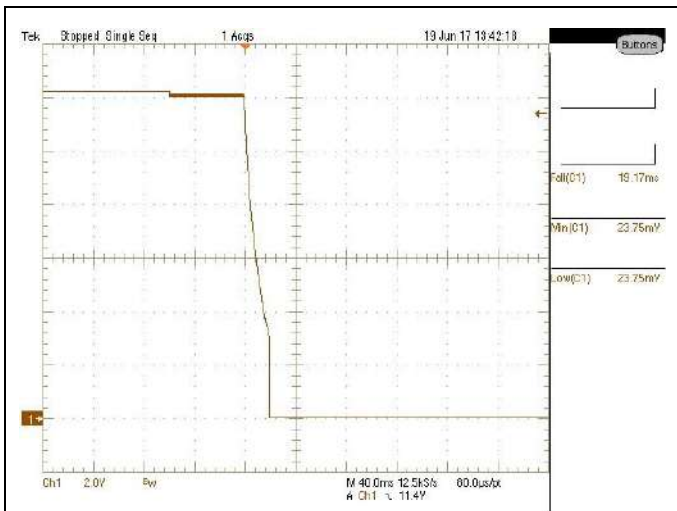

90Vac/47Hz-Min Load-12Vsb Fall Time, CH1:12Vsb

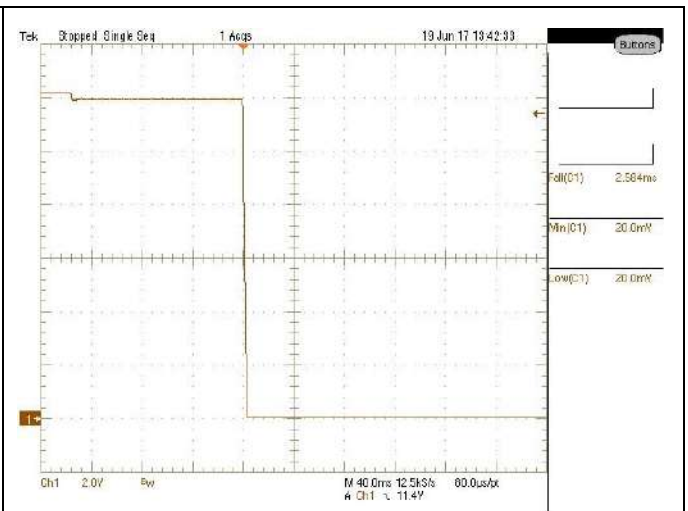

90Vac/47Hz-Max Load-12Vsb Fall Time, CH1:12Vsb

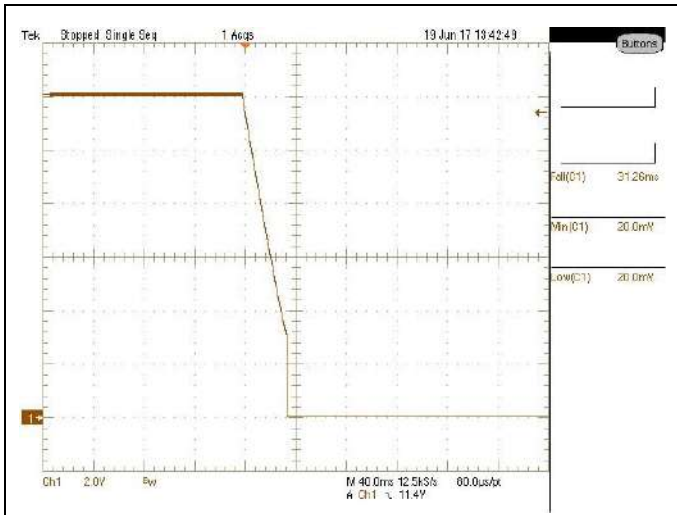

264Vac/63Hz-Min Load-12Vsb Fall Time, CH1:12Vsb

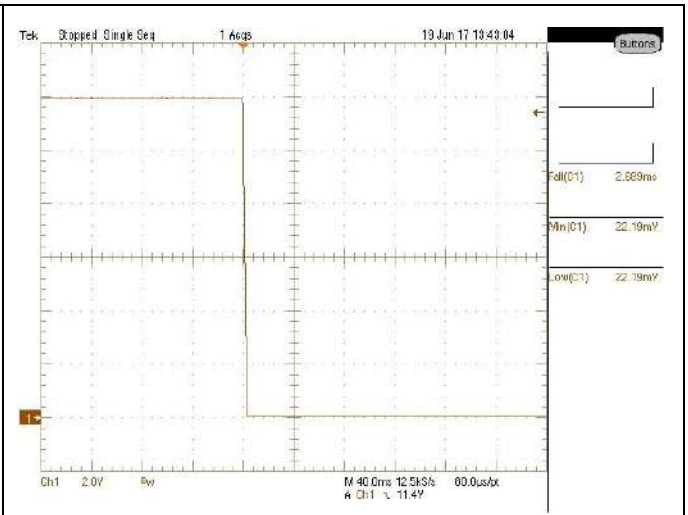

264Vac/63Hz-Max Load-12Vsb Fall Time, CH1:12Vsb

+12V Overshoot (CR Mode)

Input Voltage (Vac)	Output		Limit Rise time (Vpk)		Limit Overshoot (Vos)		Test Result		Pass/Fail
	Voltage	Load(Ω)	Min	Max	Min	Max	(Vpk)	(Vos)	
90.000	+12V	24.000	11.400	12.600	*	1.200	12.342	0.142	PASS
	+12Vaux	100.000							
90.000	+12V	0.185	11.400	12.600	*	1.200	12.232	0.012	PASS
	+12Vaux	6.000							
264.000	+12V	24.000	11.400	12.600	*	1.200	12.337	0.137	PASS
	+12Vaux	100.000							
264.000	+12V	0.185	11.400	12.600	*	1.200	12.233	0.053	PASS
	+12Vaux	6.000							

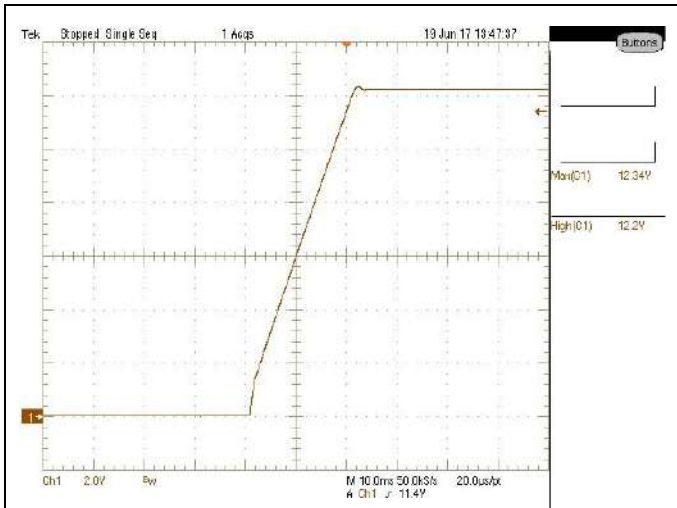

90Vac/47Hz-Min Load-+12V Overshoot (CR Mode)CH1:12V

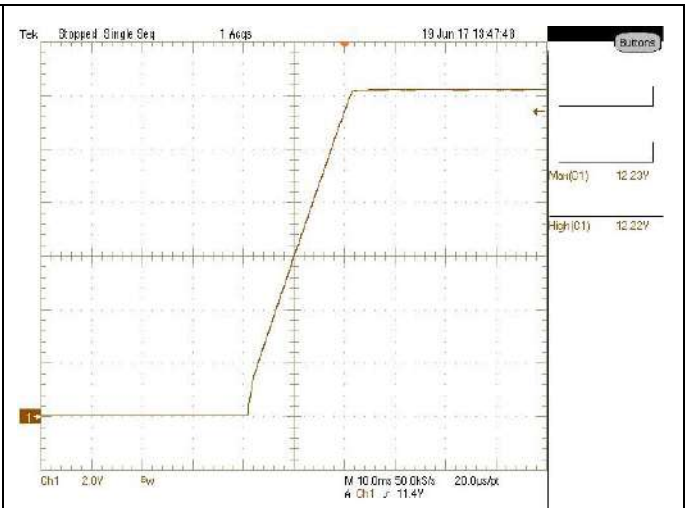

90Vac/47Hz-Max Load-+12V Overshoot (CR Mode)CH1:12V

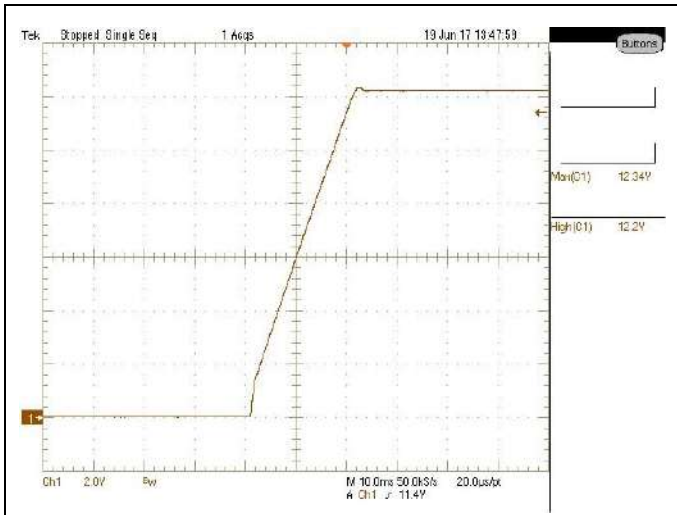

264Vac/63Hz-Min Load-+12V Overshoot (CR Mode)CH1:12V

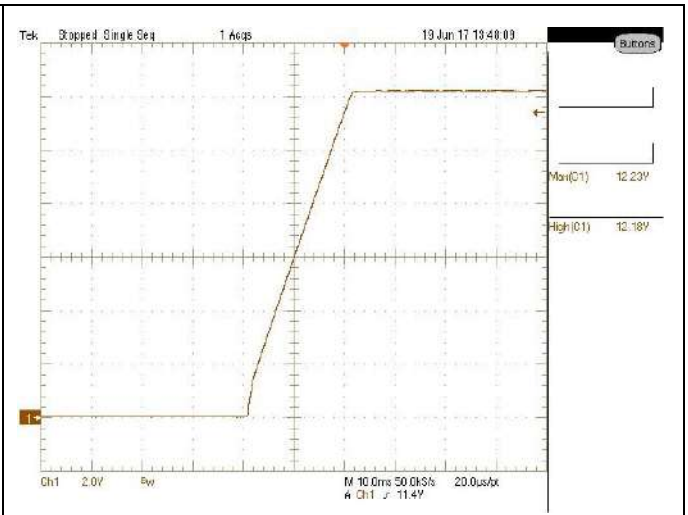

264Vac/63Hz-Max Load-+12V Overshoot (CR Mode)CH1:12V

12Vsb Overshoot (CR Mode)

Input Voltage (Vac)	Output		Limit Rise time (Vpk)		Limit Overshoot (Vos)		Test Result		Pass/Fail
	Voltage	Load(Ω)	Min	Max	Min	Max	(Vpk)	(Vos)	
90.000	+12V	24.000	11.400	12.600	*	1.200	12.301	0.041	PASS
	+12Vaux	100.000							
90.000	+12V	0.185	11.400	12.600	*	1.200	12.144	0.044	PASS
	+12Vaux	6.000							
264.000	+12V	24.000	11.400	12.600	*	1.200	12.299	0.039	PASS
	+12Vaux	100.000							
264.000	+12V	0.185	11.400	12.600	*	1.200	12.144	0.044	PASS
	+12Vaux	6.000							

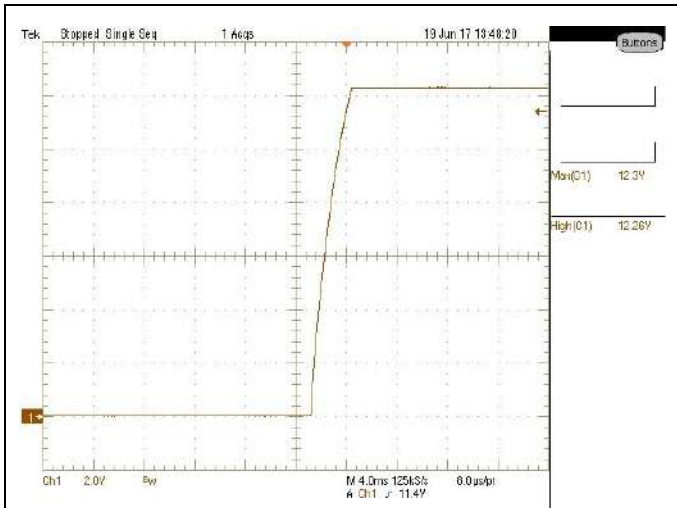

90Vac/47Hz-Min Load-+12Vsb Overshoot (CR Mode)CH1:12Vsb

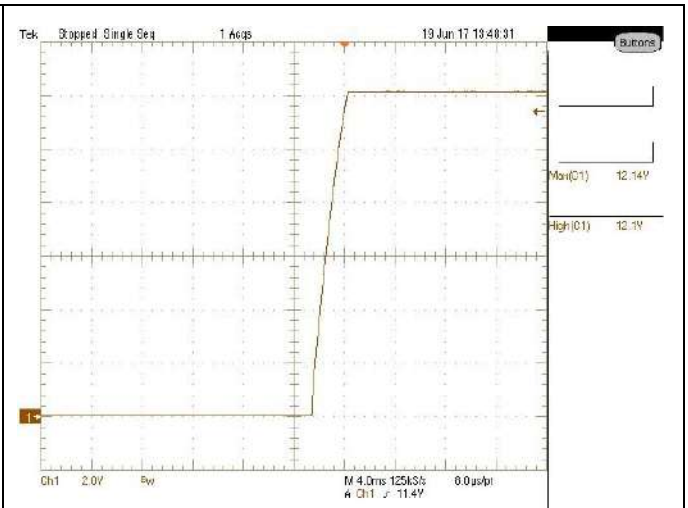

90Vac/47Hz-Max Load-+12Vsb Overshoot (CR Mode)CH1:12Vsb

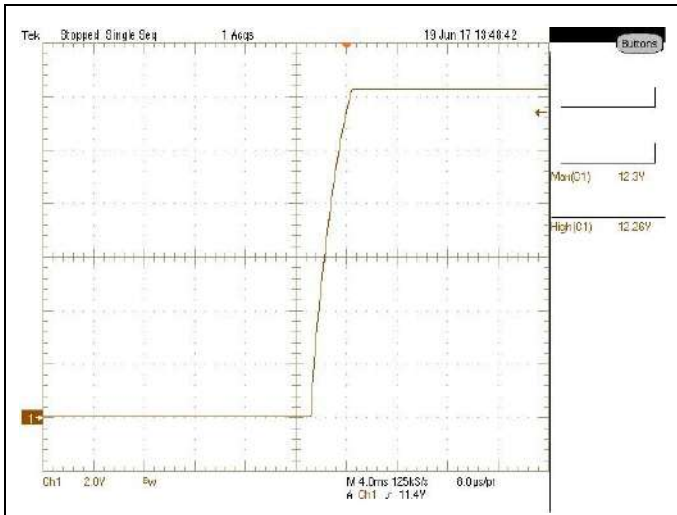

264Vac/63Hz-Min Load-+12Vsb Overshoot (CR Mode)CH1:12Vsb

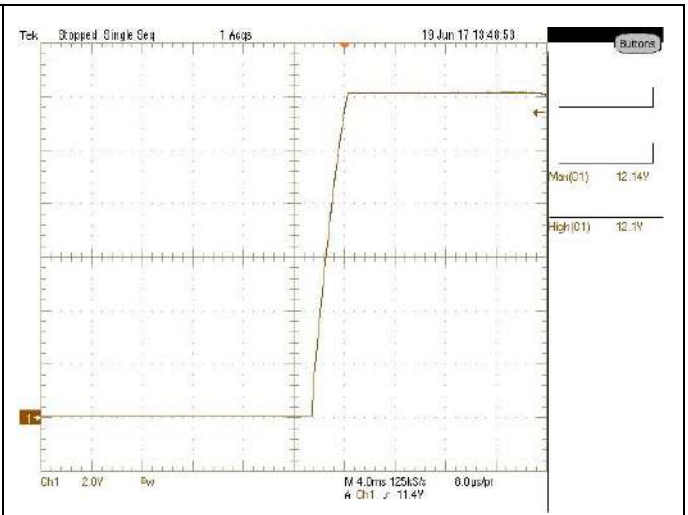

264Vac/63Hz-Max Load-+12Vsb Overshoot (CR Mode)CH1:12Vsb

+12V Undershoot

Input Voltage (Vac)	Output		Limit (Vpk)		Limit Undershoot (Vus)		Test Result		Pass/Fail
	Voltage	Load(A)	Min	Max	Min	Max	(Vpk)	(Vus)	
90.000	+12V	65.000	*	*	*	1.200	-0.887	0.907	PASS
	+12Vaux	2.000							
264.000	+12V	65.000	*	*	*	1.200	-0.903	0.923	PASS
	+12Vaux	2.000							

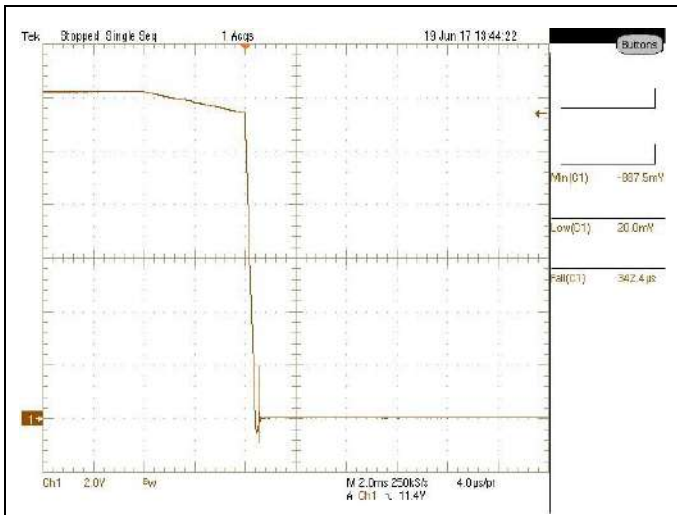

90Vac/47Hz-Max Load-12V Undershoot, CH1:12V

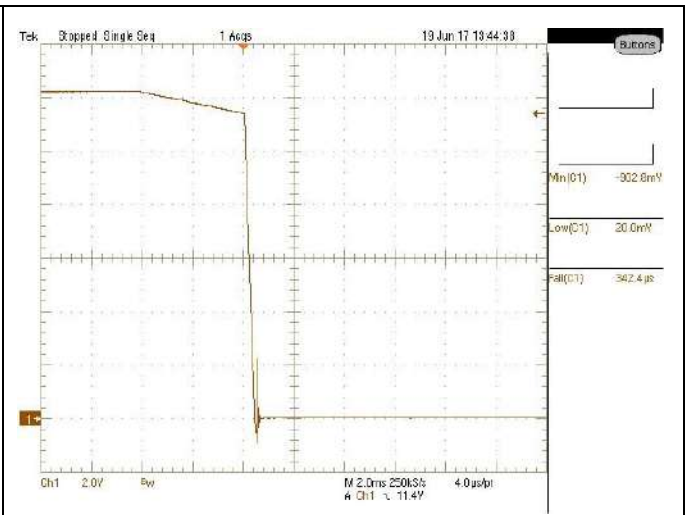

264Vac/63Hz-Max Load-12V Undershoot, CH1:12V

+12Vsb Undershoot

Input Voltage (Vac)	Output		Limit (Vpk)		Limit Undershoot (Vus)		Test Result		Pass/Fail
	Voltage	Load(A)	Min	Max	Min	Max	(Vpk)	(Vus)	
90.000	+12V	0.500	*	*	*	1.200	0.022	0.000	PASS

	+12Vaux	0.100							
90.000	+12V	65.000	*	*	*	1.200	0.020	0.013	PASS
	+12Vaux	2.000							
264.000	+12V	0.500	*	*	*	1.200	0.023	0.000	PASS
	+12Vaux	0.100							
264.000	+12V	65.000	*	*	*	1.200	0.009	0.000	PASS
	+12Vaux	2.000							

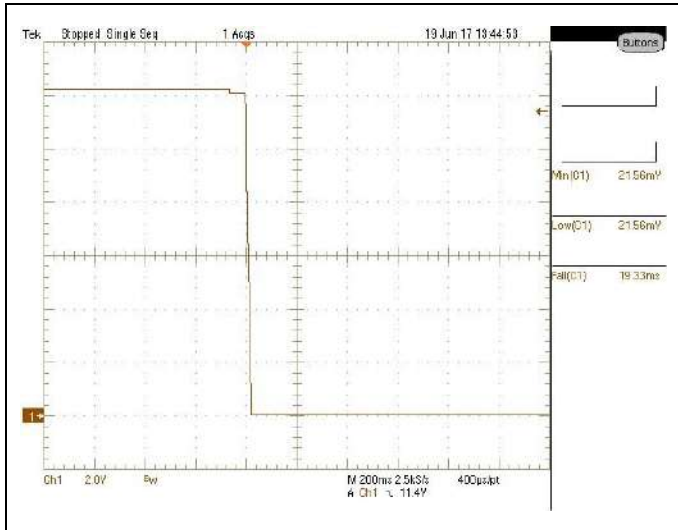

90Vac/47Hz-Min Load-12Vsb Undershoot, CH1:12Vsb

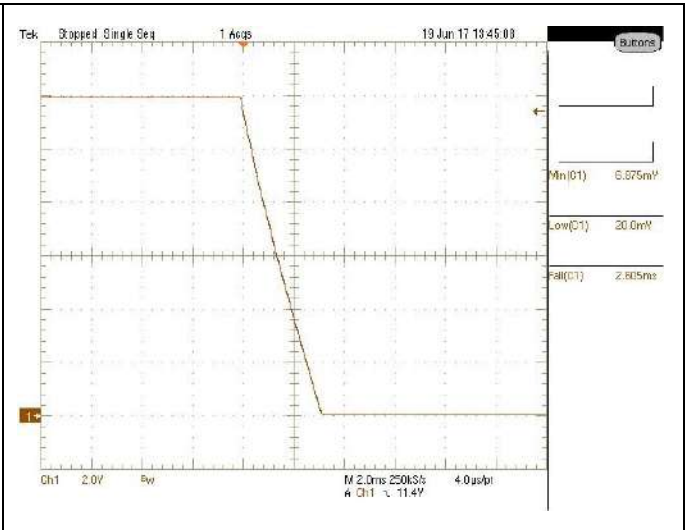

90Vac/47Hz-Max Load-12Vsb Undershoot, CH1:12Vsb

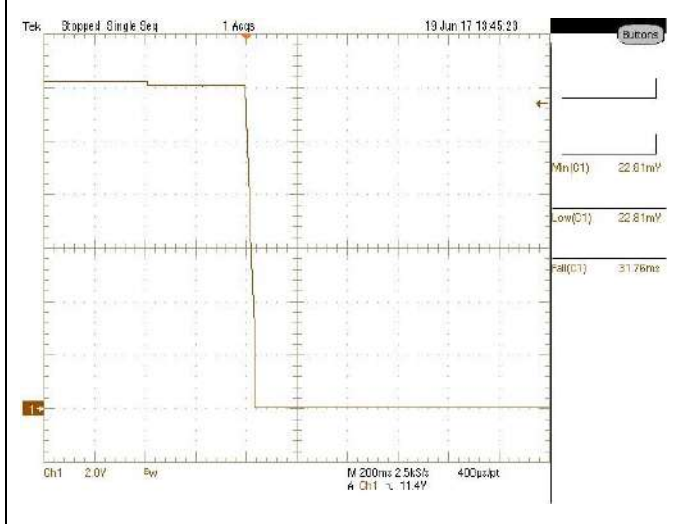

264Vac/63Hz-Min Load-12Vsb Undershoot, CH1:12Vsb

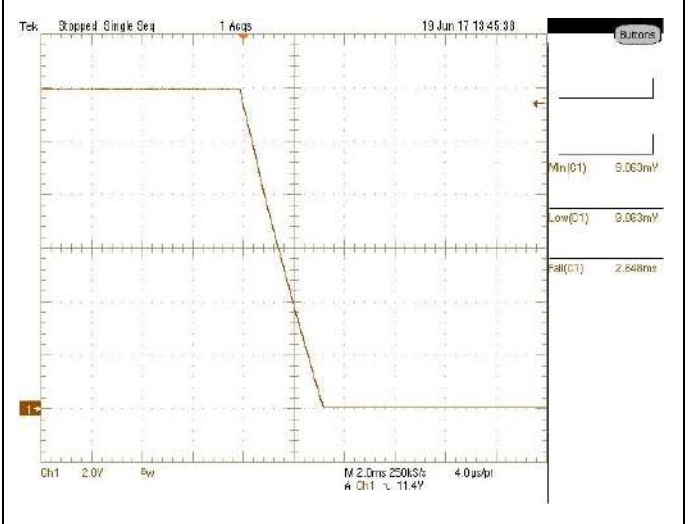

264Vac/63Hz-Max Load-12Vsb Undershoot, CH1:12Vsb

+12Vsb Turn On Delay Time						
Input Voltage (Vac)	Output		Limit (ms)		Test Result (ms)	Pass/Fail
	Voltage	Load(A)	Min	Max		
90.000	+12V	0.500	*	1500.000	1077.500	PASS
	+12Vaux	0.100				
90.000	+12V	65.000	*	1500.000	1181.500	PASS

	+12Vaux	2.000				
264.000	+12V	0.500	*	1500.000	295.100	PASS
	+12Vaux	0.100				
264.000	+12V	65.000	*	1500.000	197.500	PASS
	+12Vaux	2.000				

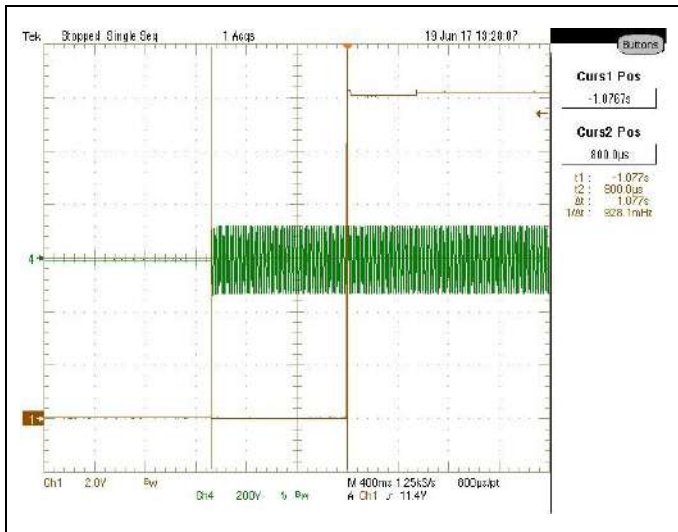

90Vac /47Hz-Min Load-Tsb_on_delay, CH1:12Vsb, CH4:Vin

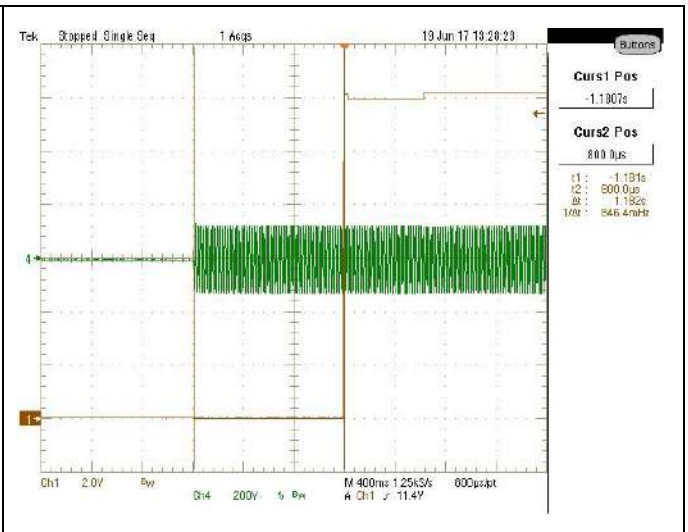

90Vac /47Hz-Max Load-Tsb_on_delay, CH1:12Vsb, CH4:Vin

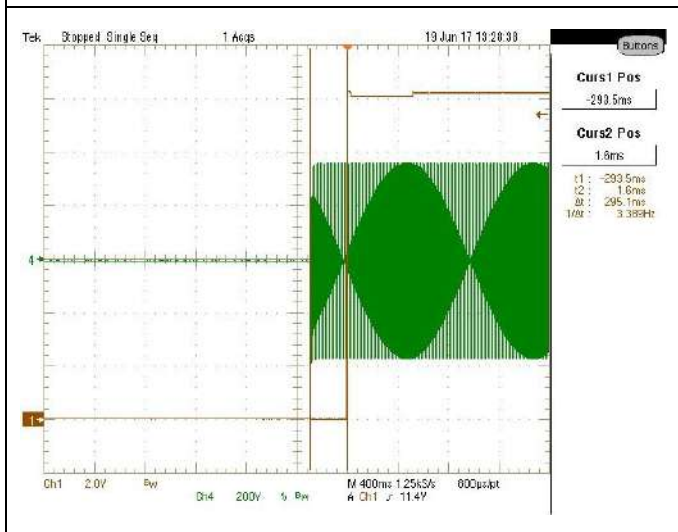

264Vac/63Hz-Min Load-Tsb_on_delay, CH1:12Vsb, CH4:Vin

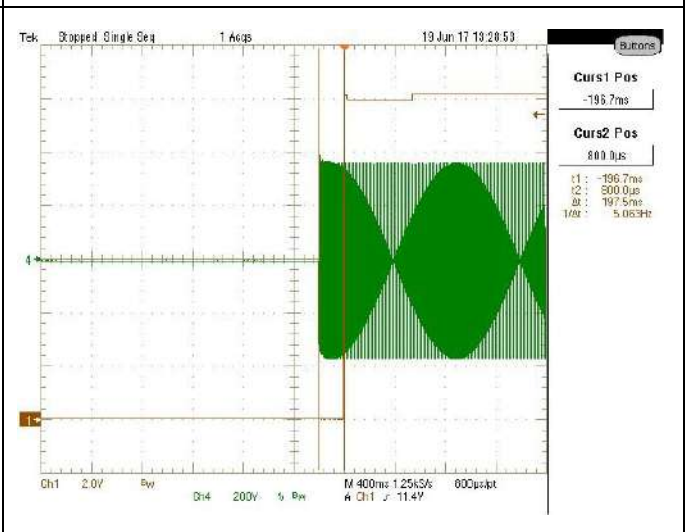

264Vac/63Hz-Max Load-Tsb_on_delay, CH1:12Vsb, CH4:Vin

+12V Turn On Delay Time						
Input Voltage (Vac)	Output		Limit (ms)		Test Result (ms)	Pass/Fail
	Voltage	Load(A)	Min	Max		
90.000	+12V	0.500	*	3000.000	2620.700	PASS
	+12Vaux	0.100				
90.000	+12V	65.000	*	3000.000	1722.300	PASS
	+12Vaux	2.000				
264.000	+12V	0.500	*	3000.000	879.100	PASS

	+12Vaux	0.100				
264.000	+12V	65.000	*	3000.000	943.100	PASS
	+12Vaux	2.000				

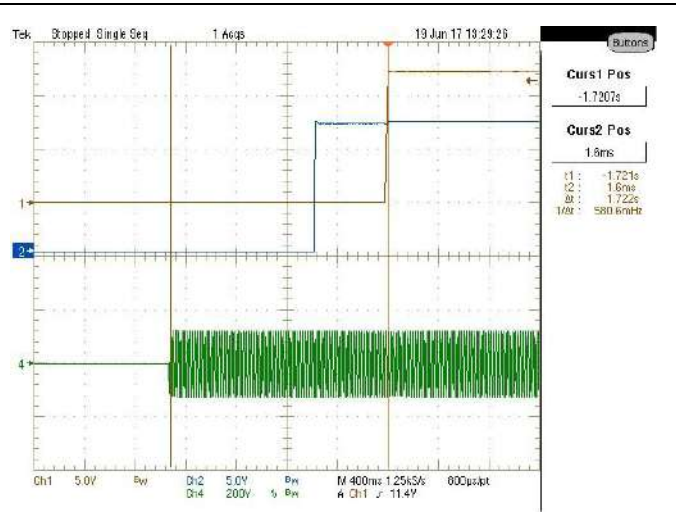
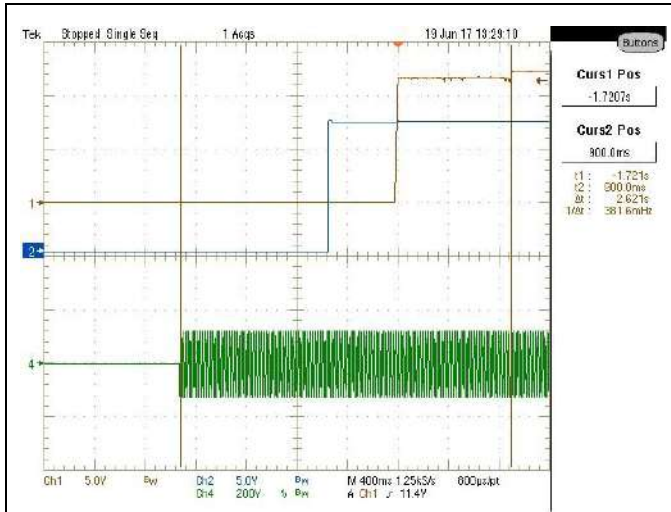

90Vac /47Hz-Min Load-T_ac_on_delay, CH1:12V ;
CH2:12Vaux ; CH4:Vin

90Vac /47Hz-Max Load-T_ac_on_delay, CH1:12V ;
CH2:12Vaux ; CH4:Vin

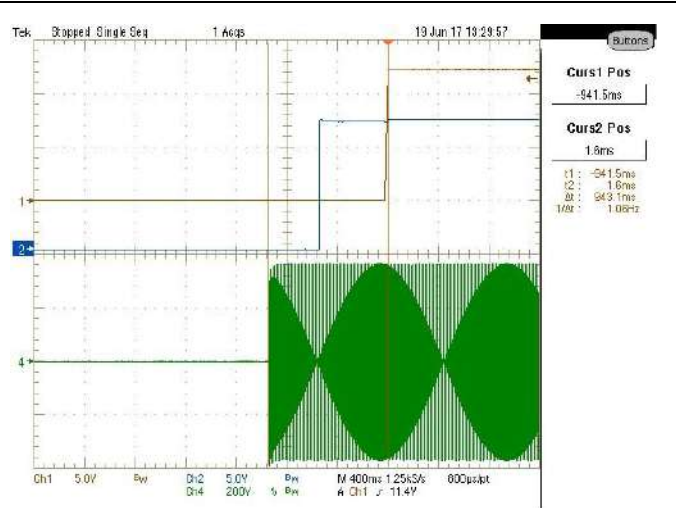
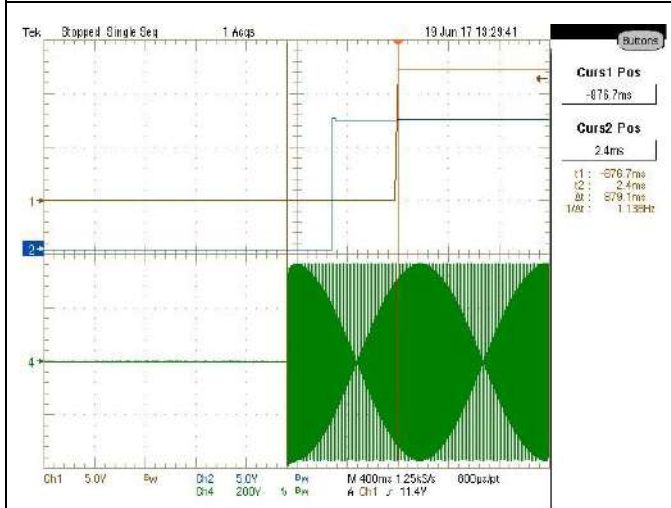

264Vac/63Hz-Min Load-T_ac_on_delay, CH1:12V ;
CH2:12Vaux ; CH4:Vin

264Vac/63Hz-Max Load-T_ac_on_delay,
CH1:12V ; CH2:12Vaux ; CH4:Vin

+12V Turn On To PWOK Delay Time						
Input Voltage (Vac)	Output		Limit (ms)		Test Result (ms)	Pass/Fail
	Voltage	Load(A)	Min	Max		
90.000	+12V	0.500	100.000	500.000	247.600	PASS
	+12Vaux	0.100				
90.000	+12V	65.000	100.000	500.000	247.600	PASS
	+12Vaux	2.000				
264.000	+12V	0.500	100.000	500.000	247.600	PASS
	+12Vaux	0.100				
264.000	+12V	65.000	100.000	500.000	247.600	PASS

	+12Vaux	2.000			
--	---------	-------	--	--	--

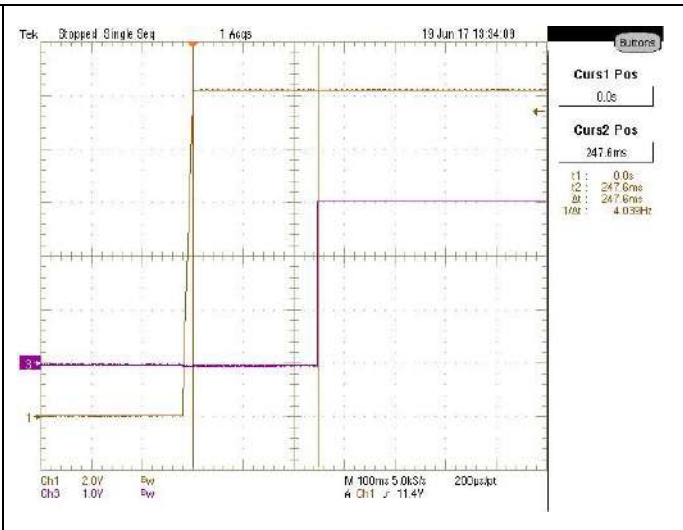
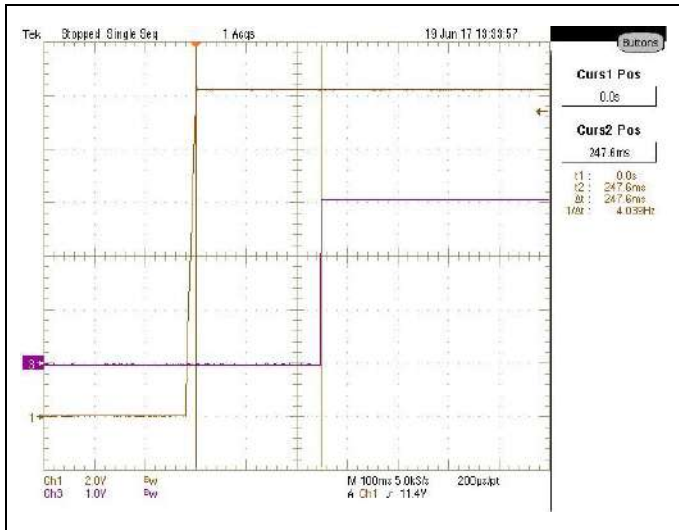

90Vac /47Hz-Min Load-Tpwok_on-,CH1:12V,
CH3:PWOK

90Vac /47Hz-Max Load-Tpwok_on-,CH1:12V,
CH3:PWOK

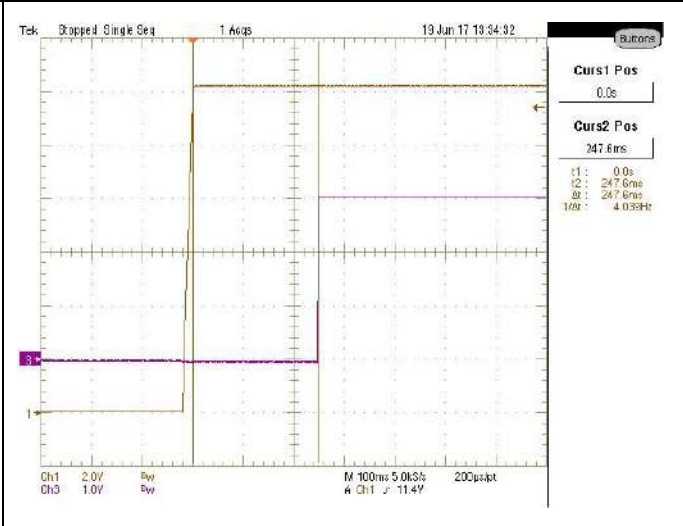
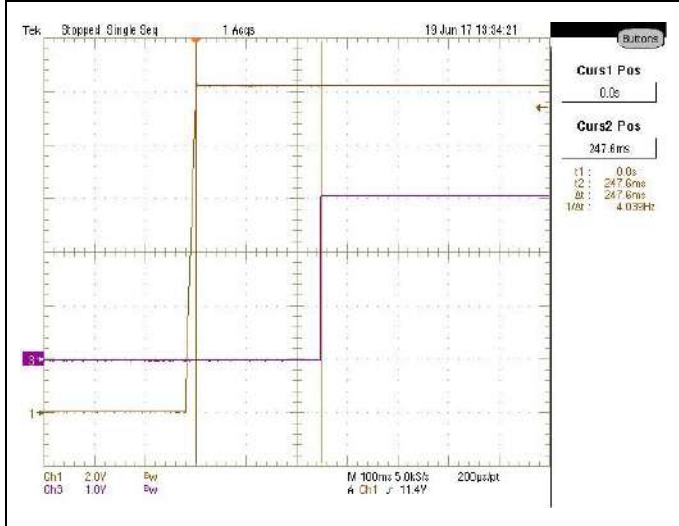

264Vac/63Hz-Min Load-Tpwok_on-,CH1:12V,
CH3:PWOK

264Vac/63Hz-Max Load-Tpwok_on-,CH1:12V,
CH3:PWOK

+12Vsb Turn On To +12V Delay Time

Input Voltage (Vac)	Output		Limit (ms)		Test Result (ms)	Pass/Fail
	Voltage	Load(A)	Min	Max		
90.000	+12V	0.500	50.000	1000.000	617.600	PASS
	+12Vaux	0.100				
90.000	+12V	65.000	50.000	1000.000	608.800	PASS
	+12Vaux	2.000				
264.000	+12V	0.500	50.000	1000.000	516.000	PASS
	+12Vaux	0.100				
264.000	+12V	65.000	50.000	1000.000	532.800	PASS
	+12Vaux	2.000				

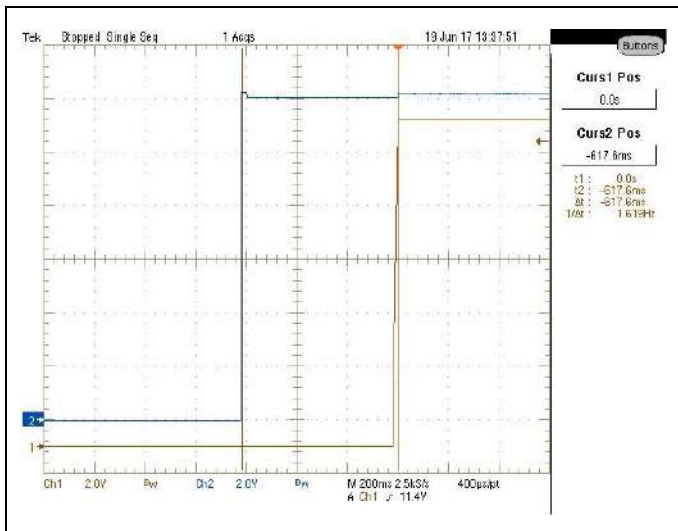

90Vac/47Hz-Min Load-Tsb_vout, CH1:12V,
CH2:12Vsb

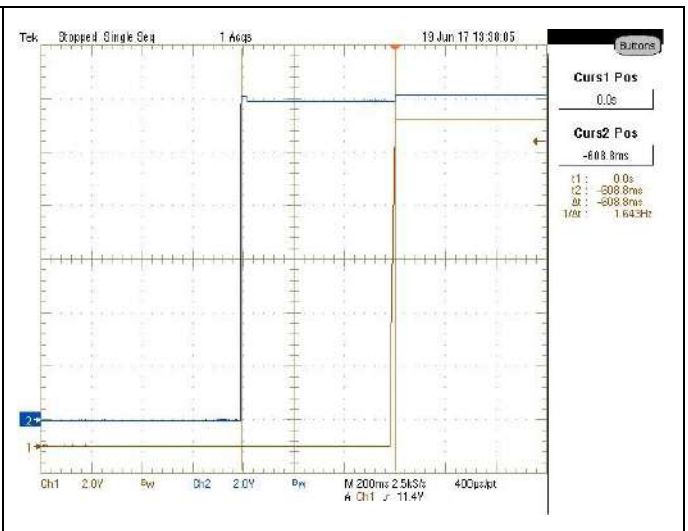

90Vac/47Hz-Max Load-Tsb_vout, CH1:12V,
CH2:12Vsb

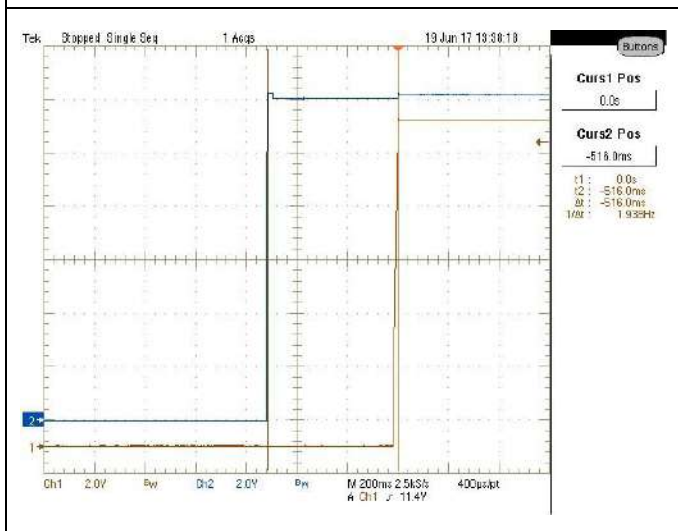

264Vac/63Hz-Min Load-Tsb_vout, CH1:12V,
CH2:12Vsb

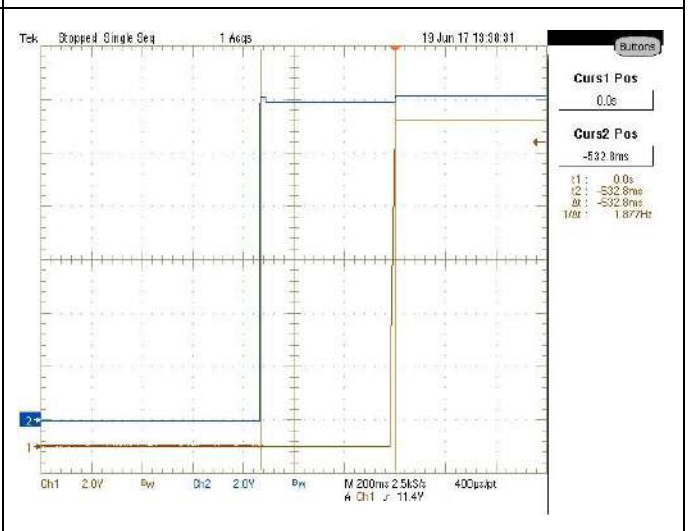

264Vac/63Hz-Max Load-Tsb_vout, CH1:12V,
CH2:12Vsb

+12V Hold Up Delay Time

Input Voltage (Vac)	Output		Limit (ms)		Test Result (ms)	Pass/Fail
	Voltage	Load(A)	Min	Max		
90.000	+12V	0.500	17.000	*	103.800	PASS
	+12Vaux	0.100				
90.000	+12V	52.000	17.000	*	27.820	PASS
	+12Vaux	1.600				
264.000	+12V	0.500	17.000	*	106.200	PASS
	+12Vaux	0.100				
264.000	+12V	52.000	17.000	*	24.520	PASS
	+12Vaux	1.600				

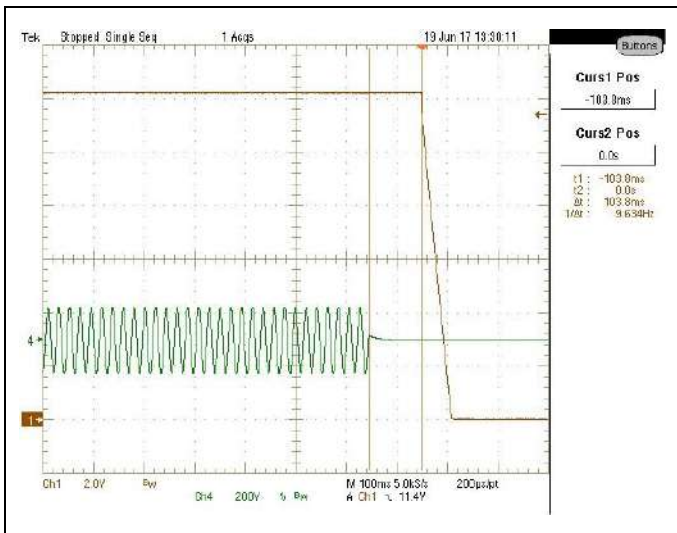

90Vac /47Hz-Min Load-Tvout_holdup, CH1:12V, CH4:Vin

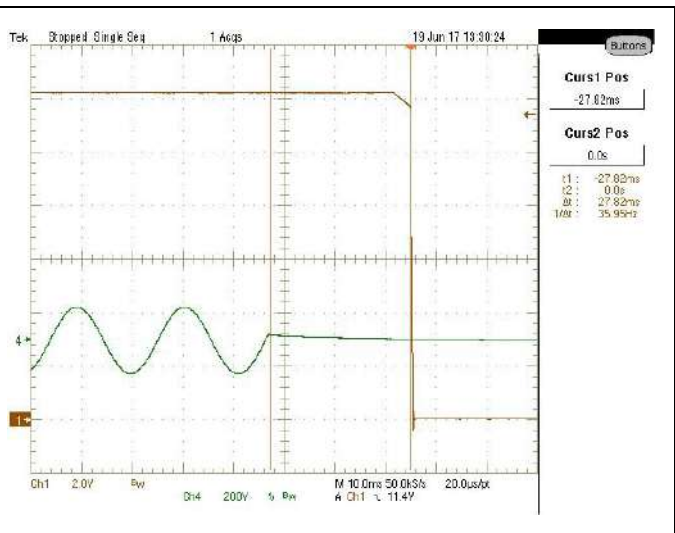

90V/47Hz-80% Load -Tvout_holdup, CH1:12V, CH4:Vin

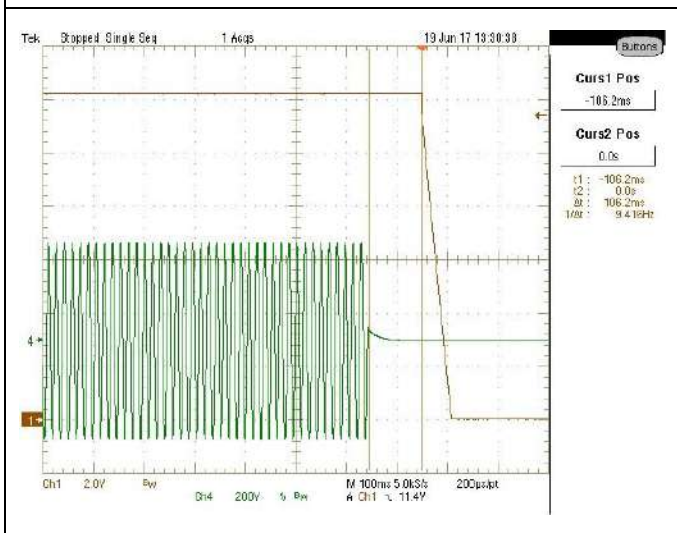

264Vac/63Hz-Min Load -Tvout_holdup, CH1:12V, CH4:Vin

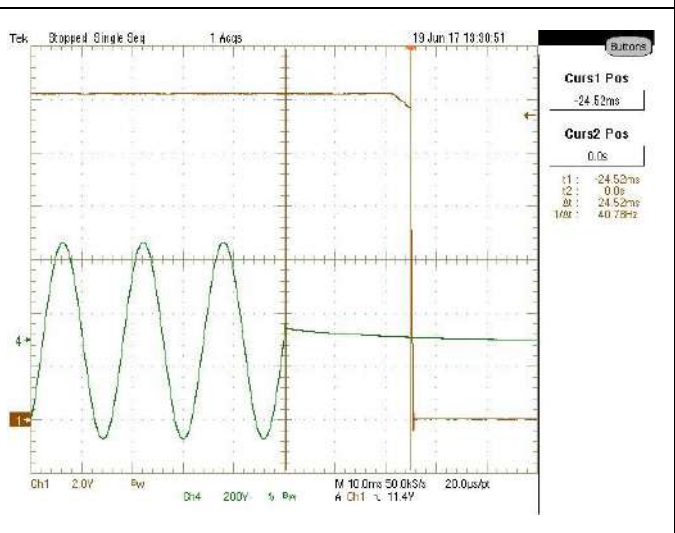

264Vac/63Hz-80% Load -Tvout_holdup, CH1:12V, CH4:Vin

+12Vsb Hold Up Delay Time

Input Voltage (Vac)	Output		Limit (ms)		Test Result (ms)	Pass/Fail
	Voltage	Load(A)	Min	Max		
90.000	+12V	0.500	70.000	*	189.000	PASS
	+12Vaux	0.100				
90.000	+12V	65.000	70.000	*	152.600	PASS
	+12Vaux	2.000				
264.000	+12V	0.500	70.000	*	499.800	PASS
	+12Vaux	0.100				
264.000	+12V	65.000	70.000	*	495.000	PASS
	+12Vaux	2.000				

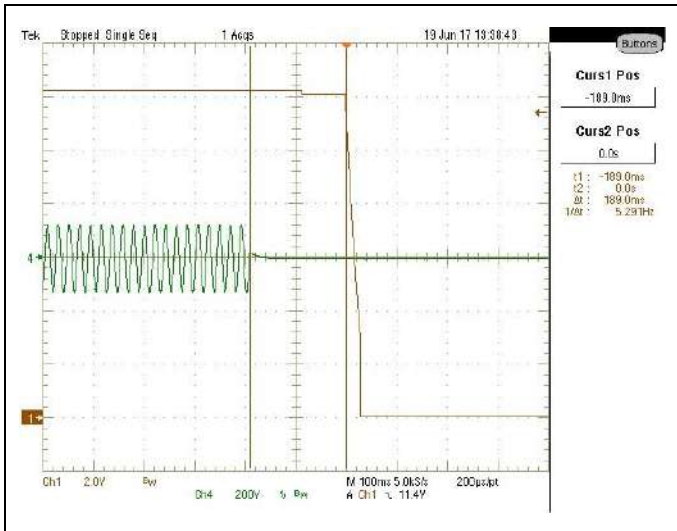

90V/47Hz-Min Load -T12VSB_holdup, CH1:12Vsb, CH4:Vin

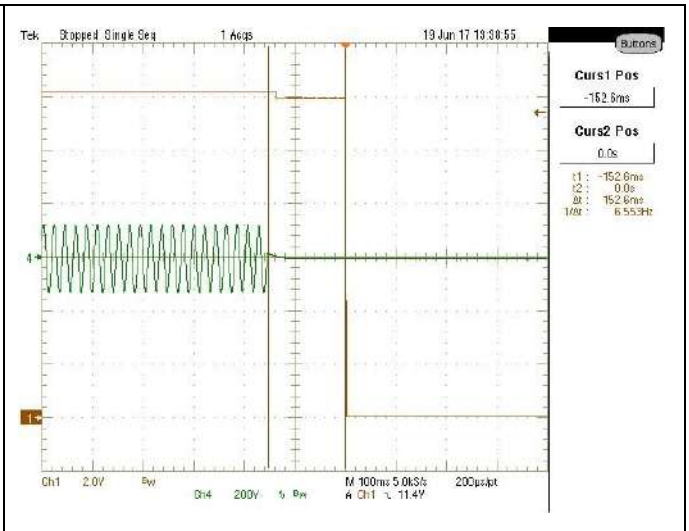

90V/47Hz-Max Load -T12VSB_holdup, CH1:12Vsb, CH4:Vin

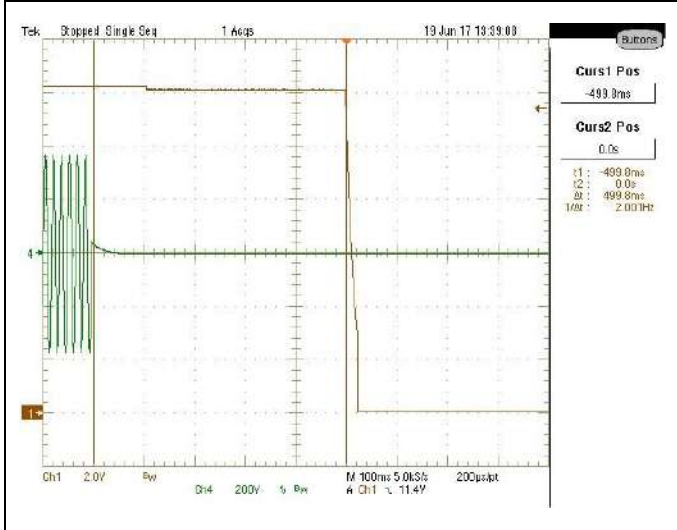

264Vac/63Hz-Min Load -T12VSB_holdup, CH1:12Vsb, CH4:Vin

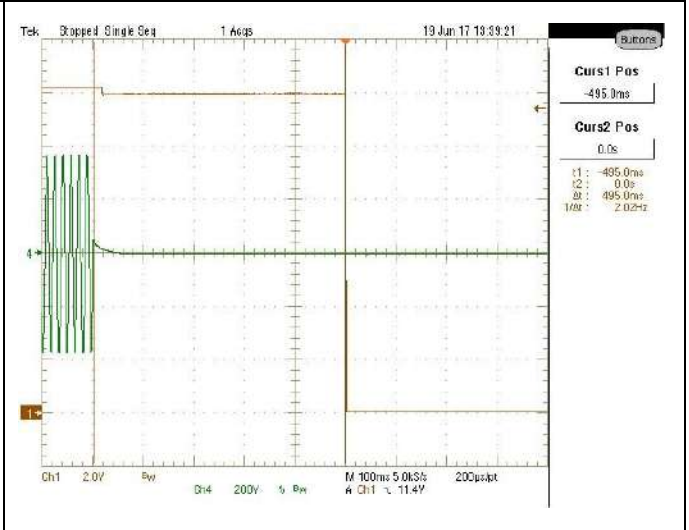

264Vac/63Hz-Max Load -T12VSB_holdup, CH1:12Vsb, CH4:Vin

PWOK Hold Up Delay Time

Input Voltage (Vac)	Output		Limit (ms)		Test Result (ms)	Pass/Fail
	Voltage	Load(A)	Min	Max		
90.000	+12V	0.500	16.000	*	102.000	PASS
	+12Vaux	0.100				
90.000	+12V	52.000	16.000	*	25.840	PASS
	+12Vaux	1.600				
264.000	+12V	0.500	16.000	*	104.600	PASS
	+12Vaux	0.100				
264.000	+12V	52.000	16.000	*	23.340	PASS
	+12Vaux	1.600				

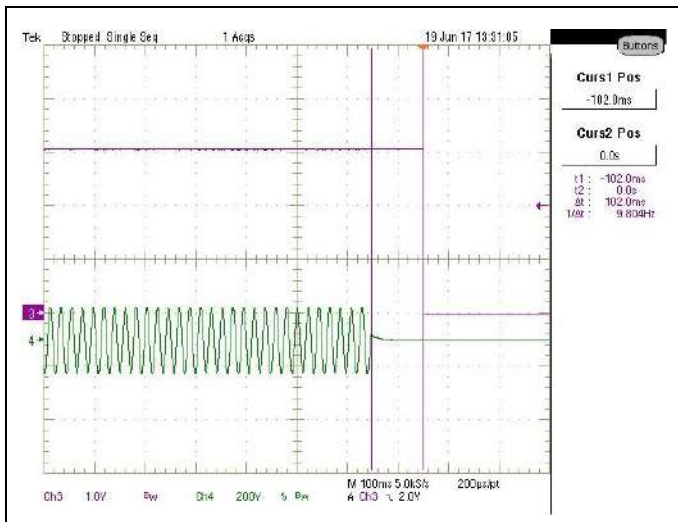

90V/47hz-Min Load-Tpwok_holdup, CH3:PWOK, CH4:Vin

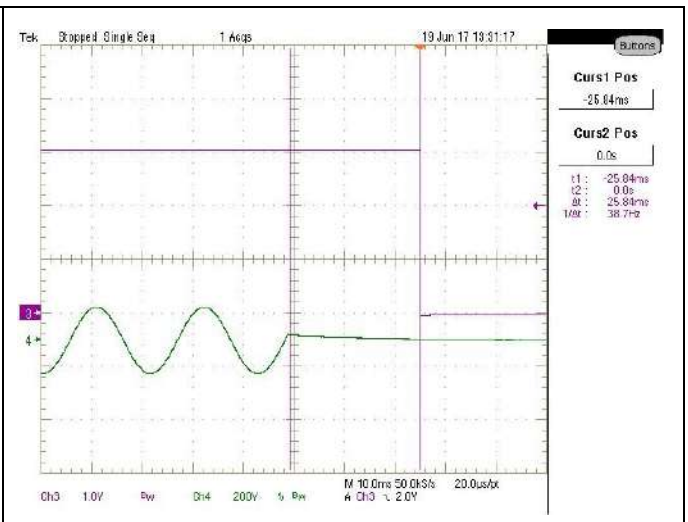

90V/47hz-80% Load-Tpwok_holdup, CH3:PWOK, CH4:Vin

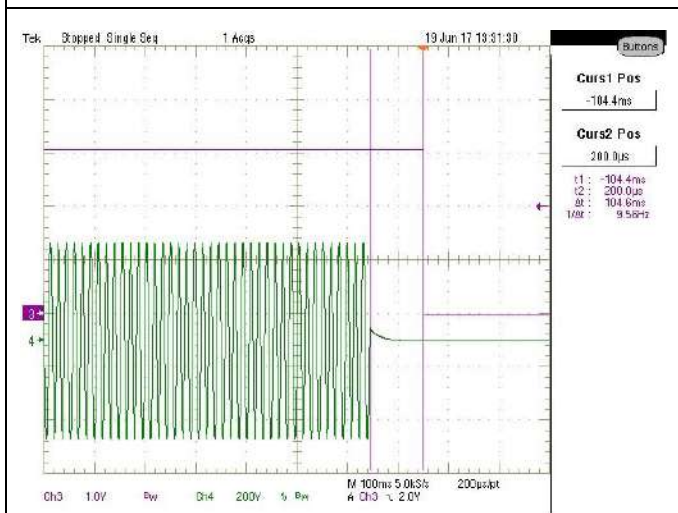

264Vac/63Hz-Min Load-Tpwok_holdup, CH3:PWOK, CH4:Vin

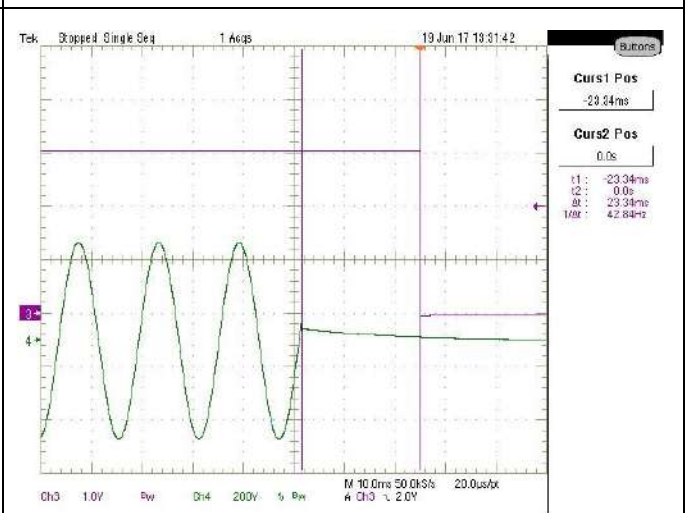

264Vac/63Hz-80% Load-Tpwok_holdup, CH3:PWOK, CH4:Vin

PWOK Turn Off To +12V Delay Time

Input Voltage (Vac)	Output		Limit (ms)		Test Result (ms)	Pass/Fail
	Voltage	Load(A)	Min	Max		
90.000	+12V	0.500	1.000	*	2.296	PASS
	+12Vaux	0.100				
90.000	+12V	65.000	1.000	*	1.480	PASS
	+12Vaux	2.000				
264.000	+12V	0.500	1.000	*	2.232	PASS
	+12Vaux	0.100				
264.000	+12V	65.000	1.000	*	1.504	PASS
	+12Vaux	2.000				

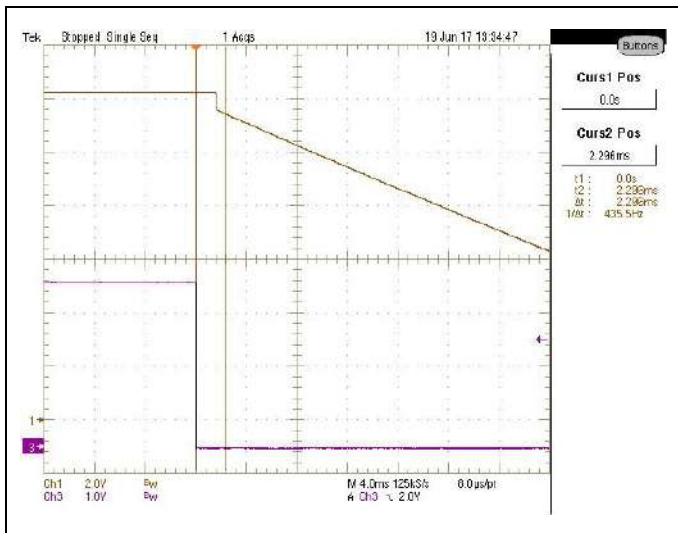

90Vac/47Hz-Min Load-Tpwok_off, CH1:12V,
CH2:PWOK

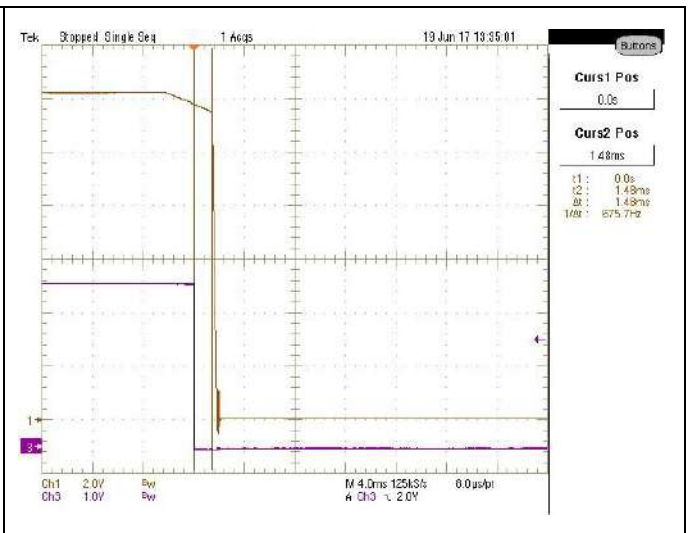

90Vac/47Hz-Max Load-Tpwok_off, CH1:12V,
CH2:PWOK

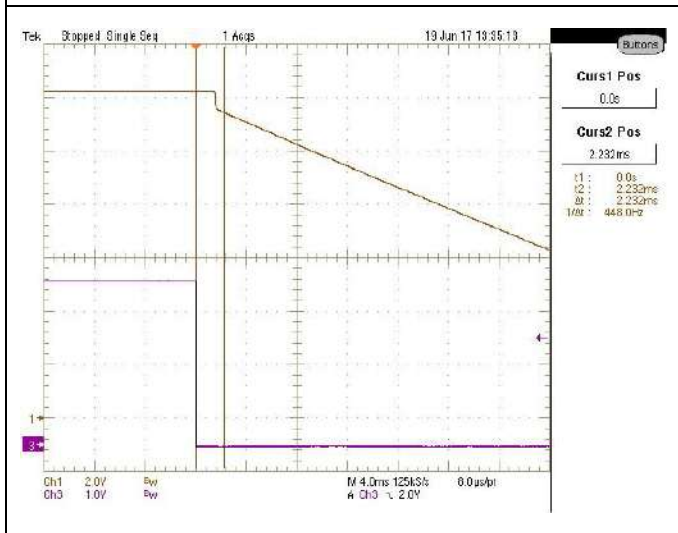

264Vac/63Hz-Min Load-Tpwok_off, CH1:12V,
CH2:PWOK



264Vac/63Hz-Max Load-Tpwok_off, CH1:12V,
CH2:PWOK

PSON activate To +12V Delay Time

Input Voltage (Vac)	Output		Limit (ms)		Test Result (ms)	Pass/Fail
	Voltage	Load(A)	Min	Max		
90.000	+12V	0.500	5.000	400.000	224.600	PASS
	+12Vaux	0.100				
90.000	+12V	65.000	5.000	400.000	224.600	PASS
	+12Vaux	2.000				
264.000	+12V	0.500	5.000	400.000	225.000	PASS
	+12Vaux	0.100				
264.000	+12V	65.000	5.000	400.000	225.000	PASS
	+12Vaux	2.000				

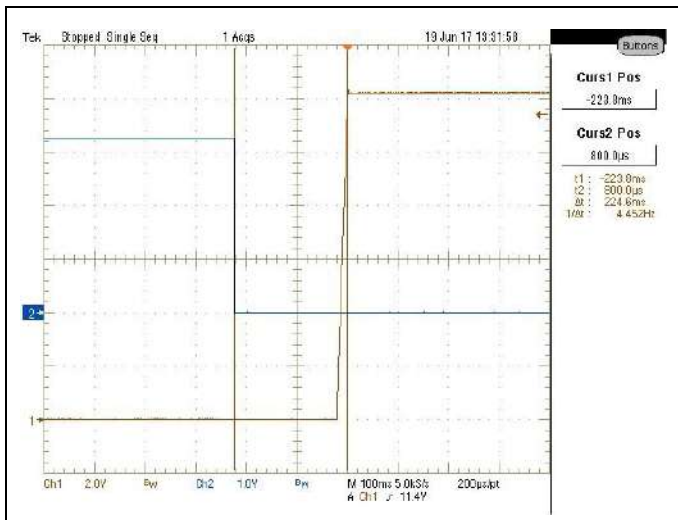

90Vac/47Hz-Min Load-Tpson_on_delay, CH1:12V, CH2:PSON

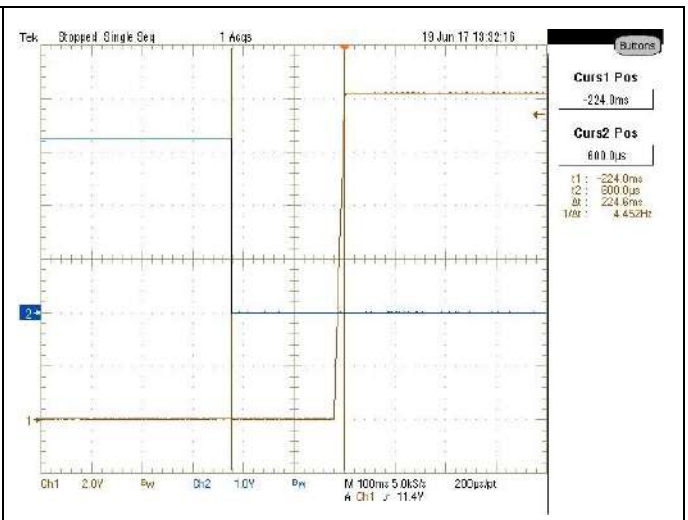

90Vac/47Hz-Max Load-Tpson_on_delay, CH1:12V, CH2:PSON

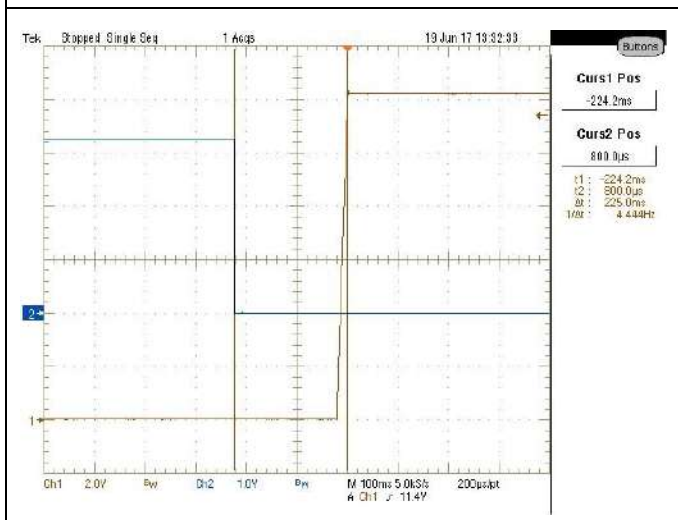

264Vac/63Hz-Min Load-Tpson_on_delay, CH1:12V, CH2:PSON

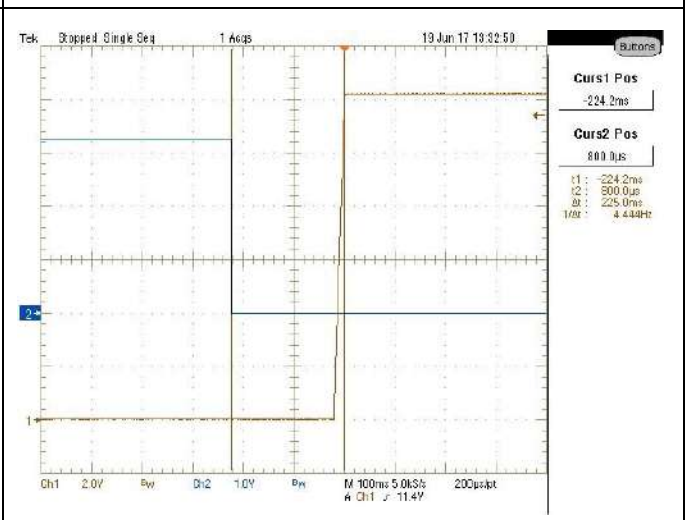

264Vac/63Hz-Max Load-Tpson_on_delay, CH1:12V, CH2:PSON

PSON Deactivate To PWOK Delay Time

Input Voltage (Vac)	Output		Limit (ms)		Test Result (ms)	Pass/Fail
	Voltage	Load(A)	Min	Max		
90.000	+12V	0.500	*	5.000	1.732	PASS
	+12Vaux	0.100				
90.000	+12V	65.000	*	5.000	1.550	PASS
	+12Vaux	2.000				
264.000	+12V	0.500	*	5.000	1.450	PASS
	+12Vaux	0.100				
264.000	+12V	65.000	*	5.000	1.434	PASS
	+12Vaux	2.000				

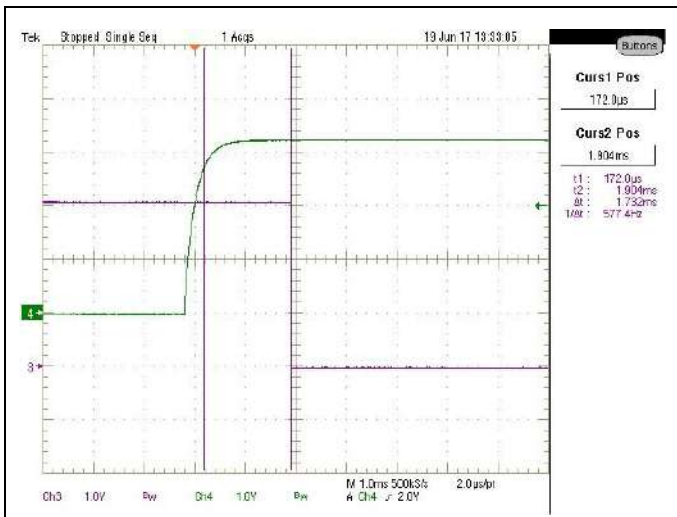

90V/47Hz-Min Load-Tpson_pwok, CH3:PWOK, CH4:PSON

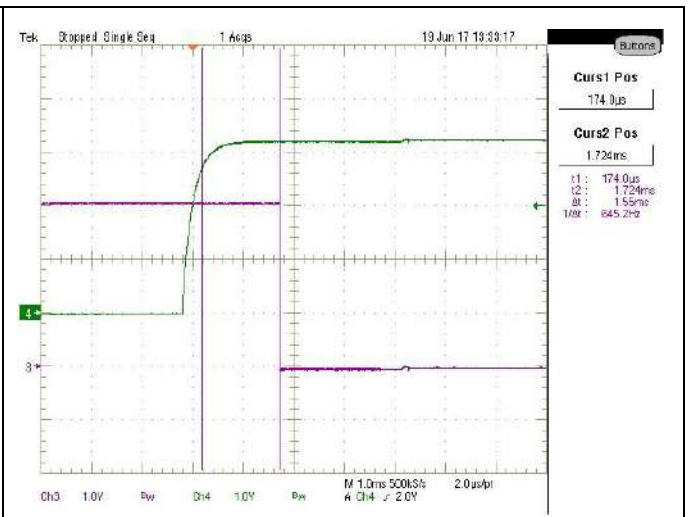

90V/47Hz-Max Load-Tpson_pwok, CH3:PWOK, CH4:PSON

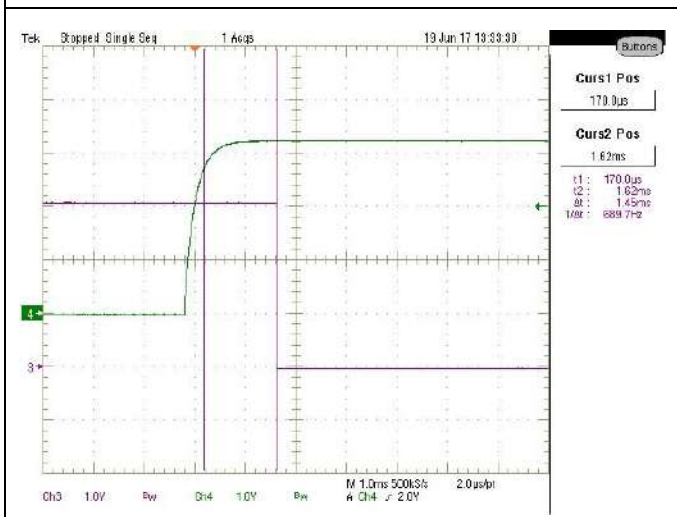

264Vac/63Hz-Min Load-Tpson_pwok, CH3:PWOK, CH4:PSON



264Vac/63Hz-Max Load-Tpson_pwok, CH3:PWOK, CH4:PSON

PWOK Recovery Delay Time by AC

Input Voltage (Vac)	Drop time (mS)	Output		Limit (ms)		Test Result (ms)	Pass/Fail
		Voltage	Load(A)	Min	Max		
90.000	200	+12V	0.500	100.000	*	1529.600	PASS
		+12Vaux	0.100				
90.000	50	+12V	65.000	100.000	*	1929.600	PASS
		+12Vaux	2.000				
264.000	500	+12V	0.500	100.000	*	1133.600	PASS
		+12Vaux	0.100				
264.000	50	+12V	65.000	100.000	*	1248.800	PASS
		+12Vaux	2.000				

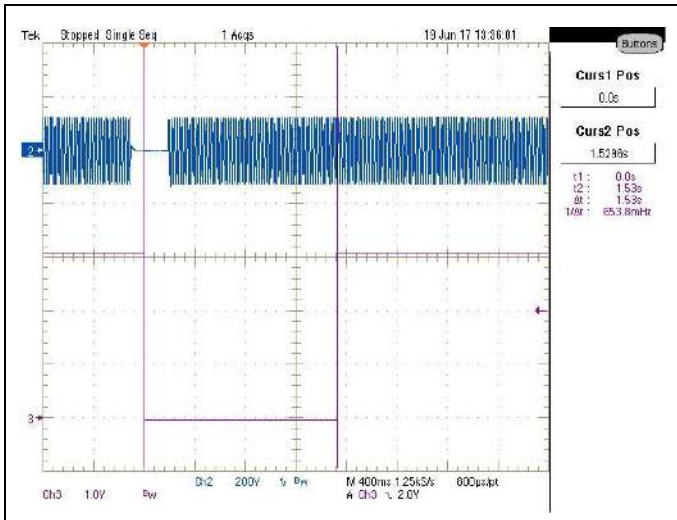

90Vac/47Hz-Min Load-Tpwok_low, CH2:;Vin,
CH3:PWOK

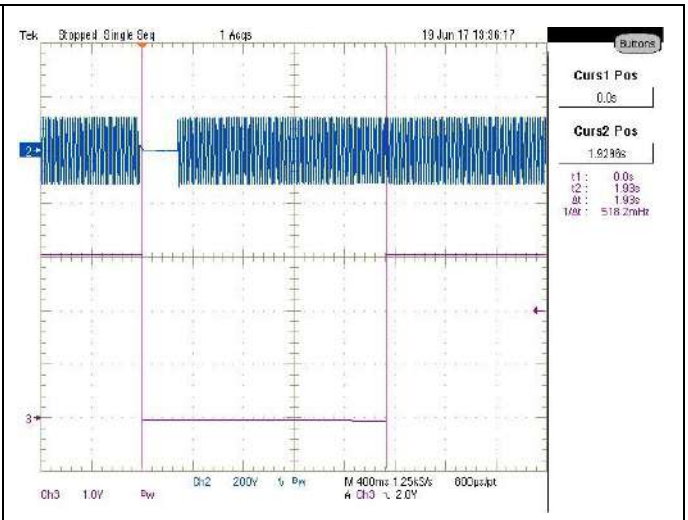

90Vac/47Hz-Max Load-Tpwok_low, CH2:;Vin,
CH3:PWOK

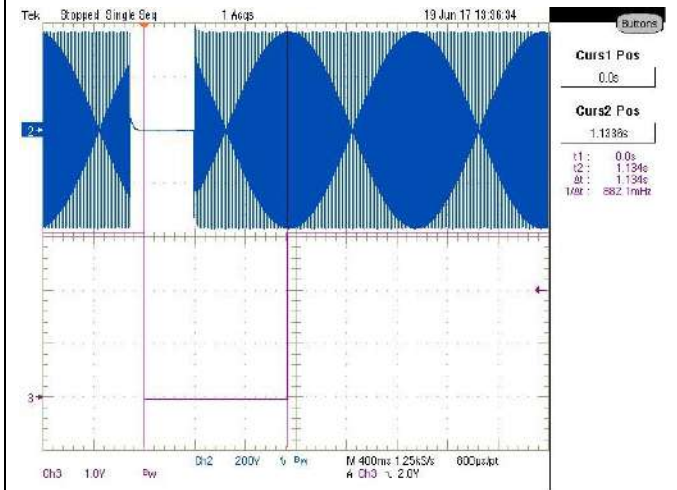

264Vac/63Hz-Min Load-Tpwok_low, CH2:;Vin,
CH3:PWOK

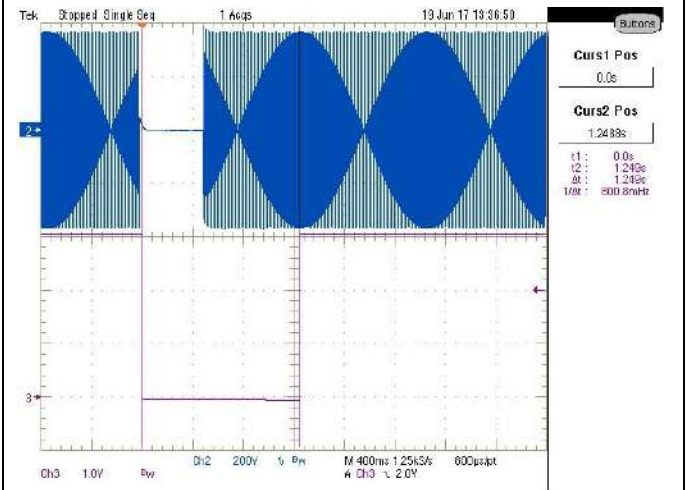

264Vac/63Hz-Max Load-Tpwok_low, CH2:;Vin,
CH3:PWOK

PWOK Recovery Delay Time by PSON

Input Voltage (Vac)	PSON# deactivate time duration (mS)	Output		Limit (ms)		Test Result (ms)	Pass/Fail
		Voltage	Load(A)	Min	Max		
90.000	50.000	+12V	0.500	100.000	*	529.200	PASS
		+12Vaux	0.100				
90.000	50.000	+12V	65.000	100.000	*	520.000	PASS
		+12Vaux	2.000				
264.000	50.000	+12V	0.500	100.000	*	529.600	PASS
		+12Vaux	0.100				
264.000	50.000	+12V	65.000	100.000	*	519.200	PASS
		+12Vaux	2.000				



90Vac/47Hz-Min Load-Tpwok_low, CH2:,PSN, CH3:PWOK

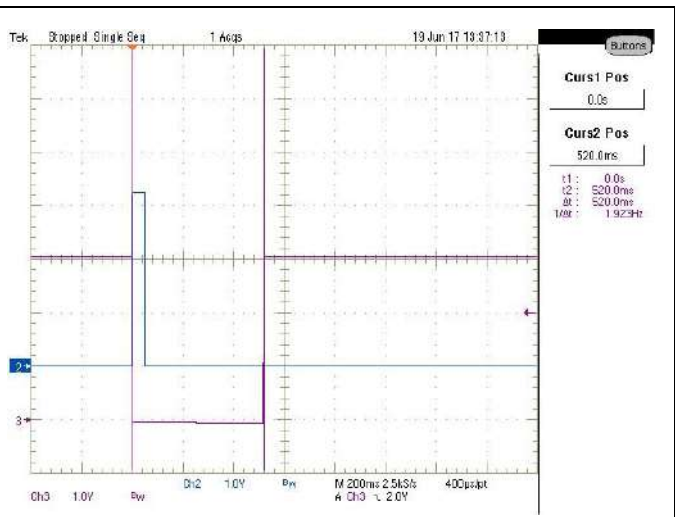

90Vac/47Hz-Max Load-Tpwok_low, CH2:,PSN, CH3:PWOK

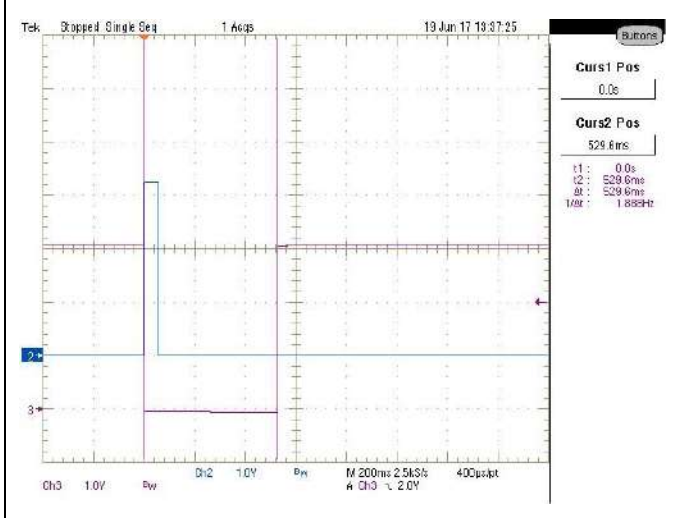

264Vac/63Hz-Min Load-Tpwok_low, CH2:,PSN, CH3:PWOK

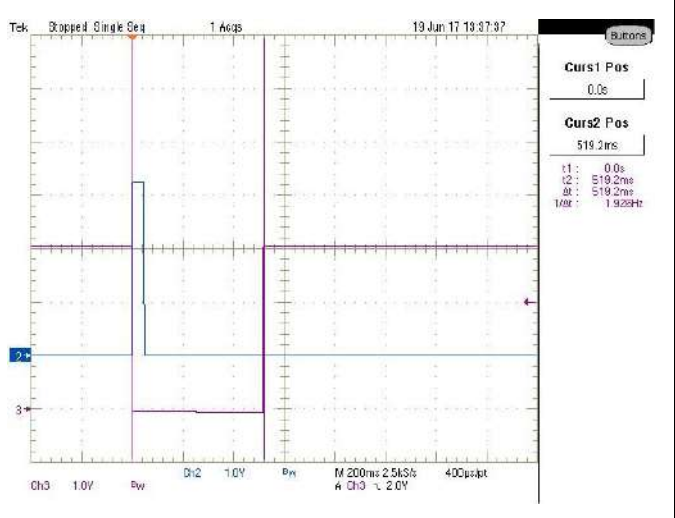

264Vac/63Hz-Max Load-Tpwok_low, CH2:,PSN, CH3:PWOK

PWOK Rise time						
Input Voltage (Vac)	Output		Limit (ms)		Test Result (mS)	Pass/Fail
	Voltage	Load(A)	Min	Max		
90.000	+12V	0.500	*	0.100	0.0004	PASS
	+12Vaux	0.100				
90.000	+12V	65.000	*	0.100	0.0004	PASS
	+12Vaux	2.000				
264.000	+12V	0.500	*	0.100	0.0004	PASS
	+12Vaux	0.100				
264.000	+12V	65.000	*	0.100	0.0004	PASS
	+12Vaux	2.000				

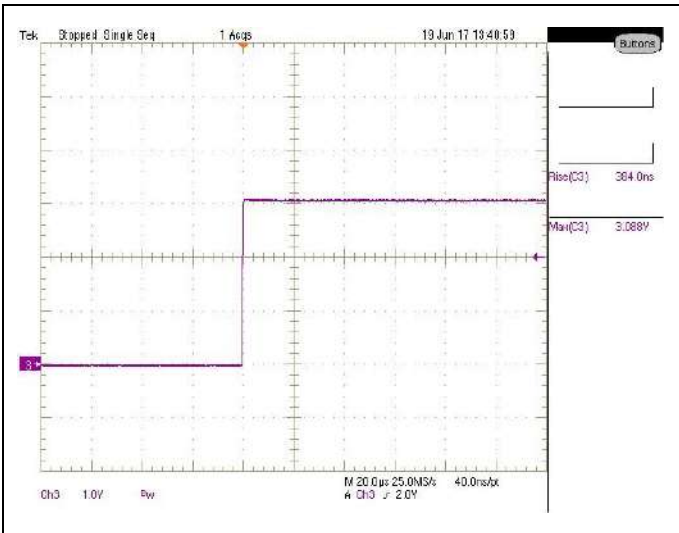

90Vac/47Hz-Min Load-PWOK Rise_Time, CH3:PWOK

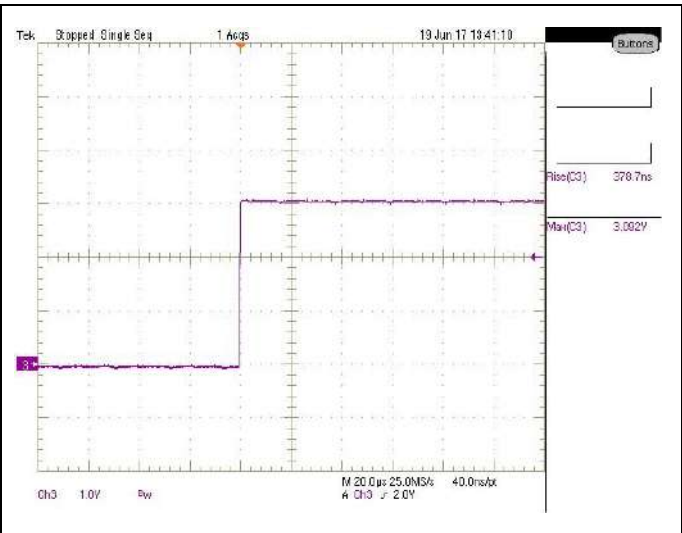

90Vac/47Hz-Max Load-PWOK Rise_Time, CH3:PWOK

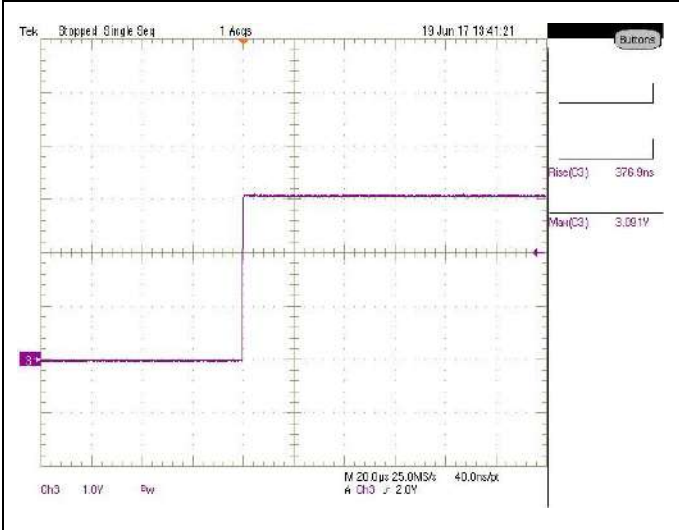

264Vac/63Hz-Min Load-PWOK Rise_Time, CH3:PWOK

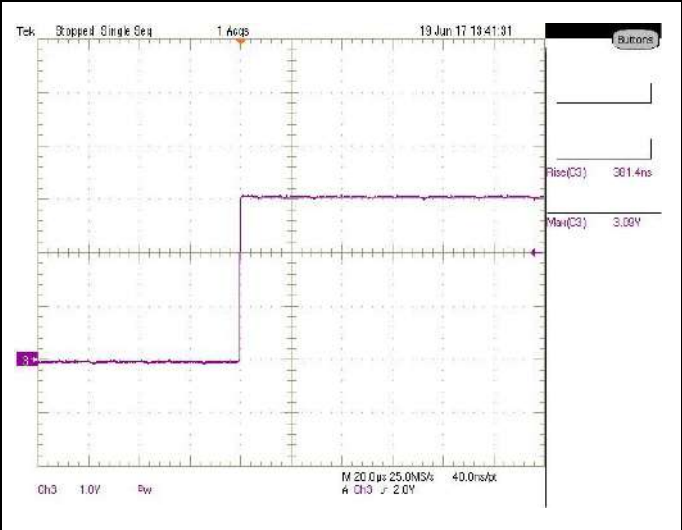

264Vac/63Hz-Max Load-PWOK Rise_Time, CH3:PWOK

PWOK Fall time						
Input Voltage (Vac)	Output		Limit (ms)		Test Result (mS)	Pass/Fail
	Voltage	Load(A)	Min	Max		
90.000	+12V	0.500	*	0.100	0.0007	PASS
	+12Vaux	0.100				
90.000	+12V	65.000	*	0.100	0.0007	PASS
	+12Vaux	2.000				
264.000	+12V	0.500	*	0.100	0.0007	PASS
	+12Vaux	0.100				
264.000	+12V	65.000	*	0.100	0.0007	PASS
	+12Vaux	2.000				

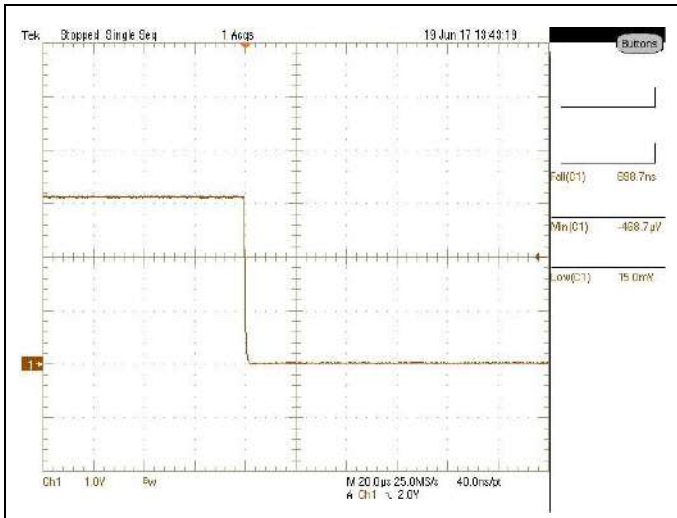

90Vac/47Hz-Min Load-PWOK Fall Time, CH1:PWOK

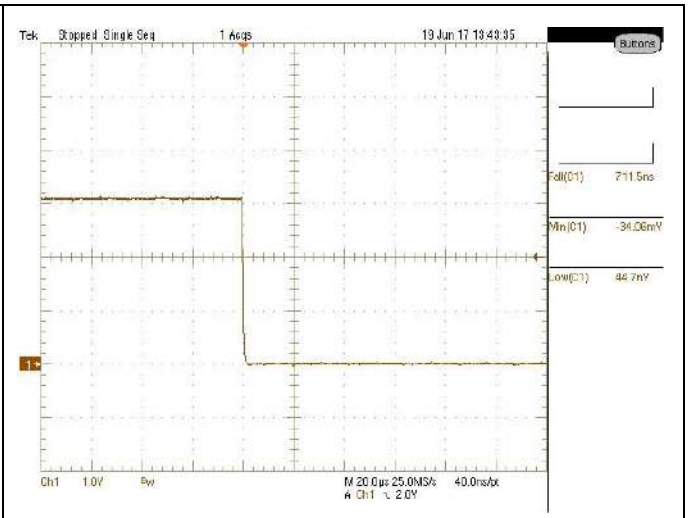

90Vac/47Hz-Max Load-PWOK Fall Time, CH1:PWOK

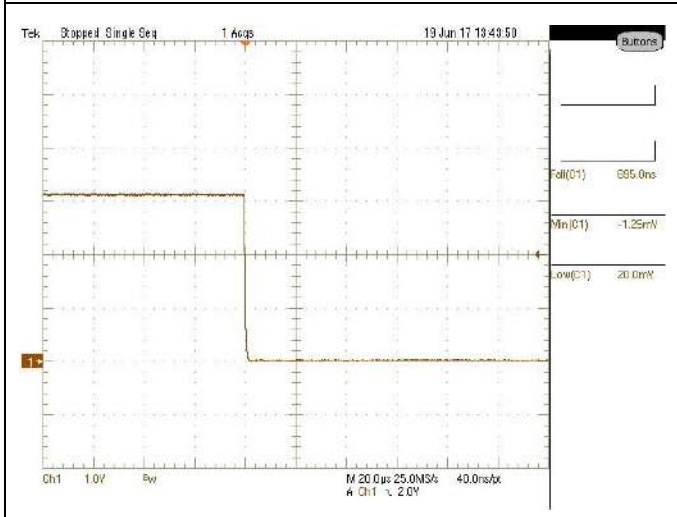

264Vac/63Hz-Min Load-PWOK Fall Time, CH1:PWOK

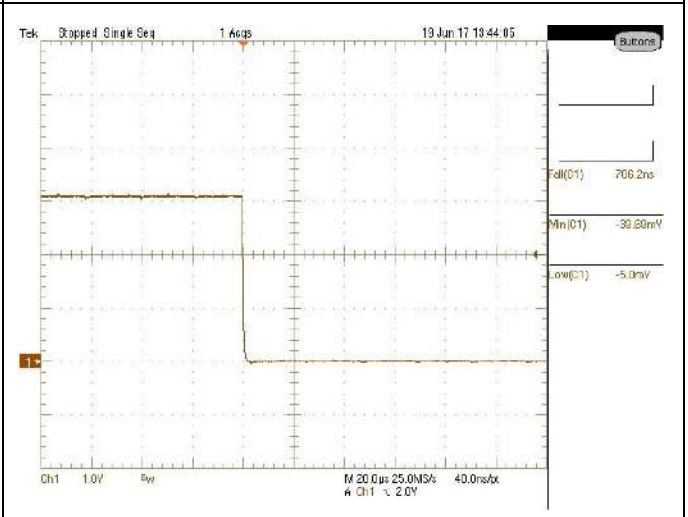

264Vac/63Hz-Max Load-PWOK Fall Time, CH1:PWOK

Alert# Rise time						
Input Voltage (Vac)	Output		Limit(mS)		Test Result (mS)	Pass/Fail
	Voltage	Load(A)	Min	Max		
90	+12V	0.500	*	0.100	0.0009	PASS
	+12Vaux	0.100				
90	+12V	65.000	*	0.100	0.0009	PASS
	+12Vaux	2.000				
264	+12V	0.500	*	0.100	0.0009	PASS
	+12Vaux	0.100				
264	+12V	65.000	*	0.100	0.0009	PASS
	+12Vaux	2.000				

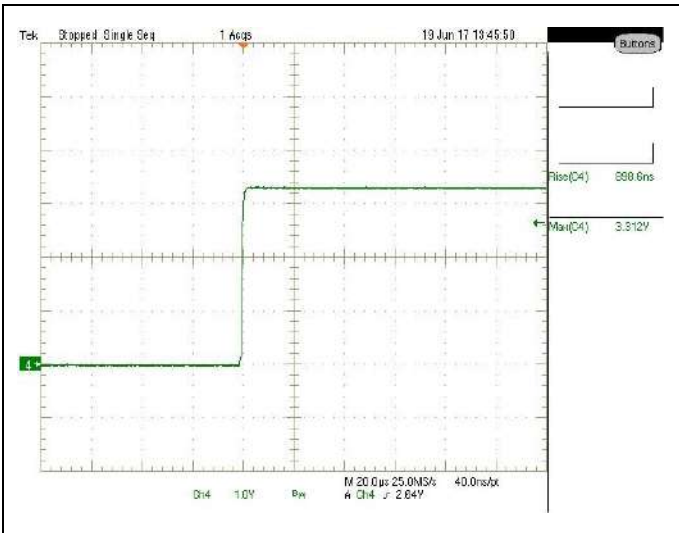

90Vac/47Hz-Min Load-Alert# Rise_Time, CH4:Alert#

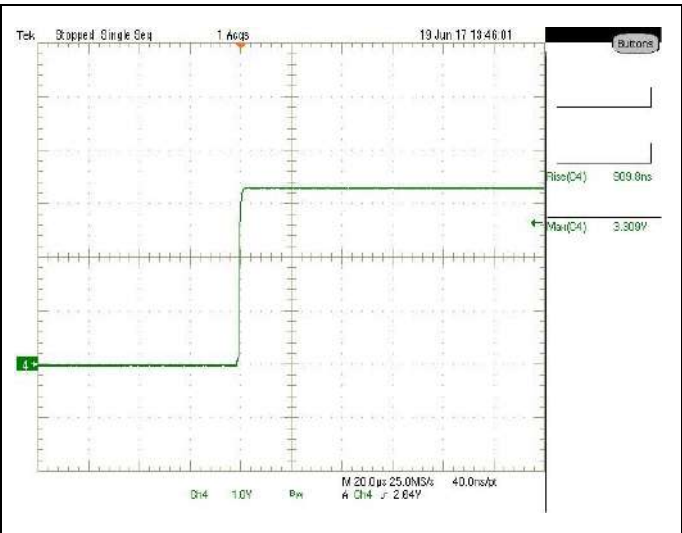

90Vac/47Hz-Max Load-Alert# Rise_Time, CH4:Alert#

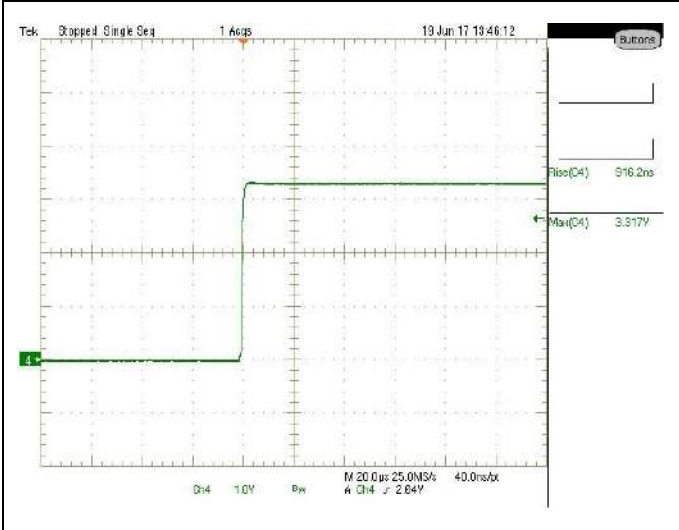

264Vac/63Hz-Min Load-Alert# Rise_Time, CH4:Alert#

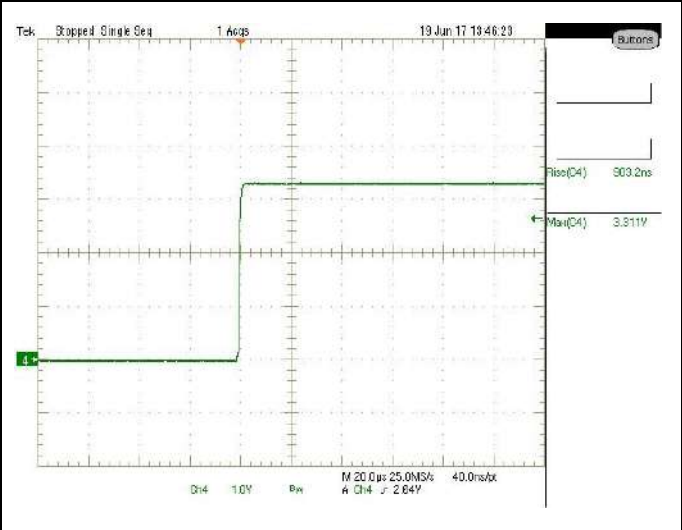

264Vac/63Hz-Max Load-Alert# Rise_Time, CH4:Alert#

Alert# Fall time						
Input Voltage (Vac)	Output		Limit(mS)		Test Result (mS)	Pass/Fail
	Voltage	Load(A)	Min	Max		
90	+12V	0.500	*	0.100	0.0003	PASS
	+12Vaux	0.100				
90	+12V	65.000	*	0.100	0.0003	PASS
	+12Vaux	2.000				
264	+12V	0.500	*	0.100	0.0003	PASS
	+12Vaux	0.100				
264	+12V	65.000	*	0.100	0.0003	PASS
	+12Vaux	2.000				

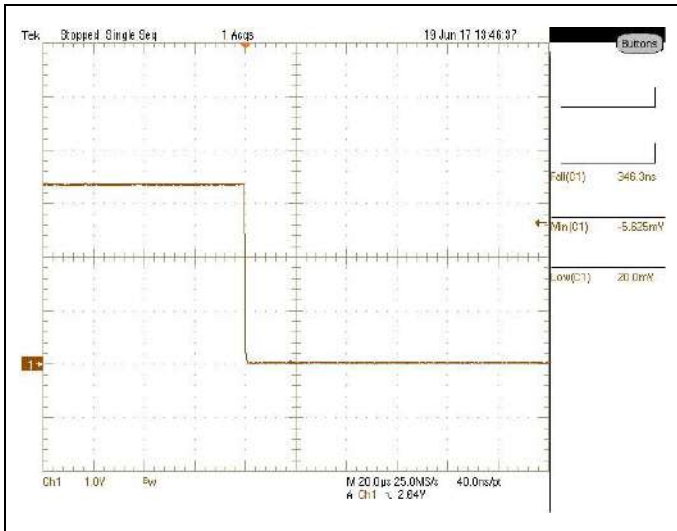

90Vac/47Hz-Min Load-Alert# Fall Time, CH4:Alert#

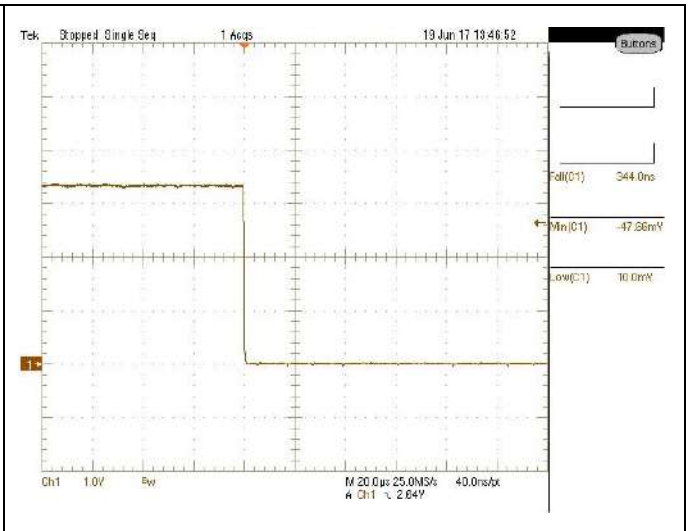

90Vac/47Hz-Max Load-Alert# Fall Time, CH4:Alert#

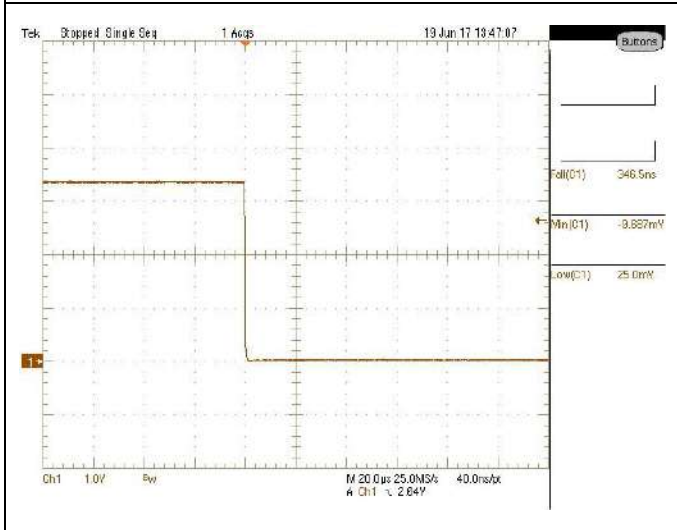

264Vac/63Hz-Min Load-Alert# Fall Time, CH4:Alert#

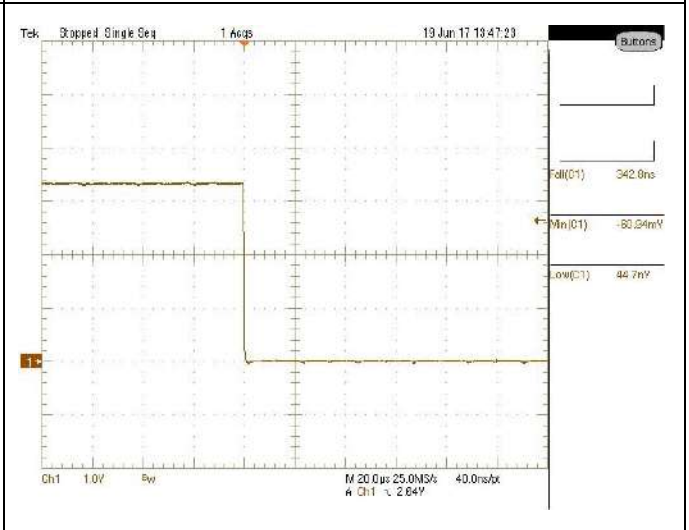

264Vac/63Hz-Max Load-Alert# Fall Time, CH4:Alert#

Error-Free Operation

Input Voltage (Vac)	Output		Limit		Test Result		Pass / Fail	Fig No
	Voltage	Load	Min	Max	Vpk_low	Vpk_high		
100V-25% 2 Sec min	+12V	0.500	11.400	12.600	>11.400	<12.600	PASS	1
	+12Vaux	0.100	11.400	12.600				
100V-25% 2 Sec max	+12V	65.000	11.400	12.600	>11.400	<12.600	PASS	2
	+12Vaux	2.000	11.400	12.600				
100V-32% 0.5 Sec min	+12V	0.500	11.400	12.600	>11.400	<12.600	PASS	3
	+12Vaux	0.100	11.400	12.600				
100V-32% 0.5 Sec max	+12V	65.000	11.400	12.600	>11.400	<12.600	PASS	4
	+12Vaux	2.000	11.400	12.600				
100V-100% 16ms min	+12V	0.500	11.400	12.600	>11.400	<12.600	PASS	5
	+12Vaux	0.100	11.400	12.600				
100V-100% 16ms 80%	+12V	52.000	11.400	12.600	>11.400	<12.600	PASS	6
	+12Vaux	1.600	11.400	12.600				

Load								
200V-25% 2 Sec min	+12V	0.500	11.400	12.600	>11.400	<12.600	PASS	7
	+12Vaux	0.100	11.400	12.600				
200V-25% 2 Sec max	+12V	65.000	11.400	12.600	>11.400	<12.600	PASS	8
	+12Vaux	2.000	11.400	12.600				
200V-32% 0.5 Sec min	+12V	0.500	11.400	12.600	>11.400	<12.600	PASS	9
	+12Vaux	0.100	11.400	12.600				
200V-32% 0.5 Sec max	+12V	65.000	11.400	12.600	>11.400	<12.600	PASS	10
	+12Vaux	2.000	11.400	12.600				
200V-100% 16ms min	+12V	0.500	11.400	12.600	>11.400	<12.600	PASS	11
	+12Vaux	0.100	11.400	12.600				
200V-100% 16ms 80% Load	+12V	52.000	11.400	12.600	>11.400	<12.600	PASS	12
	+12Vaux	1.600	11.400	12.600				

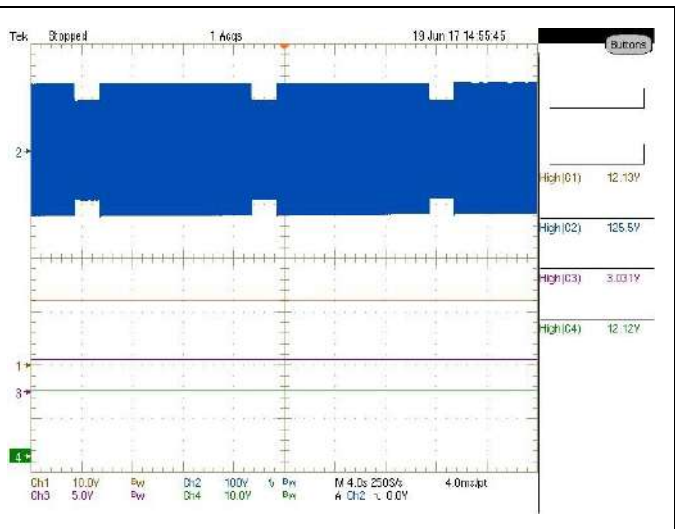
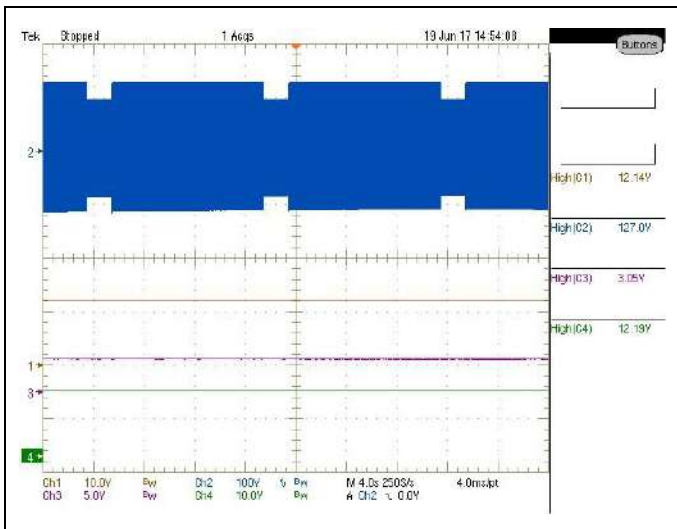

100V-25% 2 Sec min

Fig: 1

100V-25% 2 Sec max

Fig: 2

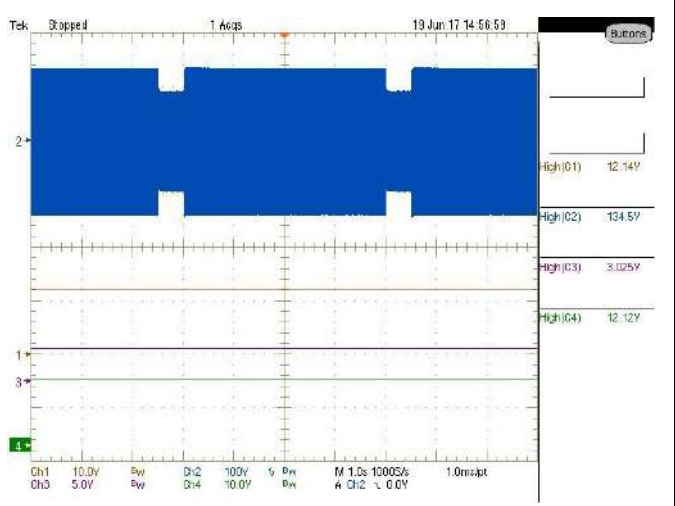
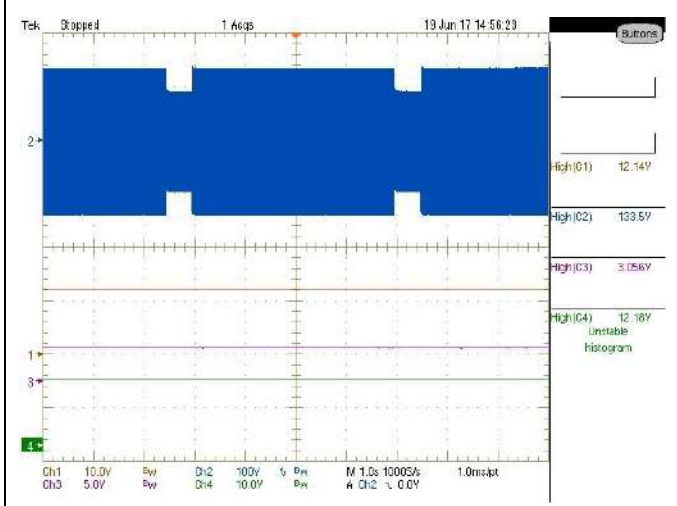

100V-32% 0.5 Sec min

Fig: 3

100V-32% 0.5 Sec max

Fig: 4

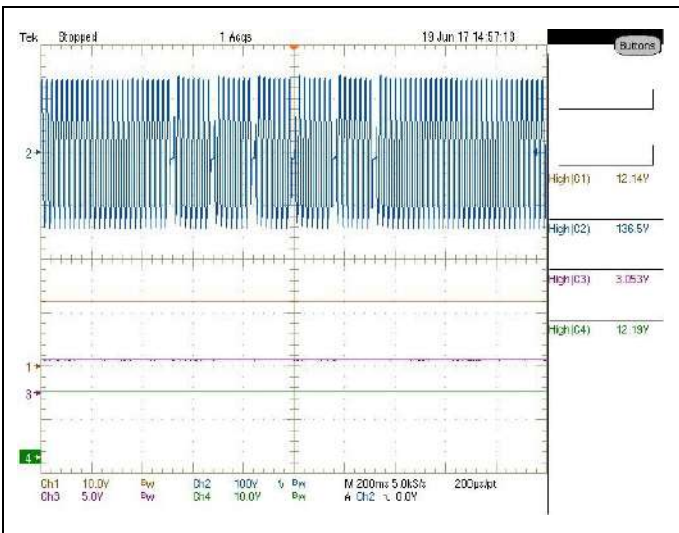

100V-100% 16ms min

Fig: 5

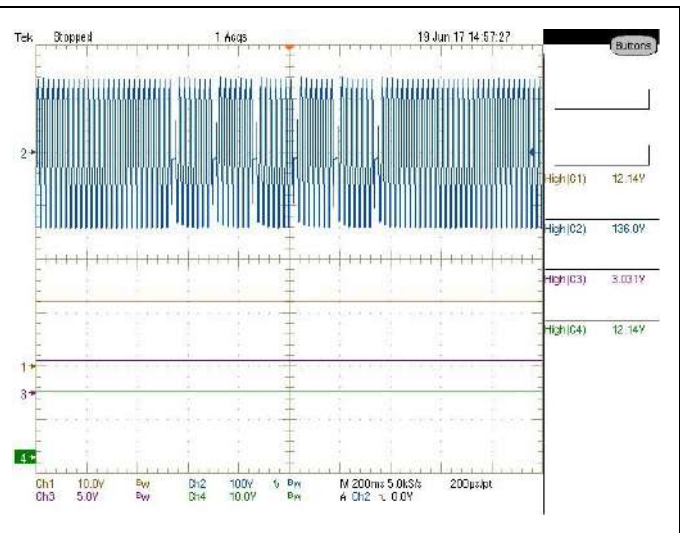

100V-100% 16ms 80% Load

Fig: 6

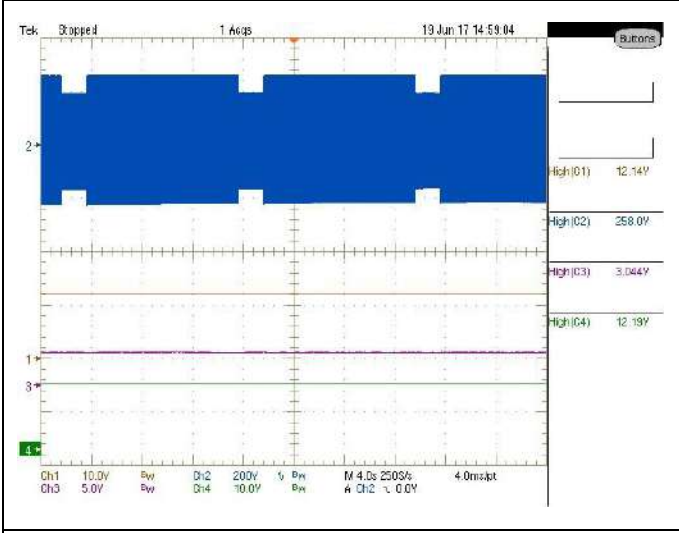

200V-25% 2 Sec min

Fig: 7

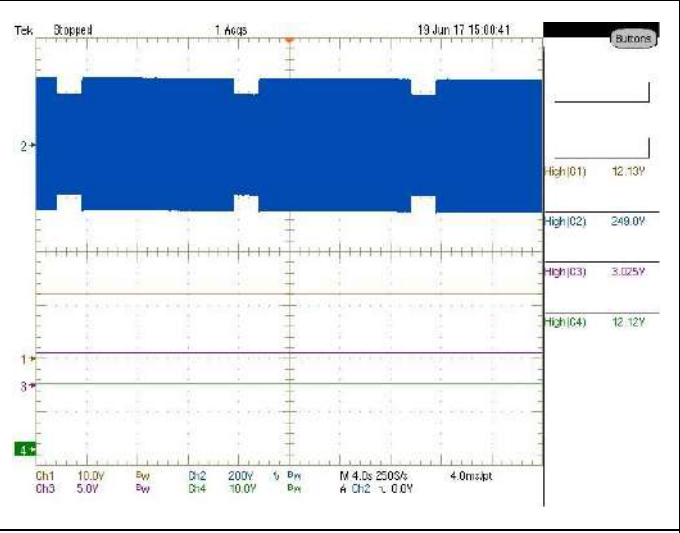

200V-25% 2 Sec max

Fig: 8

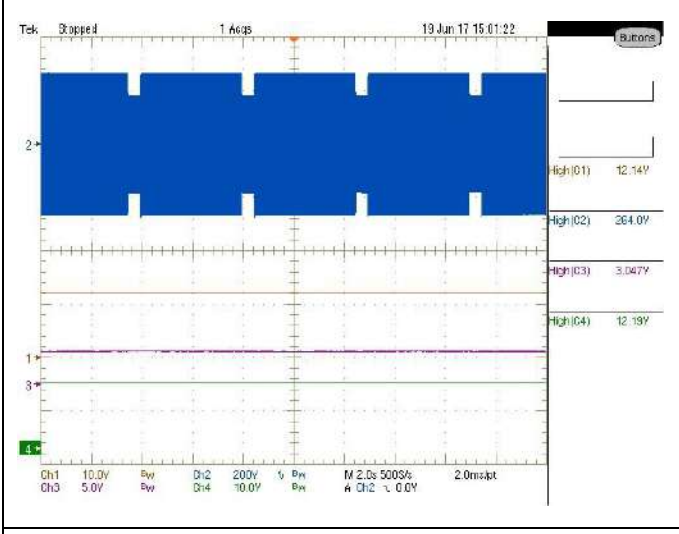

200V-32% 0.5 Sec min

Fig: 9

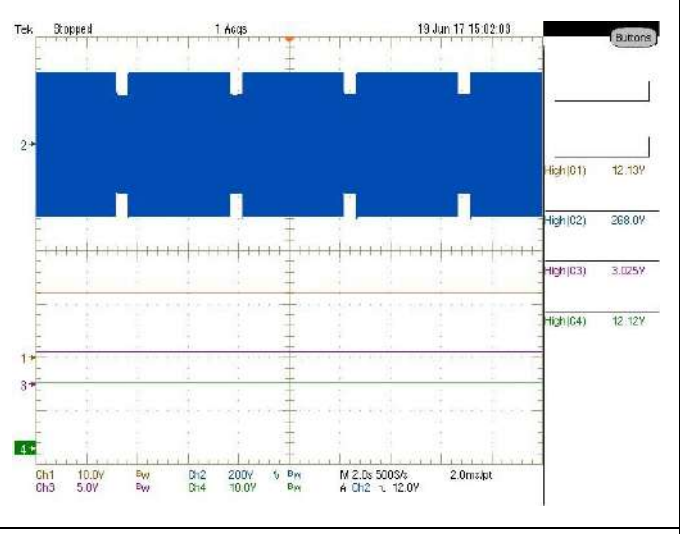

200V-32% 0.5 Sec max

Fig: 10



康舒科技

ACBEL POLYTECH INC.

Safety



® TM

Ref. Certif. No.

JPTUV-109729-M1

IEC SYSTEM FOR MUTUAL RECOGNITION OF TEST CERTIFICATES FOR ELECTRICAL EQUIPMENT (IECEE) CB SCHEME

CB TEST CERTIFICATE

Product

Switching Power Supply

Name and address of the applicant

Acbel Polytech Inc.
No. 159, Sec. 3, Danjin Rd.
Tamsui Dist., New Taipei City 251 Taiwan

Name and address of the manufacturer

Acbel Polytech Inc.
No. 159, Sec. 3, Danjin Rd.
Tamsui Dist., New Taipei City 251 Taiwan

Name and address of the factory

See additional page(s)

Ratings and principal characteristics

Input : 1)AC 100-127V; 50/60Hz; 10A MAX,
AC 200-240V; 50/60Hz; 5A MAX, DC 240V; 5A MAX,
2) AC 200-240V; 50/60Hz; 5A MAX, DC 240V; 5A MAX, Class I
Output: refer to the test report

Trademark (if any)

AcBel

Customer's Testing Facility (CTF) Stage used

CTF Stage 1

Model / Type Ref.

FSG032, R1CA2801C

Additional information (if necessary may also be reported on page 2)

For model differences, refer to the test report.
Re-issue of JPTUV-109729 dated 2020-06-05,
due to first modification.

A sample of the product was tested and found to be in conformity with

IEC 62368-1:2014
See Test Report for National Differences

As shown in the Test Report Ref. No. which forms part of this Certificate

50344080 002

This CB Test Certificate is issued by the National Certification Body



TÜV Rheinland Japan Ltd.
Global Technology Assessment Center
4-25-2 Kita-Yamata, Tsuzuki-ku
Yokohama 224-0021, Japan
Phone + 81 45 914-3888
Fax + 81 45 914-3354
Mail: info@jpn.tuv.com
Web : www.tuv.com

Date: 2022-01-18

Signature:

Dipl.-Ing. F. Stoelzel

1. AcBel Polytech (Philippines) INC.
No. 2 Tagaytay Ridge Drive,
Carmelray Industrial Park II,
Km. 54 National Highway,
Calamba City, Laguna 4027, Philippines
2. ACBEL ELECTRONIC (WUHAN) CO., LTD
No. 1, DuTai North Road
Economic Development Zone
XianTao City, HuBei Province
P.R. China
3. Acbel Electronic (Dong Guan)
Co., Ltd.
No. 17-28, Horng Yeh Road, Horng
Yeh Ind. District, Tang Xia Town
Dongguan, Guangdong 523710, P.R. China
4. Acbel Polytech Inc.
No. 159, Sec. 3, Danjin Rd.
Tamsui Dist., New Taipei City 251
Taiwan

Additional information (if necessary)

Report Ref. No. : 50344080 002

Date: 2022-01-18

Signature:



Dipl.-Ing. F. Stoelzel

經濟部標準檢驗局

BUREAU OF STANDARDS, METROLOGY AND INSPECTION,
MINISTRY OF ECONOMIC AFFAIRS



商品驗證登錄電子證書
CERTIFICATE OF THE REGISTRATION OF PRODUCT CERTIFICATION

證書號碼： CI336065676672 號 99
Certificate No.

茲據 康舒科技股份有限公司
定，准予登錄並使用商品安全標章  及識別號碼：
The application made by

申請驗證登錄，經審查結果符合規
R33567 。其登錄事項如下：
for Registration of Product

Certification has been reviewed and found to be in compliance with related regulations. Therefore, registration is granted with the
Product Safety Mark  and the Identification No. R33567 . Details of the registration are follows :

申請人：康舒科技股份有限公司
Applicant

統一編號：12341051
Uniform No.

地址：台北市松山區南京東路五段99號11樓
Address

生產廠場：詳如附表
Factory

廠址：詳如附表
Factory Address

商品種類名稱：
Type/name of product

商品分類號列：8504.40.91.00.7-A
C.C.C Code

中文名稱：交換式電源供應器
Chinese name

英文名稱：Switching Power Supply
English name

型式：FSG032
Type

系列型式：空白
Series of the type

依據標準：CNS13438 (95年版)、CNS14336-1 (99年版)、符合CNS 15663第5節「含有標
Standards 示」規定 (102年版)

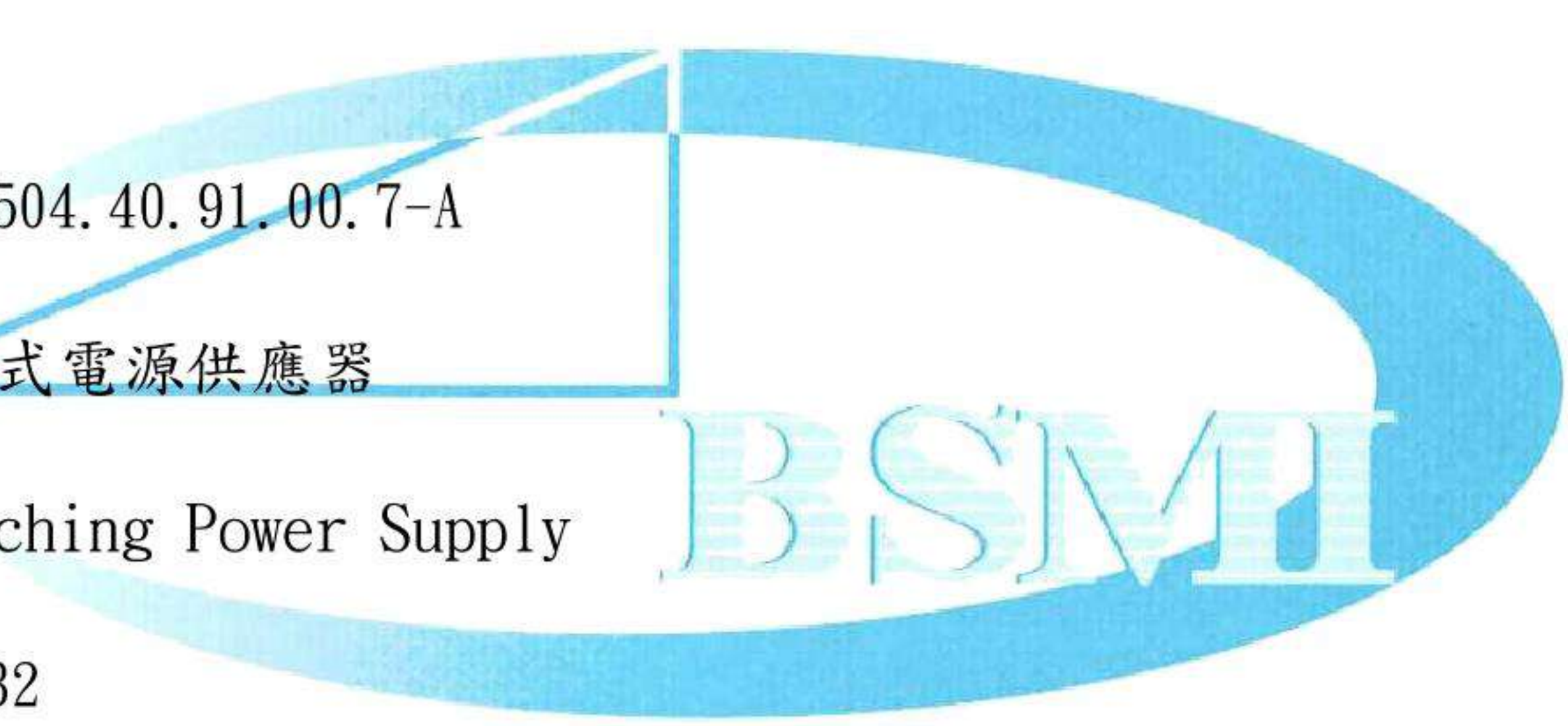

標準檢驗局發證 (發證地址：100臺北市中正區濟南路1段4號)

This certificate is issued by the BSMI. (No.4, Sec. 1, Jinan Rd., Zhongzheng Dist., Taipei City 100, Taiwan)

本證書以電子文件行之，所載內容若有不符之處，以標準局電腦資料為主，查詢驗證資料
網址：<https://civil.bsmi.gov.tw>

登錄日期：中華民國	106	年	11	月	07	日
Registration Date	2017	(year)	11	(month)	07	(day)
本證書有效期至	112	年	11	月	06	日
Expiration Date	2023	(year)	11	(month)	06	(day)
發證日期：中華民國	109	年	08	月	13	日
Date of issue	2020	(year)	08	(month)	13	(day)



註1：持本證書進口驗證登錄商品時，進口人須與本證書名義人相同。

註2：次年度商品驗證登錄年費繳納期限為當年11月30日，逾期未繳納者，經限期繳納屆期未繳納，即依商品檢
驗法第42條第7款規定廢止驗證登錄，並自次年度1月1日起生效。

註3：本證書僅代表完成檢驗程序，不作為其他(如產地)證明。

經濟部標準檢驗局
BUREAU OF STANDARDS, METROLOGY AND INSPECTION,
MINISTRY OF ECONOMIC AFFAIRS

商品驗證登錄電子證書
CERTIFICATE OF THE REGISTRATION OF PRODUCT CERTIFICATION

證書號碼： CI336065676672 號 99
Certificate No.

- 生產廠場： 1. Acbel Polytech Inc.
Factory： No. 159, Sec. 3, Danjin Rd., Tamsui Dist., New Taipei
City 251, Taiwan
2. ACBEL ELECTRONIC (WUHAN) CO., LTD
No. 1, Du Tai North Road Economic Development Zone
XianTao City, Hubei Province P.R. China
3. AcBel Electronic (Dong guan) Co., Ltd.
No.17-28, Hong Yeh Road, Hong Yeh Ind. District, Tang
Xia Town, DongGuan, Guangdong, 523710 P.R. China
4. Acbel Polytech (Philippines) Inc.
No. 2 Tagaytay Ridge Drive, Carmelray Industrial Park
II, Km. 54 National Highway, Calamba City, Laguna 4027,
Philippines

(以下空白)



CE Declaration of Conformity

For the following equipment :

Product : FSG032
Type Designation : Switching Power supply
Trademark : AcBel
Manufacturer's Name : ACBEL POLYTECH INC.
Manufacturer's Address : No.159, Sec. 3, Danjin Rd., Tamsui Dist., New Taipei City, Taiwan

Is herewith confirmed to comply with the following legal requirements set out in the Official Journal of the European Union. Products sold in the European Economic Area (EEA) have been assessed to meet high safety, health, and environmental protection requirements.

- Low-Voltage Directive 2014/35/EU : EN 62368-1:2014 + A11: 2017
- EMC Directive 2014/30/EU : EN 55032:2015+A11 :2020 ; EN 61000-3-2:2019 ; EN 61000-3-3:2013+A11 :2019
- ErP directive Commission : EN 50563:2011/A1:2013
Regulation (EU) 2019/1782
- RoHS Directive 2011/65/EU ((EU) 2015/863) : EN 50581:2012
- Additional information : DECISION No 768/2008/EC

Responsible for making this declaration is the :

- Manufacturer
- Authorized representative established within the EU
- Authorized representative established within the EU (if applicable) :

Company Name : _____

Company Address : _____

Person responsible for making this declaration

Name , Surname : Paul Huang/ Acbel Polytech Inc

Position / Title : Safety Supervisor

Taipei , Taiwan
Place

2021-12-30
Date

Legal Signature

UK Declaration of Conformity

For the following equipment :

Product : FSG032
Type Designation : Switching Power Supply
Trademark : AcBel
Manufacturer's Name : ACBEL POLYTECH INC.
Manufacturer's Address : No.159, Sec. 3, Danjin Rd., Tamsui Dist., New Taipei City, Taiwan

Is herewith confirmed to comply with the following legal requirements. Products sold in the Great Britain (GB) have been assessed to meet high safety, health, and environmental protection requirements.

- Electrical Equipment (Safety) Regulations 2016 : BS EN 62368-1:2014 + A11: 2017
- Electromagnetic Compatibility Regulations 2016 : BS EN 55032:2015+A11 :2020 ;
BS EN 55035:2017+A11 :2020
BS EN 61000-3-2:2019 ;
BS EN 61000-3-3:2013+A11 :2019
- The Ecodesign for Energy-Related Products and Energy Information (Amendment) (EU Exit) Regulations 2019 : BS EN 50563:2011/A1:2013
- The Restriction of the Use of Certain Hazardous Substances in Electrical and Electronic Equipment Regulations 2012 : BS EN 50581:2012

Responsible for making this declaration is the :

- Manufacturer
 Authorized representative established within the UK
 Authorized representative established within the UK (if applicable) :

Company Name : _____
Company Address : _____

Person responsible for making this declaration

Name , Surname : Paul Huang/ Acbel Polytech Inc
Position / Title : Safety Supervisor

Taipei , Taiwan
Place

2021-12-30
Date



Legal Signature

80 PLUS Verification and Testing Report

TYPICAL EFFICIENCY (50% Load):	96.13%
AVERAGE EFFICIENCY :	95.28%
80 PLUS COMPLIANT:	YES

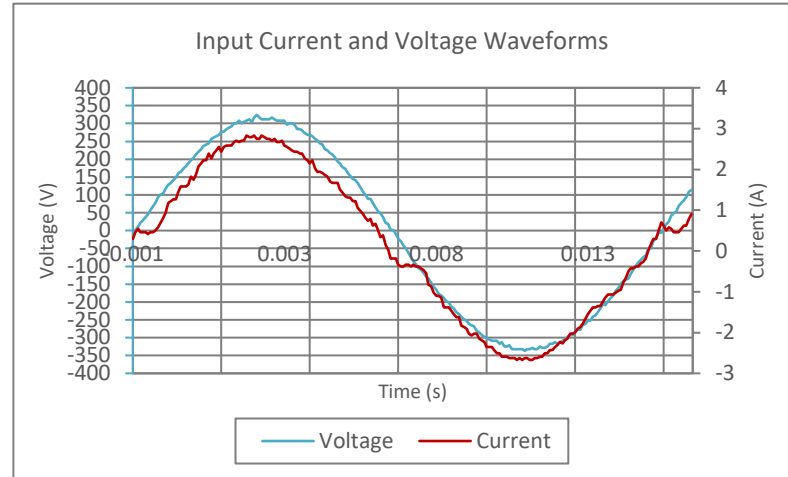

ID Number	SO-1296.1
Manufacturer	AcBel Polytech Inc.
Model Number	R1CA2801C
Serial Number	N/A
Year	2017
Type	1U
Test Date	08/08/17



Rated Specifications	Value	Units
Input Voltage	100-127 / 200-240	Volts
Input Current	10/5	Amps
Input Frequency	50-60	Hz
Rated Output Power	800	Watts

Note: All measurements were taken with input voltage at 230 V nominal and 60 Hz.

Input AC Current Waveform (ITHD = 7.44%, 50% Load)

I _{RMS}	PF	I _{THD}	Load	Fraction of Load	Input Watts	External Fan (W)*	DC Terminal Voltage (V)/ DC Load Current (A)		Output Watts	Efficiency
							12V	12Vsb		
0.42	0.93	9.28%	10%	Low	89	12.60	12.21/6.48	12.21/0.2	82	91.36%
0.76	0.98	8.40%	20%	Light	172	12.60	12.21/12.97	12.2/0.4	163	95.01%
1.86	0.99	7.44%	50%	Typical	424	12.24	12.2/32.42	12.17/1	408	96.13%
3.75	1.00	5.01%	100%	Full	860	11.88	12.19/64.83	12.12/2	814	94.70%

* Fan power is not included in the efficiency calculations

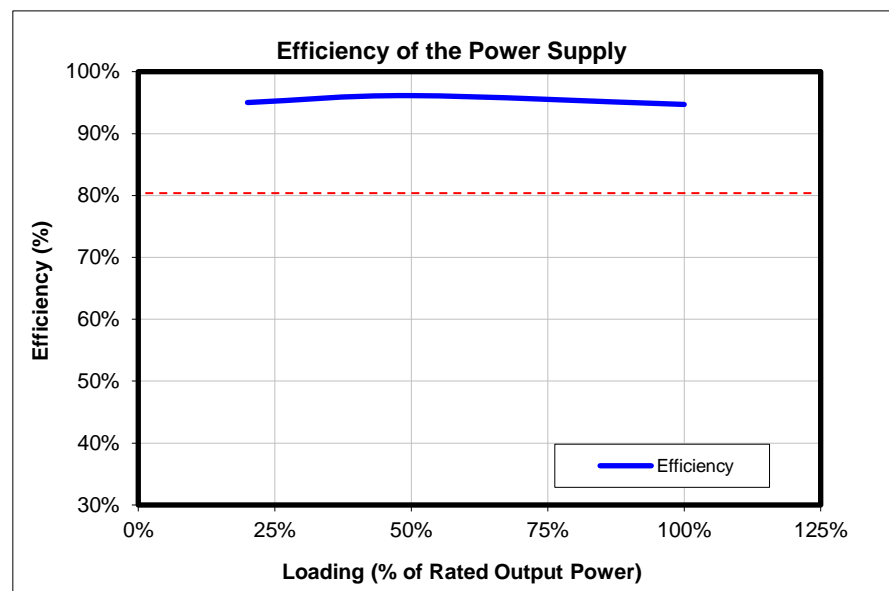
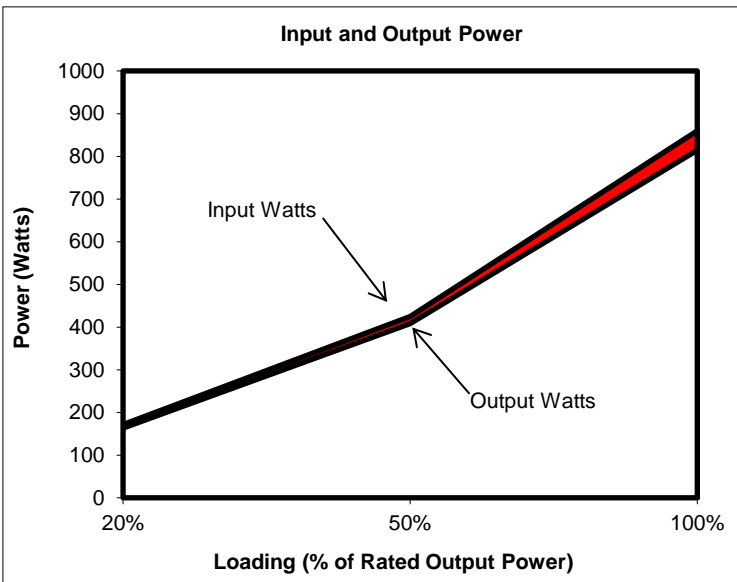

These tests were conducted by a third party independent testing firm on behalf of the 80 PLUS[®] Program. 80 PLUS is a certification program to promote highly-efficient power supplies (greater than 80% efficiency in the active mode) in technology applications. <http://www.80plus.org/>



中国国家强制性产品认证证书

证书编号：2017010907031402

委托人名称、地址

康舒科技股份有限公司
台湾新北市淡水区淡金路三段 159 号

生产者（制造商）名称、地址

康舒科技股份有限公司
台湾新北市淡水区淡金路三段 159 号

生产企业名称、地址

康舒电子(东莞)有限公司
中国广东省东莞市塘厦镇宏业工业区宏业大道 17-28 号

产品名称和系列、规格、型号

开关电源

FSG032 输入: 1) 100-127Vac, 50/60Hz, 10A MAX, 200-240Vac, 50/60Hz, 5A MAX; 240Vdc, 5A MAX ; 2) 200-240Vac, 50/60Hz, 5A MAX; 240Vdc, 5A MAX ; 直流输出: +12V/65A; +12Vsb/2A; 最大总功率 800W。(不带电线组件销售, 仅适用于海拔 5000 米及以下)

产品标准和技术要求

GB17625.1-2012; GB4943.1-2011; GB/T9254-2008 (Class A)

上述产品符合强制性产品认证实施规则 CNCA-C09-01:2014 的要求,
特发此证。

发证日期: 2017 年 12 月 14 日 有效期至: 2022 年 12 月 14 日

证书有效期内本证书的有效性依据发证机构的定期监督获得保持。

本证书的相关信息可通过国家认监委网站 www.cnca.gov.cn 查询



主任:



中国质量认证中心



CERTIFICATE FOR CHINA COMPULSORY PRODUCT CERTIFICATION

CERTIFICATE NO.: 2017010907031402

NAME AND ADDRESS OF THE APPLICANT

Acbel Polytech Inc.
No.159, Sec. 3, Danjin Rd., Tamsui Dist., New Taipei City 251, Taiwan

NAME AND ADDRESS OF THE MANUFACTURER

Acbel Polytech Inc.
No.159, Sec. 3, Danjin Rd., Tamsui Dist., New Taipei City 251, Taiwan

NAME AND ADDRESS OF THE FACTORY

Acbel Electronic (Dong Guan) Co., Ltd.
No. 17-28, Horng Yeh Road, Horng Yeh Industrial District, Tang Xia Town, Dong Guan City, Guang Dong Province, China

PRODUCT NAME, MODEL AND SPECIFICATION

Switching power Supply

FSG032 I/P: 1) 100-127Vac , 50/60Hz, 10A MAX ,200-240Vac, 50/60Hz, 5A MAX; 240Vdc, 5A MAX ; 2) 200-240Vac, 50/60Hz, 5A MAX; 240Vdc, 5A MAX ; DC-Output: +12V/65A; +12Vsb/2A, TOTAL POWER 800W MAX. (Sale without cord set, Altitude up to 5000m)

THE STANDARDS AND TECHNICAL REQUIREMENTS FOR THE PRODUCTS

GB17625.1-2012;GB4943.1-2011;GB/T9254-2008(Class A)

This is to certify that the above mentioned product(s) complies with the requirements of implementation rules for compulsory certification(REFNO.CNCA-C09-01:2014).

Valid from: Dec.14,2017

Valid until: Dec.14,2022

The validity of the certificate is subject to positive result of the regular follow up inspection by issuing certification body until the expiry date.

The certificate information is available through CNCA's website: www.cnca.gov.cn



President:

Wang Kejiao



CHINA QUALITY CERTIFICATION CENTRE

CERTIFICATE OF COMPLIANCE

Certificate Number E131875
Report Reference E131875-A6043-UL
Date 2020-November-03

Issued to: ACBEL POLYTECH INC
No159 Sec 3 Danjin Rd
TamSui District
New Taipei251 TW

**This is to certify that
representative samples of**

POWER SUPPLIES FOR USE WITH AUDIO/VIDEO,
INFORMATION AND COMMUNICATION TECHNOLOGY
EQUIPMENT - COMPONENT

See Addendum Page for Product Designation(s).

Have been investigated by UL in accordance with the component requirements in the Standard(s) indicated on this Certificate. UL Recognized components are incomplete in certain constructional features or restricted in performance capabilities and are intended for installation in complete equipment submitted for investigation to UL LLC.

Standard(s) for Safety: UL 62368-1 & CAN/CSA C22.2 No. 62368-1-14 -
Audio/video, information and communication technology
equipment Part 1: Safety requirements.

Additional Information: See the UL Online Certifications Directory at
<https://iq.ulprospector.com> for additional information

This *Certificate of Compliance* does not provide authorization to apply the UL Recognized Component Mark. Only the UL Follow-Up Services Procedure provides authorization to apply the UL Mark.

Only those products bearing the UL Recognized Component Mark should be considered as being UL Certified and covered under UL's Follow-Up Services.

Look for the UL Recognized Component Mark on the product.

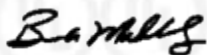

Bruce Mahrenholz, Director North American Certification Program

UL LLC

Any information and documentation involving UL Mark services are provided on behalf of UL LLC (UL) or any authorized licensee of UL. For questions, please contact a local UL Customer Service Representative at <http://ul.com/aboutul/locations/>



CERTIFICATE OF COMPLIANCE

Certificate Number E131875
Report Reference E131875-A6043-UL
Date 2020-November-03

This is to certify that representative samples of the product as specified on this certificate were tested according to the current UL requirements

Product Designation(s): Switching Power Supply

Model: FSG032

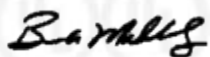

Bruce Mahrenholz, Director North American Certification Program

UL LLC

Any information and documentation involving UL Mark services are provided on behalf of UL LLC (UL) or any authorized licensee of UL. For questions, please contact a local UL Customer Service Representative at <http://ul.com/aboutul/locations/>





안전확인신고증명서 Confirmation Letter of Declaration

신고번호: XU100121-22213A
(Application No.)

신고회사명: Acbel Electronic (Dongguan) Co.,Ltd.
(Applicant)

주소: No.17-28 (Hong Yeh Rd) Hong Yeh Industrial District, Tang Xia
(Address) Town, Dongguan, Guangdong, China

제품명: 컴퓨터용 전원공급장치
(Product)

기본모델명: FSG032
(Basic Model)

파생모델명 (Series Model):
R1CA2801C

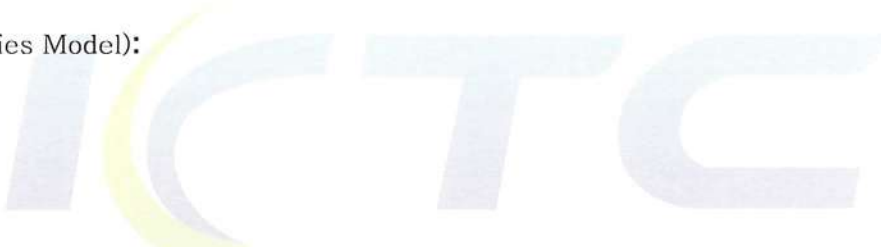

정격/안전기준상의 모델구분: I/P: 200-240 V~, 50/60 Hz, 5 A MAX (O/P: + 12 V/65 A,
(Rating) + 12 Vsb/2 A, TOTAL POWER 800 W MAX.)

안전기준: K 60950-1(2011-12)
(Standard)

본 확인신고는 **제조국명:** 중국
제조업자명: Acbel Electronic (Dongguan) Co.,Ltd.
제조공장의 주소: No.17-28 (Hong Yeh Rd) Hong Yeh Industrial District, Tang Xia
Town, Dongguan, Guangdong, China
의 제품에만 해당함

「전기용품 및 생활용품 안전관리법 시행규칙」 제28조제1항, 같은 조 제3항, 제29조제2항 또는 제34조제2항에 따라 안전확인신고 증명서를 발급합니다.
We issue this Confirmation Letter of Declaration of the Safety Confirmation for the above appliances in accordance with Article 28(1), 28(3), 29(2) or 34(2) of the Electrical Appliances and Consumer Products Safety Control Act.

2022 년 02 월 03 일
(Year) (Month) (Day)



한국기계전자시험연구원
Korea Testing Certification



※ 이 신고증명서는 「전기용품 및 생활용품 안전관리법」에 따른 제품의 안전성 확인에 한정된 것이며, 그 밖의 다른 법률이 적용되는 제품의 경우에는 해당 법률에 따라 추가로 인증·허가 등을 받아야 합니다.

첨부서류	1. 전기용품의 안전관리부품 및 재질목록 (List of Critical Components)(전기용품에 한정한다) 2. 기본모델 · 파생모델의 내용 (Descriptions of the basic and series model) 3. 안전확인신고 내용의 변경 현황 (Revisions Status)
------	---

기술문서 Technical Document

page: 1 / 15

안전인증번호: XU100121-22213A
(Certificate No)

접수번호: 20220118 - 0019
(Receipt No)

1. 기본모델 · 파생모델의 내용 (General Descriptions of Certified Products)

1.1 제품의 설명 (Product description)

인증제품의 개요는 다음과 같다.

(Information on certified basic model product is as follow)

구분 (Section)	내용 (Description)
용도 (Normal use)	The apparatus designed to be used for converting AC main voltage to DC low voltage for computer use.
내부구조 (Internal construction)	The apparatus consist of switching transformer, rectifying part etc.
외부구조 (External construction)	Providing with metal enclosure with appliance inlet.
기타 (Others)	Class I. CB Test Certificate is issued by TUV Rheinland Japan Ltd. (JPTUV-083488-M2)

1.2 전기용품의 표시: 전기용품 및 생활용품 안전관리법 시행규칙 제37조(안전확인대상제품의표시)에 따라 표시한다.

(Marking of KC Mark: Marking shall comply with the Article 37 of the Enforcement Rule of the Electrical Appliances and Consumer Products Safety Control Act.)

1.3 등록모델 (Registered Models)

구분 (Class)	모델명 및 정격 (Model / Rating)	기본모델과의 차이점 (Difference between basic model and series model)
기본모델 (Basic model)	FSG032 I/P: 200-240 V~, 50/60 Hz, 5 A MAX (O/P: +12 V/65 A, +12 Vsb/2 A, TOTAL POWER 800 W MAX.)	
파생모델 (Series model)	R1CA2801C	Model name



기술 문서 Technical Document

page: 2 / 15

안전인증번호: XU100121-22213A
(Certificate No)

접수번호: 20220118 - 0019
(Receipt No)

2. 안전관리 부품 및 재질목록(List of Critical Components)

부품명(회로기호) Components(Part no.)	제조사(상표명) Manufacturer(Brand)	모델명(형식) Model(Type)	정격 또는 특성 (Technical Data)	인증규격 (Certification)
Appliance inlet	Canal Electronic Co Ltd	KS series	10 A, 250 Vac	IEC
(Alt.)	Tecx-Unions Technology Corp.	TU-301 series (-A/AP/AP-A/S/SP)	10 A, 250 Vac	IEC
(Alt.)	Inalways Corp (International All Ways Ind Co Ltd)	0711 series	10 A, 250 Vac	IEC
(Alt.)	Rong Feng Industrial Co Ltd	SS-120	10 A, 250 Vac	IEC
(Alt.)	Rich Bay Co Ltd	R-301SN	10 A, 250 Vac	IEC
(Alt.)	Zhe Jiang Bei Er Jia Electronic Co Ltd	ST-A01-003K/ ST-A01-003J	10 A, 250 Vac	IEC
(Alt.)	SHENG MING ENTERPRISE CO LTD (WINTRON ENTERPRISE CO LTD)	S14-102	10 A, 250 Vac	IEC
(Alt.)	Solteam Electronics Co Ltd	ST-01 series	10 A, 250 Vac	IEC
(Alt.)	Delta Electronics Inc	SK-1034B	10 A, 250 Vac	IEC
(Alt.)	HCR Electronics Co., Ltd.	SK01	10 A, 250 Vac	IEC
Fuse (F1)	LITTELFUSE INC	487	F12.5 AL, 420 Vdc/ac	UL
(Alt.)	HOLLYLAND CO LTD	5HF, 5HF(P)	F12.5 AL, 420 Vdc/ac	UL
(Alt.)	Conquer Electronics Co Ltd	UBF-A	F12.5 AL, 420 Vdc/ac	UL
(Alt.)	Walter Electronic Co. Ltd	FHP	F12.5 AL, 420 Vdc/ac	UL
Fuse (F3)	Conquer Electronics Co Ltd	PGU	F6.3 AL, 250 Vac	IEC
(Alt.)	Walter Electronic Co. Ltd.	FDP	F6.3 AL, 250 Vac	IEC
(Alt.)	Conquer Electronics Co Ltd	PBU	F6.3 A, 250 Vac	IEC

[서식 CP401-18-00]



기술문서 Technical Document

page: 3 / 15

안전인증번호: XU100121-22213A
(Certificate No)

접수번호: 20220118 - 0019
(Receipt No)

부품명(회로기호) Components(Part no.)	제조사(상표명) Manufacturer (Brand)	모델명(형식) Model (Type)	정격 또는 특성 (Technical Data)	인증규격 (Certification)
Fuse (F201)	Conquer Electronics Co Ltd	PBU	F1 AL, 250 Vac	IEC
(Alt.)	Walter Electronic Co. Ltd.	FDP	F1 AL, 250 Vac	IEC
X-Cap. (C196, C4, C7) C196 max. 0.1 μ F; C4 max. 1 μ F; C7 max. 0.47 μ F (C196 located before fuse and secured on appliance inlet) (Optional)	Arcotronics Italia SPA for IMQ-ENEC	R.46	250 Vac min., 110 $^{\circ}$ C	IEC
(Alt.)	Hua Jung Components Co Ltd	MKP	250 Vac min., 110 $^{\circ}$ C	IEC
(Alt.)	SHENZHEN JINGHAO CAPACITOR CO LTD	CBB62B	250 Vac min., 110 $^{\circ}$ C	IEC
(Alt.)	YIMANFENG SCIENCE AND TECHNOLOGY LTD CO	MPX/MKP	250 Vac min., 110 $^{\circ}$ C	IEC
(Alt.)	Okaya Electric Industries Co., Ltd	XF	250 Vac min., 110 $^{\circ}$ C	IEC
(Alt.)	Strong Capacitor Co. Ltd.	Type MPX	250 Vac min., 110 $^{\circ}$ C	IEC
(Alt.)	Vishay Capacitors Belgium NV	F1778	250 Vac min., 110 $^{\circ}$ C	IEC
(Alt.)	Arcotronics Italia SPA for IMQ-ENEC	F861	250 Vac min., 110 $^{\circ}$ C	IEC
(Alt.)	ZHUHAI SUNG HO ELECTRONICS CO LTD	CMPP	250 Vac min., 105 $^{\circ}$ C	IEC
(Alt.)	Okaya Electric Industries Co., Ltd	RE series	250 Vac min., 100 $^{\circ}$ C	IEC
(Alt.)	Okaya Electric Industries Co., Ltd	LE series	250 Vac min., 100 $^{\circ}$ C	IEC
(Alt.)	Cheng Tung Industrial Co Ltd	CTX	250 Vac min., 100 $^{\circ}$ C	IEC
(Alt.)	Epcos Electronic Components S.A.	B3292 series	250 Vac min., 100 $^{\circ}$ C	IEC
(Alt.)	Vishay Capacitors Belgium NV	F1772	250 Vac min., 100 $^{\circ}$ C	IEC

[서식 CP401-18-00]



기술문서 Technical Document

page: 4 / 15

안전인증번호: XU100121-22213A
(Certificate No)

접수번호: 20220118 - 0019
(Receipt No)

부품명(회로기호) Components(Part no.)	제조사(상표명) Manufacturer(Brand)	모델명(형식) Model(Type)	정격 또는 특성 (Technical Data)	인증규격 (Certification)
(Alt.)	KEMET ELECTRONICS OY (Evox Rifa Group Oyj)	PHE840M	250 Vac min., 105 ℃	IEC
(Alt.)	Carli Electronics Co Ltd	MPX	250 Vac min., 100 ℃	IEC
(Alt.)	Panasonic Corporation	ECQUL	250 Vac min., 100 ℃	IEC
(Alt.)	SHENZHEN SURONG CAPACITORS CO LTD	MPX/MKP	250 Vac min., 100 ℃	IEC
Y-Cap. (C198, C199, C5, C6) C198, C199 max. 2200 pF; C5, C6 max. 1000 pF (C198, C199 located before fuse and secured on appliance inlet) (Optional)	Murata Mfg Co Ltd	KX	250 Vac min., 125 ℃	IEC
(Alt.)	Murata Mfg Co Ltd	RA	250 Vac min., 125 ℃	IEC
(Alt.)	Murata Mfg Co Ltd	KH	250 Vac min., 125 ℃	IEC
(Alt.)	Murata Mfg Co Ltd	KY	250 Vac min., 125 ℃	IEC
(Alt.)	TDK-EPC Corporation	CD	250 Vac min., 125 ℃	IEC
(Alt.)	TDK-EPC Corporation	CS	250 Vac min., 125 ℃	IEC
(Alt.)	Walsin Technology Corp (Pan Overseas Electronic Co Ltd)	AH	250 Vac min., 125 ℃	IEC
(Alt.)	Walsin Technology Corp (Pan Overseas Electronic Co Ltd)	AC	250 Vac min., 125 ℃	IEC
(Alt.)	Success Electronics Co Ltd	SE	250 Vac min., 125 ℃	IEC
(Alt.)	Success Electronics Co Ltd	SB	250 Vac min., 125 ℃	IEC
(Alt.)	Success Electronics Co Ltd	SF	250 Vac min., 125 ℃	IEC

[서식 CP401-18-00]



기술문서 Technical Document

page: 5 / 15

안전인증번호: XU100121-22213A
(Certificate No)

접수번호: 20220118 - 0019
(Receipt No)

부품명(회로기호) Components(Part no.)	제조사(상표명) Manufacturer (Brand)	모델명(형식) Model (Type)	정격 또는 특성 (Technical Data)	인증규격 (Certification)
(Alt.)	Vishay Electronic GMBH Draloric (Roederstein Electronics Inc)	VY1	250 Vac min., 125 ℃	IEC
(Alt.)	Vishay Electronic GMBH Draloric (Roederstein Electronics Inc)	VY2	250 Vac min., 125 ℃	IEC
(Alt.)	Holy Stone Enterprise Co., Ltd.	SDC series	250 Vac min., 125 ℃	IEC
(Alt.)	YINAN DON'S ELECTRONIC COMPONENT CO LTD	CT81	250 Vac min., 125 ℃	IEC
(Alt.)	NAN JING YUYUE ELECTRONICS CO LTD	CT7	250 Vac min., 125 ℃	IEC
(Alt.)	Fenghua Advanced Technology (Holding) CO. LTD	CT7	250 Vac min., 125 ℃	IEC
Bridge-Cap. (C17) max. 2200 pF (Optional)	Murata Mfg Co Ltd	KX	250 Vac min., 125 ℃	IEC
(Alt.)	Murata Mfg Co Ltd	RA	250 Vac min., 125 ℃	IEC
(Alt.)	TDK-EPC Corporation	CD	250 Vac min., 125 ℃	IEC
(Alt.)	Walsin Technology Corp (Pan Overseas Electronic Co Ltd)	AH	250 Vac min., 125 ℃	IEC
(Alt.)	Success Electronics Co Ltd	SE	250 Vac min., 125 ℃	IEC
(Alt.)	Success Electronics Co Ltd	SB	250 Vac min., 125 ℃	IEC
(Alt.)	Vishay Electronic GMBH Draloric (Roederstein Electronics Inc)	VY1	250 Vac min., 125 ℃	IEC
(Alt.)	Holy Stone Enterprise Co., Ltd.	SDC series	250 Vac min., 125 ℃	IEC



기술문서 Technical Document

page: 6 / 15

안전인증번호: XU100121-22213A
(Certificate No)

접수번호: 20220118 - 0019
(Receipt No)

부품명(회로기호) Components(Part no.)	제조사(상표명) Manufacturer(Brand)	모델명(형식) Model(Type)	정격 또는 특성 (Technical Data)	인증규격 (Certification)
(Alt.)	YINAN DON'S ELECTRONIC COMPONENT CO LTD	CT81	250 Vac min., 125 ℃	IEC
(Alt.)	NAN JING YUYUE ELECTRONICS CO LTD	CT7	250 Vac min., 125 ℃	IEC
Varistor (MOV1) (Optional)	Lien Shun Electronics Co., Ltd. for VDE; Brightking (ShenZhen) Co Ltd for UL	xxDyyyK (xx: 14, 20, 25; yyy: 471, 511, 561, 621, 681, 751, 781, 821, 911, 102, 112, 122)	300, 320, 350, 385, 420, 460, 485, 510, 550, 625, 680, 750 Vac; 40/85/56 6KV/3KA pulse test passed (coating V-0)	VDE, UL
(Alt.)	Thinking Electronic Industrial Co Ltd (Wujin Thinking Electronic Co Ltd)	TVR10yyy-D series (yyy: 471, 511, 561, 621, 681, 751, 821, 911, 102, 112)	300, 320, 350, 395, 420, 465, 510, 550, 625, 680 Vac, 40/85/56 6KV/3KA pulse test passed (coating V-0)	VDE, UL
(Alt.)	Thinking Electronic Industrial Co Ltd (Wujin Thinking Electronic Co Ltd)	TVR10yyy-V series (yyy: 471, 511, 561, 621, 681, 751, 821, 911, 102, 112)	300, 320, 350, 395, 420, 465, 510, 550, 625, 680 Vac, 40/85/56 6KV/3KA pulse test passed (coating V-0)	VDE, UL
(Alt.)	Thinking Electronic Industrial Co Ltd (Wujin Thinking Electronic Co Ltd)	TVRxxyyy series (xx: 14, 20; yyy: 471, 511, 561, 621, 681, 751, 821, 911, 102, 112)	300, 320, 350, 395, 420, 465, 510, 550, 625, 680 Vac, 40/85/56 6KV/3KA pulse test passed (coating V-0)	VDE, UL
(Alt.)	Thinking Electronic Industrial Co Ltd (Wujin Thinking Electronic Co Ltd)	TVRxxyyy-M series (xx: 14, 20; yyy: 471, 511, 561, 621, 681, 751)	300, 320, 350, 395, 420, 465, 510, 550, 625, 680 Vac, 40/125/56 6KV/3KA pulse test passed (coating V-0)	VDE, UL
(Alt.)	Joyin Co. Ltd	xxSyyyK (xx: 10, 14, 20; yyy: 471, 511, 561, 621, 681, 751, 781, 821, 911, 102, 112)	300, 320, 350, 385, 420, 460, 485, 510, 550, 625, 680 Vac; 40/85/56 6KV/3KA pulse test passed (coating V-0)	VDE, UL
(Alt.)	Joyin Co. Ltd	xxNyyyK (xx: 10, 14, 20; yyy: 471, 511, 561, 621, 681, 751, 781, 821, 911, 102, 112, 182)	300, 320, 350, 385, 420, 460, 485, 510, 550, 625, 680, 1000 Vac; 40/85/56 6KV/3KA pulse test passed (coating V-0)	VDE, UL



기술문서 Technical Document

page: 7 / 15

안전인증번호: XU100121-22213A
(Certificate No)

접수번호: 20220118 - 0019
(Receipt No)

부품명(회로기호) Components(Part no.)	제조사(상표명) Manufacturer(Brand)	모델명(형식) Model(Type)	정격 또는 특성 (Technical Data)	인증규격 (Certification)
(Alt.)	Littelfuse Inc. for UL; DongGuan Littelfuse Electronics Co Ltd for VDE	CIII series / LA series VxxxL Ayy series for UL (xxx:300, 320, 385, 420, 460, 480, 510, 550, 575, 625, 660, 680; yy:10, 20, 40, 50, 80, 100)	300, 320, 385, 420, 460, 480, 510, 550, 575, 625, 660, 680 Vac; 40/85/56 6KV/3KA pulse test passed (coating V-0)	VDE, UL
(Alt.)	EPCOS (ZHUHAI FTZ) CO LTD (Epcos OHG(Siemens AG))	S(NF)xxKyyy (xx: 14, 20; yyy: 300, 320, 350, 385, 420, 440, 460, 510, 550, 625, 680, 1000)	300, 320, 350, 385, 420, 440, 460, 510, 550, 625, 680, 1100 Vac, 40/85/56 6KV/3KA pulse test passed	VDE, UL
(Alt.)	EPCOS (ZHUHAI FTZ) CO LTD (Epcos OHG(Siemens AG))	Q20Kyyy (yyy: 300, 320)	300, 320 Vac, 40/85/56 6KV/3KA pulse test passed (coating V-0)	VDE, UL
(Alt.)	EPCOS (ZHUHAI FTZ) CO LTD (Epcos OHG(Siemens AG))	S(NF)10KyyyE2 K1 (yyy: 300, 320, 350, 385, 420, 460, 510, 550, 625, 680)	300, 320, 350, 385, 420, 440, 460, 510, 550, 625, 680 Vac, 40/85/56 6KV/3KA pulse test passed (coating V-0)	VDE, UL
(Alt.)	BRIGHTKING (SHENZHEN) CO LTD	yyyKDxx (xx: 10, 14, 20; yyy: 471, 511, 561, 621, 681, 751, 781, 821, 911, 102, 112)	300, 320, 350, 385, 420, 460, 485, 510, 550, 625, 680 Vac, 40/85/56 6KV/3KA pulse test passed (coating V-0)	VDE, UL
(Alt.)	NIPPON CHEMICON CORP	TND10SEyyyK/ TNR10SEyyyK series (yyy: 621, 681, 751, 781, 821, 911, 102, 112, 182) TND12SEyyyK/ TNR12SEyyyK series (yyy: 471, 511, 561, 621, 681, 751, 781, 821, 911, 102, 112, 182)	300, 320, 350, 395, 420, 465, 510, 550, 625, 680 Vac, 40/85/56 6KV/3KA pulse test passed	VDE, UL
(Alt.)	SANADA KOA CORPORATION	NVF10Uxyz470 (x or y or z Can be " A-Z")	300 Vac, 40/85/56 6KV/3KA pulse test passed	VDE, UL
(Alt.)	GUANGDONG FENGHUA ADVANCED TECHNOLOGY HOLDING CO LTD./ XIANHUA NEW SENSITIVE COMPONENTS BRANCH	FNR-14Kyyy (yyy: 471, 511, 561, 621, 681, 751, 781, 821, 911, 102, 112, 182)	300, 320, 350, 385, 420, 460, 485, 510, 550, 625, 680 Vac, 40/85/56 6KV/3KA pulse test passed (coating V-0)	UL



기술문서 Technical Document

page: 8 / 15

안전인증번호: XU100121-22213A
(Certificate No)

접수번호: 20220118 - 0019
(Receipt No)

부품명(회로기호) Components(Part no.)	제조사(상표명) Manufacturer(Brand)	모델명(형식) Model(Type)	정격 또는 특성 (Technical Data)	인증규격 (Certification)
Optical Isolator (M202, M203)	Everlight Elertronic (China) Co., Ltd.	CNY series for UL. CNY-171 series., CNY17F1 series., EL610. ("." Can be "blank, A-Z or numbers and denote different pin shape.)	Minimum 3000 Vac, thermal cycling test passed by FIMKO, Insulation thickness =0.5mm, internal creepage=6mm, external creepage=7.7 mm ; 110°C	UL
(Alt.)	Vishay semiconductor GMBH (Vishay Infrared Components Inc)	TCLT10xx series (xx can be "00-03, 06-09"), TCLT11xx series (xx can be "01-03, 06-09"), TCLT1600 series.	Minimum 4800 Vac, Thermal cycling test passed by FIMKO, external creepage=8.2mm 100°C	VDE, UL
(Alt.)	RENESAS ELECTRONICS CORPORATION (NEC Electronics Corp Compound Semiconductor Device Div)	PS2381-1	Minimum 5000 Vac Insulation thickness = 0.4mm, thermal cycling test passed by FIMKO, external creepage 8mm min. 115°C	VDE, UL
(Alt.)	Cosmo Electronics Corporation	KT1yxx series (y can be "0-4 and 6", xx can be "CTR Rank, 00-zz")	Minimum 4800 Vac, OVC II, Pollution Degree 2 and 2000m. Insulation thickness = 0.7mm, thermal cycling test passed by FIMKO, external creepage=8.6mm 115°C	VDE, UL
(Alt.)	Everlight Elertronic (China) Co., Ltd.	EL817 series	Minimum 3000 Vac, thermal cycling test passed by NEMKO, Insulation thickness =0.5mm, internal creepage=6mm, external creepage=7.7mm ; 110°C	VDE, UL
(Alt.)	RENESAS ELECTRONICS CORPORATION (NEC Electronics Corp Compound Semiconductor Device Div)	PS2561 series	Minimum 5000 Vac, Insulation thickness =0.4mm, thermal cycling test passed by FIMKO, external creepage=7mm 100°C	VDE, UL
(Alt.)	Cosmo Electronics Corporation	K1010 series	Minimum 5000 Vac Insulation thickness =0.5mm, thermal cycling tested by FIMKO , external creepage=6.5mm 115°C	VDE, UL



기술문서 Technical Document

page: 9 / 15

안전인증번호: XU100121-22213A
(Certificate No)

접수번호: 20220118 - 0019
(Receipt No)

부품명(회로기호) Components(Part no.)	제조사(상표명) Manufacturer(Brand)	모델명(형식) Model(Type)	정격 또는 특성 (Technical Data)	인증규격 (Certification)
(Alt.)	Vishay Semiconductor GMBH (Vishay Infrared Components Inc)	VOL617 series/ VOL618A series	Minimum 5000 Vac Insulation thickness >0.4m m, thermal cycling tested by FIMKO, external creepage>8.0mm 110°C	VDE, UL
(Alt.)	Lite-on Technology Co. (Lite-on Electronic, Inc.)	LTV-817	Minimum 5000 Vac Insulation thickness =0.8mm, internal creepage=5.2mm, external creepage=7.8mm 100°C	VDE, UL
(Alt.)	EVERLIGHT ELECTRONICS CO LTD	EL101 series	Minimum 3000 Vac, thermal cycling test passed by NEMKO, Insulation thickness =0.4mm, external creepage=8.1mm ; 110°C	UL
(Alt.)	LITE-ON TECHNOLOGY CORP	LTV-100x (x can be 0~9)	Minimum 5000 Vac Insulation thickness >0.4mm, thermal cycling tested by FIMKO, external creepage=8.3mm 100°C	VDE, UL
(Alt.)	Changzhou Galaxy Century Micro-electronics Co., Ltd.	BL817	Minimum 6000 Vac, thermal cycling test passed by VDE, Insulation thickness =0.8mm, external creepage=7.4mm ; 125°C	VDE, UL
Discharge Resistor (RHV20, RHV21, RHV22) (located before fuse)	Ralec Electronic Corp	RTV06 series	1/4 W , 332 kΩ	-
(Alt.)	TA-I Technology Co Ltd	RH series	1/4 W , 332 kΩ	-
(Alt.)	Yageo Corp	RV1206 series	1/4 W , 332 kΩ	-
(Alt.)	Kamaya Electric Co Ltd	RVC32 series	1/4 W , 332 kΩ	-
(Alt.)	PROSPERITY DIELECTRICS CO LTD	FVF06...B series	1/4 W , 332 kΩ	-
Discharge Resistor (RHV1, RHV2, RHV3)	Interchangeable	Interchangeable	1/4 W , 332 kΩ	-
Relay (REL1) (optional)	Good Sky Electric Co. Ltd.	EZ-SS-112DM	250 Vac, 16 A; 30 Vdc, 16 A	UL, TUV
(Alt.)	Good Sky Electric Co. Ltd.	GQ-SS/ SH-112LM1	250 Vac, 10 A for TUV 125/250 Vac, 10 A for UL	UL, TUV

[서식 CP401-18-00]



기술문서 Technical Document

page: 10 / 15

안전인증번호: XU100121-22213A
(Certificate No)

접수번호: 20220118 - 0019
(Receipt No)

부품명(회로기호) Components(Part no.)	제조사(상표명) Manufacturer(Brand)	모델명(형식) Model(Type)	정격 또는 특성 (Technical Data)	인증규격 (Certification)
(Alt.)	Song Chuan Precision Co Ltd	207 series/ 207H series	250 Vac, 17 A for VDE 277 Vac, 20 A for UL	UL, VDE
(Alt.)	Song Chuan Precision Co Ltd	307HN-1AH/ 1AHA-F-C	277 Vac, 10 A for UL; 250 Vac, 10 A for VDE	UL, VDE
(Alt.)	DONGGUAN GOLDEN ELECTRICAL APPLIANCE CO LTD	GI-1A-12LHF	250 Vac, 10 A	UL, TUV
(Alt.)	Song Chuan Precision Co Ltd	507HN-1CH-F-C	277 Vac, 17 A for UL; 250 Vac, 17 A for VDE	UL, VDE
(Alt.)	Tyco Electronics (ShenZhen) Co. Ltd	OZ-SS-124LM1	240 Vac, 16 A; 24 Vdc, 16 A	UL, TUV
(Alt.)	Tyco Electronics (ShenZhen) Co. Ltd	OZ-SS-112L	240 Vac, 16 A; 30 Vdc, 16 A	UL, TUV
(Alt.)	Tyco Electronics (ShenZhen) Co. Ltd	OZ-SS-112LM1	240 Vac, 16 A; 30 Vdc, 16 A	UL, TUV
(Alt.)	Tyco Electronics (ShenZhen) Co. Ltd	PCFN-112D2M	250 Vac, 25 A	UL, TUV
(Alt.)	Tyco Electronics (ShenZhen) Co. Ltd	OJE-SS- 112HMF	250 Vac, 10 A	UL, TUV
(Alt.)	Tyco Electronics (ShenZhen) Co. Ltd	OJE-SS- 112HM2	250 Vac, 10 A	UL, TUV
(Alt.)	Good Sky Electric Co. Ltd.	RWH-SH- 112DM	250 Vac, 12 A; 24 Vdc, 15 A	UL, TUV
(Alt.)	Panasonic Corporation	ADJ, followed by 1, 2, 3, followed by 1, 2, 3, 4, 5 or 6 , followed by 0 or 1, followed by 05* thru 48*	277 Vac, 16 A for UL; 250 Vac, 16 A for VDE	UL, VDE
(Alt.)	XIAMEN HONGFA ELECTRO ACOUSTIC CO LTD	HF32F series	250 Vac, 10 A	UL, VDE
(Alt.)	Song Chuan Precision Co Ltd	891P-1A-F-C	277 Vac, 25 A for UL; 250 Vac, 25 A for TUV	UL, TUV



기술문서 Technical Document

page: 11 / 15

안전인증번호: XU100121-22213A
(Certificate No)

접수번호: 20220118 - 0019
(Receipt No)

부품명(회로기호) Components(Part no.)	제조사(상표명) Manufacturer(Brand)	모델명(형식) Model(Type)	정격 또는 특성 (Technical Data)	인증규격 (Certification)
(Alt.)	XIAMEN HONGFA ELECTRO ACOUSTIC CO LTD	HF158F-V series	300 Vdc, 10 A for UL, VDE, CCC; 180 Vdc, 12 A for CCC/16 A for UL and VDE/; 277 Vac, 15 A for CCC/12 A for UL 250 Vac, 12 A for VDE	UL, VDE
(Alt.)	XIAMEN HONGFA ELECTRO ACOUSTIC CO LTD	HF32FV series	250 Vac, 10 A	UL, VDE
(Alt.)	XIAMEN HONGFA ELECTRO ACOUSTIC CO LTD	HF32FA series	250 Vac, 10 A	UL, VDE
(Alt.)	Good Sky Electric Co. Ltd.	GQ-SS/SH-112LM1	250 Vac, 10 A for TUV 125/250 Vac, 10 A for UL	UL, TUV
(Alt.)	Tary Technology Co., Ltd.	OJS-SH-112HMF	250 Vac, 10 A	UL, TUV
(Alt.)	XIAMEN HONGFA ELECTROACOUSTIC CO LTD	HF32F-G series; HF32FV-G series	250 Vac, 10 A	UL, VDE
Isolator IC (M11)	Texas Instruments Tucson Corp. Texas Instruments Inc. for CQC	ISO7841DW, ISO7841DWR	Minimum 5700 Vac, clearance 8.0 mm min., creepage 8.0 mm min., 125 °C	UL, VDE
(Alt.)	AD	ADuM241E0BR WZ	Minimum 5000 Vac, clearance 8.0 mm min., creepage 8.0 mm min., 125 °C	UL, VDE
(Alt.)	TWXAS INSTRUMENTS TUCSON CORP.	ISO7841 ISO7741	Minimum 5700 Vac Insulation thickness >0.4 mm, thermal cycling tested by VDE, external creepage=7.6 mm 125 °C	UL, VDE
(Alt.)	SILICON LABORATORIES	SI8641ED-B-IS	Minimum 5000 Vac Insulation thickness =0.4 mm, thermal cycling tested by FIMKO, external creepage=8.5 mm 100 °C	UL, VDE
Isolator IC (M6, M8)	Silicon Laboratories Inc	Si8233BD-D-IS	Minimum 5000 Vac, clearance 7.6 mm min., creepage 7.6 mm min., 125 °C	UL, VDE
(Alt.)	SILICON LABORATORIES	SI8233BB-D- IS1	Minimum 6000 Vac, clearance 8.5 mm min., creepage 8.5 mm min., 125 °C	UL, VDE



기술문서 Technical Document

page: 12 / 15

안전인증번호: XU100121-22213A
(Certificate No)

접수번호: 20220118 - 0019
(Receipt No)

부품명(회로기호) Components(Part no.)	제조사(상표명) Manufacturer (Brand)	모델명(형식) Model (Type)	정격 또는 특성 (Technical Data)	인증규격 (Certification)
(Alt.)	SILICON LABORATORIES	SI8233BB-D- ISR	Minimum 6000 Vac, clearance 8.5 mm min., creepage 8.5 mm min., 125 °C	UL, VDE
(Alt.)	SILICON LABORATORIES	SI8233BD-D- ISR	Minimum 6000 Vac, clearance 8.5 mm min., creepage 8.5 mm min., 125 °C	UL, VDE
(Alt.)	TEXAS INSTRUMENTS INCORPORATED	UCC21520AD WR	Minimum 8000 Vac, clearance 8 mm min., creepage mm min., 125 °C	UL, VDE
(Alt.)	TEXAS INSTRUMENTS INCORPORATED	UCC21520DW R	Minimum 8000 Vac, clearance 8 mm min., creepage mm min., 125 °C	UL, VDE
(Alt.)	TEXAS INSTRUMENTS INCORPORATED	UCC21540DW KR	Minimum 8000 Vac, clearance 8 mm min., creepage mm min., 125 °C	UL, VDE
(Alt.)	TEXAS INSTRUMENTS INCORPORATED	UCC21540DW R	Minimum 8000 Vac, clearance 8 mm min., creepage mm min., 125 °C	UL, VDE
(Alt.)	AD	ADuM4223BR WZ-RL	Minimum 6000 Vac, clearance 8 mm min., creepage mm min., 125 °C	UL, VDE
(Alt.)	AD	ADuM4223WB RWZ-RL	Minimum 6000 Vac, clearance 8 mm min., creepage mm min., 125 °C	UL, VDE
Choke (L1)	AcBel Polytech	21N16	125 °C min.	-
Choke (L4)	AcBel Polytech	21N17	125 °C min.	-
Choke (L5)	AcBel Polytech	21N03	130 °C min.	-
(Alt.)	MAGIC TECHNOLOGY	90480-9222I3	130 °C min.	-
Transformer (T5)	AcBel Polytech Inc.(API)	25P07	Class B	-
Transformer (T201)	AcBel Polytech Inc.(API)	25L60	Class B	-
Transformer (T401)	AcBel Polytech Inc.(API)	25M74	Class B	-
Fan	ASIA VITAL COMPONENTS CO LTD. For UL; Asia Vital Components Co., Ltd. For TUV	DBTD0428B2G(V), where (V) may be xxxx, where x may be A through Z, 0 through 9, "-", or blank.	12 V, 1.5 A, 31.27 CFM	-



기술문서 Technical Document

page: 13 / 15

안전인증번호: XU100121-22213A
(Certificate No)

접수번호: 20220118 - 0019
(Receipt No)

부품명(회로기호) Components(Part no.)	제조사(상표명) Manufacturer(Brand)	모델명(형식) Model(Type)	정격 또는 특성 (Technical Data)	인증규격 (Certification)
(Alt.)	NIDEC CORP for UL. Nidec Corporation Shiga Technical Center for TUV.	a40S12BGD5-ef, prefix "a" represents letters "V" or "W", suffix "e" represents number "00, 01, 02, 03, 04, 05, 06, 07, 08, 09, 10, 11, 51, 52, 53, 54, 55, 56, 57, 58, 59, 60 or 61", suffix "f" represents optional customer codes in alpha-numeric characters.	12 V, 1.1 A, 27.8 CFM	-
PCB	PLOTECH CO LTD	4	V-0, 130 ℃	UL
(Alt.)	EISO ENTERPRISE CO LTD	3/6	V-0, 130 ℃	UL
(Alt.)	ELEC&ELTEK CO LTD	E3330FL	V-0, 130 ℃	UL
(Alt.)	GOLD CIRCUIT ELECTRONICS LTD	D-V0A/T-V0A	V-0, 130 ℃	UL
(Alt.)	GOLD CIRCUIT ELECTRONICS LTD	H	V-0, 130 ℃	UL
(Alt.)	GUANG DONG ELLINGTON ELECTRONICS TECHNOLOGY CO LTD	ET856/ET866/ET566/ET866A	V-0, 130 ℃	UL
(Alt.)	NEW ERA ELECTRONICS CO LTD	TC/2M	V-0, 130 ℃	UL
(Alt.)	PALWONN ELECTRONICS (SHENZHEN) CO LTD	M2/M3/M5/M8	V-0, 130 ℃	UL
(Alt.)	PLOTECH CO LTD	5/6	V-0, 130 ℃	UL
(Alt.)	REMAPP INDUSTRIAL CO LTD	RM04TG	V-0, 130 ℃	UL
(Alt.)	SHENZHEN KINWONG ELECTRONIC CO LTD	8B/8F	V-0, 130 ℃	UL

[서식 CP401-18-00]



기술문서 Technical Document

page: 14 / 15

안전인증번호: XU100121-22213A
(Certificate No)

접수번호: 20220118 - 0019
(Receipt No)

부품명(회로기호) Components(Part no.)	제조사(상표명) Manufacturer(Brand)	모델명(형식) Model(Type)	정격 또는 특성 (Technical Data)	인증규격 (Certification)
(Alt.)	TREASURE ELECTRONIC TECHNOLOGY (SHENZHEN) LTD	T-M1	V-0, 130 ℃	UL
(Alt.)	PALWONN ELECTRONICS (SHENZHEN) CO LTD	M6	V-0, 105 ℃	UL
(Alt.)	APCB Inc (Competitor Printed Circuit Board)	77	V-0, 130 ℃	UL
(Alt.)	SUNTAK MULTILAYER PCB CO LTD	STM-4, STM-6	V-0, 130 ℃	UL
(Alt.)	ELEC&ELTEK CO LTD	E3330GM	V-0, 130 ℃	UL
(Alt.)	PALWONN ELECTRONICS (SHENZHEN) CO LTD	M7	V-0, 130 ℃	UL
(Alt.)	Multek Hong Kong Ltd	890/890K	V-0, 130 ℃	UL
Metal Chiassis	Interchangeable	Interchangeable	Metallic, thickness 0.8 mm min.	-
PCB (other than PCB1)	Interchangeable	Interchangeable	V-1 or better, 105 ℃	UL



기술문서 Technical Document

page: 15 / 15

안전인증번호: XU100121-22213A
(Certificate No)

접수번호: 20220118 - 0019
(Receipt No)

3. 전기용품안전인증의 변경현황(Status of Certificate Revisions)

일자(Date)	발급현황(Status of issues)
	변경내용(Modification of Contents)
2022/02/03	안전확인(기본+파생)

4. 기타(Carefully Informed Note)

- 1) 안전관리부품 및 재질목록에 기재된 사항은 안전에 직접적인 영향을 주는 부분이므로 내용을 변경 또는 복수등재를 원하는 경우 안전인증변경신청 또는 안전확인변경신고를 하여야 합니다. 안전인증변경신청 또는 안전확인변경신고를 하지 않고 임의로 변경하는 경우에는 전기용품 및 생활용품 안전관리법에 따라 행정조치 될 수 있습니다.

The certificate holder should apply for a revision of the certificate if the registered critical components are to be changed, modified or alternated. Should the contents of Certificate are altered without the application for the modification, the administrative measures can occur according to the Electrical Appliances and Consumer Products Safety Control Act.

- 2) 공장주소(전화번호포함), 대표자, 상호 및 부품변경, 신고인정보 등 안전인증 또는 안전확인신고의 내용이 변경되었을 때, 안전인증변경신청 또는 안전확인변경신고를 하지 않을 경우에는 전기용품 및 생활용품 안전관리법에 따라 행정조치 될 수 있습니다.

Should a factory address, president name, manufacturer name and critical component are altered without the application for the modification, the administrative measures can occur according to the Electrical Appliances and Customer Products Safety Control Act.

- 3) 조건부 인증사항 (Conditional certification items):













기술문서붙임자료

안전인증번호: XU100121-22213A

접수번호: 20220118-0019

No.1 KC Label

 <p>MODEL型号(型號)FSG032 开关电源(交換式電源供應器)</p> <p>OPTION : XXXX REV: XXX FRU: XXXXXXXXXXXX</p> <p>AC INPUT 交流輸入(交流輸入): 100-127V~, 50/60Hz, 10A MAX 200-240V~, 50/60Hz, 5A MAX</p> <p>DC INPUT 直流輸入(直流輸入): 240VDC === 5A MAX</p> <p>DC OUTPUT 直流輸出(直流輸出): +12V === 65A +12Vsb === 2A</p> <p>TOTAL 800W MAX最大總功率(最大總功率)800W MADE IN CHINA中國製造(中國製造)</p> <p>FC This device complies with Part 15 of the FCC Rules. Operation is subject to the following two conditions: (1) This device may not cause harmful interference, and (2) this device must accept any interference received, including interference that may cause undesired operation.</p>		 R33567 RoHS	 E131875(B)	
 XXXXXXXXXXXXXXXXXXXX NNNNNNNXYWWSSSSSS	 AcBel Polytech (UK) Limited 9 Royal Crescent Glasgow G3 7SP		 XU100121-22213A R-R-API-FSG032 원주 테크놀로지전자(주) 111, Narae-ro, AcBel Electronics(DongGuan)Co., Ltd A/S - 070-7094-0620	 Type Approved Safety Regular Production Surveillance www.tuv.com ID 141981428
				<p>警告使用者: 此為甲類資訊技術設備, 於居住環境中使用時, 可能會造成射頻擾動, 在此種情況下, 使用者會被要求採取某些適當的對策。</p> <p>警告 此為A級產品, 在生活環境中, 該產品可能會造成無線電干擾, 在這種情況下, 可能需要用戶對干擾採取切實可行的措施。</p>

No.2 External View

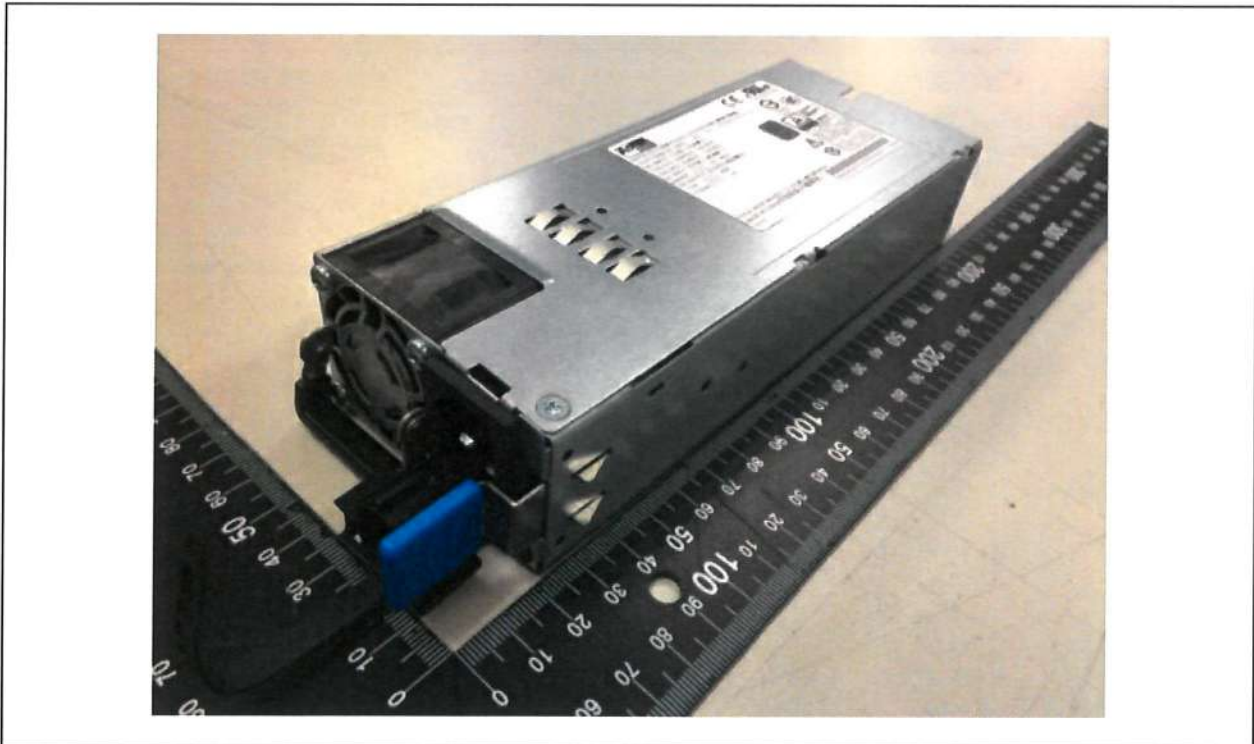

기술문서붙임자료

안전인증번호: XU100121-22213A

접수번호: 20220118-0019

No.3 External View



No.4 Internal View

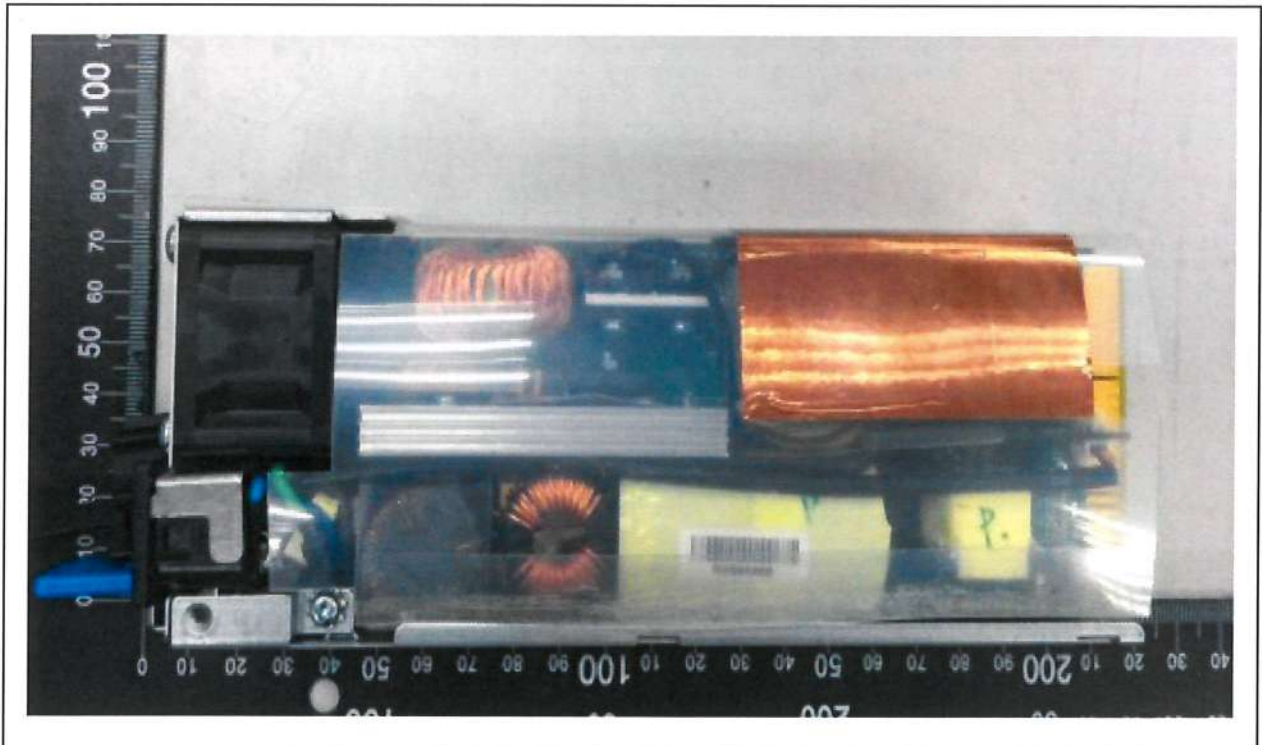

기술문서붙임자료

안전인증번호: XU100121-22213A

접수번호: 20220118-0019

No.5 Internal View



No.6 PCB View

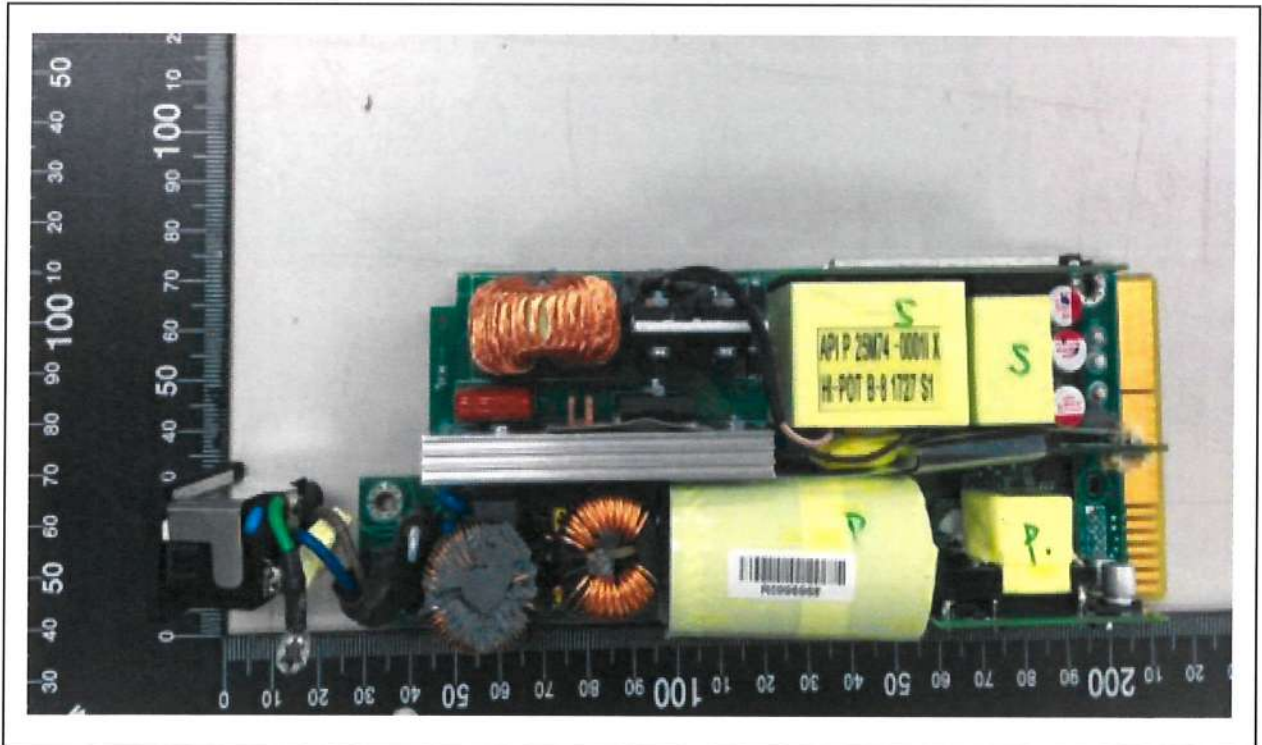

기술문서붙임자료

안전인증번호: XU100121-22213A

접수번호: 20220118-0019

No.7 PCB View



No.8 PCB View

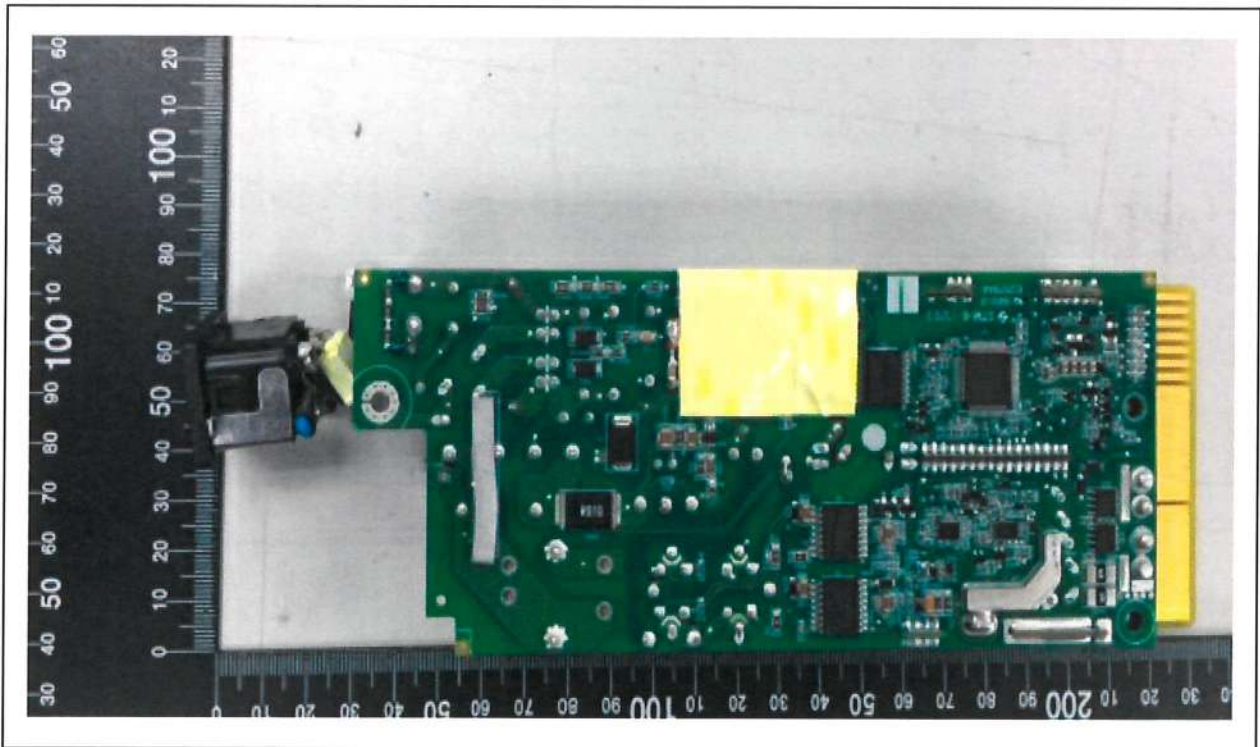

기술문서붙임자료

안전인증번호: XU100121-22213A

접수번호: 20220118-0019

No.9 PCB View

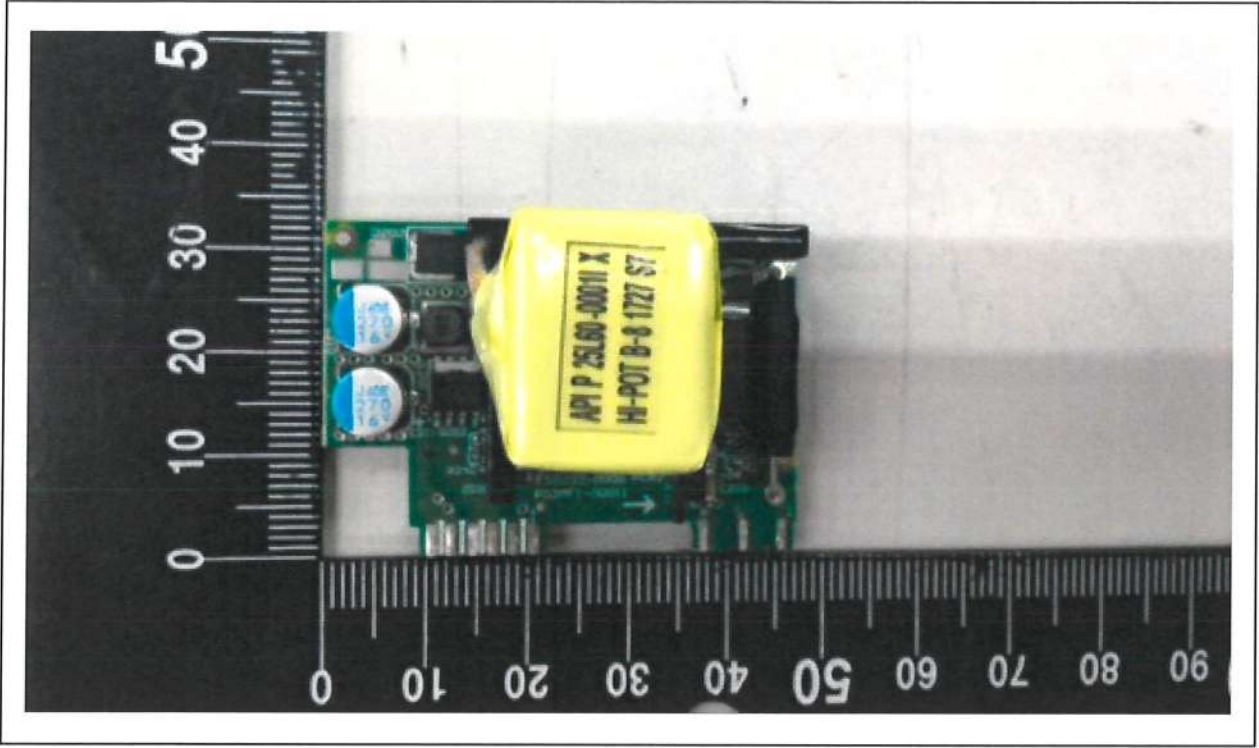

No.10 PCB View

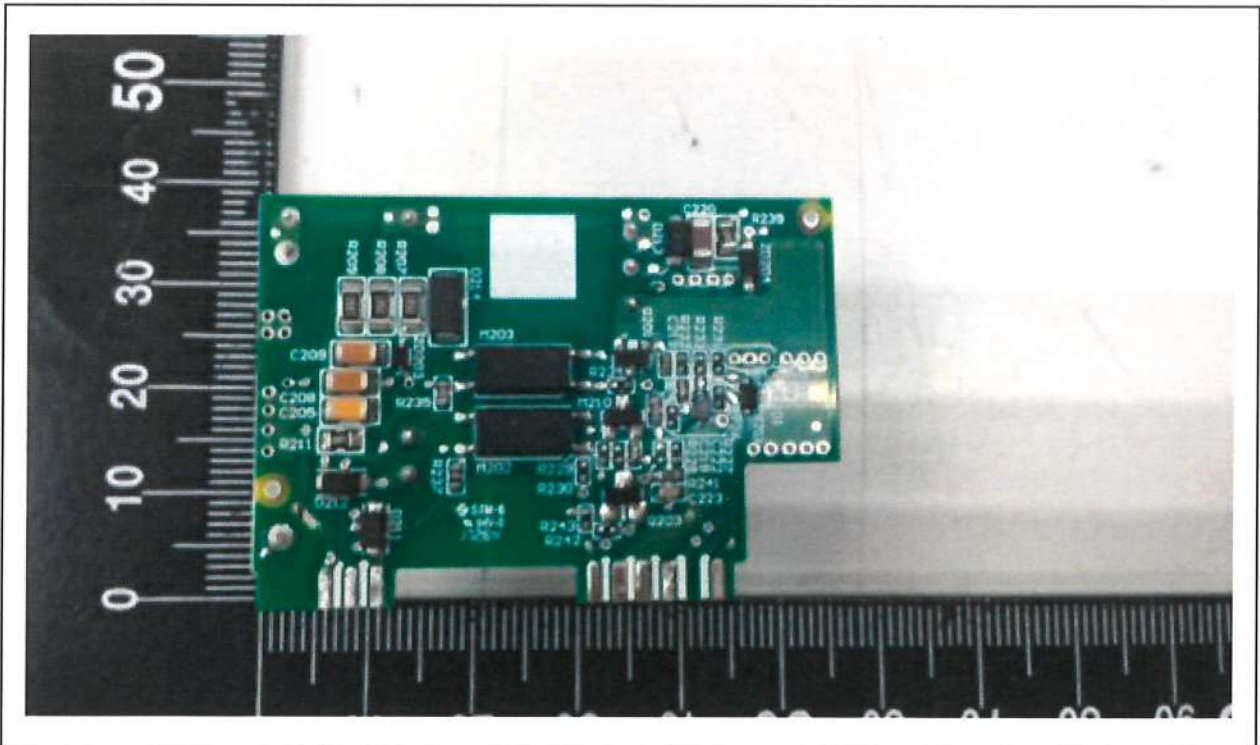

기술문서붙임자료

안전인증번호: XU100121-22213A

접수번호: 20220118-0019

No.11 PCB View

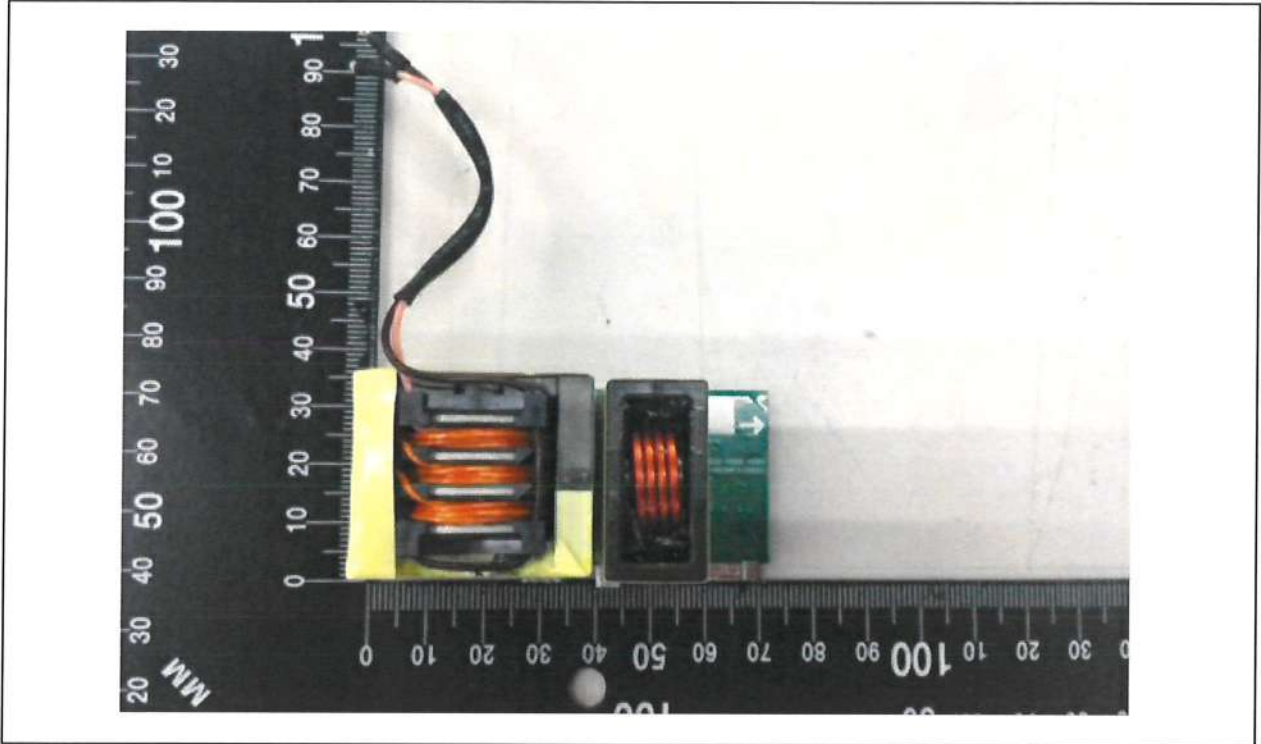

No.12 PCB View

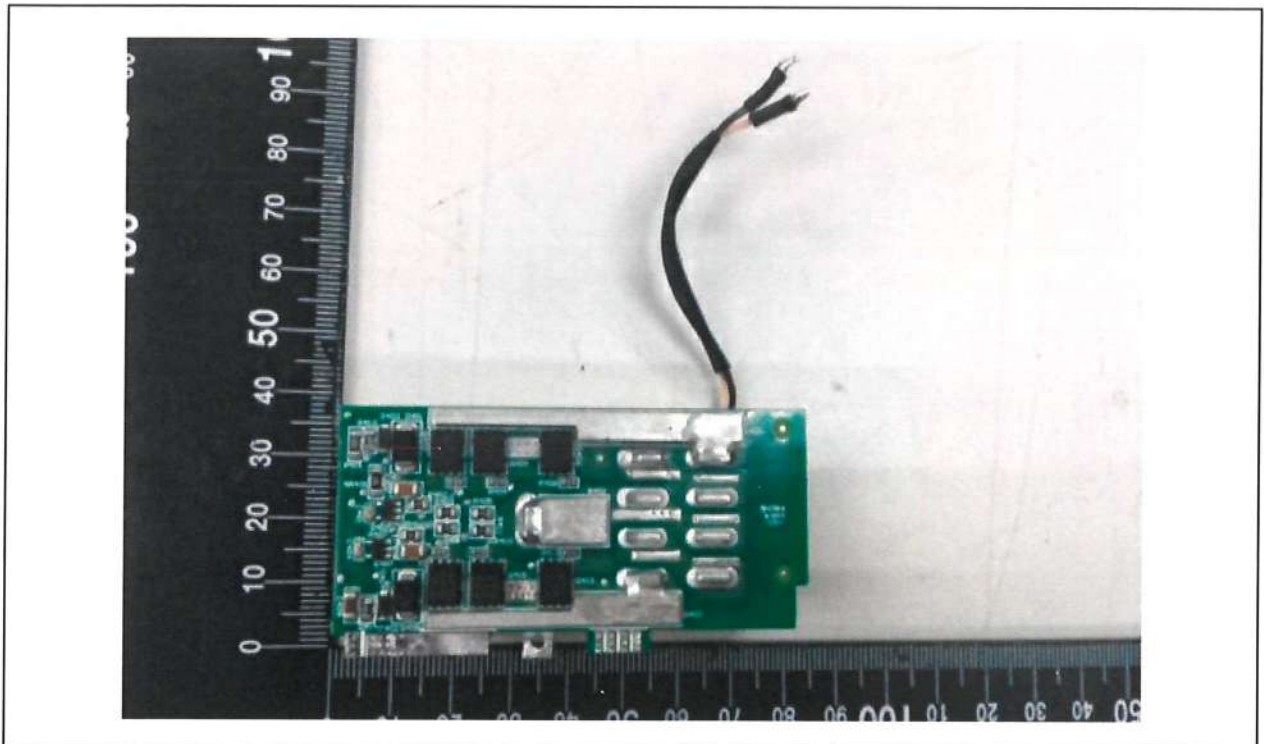

Declaration of Conformity

(إعلان المطابقة)

For the following equipment (للمعدات التالية) :

Product (المنتج) :	FSG032
Type Designation (نوع تعيين) :	Switching Power Supply
Trademark (علامة تجارية) :	AcBel
Manufacturer's Name (اسم الشركة المصنعة) :	ACBEL POLYTECH INC
Address (عنوان الشركة المصنعة) :	No. 159, Sec. 3, Danjin Rd., Tamsui Dist., New Taipei City 251, Taiwan

Is herewith confirmed to comply with the following legal requirements sold in the Morocco.

- NM EN 62368 1:2018 Equipements des technologies de l'audio/video, de l'information et de la communication Partie 1 : Exigences de securite
- NM EN 55022:2015 Appareils de traitement de l'information - Caractéristiques des perturbations radioélectriques - Limites et méthodes de mesure ;
EN 61000-3-2:2019 ;
EN 61000-3-3:2013+A11 :2019
- NM EN 55035:2018 Compatibilite electromagnetique des equipements multimedia
Exigences d'immunité
- NM EN 61000 3 2:2015 Compatibilité électromagnétique (CEM) - Partie 3 2 : Limites -
Limites pour les émissions de courant harmonique (courant appelé
par les appareils ≤ 16 A par phase)
- NM EN 61000 3 3:2015 Compatibilité électromagnétique (CEM) - Partie 3 3 : Limites -
Limitation des variations de tension, des fluctuations de tension et
du papillotement dans les réseaux publics d'alimentation basse
tension, pour les matériels ayant un courant assigné ≤ 16 A par
phase et non soumis à un raccordement conditionnel

Responsible for making this declaration is the (المسؤولة عن صنع هذا الإعلان هو) :

Manufacturer (الشركة المصنعة)

Name (اسم) : Paul Huang
Position (موضع) : Safety Supervisor (مشرف السلامة)

Taipei (تايبيه) , Taiwan (تايوان)
Place (مكان)

2021-12-30
Date (تاريخ)

Legal Signature
(التوقيع القانوني)

ATTESTATION OF CONFORMITY



Attestation No.:	21120012
Applicant / Holder:	AcBel Polytech Inc.
Address:	No. 159, Sec. 3, Danjin Rd., Tamsui Dist., New Taipei City 251, Taiwan
Trade Mark:	Acbel
Product / Test Item:	Switching Power Supply
Model / Type Reference:	FSG032

The submitted sample(s) have been tested with the following standard(s) and found to be in compliance with the essential requirements:

Standard(s)

Applicable to ANSI C63.4 – 2014

(The Information Technology Equipment)

That this product has been assessed against the following Applicable Standards

CISPR PUB. 22, FCC Part 15 Subpart B Class A

The measurements shown in this test report may issue a Supplier's Declaration of Conformity and apply the FCC mark.



Kero Kuo / EMC & RF Manager
2021-12-23

Cerpass Technology Corporation

■ Cerpass Technology Corporation Test Laboratory
No.10, Ln. 2, Lianfu St., Luzhu Dist., Taoyuan City 33848, Taiwan



FCC SDOC TEST REPORT

Equipment : Switching Power Supply

Model No. : FSG032

Trade Name : AcBel

Applicant : AcBel Polytech Inc.

Address : No. 159, Sec. 3, Danjin Rd., Tamsui Dist.,
New Taipei City 251, Taiwan

Standard : ANSI C63.4
FCC Part 15 Subpart B

HEREBY CERTIFY THAT :

The sample was received on : Dec. 02, 2021

The testing was carried out on : Dec. 20, 2021

The test result refers exclusively to the test presented test model / sample.

Without written approval of CerpPASS Technology Corp., the test report shall not be reproduced except in full.

Approved by:

Kero Kuo / EMC/RF Manager





Contents

Summary of Test Results	4
1. Applicable Standards	4
2. General Description	4
2.1. Product Details.....	4
2.2. Accessories.....	4
3. Test Configuration of Equipment under Test	5
3.1. Test Software.....	5
3.2. Test Manner.....	5
3.3. Description of Support Unit.....	5
3.4. General Information of Test.....	5
4. Test of Conducted Emission	6
4.1. Test Limit.....	6
4.2. Test Procedures.....	6
4.3. Typical Test Setup.....	7
4.4. Test Result and Data of Power Port.....	8
4.5. Test Photographs of Power Port.....	10
5. Test of Radiated Emission	11
5.1. Test Limit.....	11
5.2. Test Procedures.....	12
5.3. Typical Test Setup.....	12
5.4. Test Result and Data (30MHz ~ 1GHz).....	14
5.5. Test Photographs (30MHz ~ 1GHz).....	16
6. Measurement Uncertainty	17
7. List of Measuring Equipment	17



History of this test report

Report No.	Issue Date	Description	Version
21120012-TEFV01	Dec. 23, 2021	Original	A



Summary of Test Results

1. Applicable Standards

The measurements shown in this test report were made in accordance with the procedures given in ANSI C63.4 – 2014 and the energy emitted by this equipment was passed Part 2, Part 15, CISPR PUB. 22.

The energy emitted by this equipment was passed both Radiated and Conducted Emissions Class **A** limits.

Test Item	Normative References	Test Result
Conducted Emission	ANSI C63.4-2014, FCC Part 15 Subpart B	PASS
Radiation Emission	ANSI C63.4-2014, FCC Part 15 Subpart B	PASS

Note*: Pass criterion is defined by the applicant. The test report is to follow the applicant specification.

The lab has reduced the uncertainty risk factor from test equipment, environment and staff technicians which according to the standard on contract. Therefore, the test result will only be determined by standard requirement.

2. General Description

2.1. Product Details

Input: (1) 100-127V~, 50/60Hz, 10A MAX
200-240V~, 50/60Hz, 5A MAX
240VDC, 5A MAX
(2) 200-240V~, 50/60Hz, 5A MAX
240VDC, 5A MAX
Output: +12V/65A, +12Vsb/2A
Total Power 800W MAX.

2.2. Accessories

N/A



3. Test Configuration of Equipment under Test

3.1. Test Software

N/A

3.2. Test Manner

- During testing, the interface cables and equipment positions were varied according to ANSI C63.4-2014.
- The test modes of EMI test as follow:

Conducted Emission for AC main power and Radiation Emissions	
Test Mode 1	AC 120V, Full Load in Case
Test Mode 2	DC 240V, Full Load in Case
Test Mode 3	AC 240V, Full Load in Case
caused "Test Mode 1" generated the worst case, these were reported as the final data.	

- The maximum operating frequency is 70kHz below 108MHz, the test frequency range is from 30MHz to 1GHz.

3.3. Description of Support Unit

No	Device	Manufacturer	Model No.	Description
1	Case	N/A	N/A	N/A
2	Load	N/A	N/A	N/A

3.4. General Information of Test

Test Site	CerpPASS Technology Corporation Test Laboratory Address: No.10, Ln. 2, Lianfu St., Luzhu Dist., Taoyuan City 33848, Taiwan (R.O.C.) Tel:+886-3-3226-888 Fax:+886-3-3226-881
	<input checked="" type="checkbox"/> Conducted emission test (CON01-NK) <input type="checkbox"/> Conducted emission test (CON02-NK) <input checked="" type="checkbox"/> Radiated emission test (10M01-NK) <input type="checkbox"/> Radiated emission test (3M01-NK) <input type="checkbox"/> Radiated emission test (3M02-NK) <input type="checkbox"/> Radiated disturbance above 1GHz (10M01-NK) <input type="checkbox"/> Radiated disturbance above 1GHz (3M01-NK) <input type="checkbox"/> Radiated disturbance above 1GHz (3M02-NK)
	TW1079, TW1439
Frequency Range Investigated:	Conducted: from 150 kHz to 30 MHz Radiation: from 30 MHz to 1,000 MHz
Test Distance :	The test distance of radiated emission below 1GHz from antenna to EUT is 10 M. The test distance of radiated emission above 1GHz from antenna to EUT is 3 M.



4. Test of Conducted Emission

4.1. Test Limit

Conducted Emissions were measured from 150 kHz to 30 MHz with a bandwidth of 9 KHz, according to the methods defined in ANSI C63.4-2014. The EUT was placed on a nonmetallic stand in a shielded room 0.8 meters above the ground plane. The interface cables and equipment positioning were varied within limits of reasonable applications to determine the position produced maximum conducted emissions.

Table 1 Conducted Emission Limits (dB μ V):

Frequency range (MHz)	Class A Equipment		Class B Equipment	
	Quasi Peak	Average	Quasi Peak	Average
0.15 to 0.50	79	66	66 to 56*	56 to 46*
0.50 to 5	73	60	56	46
5. to 30.	73	60	60	50

*The limit decreases linearly with the logarithm of the frequency in the range 0.15 MHz to 0.5MHz.

4.2. Test Procedures

- The EUT was placed 0.4 meter from the conducting wall of the shielding room was kept at least 80 centimeters from any other grounded conducting surface.
- Connect EUT to the power mains through a line impedance stabilization network (LISN).
- All the support units are connecting to the other LISN.
- The LISN provides 50 ohm coupling impedance for the measuring instrument.
- The FCC states that a 50 ohm, 50 micro-Henry LISN should be used.
- Both sides of AC line were checked for maximum conducted interference.
- The frequency range from 150 kHz to 30 MHz was searched.
- Set the test-receiver system to Peak Detect Function and Specified Bandwidth with Maximum Hold Mode.

4.3. Typical Test Setup

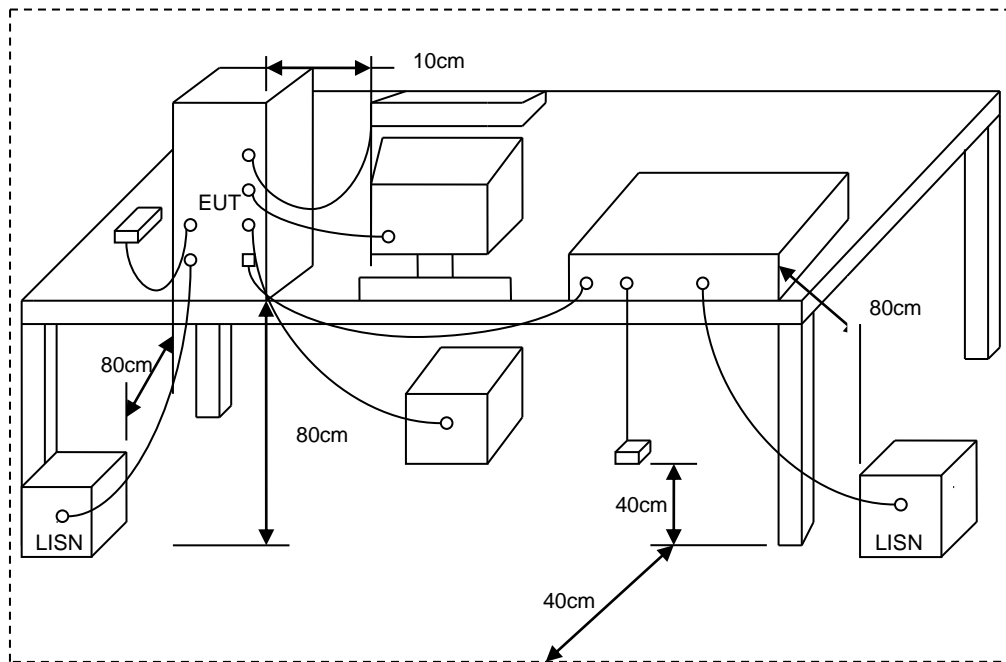



4.4. Test Result and Data of Power Port

Test Mode	Mode 1	Pol/Phase	LINE
Test Frequency	0.15 MHz ~ 30 MHz	Test Voltage	AC 120V
Test Date	Dec. 20, 2021	Test Engineer	Jack
Temperature	20°C	Relative Humidity	50%

Note : Level = Reading + Factor
 Margin = Level – Limit
 Factor= (LISN or PLC or Current Probe) Factor + Cable Loss + Attenuator

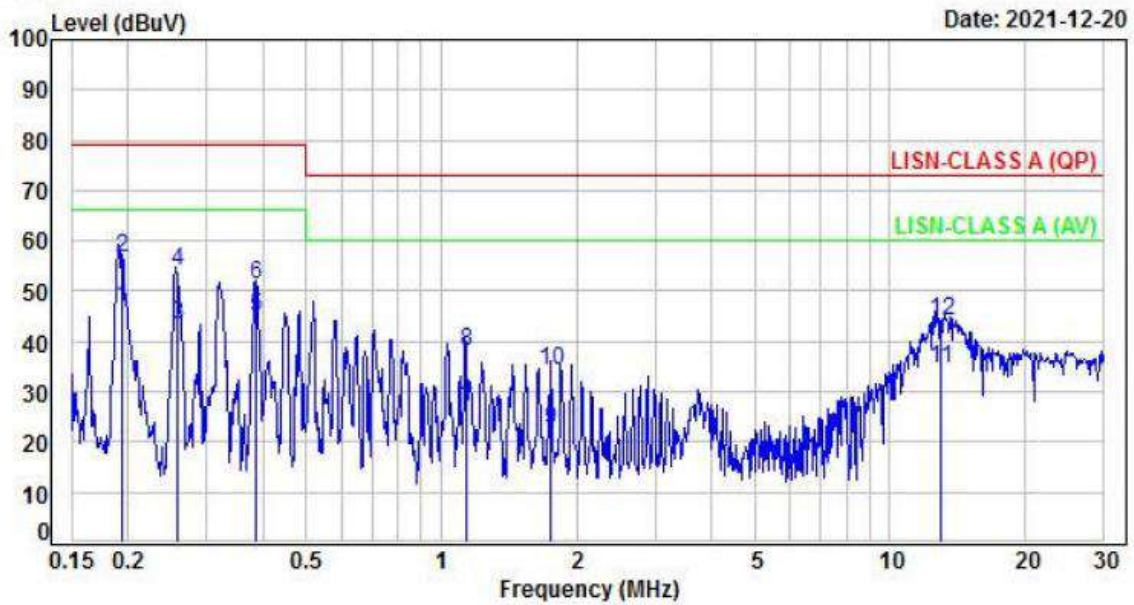

No.	Frequency (MHz)	Factor (dB)	Reading (dBuV)	Level (dBuV)	Limit (dBuV)	Margin (dB)	Detector	P/F
1	0.19	9.97	36.65	46.62	66.00	-19.38	Average	P
2	0.19	9.97	46.76	56.73	79.00	-22.27	QP	P
3	0.26	9.97	33.37	43.34	66.00	-22.66	Average	P
4	0.26	9.97	44.02	53.99	79.00	-25.01	QP	P
5	0.39	9.98	35.05	45.03	66.00	-20.97	Average	P
6	0.39	9.98	41.22	51.20	79.00	-27.80	QP	P
7	1.13	10.06	16.30	26.36	60.00	-33.64	Average	P
8	1.13	10.06	28.03	38.09	73.00	-34.91	QP	P
9	1.75	10.11	12.27	22.38	60.00	-37.62	Average	P
10	1.75	10.11	24.26	34.37	73.00	-38.63	QP	P
11	12.95	10.51	24.10	34.61	60.00	-25.39	Average	P
12	12.95	10.51	33.70	44.21	73.00	-28.79	QP	P



Test Mode	Mode 1	Pol/Phase	NEUTRAL
Test Frequency	0.15 MHz ~ 30 MHz	Test Voltage	AC 120V
Test Date	Dec. 20, 2021	Test Engineer	Jack
Temperature	20°C	Relative Humidity	50%

Note : Level = Reading + Factor
 Margin = Level – Limit
 Factor= (LISN or PLC or Current Probe) Factor + Cable Loss + Attenuator

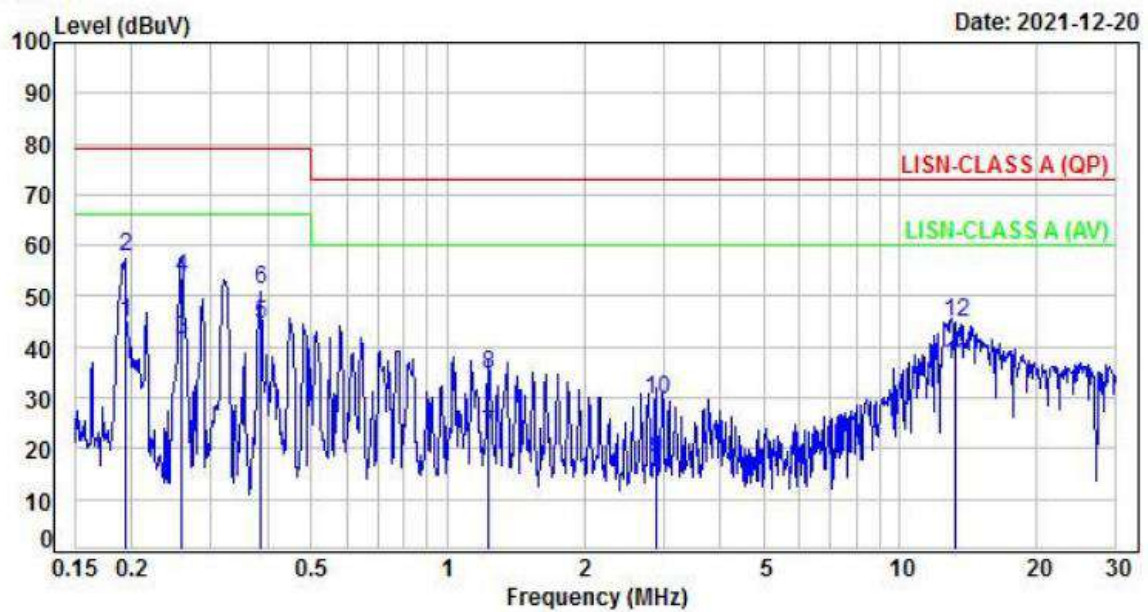

No.	Frequency (MHz)	Factor (dB)	Reading (dBuV)	Level (dBuV)	Limit (dBuV)	Margin (dB)	Detector	P/F
1	0.19	9.97	34.83	44.80	66.00	-21.20	Average	P
2	0.19	9.97	47.85	57.82	79.00	-21.18	QP	P
3	0.26	9.97	31.55	41.52	66.00	-24.48	Average	P
4	0.26	9.97	43.76	53.73	79.00	-25.27	QP	P
5	0.39	9.98	34.51	44.49	66.00	-21.51	Average	P
6	0.39	9.98	41.44	51.42	79.00	-27.58	QP	P
7	1.23	10.06	12.67	22.73	60.00	-37.27	Average	P
8	1.23	10.06	24.58	34.64	73.00	-38.36	QP	P
9	2.88	10.14	7.64	17.78	60.00	-42.22	Average	P
10	2.88	10.14	19.43	29.57	73.00	-43.43	QP	P
11	13.21	10.50	25.90	36.40	60.00	-23.60	Average	P
12	13.21	10.50	34.29	44.79	73.00	-28.21	QP	P



4.5. Test Photographs of Power Port

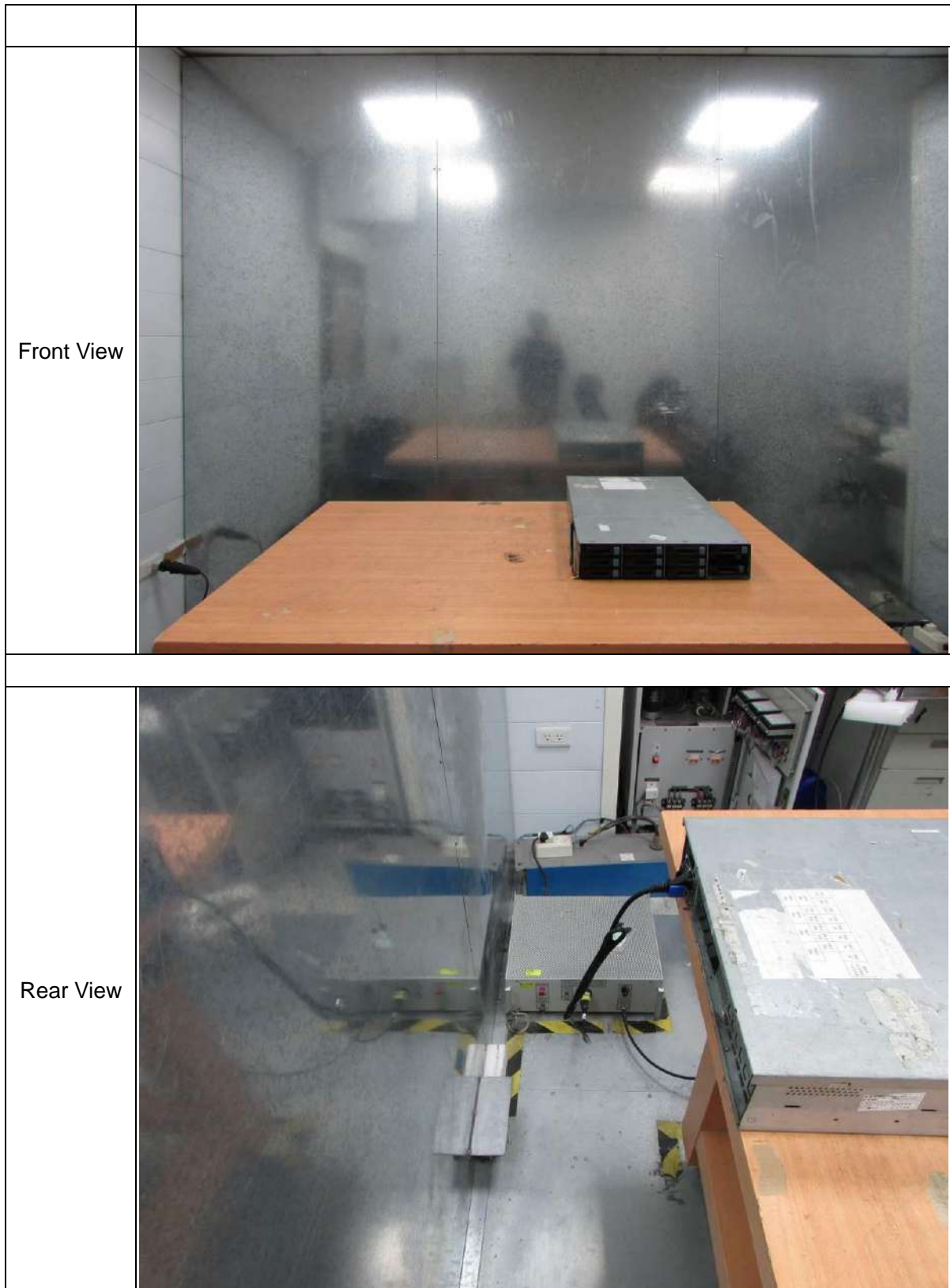



5. Test of Radiated Emission

5.1. Test Limit

Radiated emissions from 30 MHz to 1,000 MHz were measured with a bandwidth of 120 kHz according to the methods defines in ANSI C63.4-2014. The EUT was placed on a nonmetallic stand in the open-field site, 0.8 meter above the ground plane. The interface cables and equipment positions were varied within limits of reasonable applications to determine the positions producing maximum radiated emissions.

For unintentional device, according to § 15.109(a), except for Class A digital devices, the field strength of radiated emissions from unintentional radiators at a distance of 3 meters shall not exceed the following values:

Table 1 – Frequency below 1GHz

Frequency (MHz)	Distance Meters	Class A(dBµV/m)	Class B(dBµV/m)t
30-230	10	40	30
230-1000	10	47	37

Note: The limit for radiated test was performed according to CISPR 22, which was specified in FCC PART 15B 15.109(g). Also the limits of ICES-003 and CISPR 22 are the same.

Table 2 –Frequency above 1GHz

Frequency (MHz)	Distance Meters	Class A(dBµV/m)		Class B(dBµV/m)t	
		Peak	Average	Peak	Average
Above 1GHz	3	80.0	60.0	74.0	54.0

Note: (1) The lower limit shall apply at the transition frequencies.

(2) Emission level (dBµV/m)= 20 log Emission level(µV/m)

(3) All emission from a class A/B digital device or system, including any network of conductors and apparatus connected thereto, shall not exceed the level of field strengths specified above.

Table 3 –Frequency range of radiated measurement (for unintentional radiators)

Highest frequency generated or Upper frequency of measurement used in the device or on which the device operates or tunes(MHz)	Range(MHz)
Below 1.705	30
1.705-108	1000
108-500	2000
500-1000	5000
Above 1000	5th harmonic of the highest frequency or 40GHz, which is lower

5.2. Test Procedures

- a. The EUT was placed on a rotatable table top 0.8 meter above ground.
- b. The EUT was set 10 meters from the interference receiving antenna which was mounted on the top of a variable height antenna tower.
- c. The table was rotated 360 degrees to determine the position of the highest radiation.
- d. The antenna is a half wave dipole and its height is varied between one meter and four meters above ground to find the maximum value of the field strength both horizontal polarization and vertical polarization of the antenna are set to make the measurement.
- e. For each suspected emission the EUT was arranged to its worst case and then tune the antenna tower (from 1 M to 4 M) and turn table (from 0 degree to 360 degrees) to find the maximum reading.
- f. Set the test-receiver system to Peak Detect Function and specified bandwidth with Maximum Hold Mode.
- g. If the emission level of the EUT in peak mode was 6 dB lower than the limit specified, then testing will be stopped and peak values of EUT will be reported, otherwise, the emissions which do not have 6 dB margin will be repeated one by one using the quasi-peak method and reported.

5.3. Typical Test Setup

Below 1GHz Test Setup

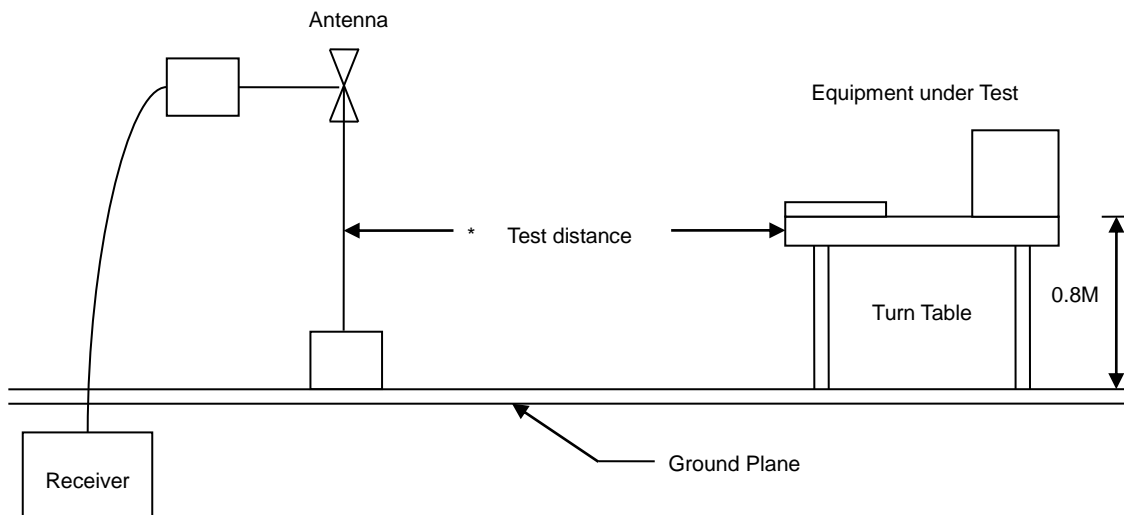



Above 1GHz Test Setup

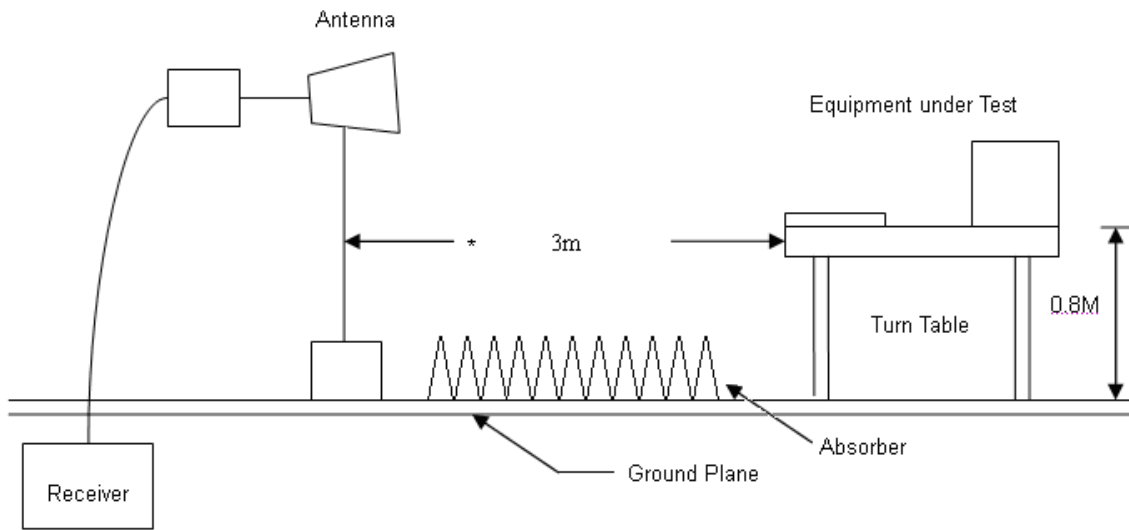



5.4. Test Result and Data (30MHz ~ 1GHz)

Test Mode	Mode 1	Pol/Phase	VERTICAL
Test Frequency	30 MHz ~ 1 GHz	Test Voltage	AC 120V
Test Date	Dec. 20, 2021	Test Engineer	Tim
Temperature	20°C	Relative Humidity	57%

Note : Level = Reading + Factor
 Margin = Level - Limit
 Factor = Antenna Factor + Cable Loss - Amplifier Factor

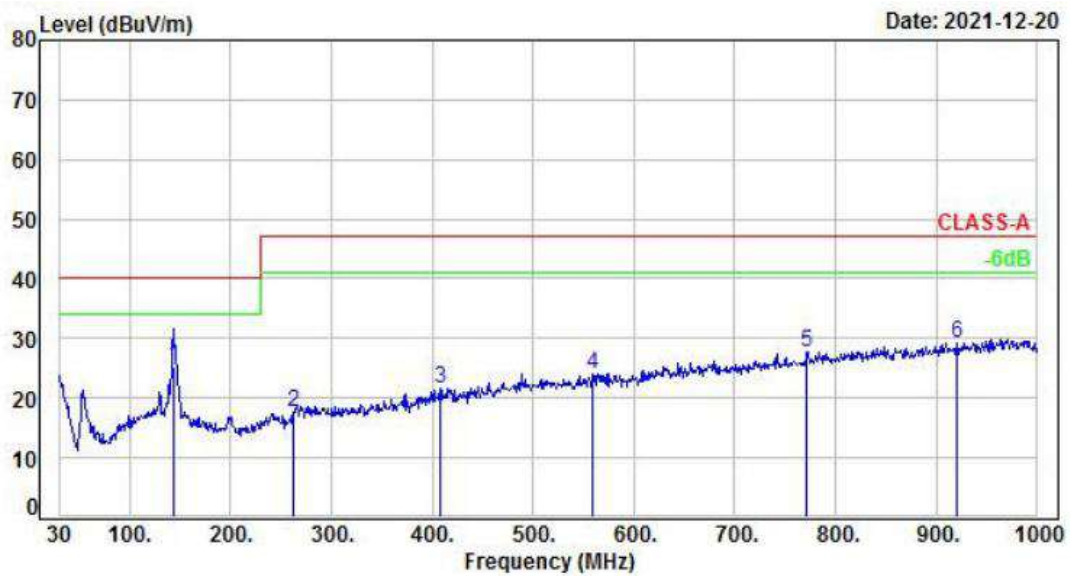

No.	Frequency (MHz)	Factor (dB/m)	Reading (dBuV)	Level (dBuV/m)	Limit (dBuV/m)	Margin (dB)	Detector	Height (cm)	Azimuth (deg)	P/F
1	143.49	-10.55	35.70	25.15	40.00	-14.85	QP	200	111	P
2	262.80	-10.22	27.92	17.70	47.00	-29.30	Peak	100	246	P
3	407.33	-6.38	27.92	21.54	47.00	-25.46	Peak	200	160	P
4	559.62	-3.09	27.16	24.07	47.00	-22.93	Peak	400	68	P
5	772.05	0.27	27.28	27.55	47.00	-19.45	Peak	400	178	P
6	920.46	2.31	26.78	29.09	47.00	-17.91	Peak	100	239	P



Test Mode	Mode 1	Pol/Phase	HORIZONTAL
Test Frequency	30 MHz ~ 1 GHz	Test Voltage	AC 120V
Test Date	Dec. 20, 2021	Test Engineer	Tim
Temperature	20°C	Relative Humidity	57%

Note : Level = Reading + Factor
 Margin = Level – Limit
 Factor = Antenna Factor + Cable Loss – Amplifier Factor

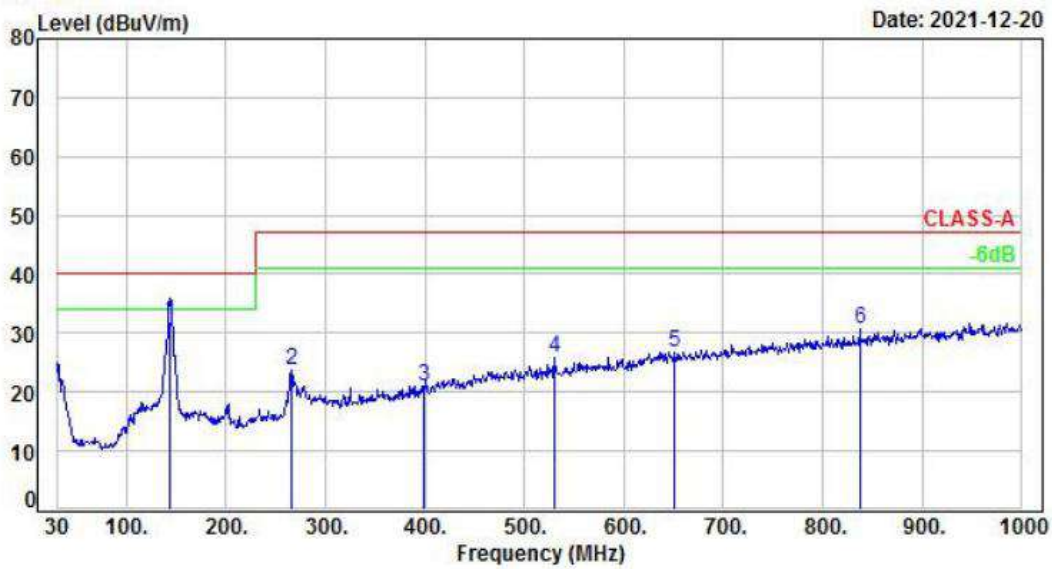

No.	Frequency (MHz)	Factor (dB/m)	Reading (dBuV)	Level (dBuV/m)	Limit (dBuV/m)	Margin (dB)	Detector	Height (cm)	Azimuth (deg)	P/F
1	143.49	-9.65	41.71	32.06	40.00	-7.94	QP	400	187	P
2	265.71	-8.71	32.48	23.77	47.00	-23.23	Peak	400	162	P
3	398.60	-5.15	26.29	21.14	47.00	-25.86	Peak	100	219	P
4	530.52	-1.83	27.84	26.01	47.00	-20.99	Peak	100	87	P
5	650.80	0.86	26.03	26.89	47.00	-20.11	Peak	100	322	P
6	837.04	4.18	26.46	30.64	47.00	-16.36	Peak	400	261	P



5.5. Test Photographs (30MHz ~ 1GHz)

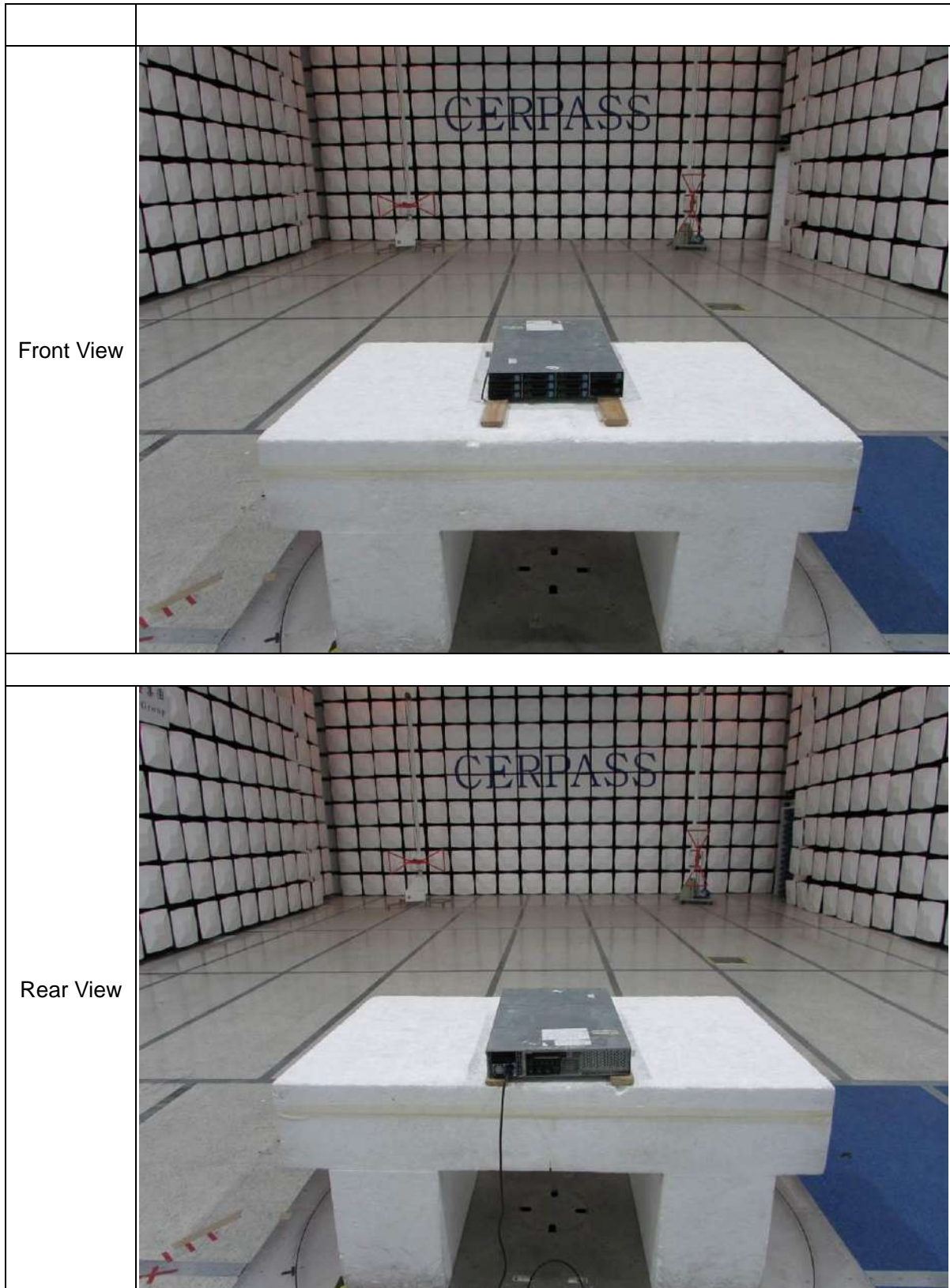



6. Measurement Uncertainty

Measurement Item	Measurement Frequency	Polarization	Uncertainty
Conducted Emission	150 kHz ~ 30 MHz	Line / Neutral	±3.12dB
Radiated Emission	30 MHz ~ 1,000 MHz	Vertical / Horizontal	±4.53dB
	1,000 MHz ~ 6,000 MHz	Vertical / Horizontal	±4.93dB
	6,000 MHz ~ 18,000 MHz	Vertical / Horizontal	±5.11dB

The measurement uncertainty will be considered, when test result margin to the limit.

ISO/IEC 17025 requires that an estimate of the measurement uncertainties associated with the emissions test results be included in the report. The measurement uncertainties given below are based on a 95% confidence level (based on a coverage factor (k=2)).

7. List of Measuring Equipment

Conducted Emission (Test date: 2021/12/20)					
Instrument	Manufacturer	Model No.	Serial No.	Calibration Date	Valid Date
EMI Receiver	R&S	ESCI	101200	2021/08/30	2022/08/29
LISN	Schwarzbeck	NSLK 8127	8127-568	2021/06/02	2022/06/01
Pulse Limiter	R&S	ESH3-Z2	101934	2021/03/10	2022/03/09
Cable-6m (9kHz~300MHz)	N/A	CFD300-NL	N/A	2021/03/15	2022/03/14
Software	AUDIX	E3	Version: V8.2014-8-6	N/A	N/A

Radiated Emission below 1GHz (Test date: 2021/12/20)					
Instrument	Manufacturer	Model No.	Serial No.	Calibration Date	Valid Date
Bilog Antenna(V)	Sunol	JB1	A020514-1	2021/03/18	2022/03/18
Bilog Antenna(H)	Sunol	JB1	A020514-2	2021/05/06	2022/05/05
EMI Receiver(V)	R&S	ESCI	100443	2021/05/20	2022/05/19
EMI Receiver(H)	R&S	ESCI	101402	2021/03/12	2022/03/11
Preamplifier(V)	EM Electronics corp.	EM330	60644	2021/09/17	2022/09/16
Preamplifier(H)	EM Electronics corp.	EM330	60610	2021/03/09	2022/03/08
Cable-16m (30MHz-1GHz) (H)	HUBER SUHNER	RG-214	01110M	2021/03/26	2022/03/25
Cable-4m (30MHz-1GHz) (H)	HUBER SUHNER	RG-214	02951M	2021/03/26	2022/03/25
Cable-1m (30MHz-1GHz) (H)	HUBER SUHNER	RG-214	01098M	2021/03/26	2022/03/25
Cable-10m (30MHz-1GHz) (V)	HUBER SUHNER	RG-214	01126M	2021/04/22	2022/04/21
Cable-4m (30MHz-1GHz) (V)	HUBER SUHNER	RG-214	02953M	2021/04/22	2022/04/21
Cable-1m (30MHz-1GHz) (V)	HUBER SUHNER	RG-214	01099M	2021/04/22	2022/04/21
Software	AUDIX	E3	Version: V8.2014-8-6	N/A	N/A



EMI TEST REPORT

Equipment : Switching Power Supply

Model No. : FSG032

Trade Name : AcBel

Applicant : AcBel Polytech Inc.

Address : No. 159, Sec. 3, Danjin Rd., Tamsui Dist.,
New Taipei City 251, Taiwan

Standard : Canada ICES-003

HEREBY CERTIFY THAT :

The sample was received on : Dec. 02, 2021

The testing was carried out on : Dec. 20, 2021

The test result refers exclusively to the test presented test model / sample.

Without written approval of CerpPASS Technology Corp., the test report shall not be reproduced except in full.

Approved by:

Kero Kuo / EMC/RF Manager





Contents

Summary of Test Results	4
1. Applicable Standards	4
2. General Description	4
2.1. Product Details	4
2.2. Accessories	4
3. Test Configuration of Equipment under Test	5
3.1. Test Software	5
3.2. Test Manner	5
3.3. Description of Support Unit	5
3.4. General Information of Test.....	5
4. Test of Conducted Emission	6
4.1. Test Limit	6
4.2. Test Procedures	6
4.3. Typical Test Setup	7
4.4. Test Result and Data of Power Port	8
4.5. Test Photographs of Power Port	10
5. Test of Radiated Emission	11
5.1. Test Limit	11
5.2. Test Procedures	12
5.3. Typical Test Setup	12
5.4. Test Result and Data (30MHz ~ 1GHz).....	14
5.5. Test Photographs (30MHz ~ 1GHz)	16
6. Measurement Uncertainty	17
7. List of Measuring Equipment	17



History of this test report

Report No.	Issue Date	Description	Version
21120012-TEIC01	Dec. 23, 2021	Original	A



Summary of Test Results

1. Applicable Standards

The measurements shown in this test report were made in accordance with the procedures given in Canada ICES-003 issue 7 section 3.

The energy emitted by this equipment was passed both Radiated and Conducted Emissions Class **A** limits.

Test Item	Normative References	Test Result
Conducted Emission	Canada ICES-003 issue 7	PASS
Radiation Emission	Canada ICES-003 issue 7	PASS

Note*: Pass criterion is defined by the applicant. The test report is to follow the applicant specification.

The lab has reduced the uncertainty risk factor from test equipment, environment and staff technicians which according to the standard on contract. Therefore, the test result will only be determined by standard requirement.

2. General Description

2.1. Product Details

Input: (1) 100-127V~, 50/60Hz, 10A MAX
200-240V~, 50/60Hz, 5A MAX
240VDC, 5A MAX
(2) 200-240V~, 50/60Hz, 5A MAX
240VDC, 5A MAX
Output: +12V/65A, +12Vsb/2A
Total Power 800W MAX.

2.2. Accessories

N/A



3. Test Configuration of Equipment under Test

3.1. Test Software

N/A

3.2. Test Manner

- a. During testing, the interface cables and equipment positions were varied according to ANSI C63.4-2014.
- b. The test modes of EMI test as follow:

Conducted Emission for AC main power and Radiation Emissions	
Test Mode 1	AC 120V, Full Load in Case
Test Mode 2	DC 240V, Full Load in Case
Test Mode 3	AC 240V, Full Load in Case
caused "Test Mode 1" generated the worst case, these were reported as the final data.	

- c. The maximum operating frequency is 70kHz below 108MHz, the test frequency range is from 30MHz to 1GHz.

3.3. Description of Support Unit

No	Device	Manufacturer	Model No.	Description
1	Case	N/A	N/A	N/A
2	Load	N/A	N/A	N/A

3.4. General Information of Test

Test Site	CerpPASS Technology Corporation Test Laboratory Address: No.10, Ln. 2, Lianfu St., Luzhu Dist., Taoyuan City 33848, Taiwan (R.O.C.) Tel:+886-3-3226-888 Fax:+886-3-3226-881
	<input checked="" type="checkbox"/> Conducted emission test (CON01-NK) <input type="checkbox"/> Conducted emission test (CON02-NK) <input checked="" type="checkbox"/> Radiated emission test (10M01-NK) <input type="checkbox"/> Radiated emission test (3M01-NK) <input type="checkbox"/> Radiated emission test (3M02-NK) <input type="checkbox"/> Radiated disturbance above 1GHz (10M01-NK) <input type="checkbox"/> Radiated disturbance above 1GHz (3M01-NK) <input type="checkbox"/> Radiated disturbance above 1GHz (3M02-NK)
Frequency Range Investigated:	Conducted: from 150 kHz to 30 MHz Radiation: from 30 MHz to 1,000 MHz
Test Distance :	The test distance of radiated emission below 1GHz from antenna to EUT is 10 M. The test distance of radiated emission above 1GHz from antenna to EUT is 3 M.



4. Test of Conducted Emission

4.1. Test Limit

Conducted Emissions were measured from 150 kHz to 30 MHz with a bandwidth of 9 KHz, according to the methods defined in ANSI C63.4-2014. The EUT was placed on a nonmetallic stand in a shielded room 0.8 meters above the ground plane. The interface cables and equipment positioning were varied within limits of reasonable applications to determine the position produced maximum conducted emissions.

Table 1 Conducted Emission Limits (dB μ V):

Frequency range (MHz)	Class A Equipment		Class B Equipment	
	Quasi Peak	Average	Quasi Peak	Average
0.15 to 0.50	79	66	66 to 56*	56 to 46*
0.50 to 5	73	60	56	46
5. to 30.	73	60	60	50

*The limit decreases linearly with the logarithm of the frequency in the range 0.15 MHz to 0.5MHz.

4.2. Test Procedures

- The EUT was placed 0.4 meter from the conducting wall of the shielding room was kept at least 80 centimeters from any other grounded conducting surface.
- Connect EUT to the power mains through a line impedance stabilization network (LISN).
- All the support units are connecting to the other LISN.
- The LISN provides 50 ohm coupling impedance for the measuring instrument.
- The FCC states that a 50 ohm, 50 micro-Henry LISN should be used.
- Both sides of AC line were checked for maximum conducted interference.
- The frequency range from 150 kHz to 30 MHz was searched.
- Set the test-receiver system to Peak Detect Function and Specified Bandwidth with Maximum Hold Mode.



4.3. Typical Test Setup

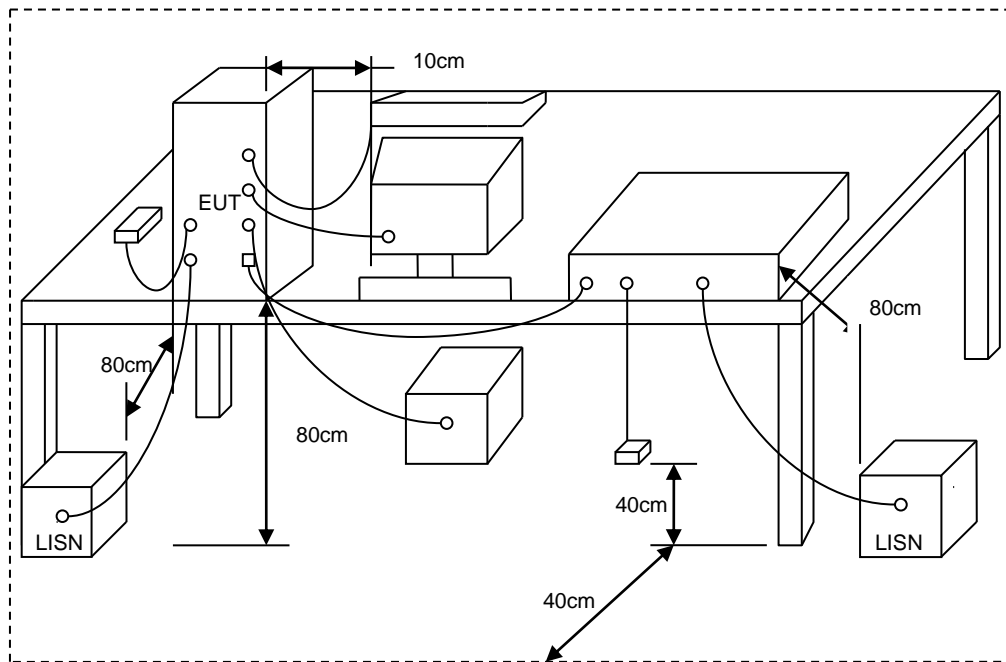



4.4. Test Result and Data of Power Port

Test Mode	Mode 1	Pol/Phase	LINE
Test Frequency	0.15 MHz ~ 30 MHz	Test Voltage	AC 120V
Test Date	Dec. 20, 2021	Test Engineer	Jack
Temperature	20°C	Relative Humidity	50%

Note : Level = Reading + Factor
 Margin = Level – Limit
 Factor= (LISN or PLC or Current Probe) Factor + Cable Loss + Attenuator

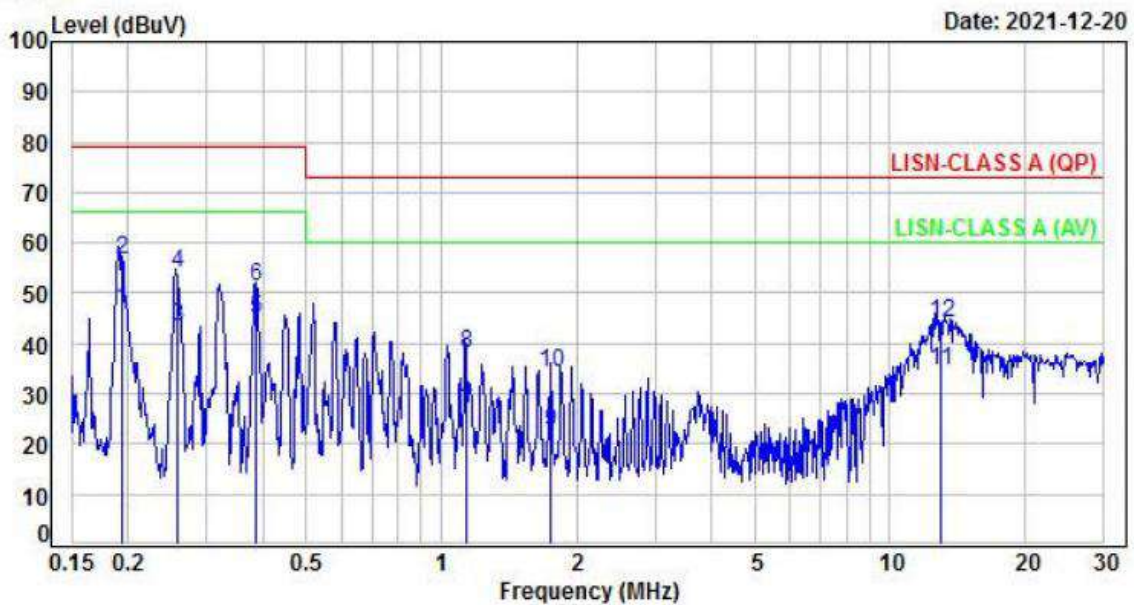

No.	Frequency (MHz)	Factor (dB)	Reading (dBuV)	Level (dBuV)	Limit (dBuV)	Margin (dB)	Detector	P/F
1	0.19	9.97	36.65	46.62	66.00	-19.38	Average	P
2	0.19	9.97	46.76	56.73	79.00	-22.27	QP	P
3	0.26	9.97	33.37	43.34	66.00	-22.66	Average	P
4	0.26	9.97	44.02	53.99	79.00	-25.01	QP	P
5	0.39	9.98	35.05	45.03	66.00	-20.97	Average	P
6	0.39	9.98	41.22	51.20	79.00	-27.80	QP	P
7	1.13	10.06	16.30	26.36	60.00	-33.64	Average	P
8	1.13	10.06	28.03	38.09	73.00	-34.91	QP	P
9	1.75	10.11	12.27	22.38	60.00	-37.62	Average	P
10	1.75	10.11	24.26	34.37	73.00	-38.63	QP	P
11	12.95	10.51	24.10	34.61	60.00	-25.39	Average	P
12	12.95	10.51	33.70	44.21	73.00	-28.79	QP	P



Test Mode	Mode 1	Pol/Phase	NEUTRAL
Test Frequency	0.15 MHz ~ 30 MHz	Test Voltage	AC 120V
Test Date	Dec. 20, 2021	Test Engineer	Jack
Temperature	20°C	Relative Humidity	50%

Note : Level = Reading + Factor
 Margin = Level – Limit
 Factor= (LISN or PLC or Current Probe) Factor + Cable Loss + Attenuator

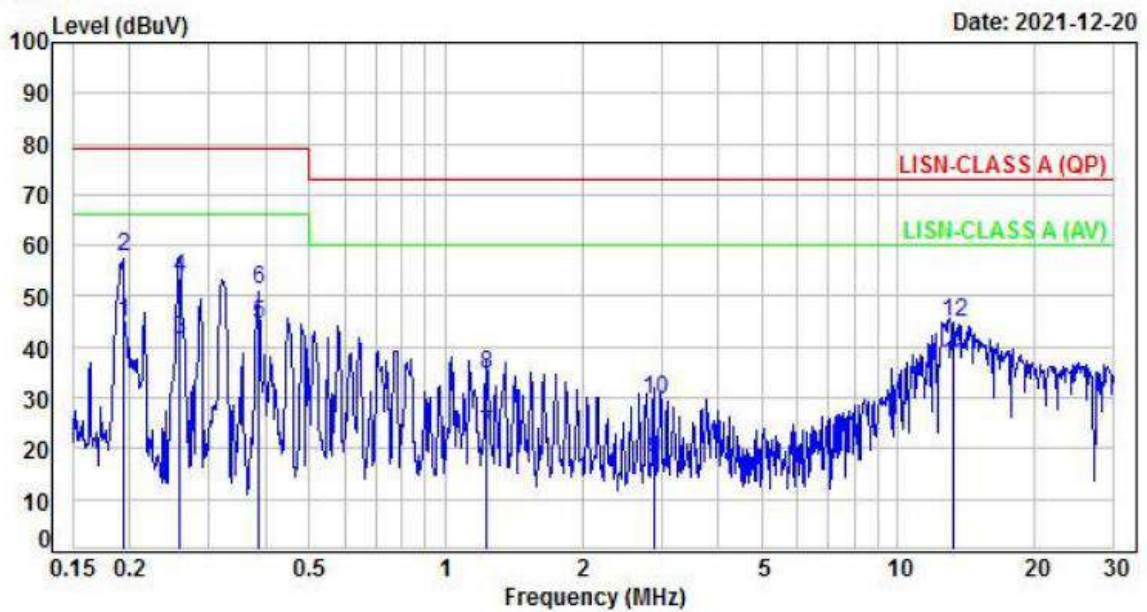

No.	Frequency (MHz)	Factor (dB)	Reading (dBUV)	Level (dBUV)	Limit (dBUV)	Margin (dB)	Detector	P/F
1	0.19	9.97	34.83	44.80	66.00	-21.20	Average	P
2	0.19	9.97	47.85	57.82	79.00	-21.18	QP	P
3	0.26	9.97	31.55	41.52	66.00	-24.48	Average	P
4	0.26	9.97	43.76	53.73	79.00	-25.27	QP	P
5	0.39	9.98	34.51	44.49	66.00	-21.51	Average	P
6	0.39	9.98	41.44	51.42	79.00	-27.58	QP	P
7	1.23	10.06	12.67	22.73	60.00	-37.27	Average	P
8	1.23	10.06	24.58	34.64	73.00	-38.36	QP	P
9	2.88	10.14	7.64	17.78	60.00	-42.22	Average	P
10	2.88	10.14	19.43	29.57	73.00	-43.43	QP	P
11	13.21	10.50	25.90	36.40	60.00	-23.60	Average	P
12	13.21	10.50	34.29	44.79	73.00	-28.21	QP	P



4.5. Test Photographs of Power Port

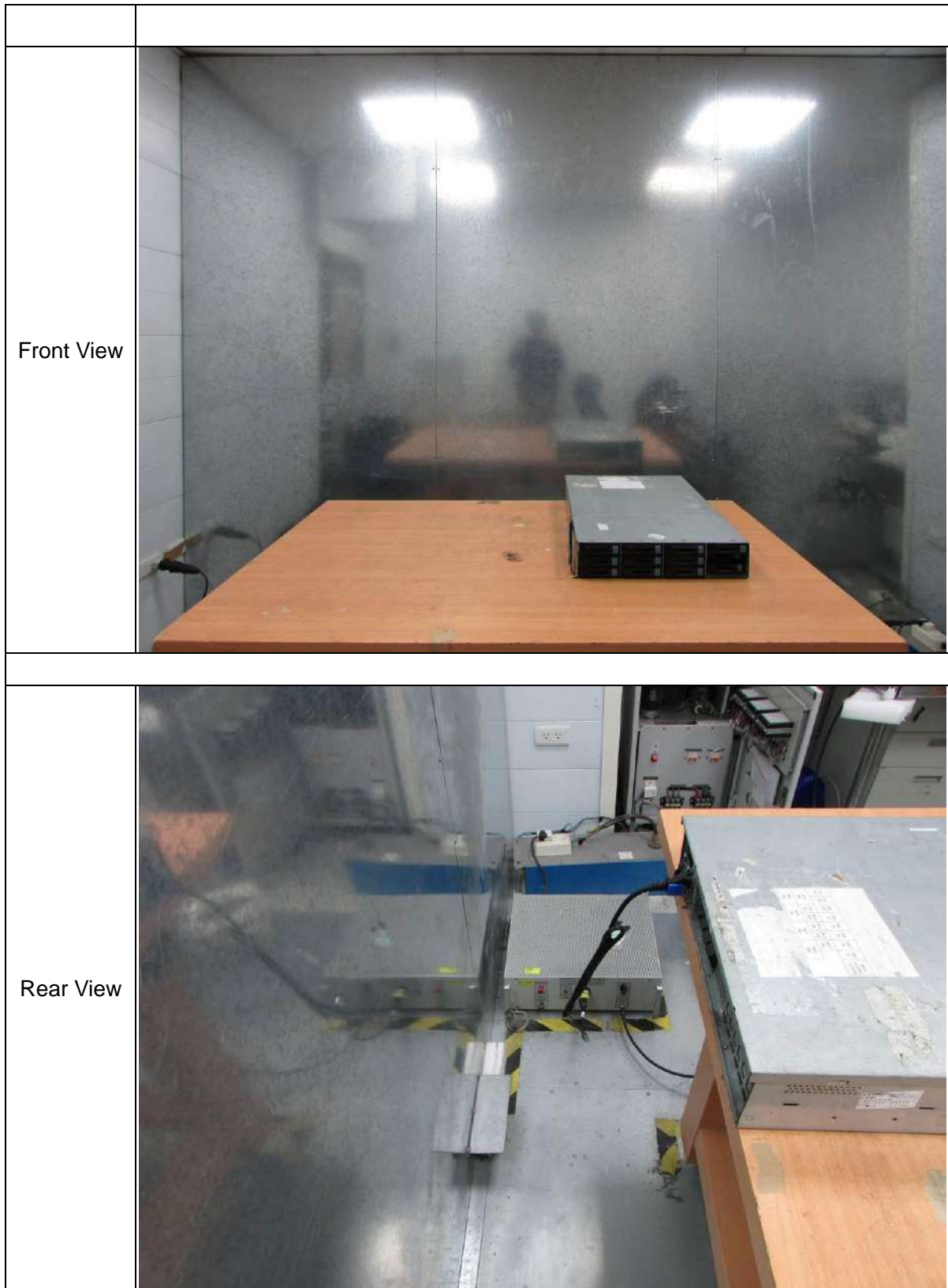



5. Test of Radiated Emission

5.1. Test Limit

Radiated emissions from 30 MHz to 1,000 MHz were measured with a bandwidth of 120 kHz according to the methods defines in ANSI C63.4-2014. The EUT was placed on a nonmetallic stand in the open-field site, 0.8 meter above the ground plane. The interface cables and equipment positions were varied within limits of reasonable applications to determine the positions producing maximum radiated emissions.

For unintentional device, according to § 15.109(a), except for Class A digital devices, the field strength of radiated emissions from unintentional radiators at a distance of 3 meters shall not exceed the following values:

Table 1 – Frequency below 1GHz

Frequency range (MHz)	Class A Equipment (dB μ V/m, quasi-peak)		Class B Equipment (dB μ V/m, quasi-peak)	
	3m	10m	3m	10m
30-88	50	40	40	30
88-216	54	43.5	43.5	33.1
216-230	56.9	46.4	46	35.6
230-960	57.0	47.0	47.0	37.0
960-100	60.0	49.5	54.0	43.5

Note: The more stringent limit applies at transition frequencies.

Table 2 –Frequency above 1GHz

Frequency range (GHz)	Class A b, c, d		Class B b, c, d	
	Average dB(μ V/m)	Peak dB(μ V/m)	Average dB(μ V/m)	Peak dB(μ V/m)
1-FM	60	80	54	74

a. The highest measurement frequency, FM, in GHz, shall be determined as per Table 3.
b. The measurement bandwidth shall be 1 MHz or greater.
c. These limit levels apply for a measurement distance of 3 m. If using a different measurement distance, the measured levels shall be extrapolated to the 3 m limit distance using a factor of 20 dB per decade of distance. The measurement distance shall place the measurement antenna in the far field of the ITE or digital apparatus under test.
d. The test site shall be a free-space OATS (FSOATS), as defined in CAN/CSA-CISPR 32:17, and it shall be validated at the distance used for radiated emission measurements on the ITE or digital apparatus under test.

Table 3: Required highest measurement frequency for radiated emissions

Highest internal frequency (FX) a	Highest measurement frequency (FM)
FX \leq 108 MHz	1 GHz
108 MHz < FX \leq 500 MHz	2 GHz
500 MHz < FX \leq 1 GHz	5 GHz
FX > 1 GHz	5 x FX up to a maximum of 40 GHz

a. FX is defined in 3.1.18 of CAN/CSA-CISPR 32:17.



5.2. Test Procedures

- a. The EUT was placed on a rotatable table top 0.8 meter above ground.
- b. The EUT was set 10 meters from the interference receiving antenna which was mounted on the top of a variable height antenna tower.
- c. The table was rotated 360 degrees to determine the position of the highest radiation.
- d. The antenna is a half wave dipole and its height is varied between one meter and four meters above ground to find the maximum value of the field strength both horizontal polarization and vertical polarization of the antenna are set to make the measurement.
- e. For each suspected emission the EUT was arranged to its worst case and then tune the antenna tower (from 1 M to 4 M) and turn table (from 0 degree to 360 degrees) to find the maximum reading.
- f. Set the test-receiver system to Peak Detect Function and specified bandwidth with Maximum Hold Mode.
- g. If the emission level of the EUT in peak mode was 6 dB lower than the limit specified, then testing will be stopped and peak values of EUT will be reported, otherwise, the emissions which do not have 6 dB margin will be repeated one by one using the quasi-peak method and reported.

5.3. Typical Test Setup

Below 1GHz Test Setup

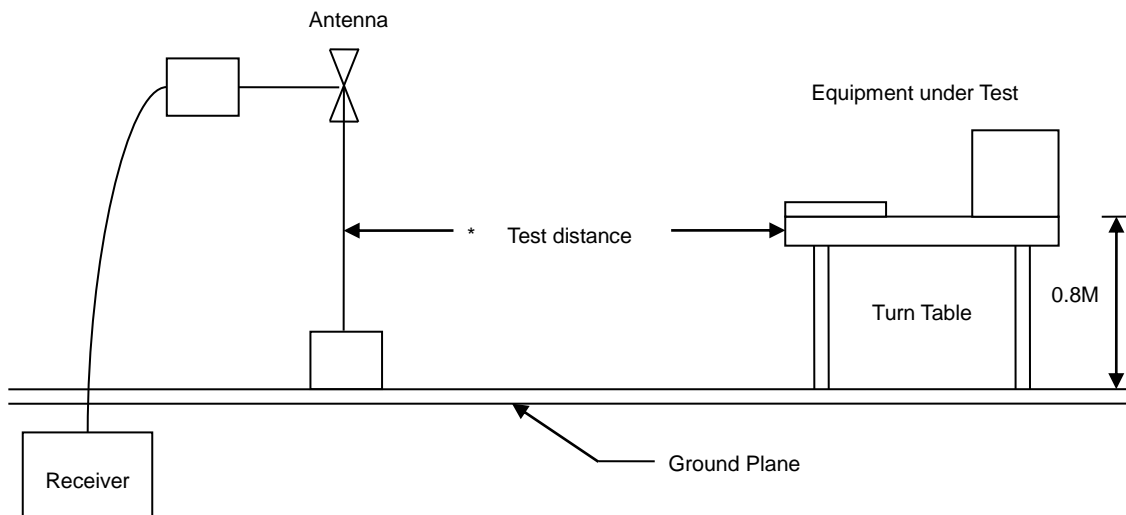



Above 1GHz Test Setup

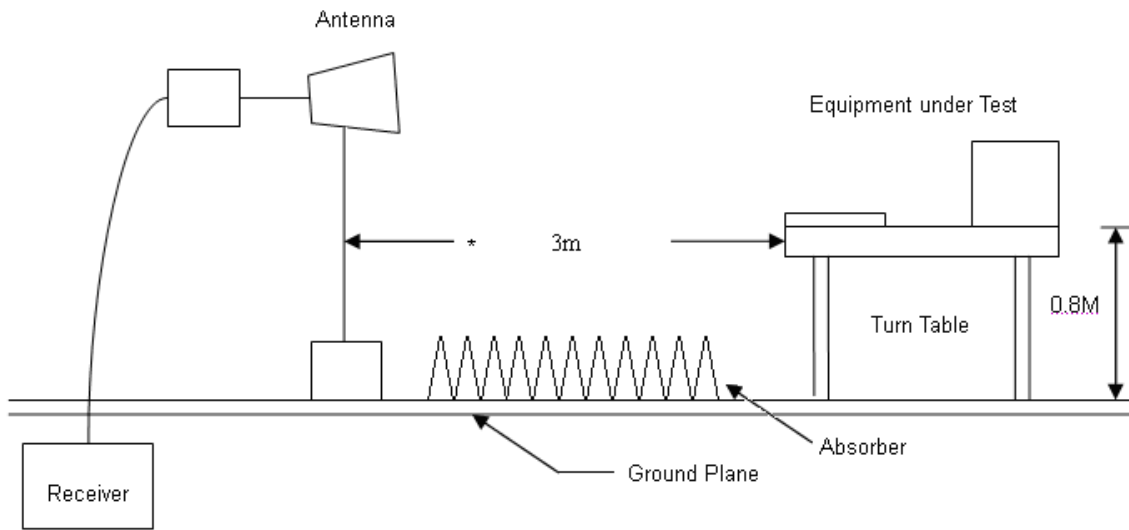



5.4. Test Result and Data (30MHz ~ 1GHz)

Test Mode	Mode 1	Pol/Phase	VERTICAL
Test Frequency	30 MHz ~ 1 GHz	Test Voltage	AC 120V
Test Date	Dec. 20, 2021	Test Engineer	Tim
Temperature	20°C	Relative Humidity	57%

Note : Level = Reading + Factor
 Margin = Level - Limit
 Factor = Antenna Factor + Cable Loss - Amplifier Factor

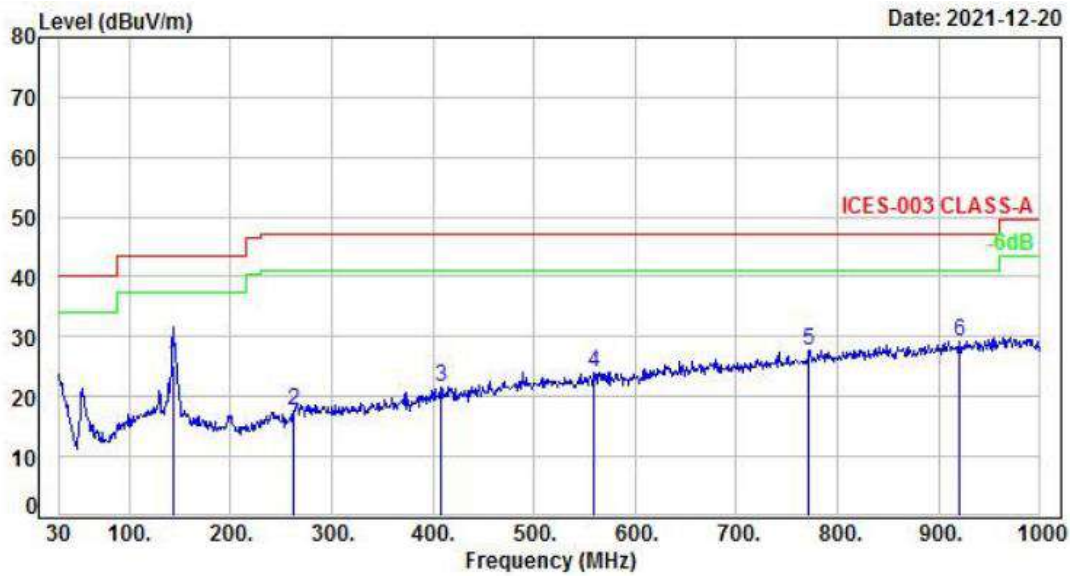

No.	Frequency (MHz)	Factor (dB/m)	Reading (dBuV)	Level (dBuV/m)	Limit (dBuV/m)	Margin (dB)	Detector	Height (cm)	Azimuth (deg)	P/F
1	143.49	-10.55	35.70	25.15	43.50	-18.35	QP	200	111	P
2	262.80	-10.22	27.92	17.70	47.00	-29.30	Peak	100	246	P
3	407.33	-6.38	27.92	21.54	47.00	-25.46	Peak	200	160	P
4	559.62	-3.09	27.16	24.07	47.00	-22.93	Peak	400	68	P
5	772.05	0.27	27.28	27.55	47.00	-19.45	Peak	400	178	P
6	920.46	2.31	26.78	29.09	47.00	-17.91	Peak	100	239	P



Test Mode	Mode 1	Pol/Phase	HORIZONTAL
Test Frequency	30 MHz ~ 1 GHz	Test Voltage	AC 120V
Test Date	Dec. 20, 2021	Test Engineer	Tim
Temperature	20°C	Relative Humidity	57%

Note : Level = Reading + Factor
 Margin = Level - Limit
 Factor = Antenna Factor + Cable Loss - Amplifier Factor

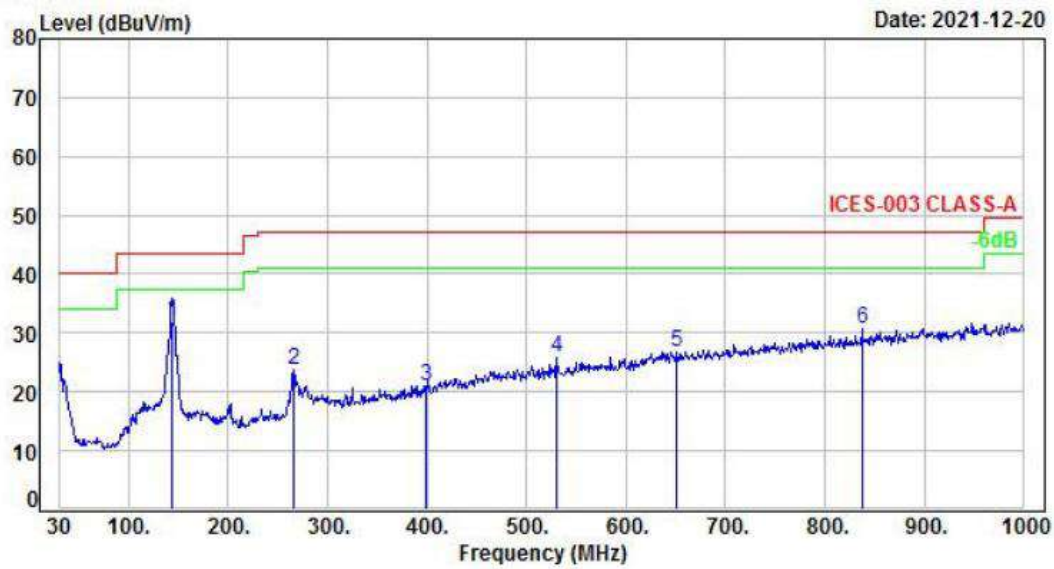

No.	Frequency (MHz)	Factor (dB/m)	Reading (dBUV)	Level (dBUV/m)	Limit (dBUV/m)	Margin (dB)	Detector	Height (cm)	Azimuth (deg)	P/F
1	143.49	-9.65	41.71	32.06	43.50	-11.44	QP	400	187	P
2	265.71	-8.71	32.48	23.77	47.00	-23.23	Peak	400	162	P
3	398.60	-5.15	26.29	21.14	47.00	-25.86	Peak	100	219	P
4	530.52	-1.83	27.84	26.01	47.00	-20.99	Peak	100	87	P
5	650.80	0.86	26.03	26.89	47.00	-20.11	Peak	100	322	P
6	837.04	4.18	26.46	30.64	47.00	-16.36	Peak	400	261	P



5.5. Test Photographs (30MHz ~ 1GHz)

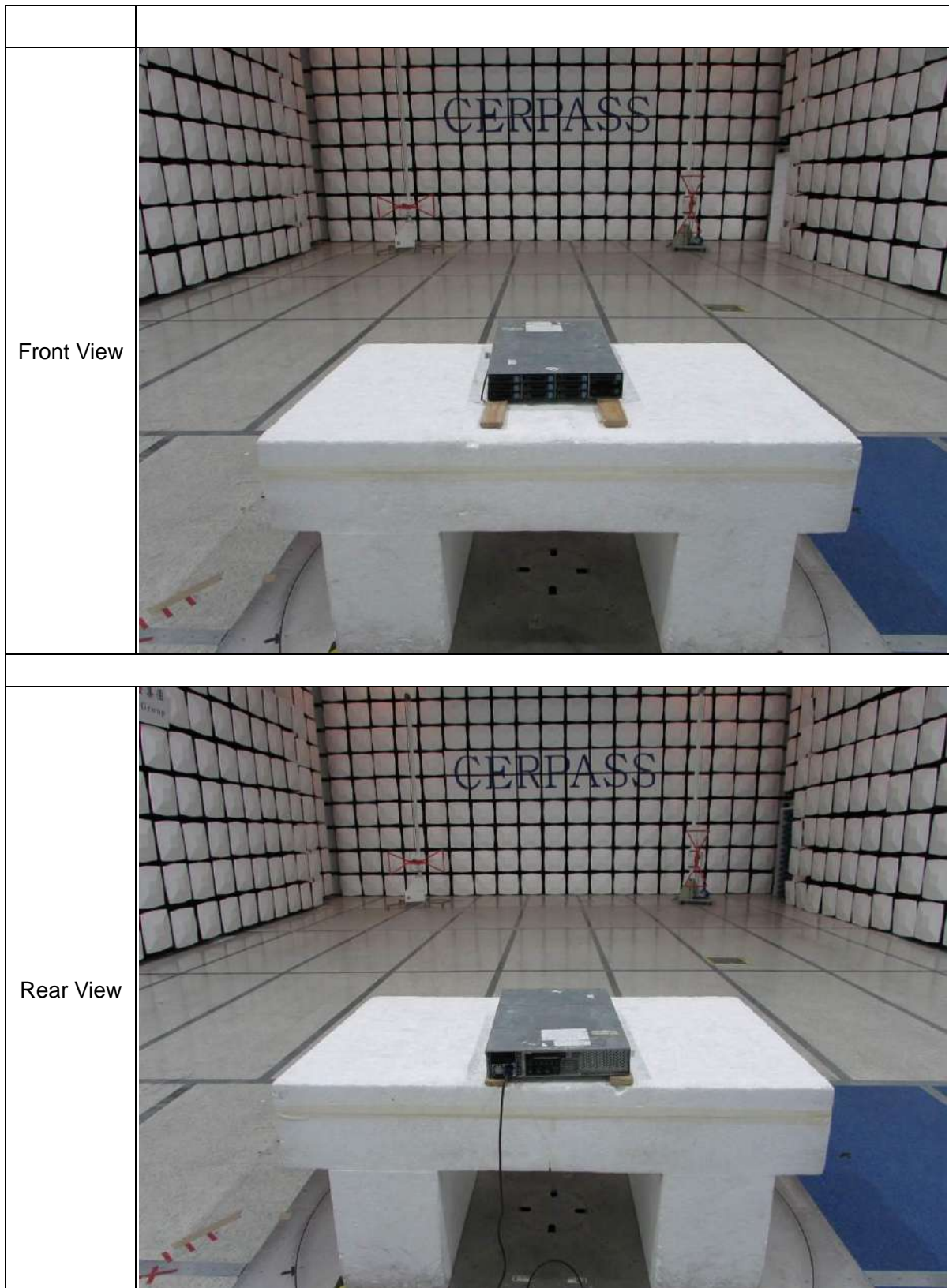



6. Measurement Uncertainty

Measurement Item	Measurement Frequency	Polarization	Uncertainty
Conducted Emission	150 kHz ~ 30 MHz	Line / Neutral	±3.12dB
Radiated Emission	30 MHz ~ 1,000 MHz	Vertical / Horizontal	±4.53dB
	1,000 MHz ~ 6,000 MHz	Vertical / Horizontal	±4.93dB
	6,000 MHz ~ 18,000 MHz	Vertical / Horizontal	±5.11dB

The measurement uncertainty will be considered, when test result margin to the limit.

ISO/IEC 17025 requires that an estimate of the measurement uncertainties associated with the emissions test results be included in the report. The measurement uncertainties given below are based on a 95% confidence level (based on a coverage factor (k=2)).

7. List of Measuring Equipment

Conducted Emission (Test date: 2021/12/20)					
Instrument	Manufacturer	Model No.	Serial No.	Calibration Date	Valid Date
EMI Receiver	R&S	ESCI	101200	2021/08/30	2022/08/29
LISN	Schwarzbeck	NSLK 8127	8127-568	2021/06/02	2022/06/01
Pulse Limiter	R&S	ESH3-Z2	101934	2021/03/10	2022/03/09
Cable-6m (9kHz~300MHz)	N/A	CFD300-NL	N/A	2021/03/15	2022/03/14
Software	AUDIX	E3	Version: V8.2014-8-6	N/A	N/A

Radiated Emission below 1GHz (Test date: 2021/12/20)					
Instrument	Manufacturer	Model No.	Serial No.	Calibration Date	Valid Date
Bilog Antenna(V)	Sunol	JB1	A020514-1	2021/03/18	2022/03/18
Bilog Antenna(H)	Sunol	JB1	A020514-2	2021/05/06	2022/05/05
EMI Receiver(V)	R&S	ESCI	100443	2021/05/20	2022/05/19
EMI Receiver(H)	R&S	ESCI	101402	2021/03/12	2022/03/11
Preamplifier(V)	EM Electronics corp.	EM330	60644	2021/09/17	2022/09/16
Preamplifier(H)	EM Electronics corp.	EM330	60610	2021/03/09	2022/03/08
Cable-16m (30MHz-1GHz) (H)	HUBER SUHNER	RG-214	01110M	2021/03/26	2022/03/25
Cable-4m (30MHz-1GHz) (H)	HUBER SUHNER	RG-214	02951M	2021/03/26	2022/03/25
Cable-1m (30MHz-1GHz) (H)	HUBER SUHNER	RG-214	01098M	2021/03/26	2022/03/25
Cable-10m (30MHz-1GHz) (V)	HUBER SUHNER	RG-214	01126M	2021/04/22	2022/04/21
Cable-4m (30MHz-1GHz) (V)	HUBER SUHNER	RG-214	02953M	2021/04/22	2022/04/21
Cable-1m (30MHz-1GHz) (V)	HUBER SUHNER	RG-214	01099M	2021/04/22	2022/04/21
Software	AUDIX	E3	Version: V8.2014-8-6	N/A	N/A