



HA201-PV

**Storage Barebone
User's Manual**

Table of Contents

Preface	i
Safety Instructions	ii
About This Manual	iv
1.1 Box Content.....	1
Chapter 1. Product Features	1
1.2 Specifications	2
1.3 Features	3
2.1 Central Processing Unit Setup	6
2.1.1 Processor Installation.....	6
Chapter 2. Hardware Setup	6
2.2 System Memory	9
2.2.1 Dual Processor	9
2.2.2 Recommended Dimm Installation Order	10
2.2.3 DIMM Installation.....	12
2.3 Top Cover	13
2.4 Power Supply Unit Module.....	14
2.5 Node	15
2.6 Fan Module	16
2.7 Hard Disk Drive.....	17
2.8 HDD Backplane Module	18
2.9 Slide Rail Installation	19
Chapter 3. Motherboard Settings	22
3.1 Block Diagram	22
3.2 Content List.....	23
3.3 Placement	24
3.4 Connector and Jumper	25
3.5 System LED Indicator	29
3.5.1 Front Panel	29
3.5.2 Rear I350 LAN	29
3.5.3 Rear PCH LAN	30
3.5.4 Rear UID and Internal LED.....	31
3.6 HDD Backplane.....	32
3.6.1 Placement.....	32
3.6.2 Connector and Jumper	33
3.7 Expander	34
3.7.1 Placement.....	34
3.7.2 Connector and Jumper	35
3.7.3 LED Indicator	37
3.8 Riser Card	38
3.8.1 Placement.....	38
3.8.2 Connector and Jumper	38
3.8.3 LED Indicator	39
Chapter 4. BIOS Configuration Settings	40
4.1 Navigation Keys.....	40
4.2 BIOS Setup	41

4.2.1 Menu	41
4.2.2 Startup	41
4.3 Main	44
4.3.1 Main	44
4.4 Advanced	45
4.4.1 Peripheral Configuration	45
4.4.2 Video Configuration	45
4.4.3 Socket Configuration	45
4.4.4 PCH Configuration	49
4.4.5 H2o IPMI Configuration	53
4.4.6 H2o Event Log Config Manager	54
4.5 Security	55
4.5.1 Security	55
4.6 Power	56
4.6.1 Power	56
4.7 Boot	57
4.7.1 Boot	57
4.8 Exit	58
4.8.1 Exit	58
4.9 BIOS Update Process	59
Chapter 5. BMC Configuration Settings	60
5.1 BIOS Setup	60
5.2 Login	63
5.3 Web GUI	64
5.3.1 Menu Bar	64
5.3.2 User Information and Quick Button	65
5.3.3 Dashboard:	66
5.3.4 Sensor	66
5.3.5 FRU Information	66
5.3.6 Logs and Report	67
5.3.7 Settings	67
5.3.8 KVM Mouse Setting	68
5.3.9 Firmware Update	70
5.3.10 BIOS Firmware Update	74
Chapter 6. Technical Support	76



Copyright © 2020 AIC, Inc. All Rights Reserved.

This document contains proprietary information about AIC products and is not to be disclosed or used except in accordance with applicable agreements.

Document Release History

Release Date	Version	Update Content
March 2020	1	User's Manual release to public.
January 2021	1.1	ME QiG update
September 2022	1.2	Section 4.9/ Section 5.3 Firmware update.

Preface

Copyright

No part of this publication may be reproduced, stored in a retrieval system, or transmitted in any form or by any means, electronic, mechanical, photo-static, recording or otherwise, without the prior written consent of the manufacturer.

Trademarks

All products and trade names used in this document are trademarks or registered trademarks of their respective holders.

Changes

The material in this document is for information purposes only and is subject to change without notice.

Warning

1. A shielded-type power cord is required in order to meet FCC emission limits and also to prevent interference to the nearby radio and television reception. It is essential that only the supplied power cord be used.
2. Use only shielded cables to connect I/O devices to this equipment.
3. You are cautioned that changes or modifications not expressly approved by the party responsible for compliance could void your authority to operate the equipment.

Disclaimer

AIC shall not be liable for technical or editorial errors or omissions contained herein. The information provided is provided "as is" without warranty of any kind. To the extent permitted by law, neither AIC or its affiliates, subcontractors or suppliers will be liable for incidental, special or consequential damages including downtime cost; lost profits; damages relating to the procurement of substitute products or services; or damages for loss of data, or software restoration. The information in this document is subject to change without notice.

Instruction Symbols

Special attention should be given to the instruction symbols below.



NOTE

This symbol indicates that there is an explanatory or supplementary instruction.



CAUTION

This symbol denotes possible hardware impairment. Upmost precaution must be taken to prevent serious hardware damage.



WARNING

This symbol serves as a warning alert for potential body injury. The user may suffer possible injury from disregard or lack of attention.

Safety Instructions

Before you commence, please attentively read the following important discretions below. All cautions and warnings on the equipment or in the manuals should be circumspactly noted and reviewed.

Always ground yourself to prevent static electricity.

請全程接地，以防止靜電。

请全程接地，以防止静电。

Всегда заземляйте себя, чтобы избежать статического электричества.

Aard jezelf altijd om statische elektriciteit te voorkomen.

- Firmly ground yourself at all times when installing or assembling the internal components of the server. Most of electronic components in the server are highly sensitive to electrical static discharge.
- Use a solid grounding wrist strap and distintively place all electronic components in static-shielded devices to prevent static. Grounding wrist straps can be purchased in any electronic supply store.
- Confirm that the power source is turned off and then disconnect the power cords from your system before performing any type of installation or manual servicing. A sudden surge of power could serverly damage the sensitive electronic components.
- Do not precipitously open the system's top cover. If you must open the cover for maintenance purposes, only a trained technician should be allowed to proceed this action. Integrated circuits on computer boards are highly sensitive to static electricity. Before operating a board or integrated circuit, touch an unpainted portion of the system unit chassis for a couple of seconds to discharge any static electricity on your body.

Place the server in a stable environment.

請將伺服器放置在穩定的環境中。

请将伺服器放置在稳定的环境中。

Поместите сервер в стабильную среду.

Plaats de server in een stabiele omgeving.

- Place this equipment on a stable surface when installing. A small mild drop or fall could cause fatal injury to both the equipment and the person handling the equipment.
- Please keep this equipment away from humidity to prevent vast rust and disintergration.
- Carefully and accurately mount the equipment into the rack. Uneven mechanical loading may lead to hazadous consequences.
- This equipment is to be installed for operation in an environment with maximum ambient temperature below 35°C.
- Review the environment before performing any installation or servicing. Keep the equipment away from hazardous and uneven grounds.
- This server must be installed only in Restricted Access Locations.

Handle equipment with care.

請謹慎操作設備。

请谨慎操作设备。

Обращайтесь с оборудованием осторожно.

Behandel de apparatuur voorzichtig.

- Do not cover the openings of the system. The openings on the system are for air convection, which intentionally protect the equipment from overheating.
- Never pour any liquid into ventilation openings of the system. This could cause catastrophic fire or electrical shock.

- Ensure that the voltage of the power source is within the specification on the label when connecting the equipment to the power outlet. The current load and output power of loads must be within the specification.
- This equipment must be firmly connected to reliable grounding before usage. Pay special attention to power supplied other than direct connections, e.g. using of power strips.
- Place the power cord out of the way of foot traffic. Do not place anything over the power cord. The power cord must be rated for the product, voltage and current marked on the product's electrical ratings label. The voltage and current rating of the cord should be greater than the voltage and current rating marked on the product.

Pay attention to hardware maintenance.

注意硬體維護。

注意硬体维护。

Обратите внимание на обслуживание оборудования.

Besteed aandacht aan hardware-onderhoud.

- If the equipment is not used for a long time, disconnect the equipment from mains to avoid being damaged by transient over-voltage.
- Module and drive bays must not be empty. They must have a dummy cover.
- Never open the equipment without professional assistance. For safety reasons, only qualified service personnel should open the equipment.
- If one of the following situations arise, the equipment should be checked and tested by service personnel:
 1. The power cord or plug is damaged.
 2. Liquid has penetrated the equipment.
 3. The equipment has been exposed to moisture.
 4. The equipment does not work well or will not work according to its user manual.
 5. The equipment has been dropped and/or damaged.
 6. The equipment has obvious signs of breakage.
 7. Please disconnect this equipment from the AC outlet before cleaning. Do not use liquid or detergent for cleaning. The use of a moisture sheet or cloth is recommended for cleaning.



CAUTION

The equipment intended for installation should be placed in Restricted Access Location.



CAUTION

There will be a risk of explosion if battery is replaced by an incorrect type. Dispose of used batteries according to the instructions. After performing any installation or servicing, make sure the enclosure is correct in position before turning on the power.



CAUTION

This unit may have more than one power source. Disconnect all power sources before maintenance to avoid electric shock.



Disconnect all power sources before

About This Manual

Thank you for selecting and purchasing the HA201-PV.

This user's manual is provided for professional technicians to perform easy hardware setup, basic system configurations, and quick software startup. This document pellucidly presents a brief overview of the product design, device installation, and firmware settings for HA201-PV.

Chapter 1 Product Features

HA201-PV is a flexible storage server barebone that is specifically designed to accommodate diverse corporations and enterprises for managing heavy workloads and multiple applications.

Chapter 2 Hardware Setup

This chapter displays an easy installation guide for assembling the hardware in this product. Utmost caution for proceeding to set up the hardware is highly advised. Most of the components are highly fragile and vulnerable to exterior influence. Do not endanger the device by placing the device in an unstable environment.

Chapter 3 Hardware Settings

This chapter elaborates the overall layout of the server motherboard, including multifarious connectors, jumpers, and LED descriptions. These descriptions assist users to configure different settings and functions of the motherboard, as well as to confirm the location of each connector and jumper.

Chapter 4 BIOS Configuration Settings

This chapter introduces the key features of BIOS, including the descriptions and option keys for diverse functions. These details provide users to effortlessly navigate and configure the input/output devices.

Chapter 5 BMC Configuration Settings

This chapter illustrates the diverse functions of IPMI BMC, including the details on logging into the web page and assorted definitions. These descriptions are helpful in configuring various functions through Web GUI without entering the BIOS setup. For more information of BMC configurations, please refer to IPMI BMC (Aspeed AST2500) User's Manual for a more detailed description.

Chapter 6 Technical Support

For more information or suggestion, please contact the nearest AIC corporation representative in your district or visit the AIC website: <https://www.aicipc.com/en/index>. It is our greatest honor to provide the best service for our customers.

Chapter 1. Product Features

HA201-PV is a 2U high density storage server with 24 hot swap bays for dual-port NVMe SSDs (U.2). For more information about our product, please visit our website at <https://www.aicipc.com/en>.

Before removing the subsystem from the shipping carton, visually inspect the physical condition of the shipping carton. Exterior damage to the shipping carton may indicate that the contents of the carton are damaged. If any damage is found, do not remove the components; contact the dealer where the subsystem was purchased for further instructions. Before continuing, first unpack the subsystem and verify that the number of components in the shipping carton is accurate and in good condition.

1.1 Box Content

This product contains the components listed below.

Please confirm the number and the condition of the components before installation.

- System chassis
(drive tray, fan, power supply unit)
- Power cord (vary per region)
- 28" Tool-less slide rail x 1 set (optional)

⊠ PACKAGE CONTENT MAY VARY PER REGION.

1.2 Specifications

Dimensions (W x D x H)	mm : 435 x 816.85 x 87.9		
	inches : 17.1 x 32.1 x 3.4		
Motherboard (per node)	AIC Server Board Pavo		
Processor (per node)	Processor Support	<ul style="list-style-type: none"> • Intel® Xeon® Scalable Processors (Skylake/Cascade Lake/Cascade Lake Refresh) • Supports CPU TDP up to 165W 	
	UPI Speeds	10.4 GT/s, 9.6 GT/s	
	Socket Type	Socket P0 (LGA-3647 Socket)	
Chipset Support (per node)	Intel® Lewisburg C620 series PCH		
System Memory (per node)	<ul style="list-style-type: none"> • 6 x memory channels per CPU, 2 channels with 2DPC + 4 channels with 1DPC • 16 x DIMM slots support: <ul style="list-style-type: none"> - up to 256GB RDIMM SRx4 - up to 512GB RDIMM DRx4 - up to 2048GB RDIMM 3DS 8Rx4 - up to 1024GB LRDIMM QRx4 - up to 2048GB LRDIMM 3DS 8Rx4 • Intel® Optane™ DC Persistent Memory (Apache Pass) support 		
Front Panel	System power on/off		
LEDs	A	<ul style="list-style-type: none"> • Power(Secondary) • Warning 	
	B	<ul style="list-style-type: none"> • Power(Primary) • Warning 	
Drive Bays	External	2.5" hot swap	24
	Internal	2.5"	2 (per node)
Backplane	1 x 24-port 12Gb SAS dual-loop		
Expansion Slots (per node)	PCIe 3.0	<ul style="list-style-type: none"> • 3 x8 slots (2LP, 1internal LP) • 1 x OCP Mezzanine card V2.0 (Notification: About OCP card, Please contact AIC Technical Support for additional information/details.) 	
Rear I/O (per node)	LAN	<ul style="list-style-type: none"> • 2 x 10GbE SFP+ • 2 x GbE RJ45 • 1 x GbE RJ45 dedicated to BMC management 	
	USB	2 x USB 3.0 Type A	
	VGA	1 x external DB-15 VGA port	
	Serial Port	1 x audio jack for COM port	
TPM Connector	TPM	1 x TPM 2.0 onboard	
Power Supply	1300W 1+1 redundant power supply 80+ Platinum <ul style="list-style-type: none"> • AC INPUT : 100-120V,50/60Hz,12A • DC OUTPUT : 900W • AC INPUT : 200-240V,50/60Hz,8A • DC OUTPUT : 1300W 		
System Cooling (per node)	2 x 60x56mm easy swap fans		

Expander Board (per node)	1 x 36-port 12Gb SAS expander board with 3 SFF-8643 connectors	
Riser Card (included) (per node)	RC-PE2U04-TY	3 x8 PCIe slots
System BIOS	BIOS Type	Insyde UEFI BIOS
	BIOS Features	<ul style="list-style-type: none"> • ACPI • PXE • WOL • AC loss recovery • IPMI KCS interface • SMBIOS • Serial console redirection <ul style="list-style-type: none"> • BIOS Boot Specification • BIOS Recovery Mode • SRIOV • iSCSI • TPM • PCIe Hotplug
On-board Devices	SATA	Intel® Lewisburg PCH on-chip solution <ul style="list-style-type: none"> • 4 x SATA 6.0 Gb/s (by 1 x mini-SAS HD) • 2 x SATA 6.0 Gb/s (by 2 x SATA 7 pin) • 5 x SATA 6.0 Gb/s (by Max I/O®) • RAID 0, 1, 5, 10 support by Intel RSTe
	BMC	Aspeed AST2500 Advanced PCIe Graphics & Remote Management Processor <ul style="list-style-type: none"> • Baseboard Management Controller • Intelligent Platform Interface 2.0 (IPMI 2.0) • iKVM, Media Redirection, IPMI over LAN, Serial over LAN • SMASH Support • HTML5 • Redfish
	Network Controllers	<ul style="list-style-type: none"> • Intel® PCH (Lewisburg) Integrated 10GbE LAN Controller w/ dual SFP+ rear connectors • Intel® I350 dual ports RJ45 rear connectors • Realtek RTL8211E GbE Ethernet for BMC dedicated management port
System Management	Graphics	Aspeed AST2500 Advanced PCIe Graphics & Remote Management Processor <ul style="list-style-type: none"> • PCIe VGA/2D Controller • 1920x1200@60Hz 32bpp
	System Management	<ul style="list-style-type: none"> • IPMI 2.0 • KVM over IP • Media redirection • Temperature, System temperature • System ID • Remote Power • SEL message • SNMP support • Intel NM • HTML5 • Redfish
Environmental Specifications	<ul style="list-style-type: none"> • Storage temperature : -10°C(14°F) ~ 60°C(140°F) • Operating temperature : 0°C(32°F) ~ 35°C(95°F) • Storage operating humidity : 5%~95% non-condensing 	
Gross Weight	(w/ PSU & Rail)	kgs : 41
		lbs : 19
Packaging Dimensions	(W x D x H)	mm : 605 x 1060 x 323
		inches : 23.6 x 41.34 x 12.6
Mounting	Standard	28" tool-less slide rail

1.3 Features

HA201-PV is a reliable 2U 2 node storage server barebone with 24 x 2.5-inch hotswap drives bays. This product is designed to accommodate the AIC-patented serverboard, Pavo, which supports two Intel® Xeon® Scalable Processors and 16 DDR4 DIMM to offer greater performance, efficiency, and utility for our customers. Featuring Intel® C620 Series Chipset, which is emphasized for its accelerated speed and expansion, this product enhances these advantages by integrating flexible IO usage and system expansion into to provide greater bandwidth and utilization.

In addition to the noteworthy features of the barebone, HA201-PV provides immediate and efficient management with Onboard Baseboard Management Controller and greater I/O extension. Featuring IPMI 2.0 and Aspeed AST2500 Advanced PCIe Graphics, the server board offers support for iKVM, Media Redirection, Smash Support, IPMI over LAN, and Serial over LAN.

- 2U 2 Node High-availability storage server support 24 Hot-swap 2.5" SAS drive bays
- High availability storage server optimized for mission critical, enterprise-level storage applications
- Fully redundant, fault-tolerant system supporting hot swappable controller nodes and storage drives
- Support 2nd Gen. Intel® Xeon® Scalable processors (Cascade Lake/Cascade Lake refresh/Skylake)
- 1 PCIe x16, 1 PCIe x8, 1 OCP Mezzanine x16 slots per node provide direct links to CPU
- Option for PCIe NTB line between nodes for communication and fail-over
- Build-in Broadcom SAS3x36R SAS expander per node

Front Panel

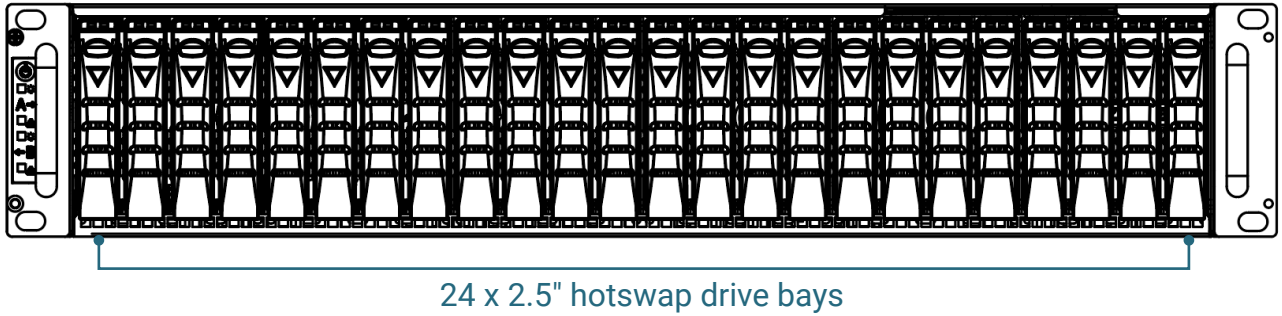

Item	Description
	System Power Button
A → 	Secondary System Power LED
	System Warning LED
← B 	Primary System Power LED
	System Warning LED

Rear Panel

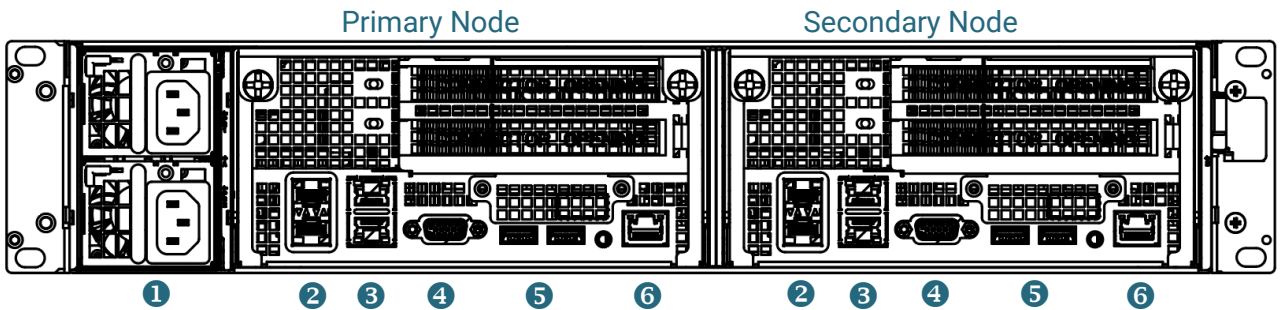

Item	Description
1	1300W 1+1 redundant power supply 80+ Platinum
2	2 x 10GbE SFP+ port
3	2 x GbE RJ45 port
4	1x DB-15 VGA port
5	2 x USB 3.0 port
6	1 x GbE RJ45 dedicated to BMC management port

Major Components

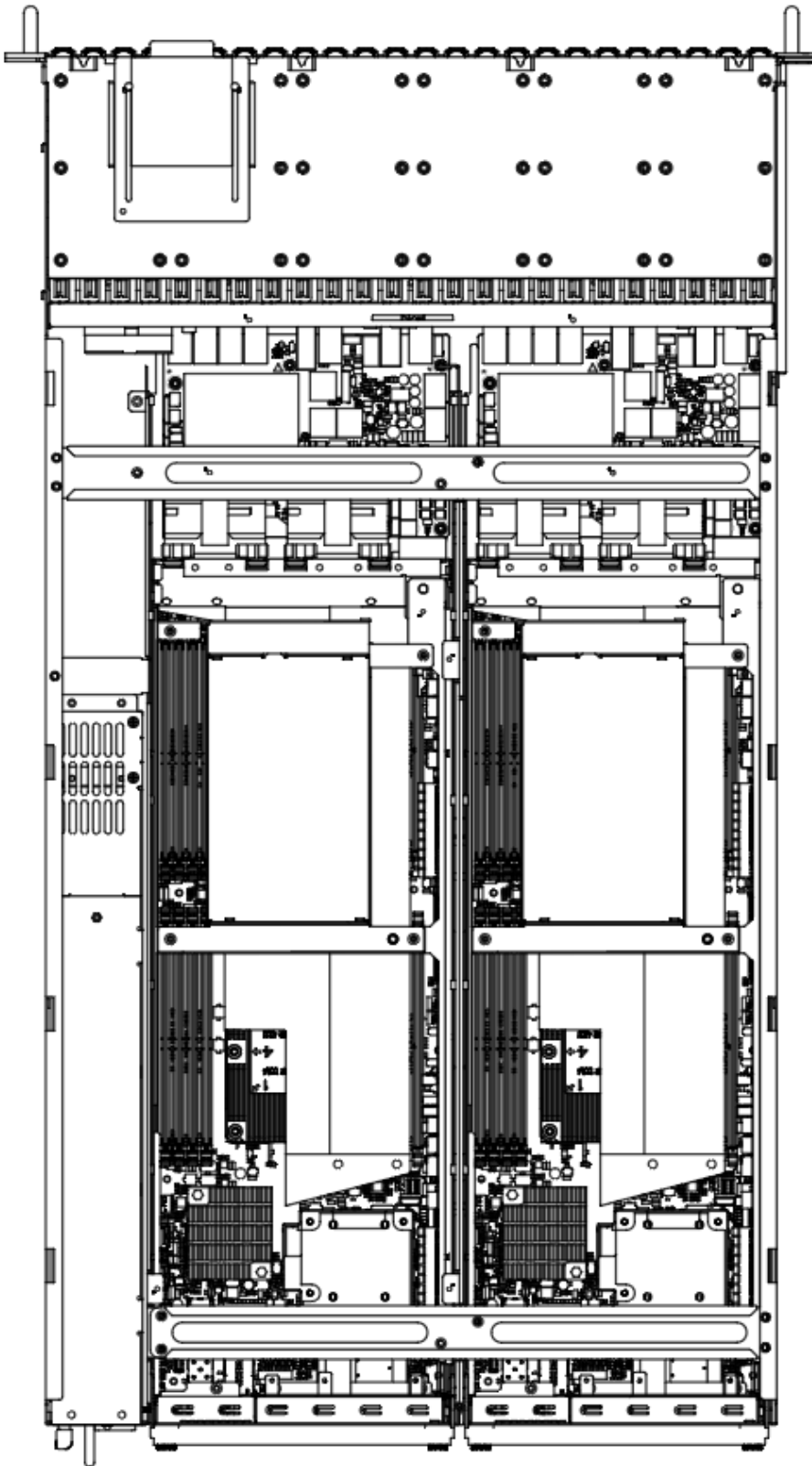

Top view

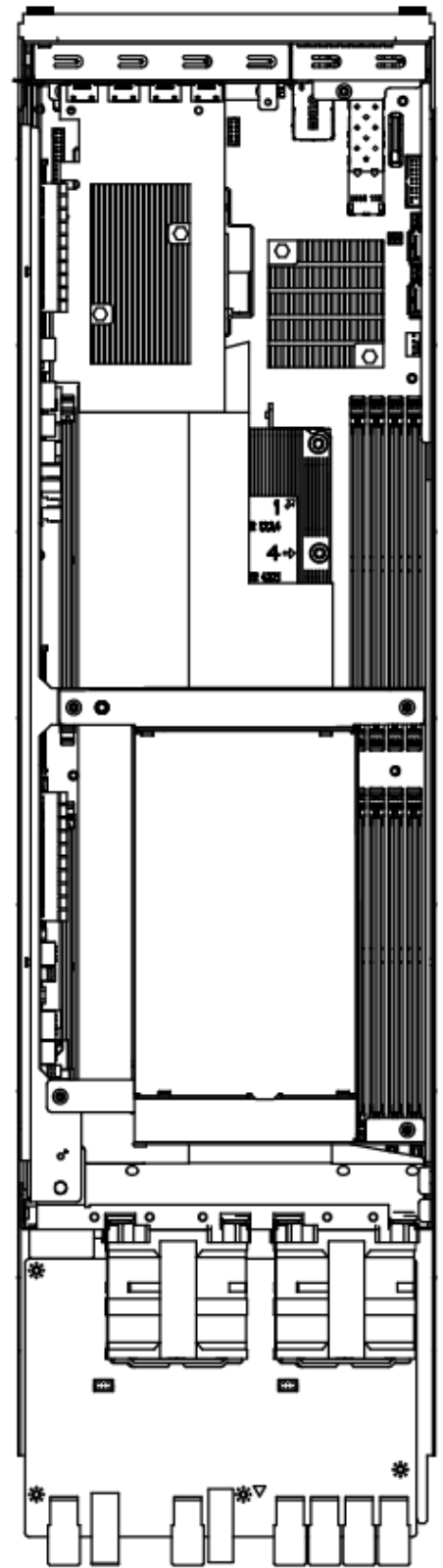

Node top view

Chapter 2. Hardware Setup

2.1 Central Processing Unit Setup

The serverboard supports dual Xeon scalable processors and Socket P0 (LGA-3647).

2.1.1 Processor Installation

To ensure a safe and easy setup, you need to prepare before installation:

- a T20 Torx screwdriver
- ESD wrist strap/mat and conductive foam pad
- Safe and stable environment

CAUTION



The pins of the processor socket are vulnerable and easily susceptible to damage if fingers or any foreign objects are pressed against them. Please keep the socket protective cover on when the processor is not installed.

CAUTION



When unpacking a processor, hold the processor only by its edges to avoid touching the contacts.

Standard Processor Assembly:

A standard processor assembly is comprised of PHM(Processor Heatsink Module) components and processor socket assembly.

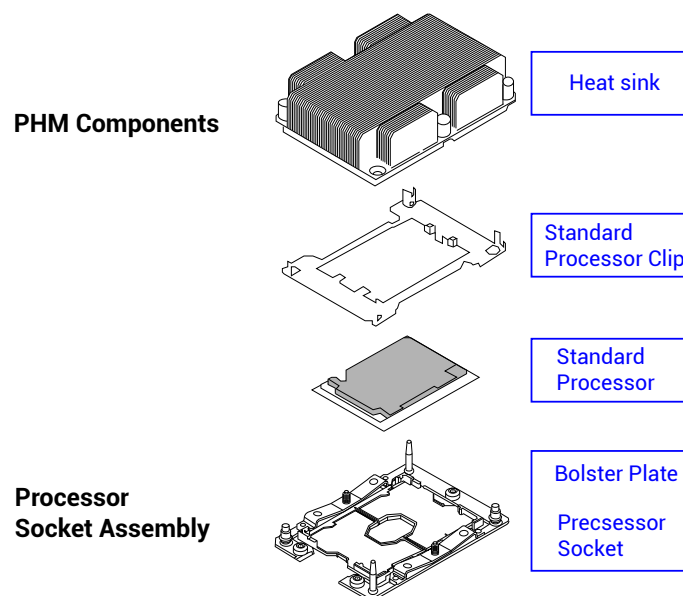

This information is provided for professional technicians only.

Processor Socket Assembly:

The server board includes two processor sockets (LGA-3647), supports one or two of the Intel® Xeon® Processor Scalable Family and has a Thermal Design Power (TDP) of up to 165W on selected models.

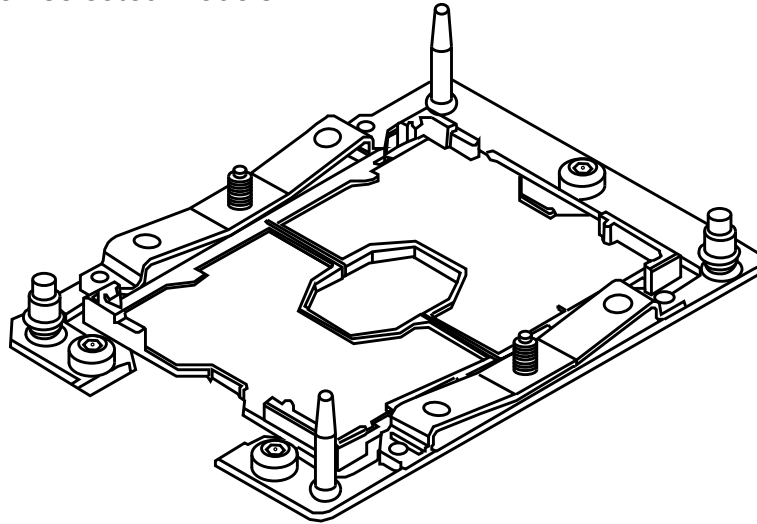

PHM (Processor Heatsink Module) Component:

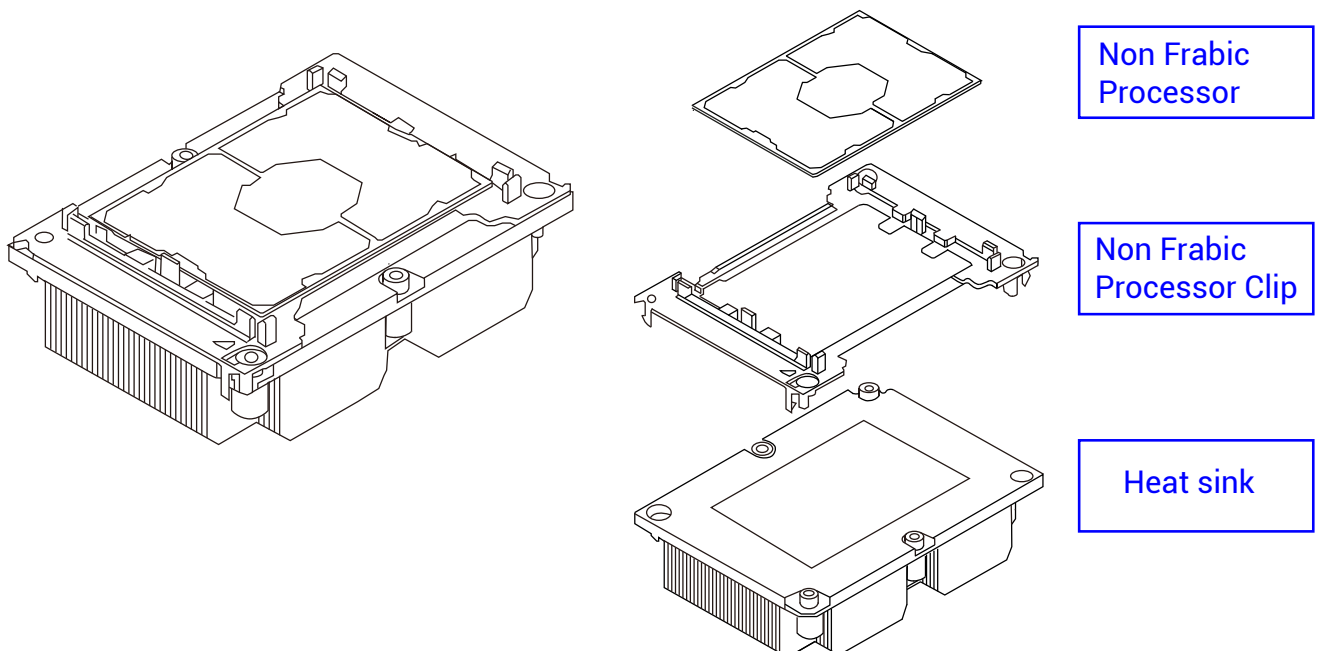

 This information is provided for professional technicians only.

The PHM sits level with the processor socket assembly. The PHM is NOT installed properly if it does not sit level with the processor socket assembly. Once the PHM is seated over the processor socket assembly, the four heat sink torque screws must be tightened in order as shown below.

Processor Heat Sink – Top View with Screw Tightening Order

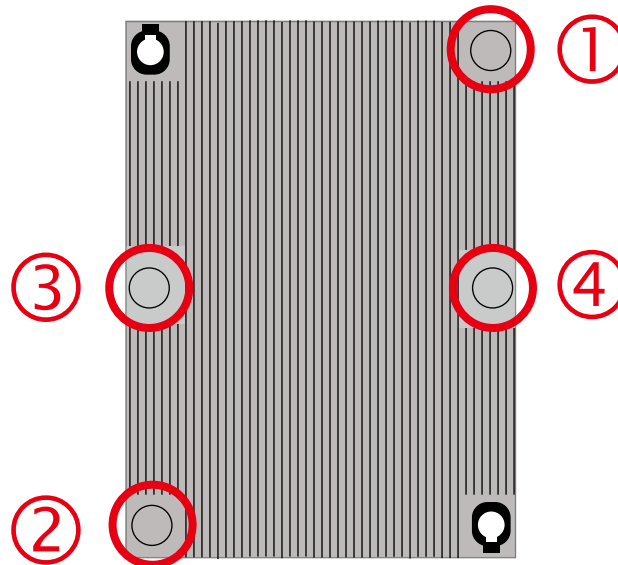

CAUTION



Failure to tighten the heatsink screws in the specified order may cause damage to the processor socket assembly. Heat sink screws should be tightened to 12 in-lbs torque according to the indicated order on the top of the heatsink label.



This information is provided for professional technicians only.

2.2 System Memory

2.2.1 Dual Processor

This server board supports up to sixteen DDR4 2400 and 2666 Registered ECC DRAM/ Load-Reduced DIMM (LRDIMM).

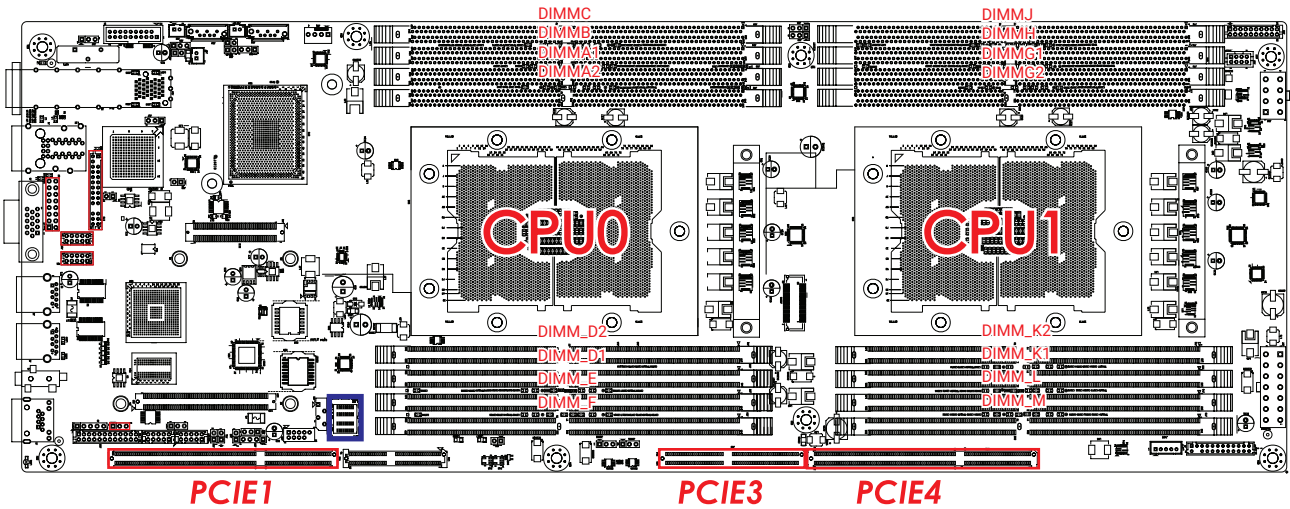

NOTE

 In Pavo Case, the 16 lanes from CPU#0 and the 8 lanes from CPU#1 are routed to PCIe slot1. The lanes from the CPU#1 are routed to the PCIe slot 3 and 4.

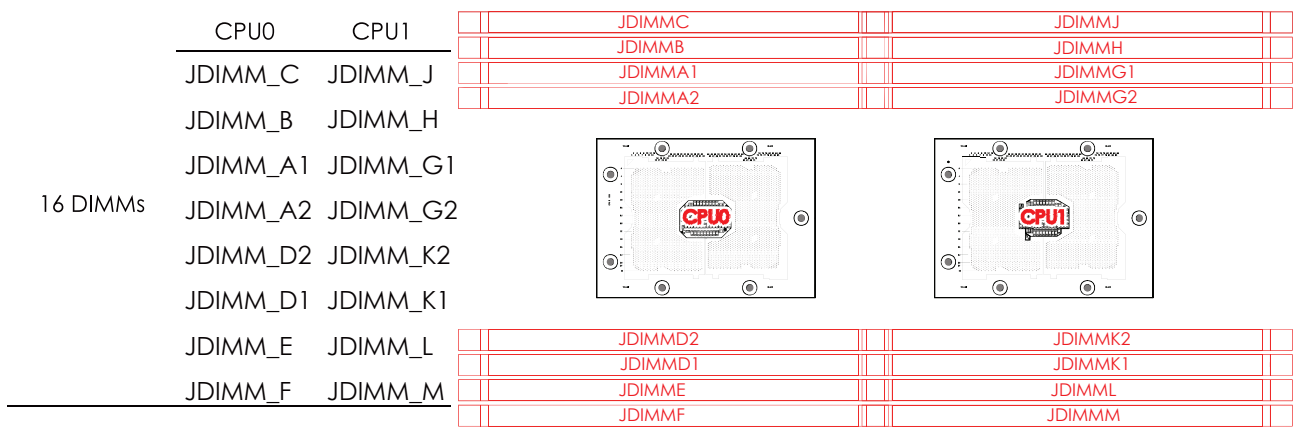
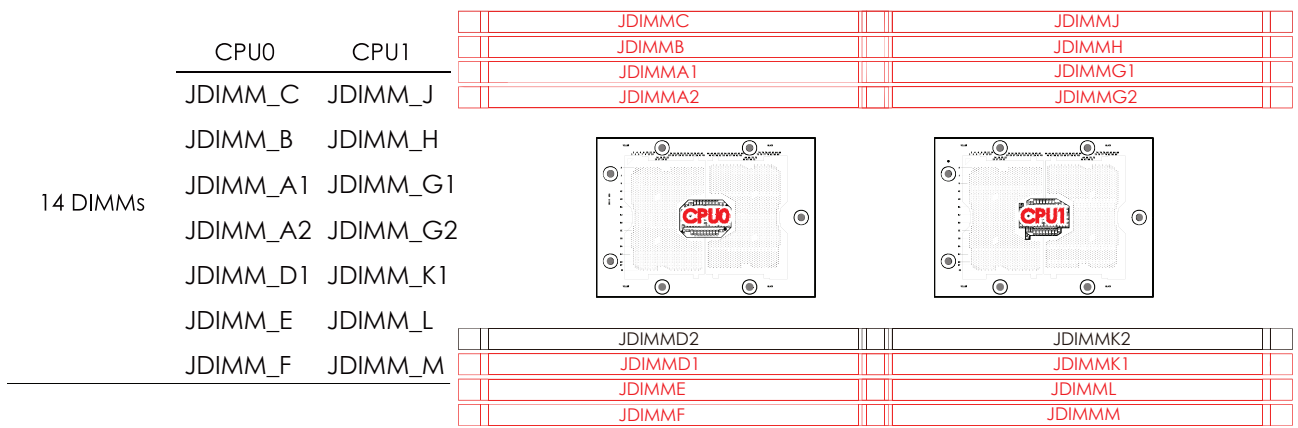
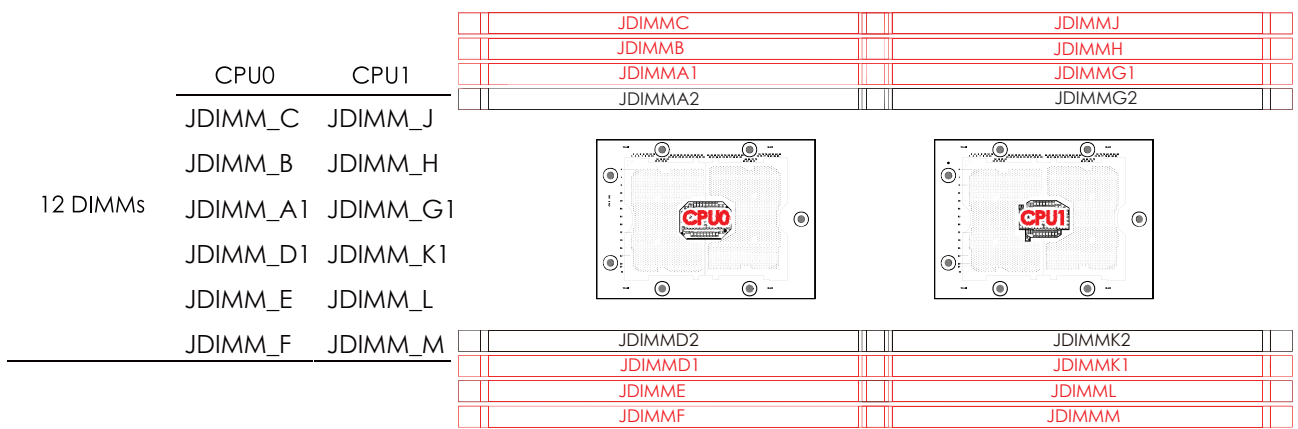
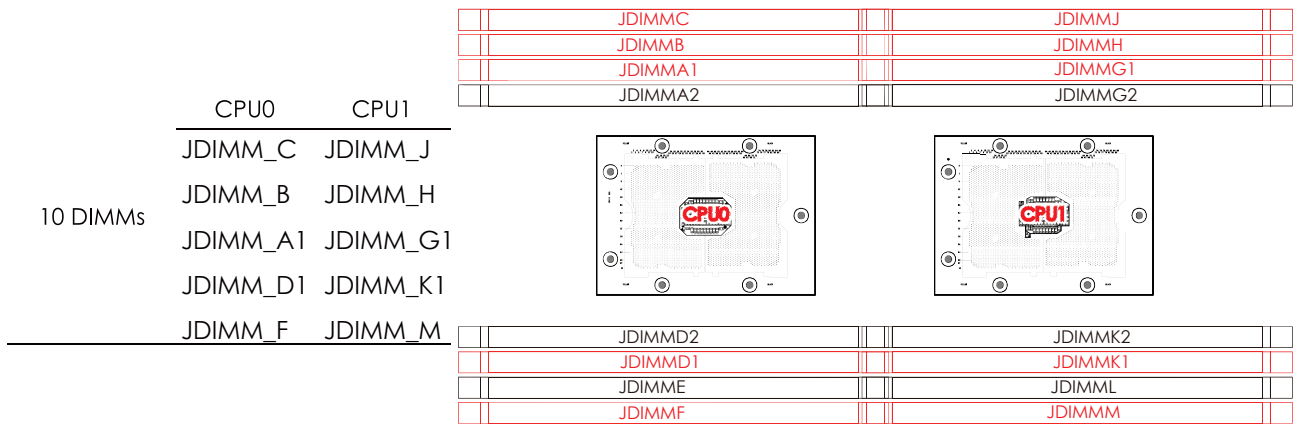

2.2.3 DIMM Installation

Step 1 Unlock the dimm socket by pressing the retaining clips outward.



Step 2 Insert the memory module into the slot. Make sure that the dimm notch is accurately positioned.

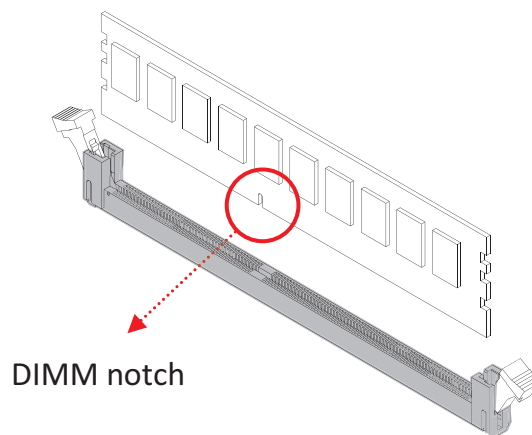

Step 3 Close the retaining clips to complete installation.

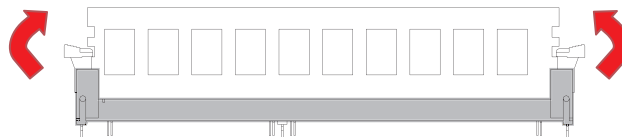

This information is provided for professional technicians only.

2.3 Top Cover

- ① Dislodge the screws on the top cover.
- ② Slide the top cover in the direction of the red arrow.
- ③ Lift the top cover upward to remove.

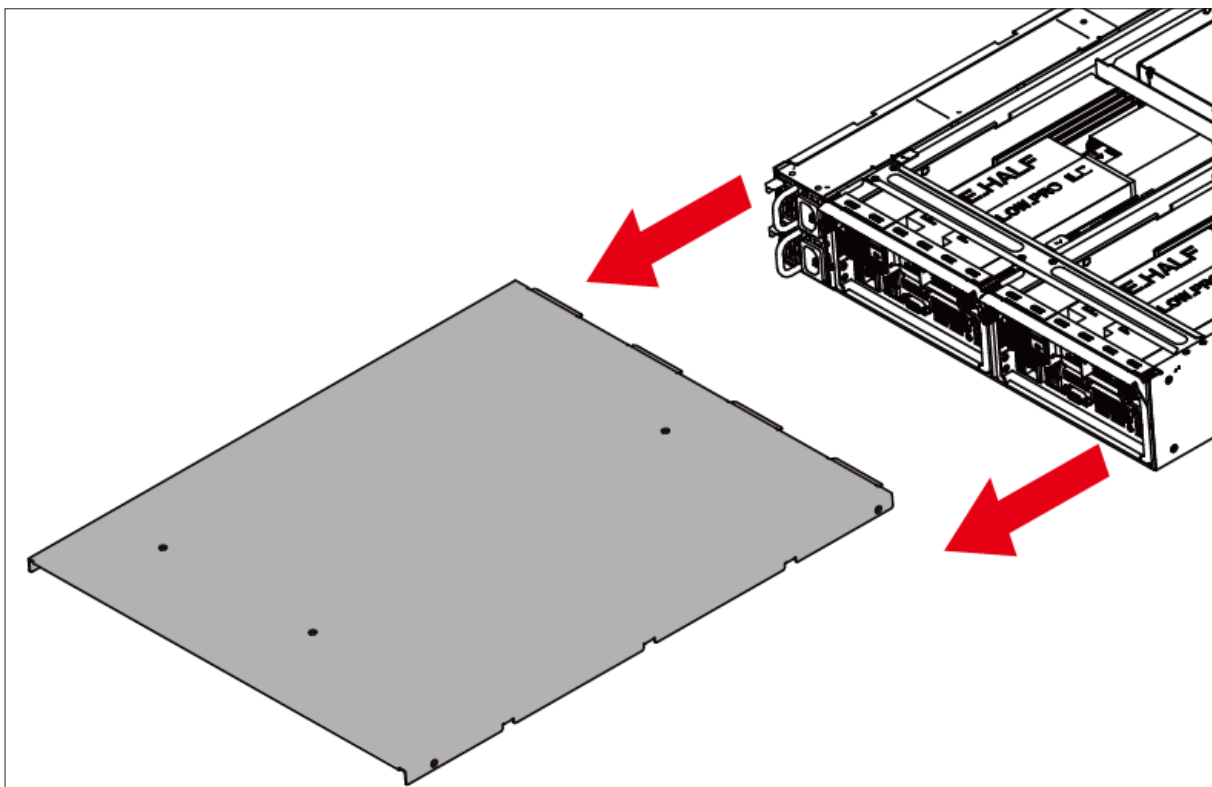
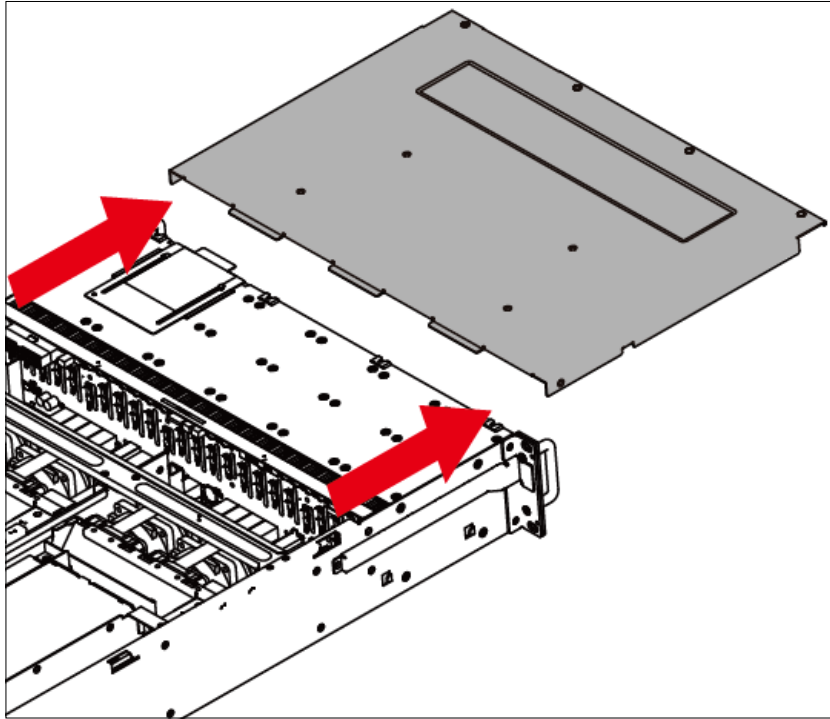

This information is provided for professional technicians only.

2.4 Power Supply Unit Module

- ① Push the ejector to release the module.
- ② Pull the handle to remove the module out of the chassis.
- ③ Push the replaced power supply unit into the chassis. Ensure that the module is hooked into the cage.

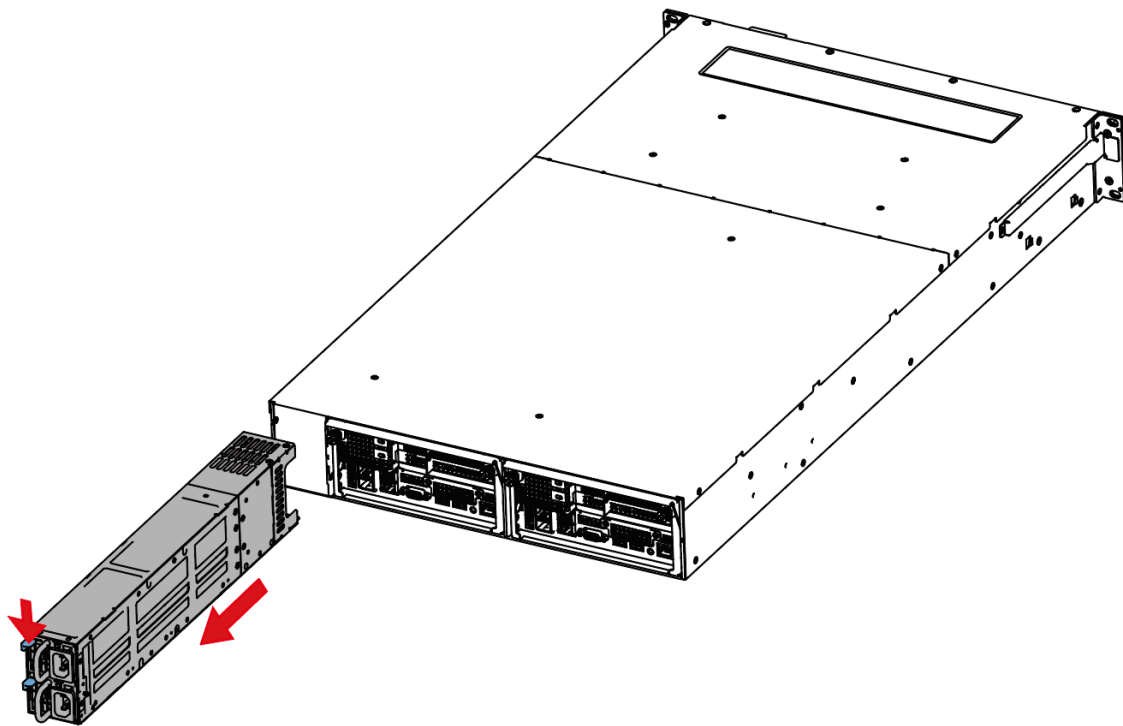

This information is provided for professional technicians only.

2.5 Node

- ① Loosen the captive screw to release the handle.
- ② Pull the handle to remove the module out of the chassis.
- ③ Push the replaced node completely into the chassis.
- ④ Close the handle and tighten the captive screw to secure the node.

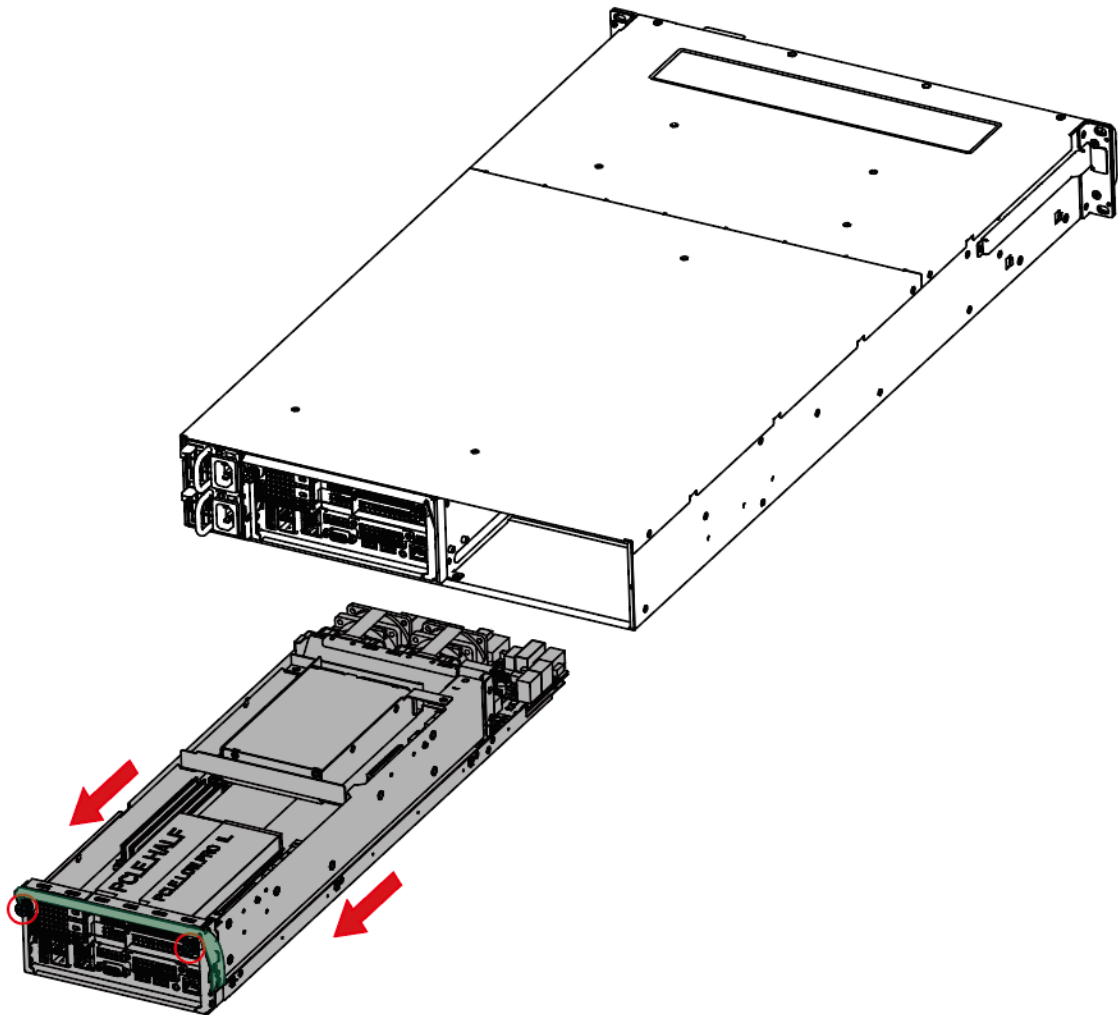

This information is provided for professional technicians only.

2.6 Fan Module

- ① Initiate the removal of the fan by unplugging the cables and connectors from the fan.
- ② Extract the fan by carefully dislodging the rubber connectors on the fan from the securing bracket.
- ③ Insert the new fan into the chassis by verifying the alignment of the rubber connectors and bracket.

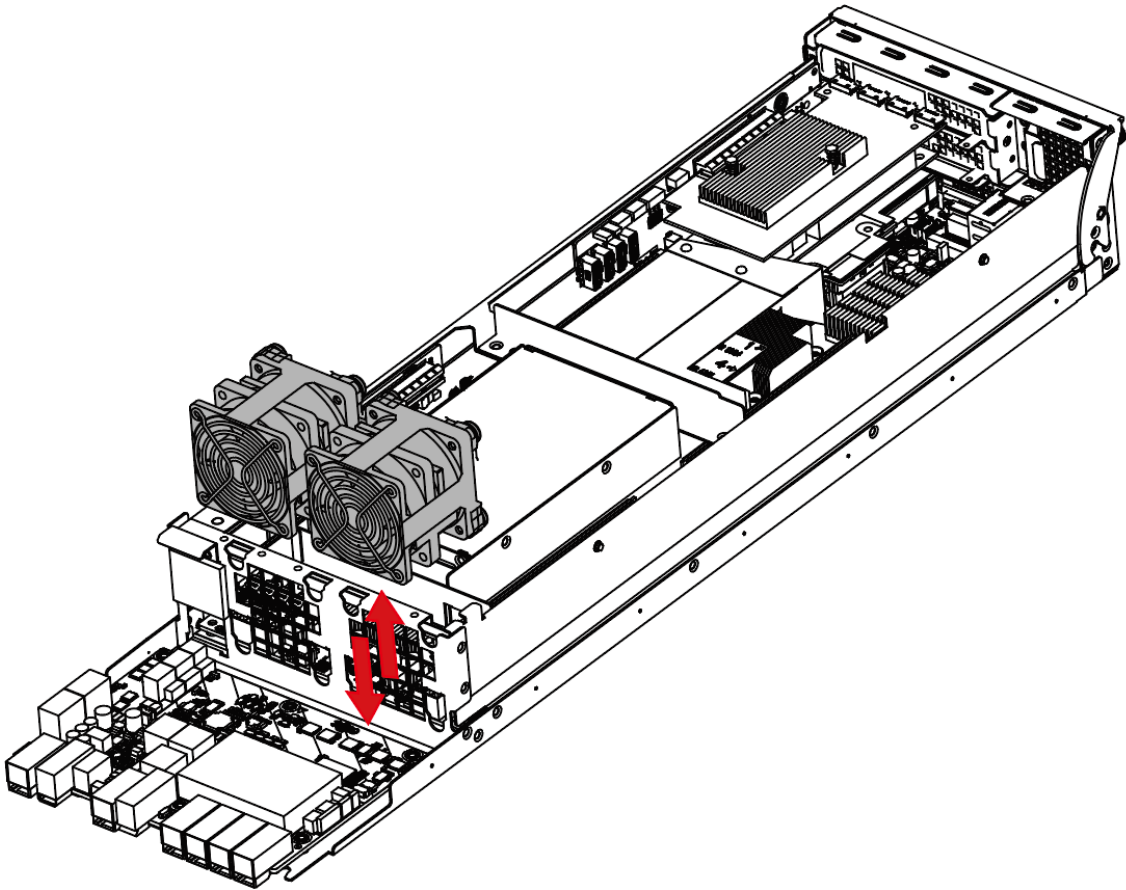

This information is provided for professional technicians only.

2.7 Hard Disk Drive

- ① Press the release button the tray lever to loosen the lever.
- ② Pull the tray lever outward completely.
- ③ Pull the tray out of the system.

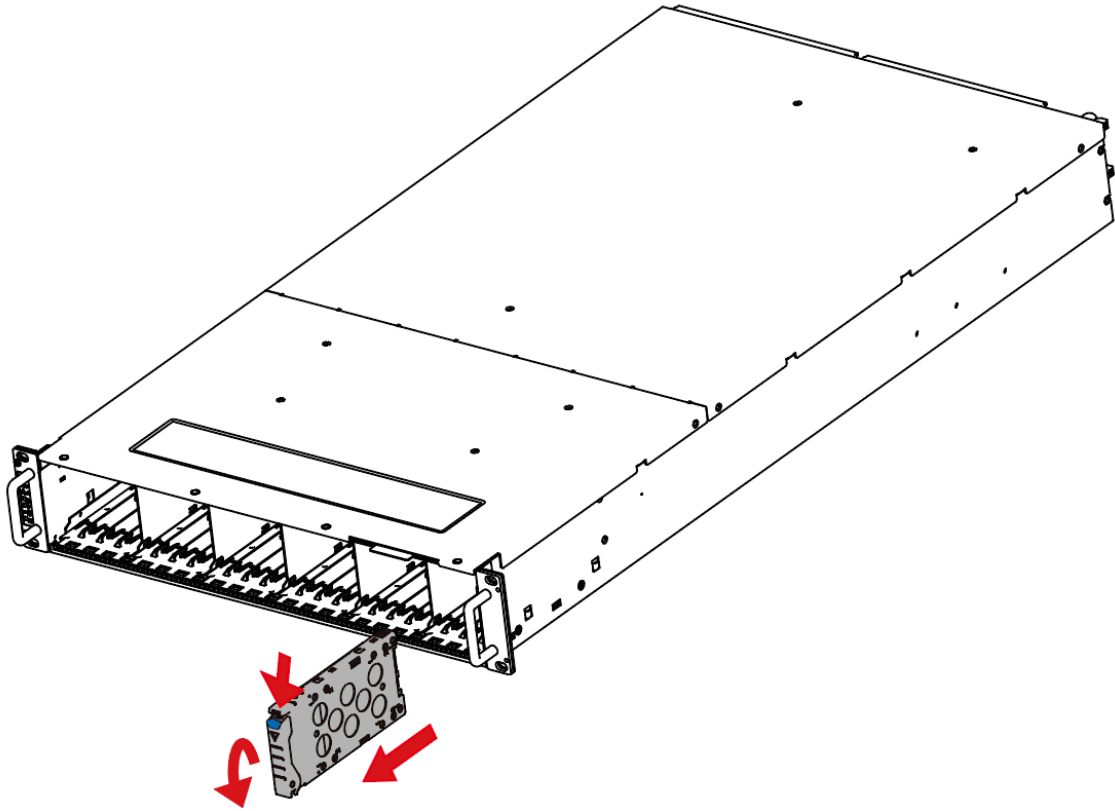

- ④ Insert the hard disk drive into the tray. Ensure that the dimples on the tray match the hard disk drive. For additional assurance, fasten the screws x 2 on the drive tray to secure the hard disk drive.

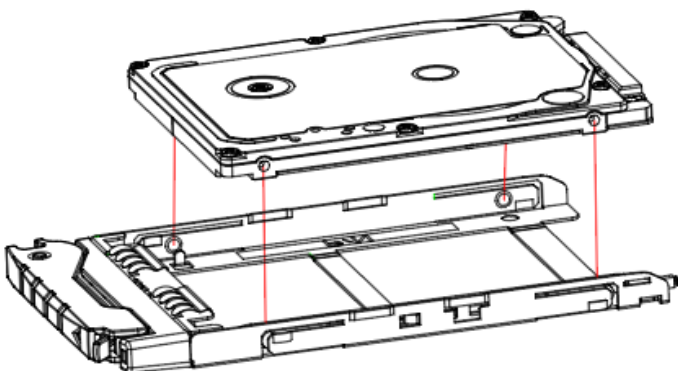

2.5" HDD dimple location

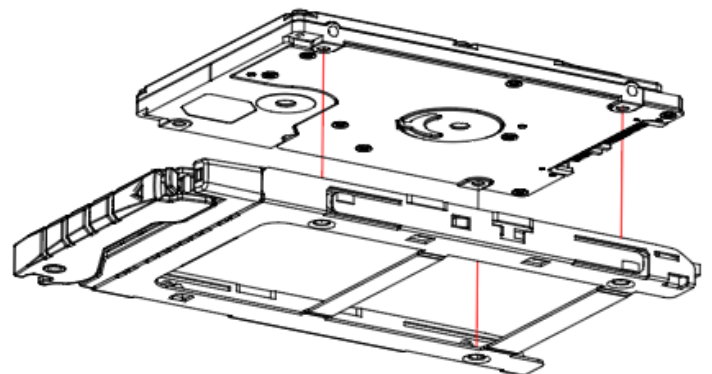

2.5" HDD screw location



This information is provided for professional technicians only.

2.8 HDD Backplane Module

- ① Detach the cables and hard disk drives from the backplane module.
- ② Release the module by shifting the hook.
- ③ Dislodge the screws on the module.
- ④ Lift the module upward to remove.

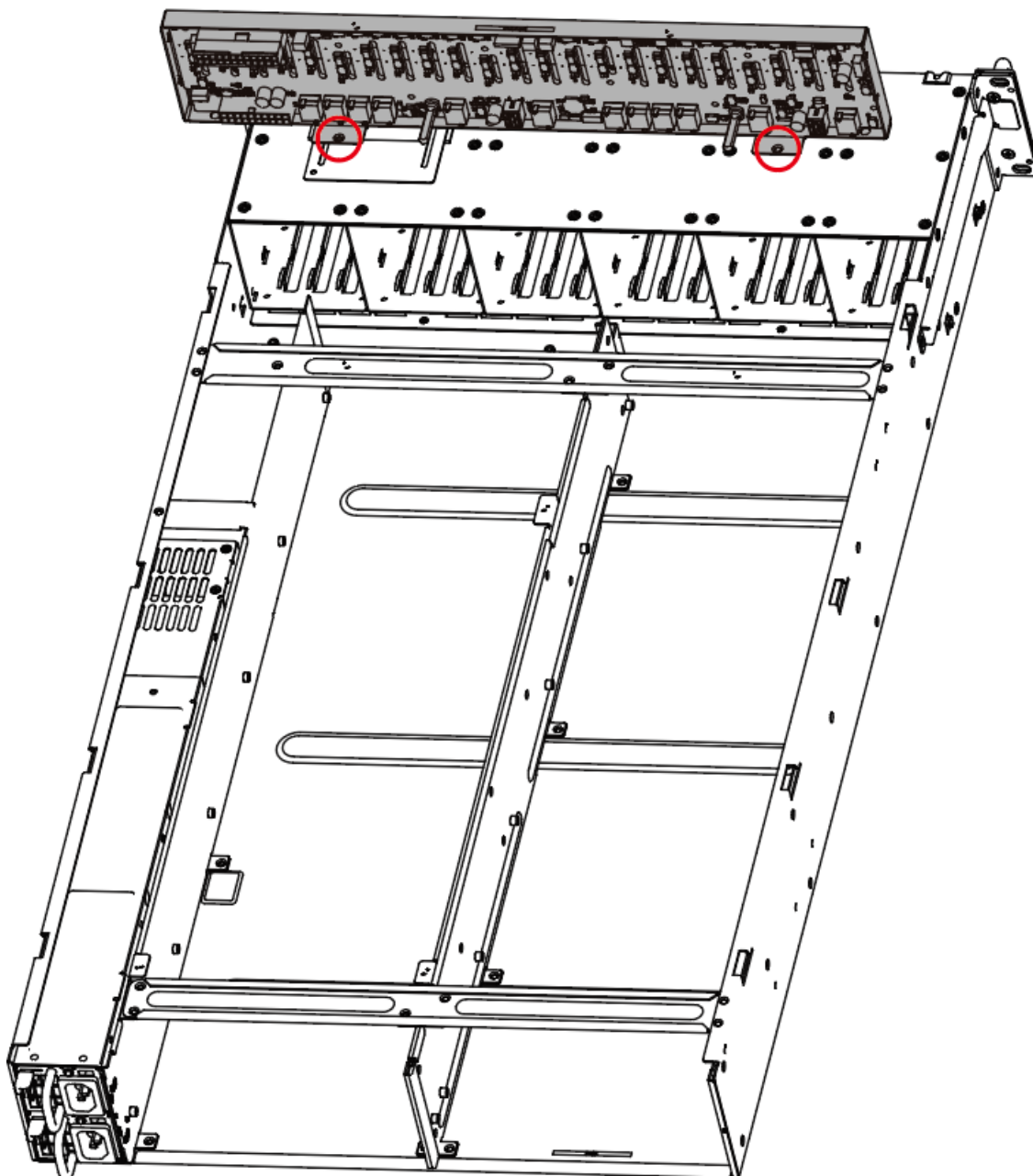

This information is provided for professional technicians only.

2.9 Slide Rail Installation

- ① Removing the inner slide rail. Pull the slide rail open by pressing the trigger downward.

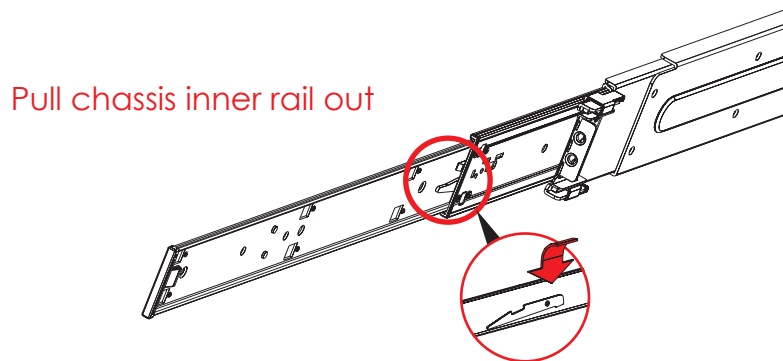

Press the trigger down to release

- ② Mounting the inner side of the slide rail. Align the rectangular holes on the inner side of the chassis with the bayonets on the side of chassis. Secure the inner chassis with screw form in a standard screw kit after the bayonets go through the holes and are accurately positioned.

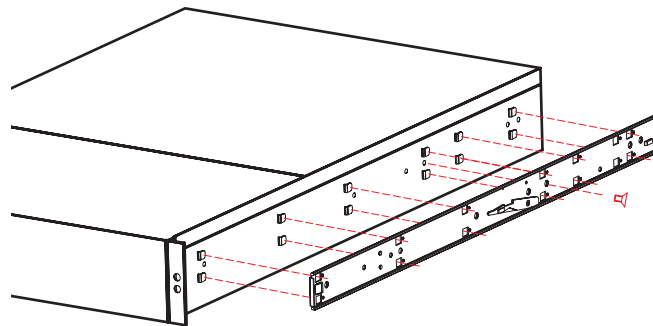

Bayonet on chassis shall be pre-formed as per the recommended dimension and location.

③ Attach the outer of cabinet to the slide rail.

Insert the stag into the upper and lower square holes on rail from the back of rail. Push the safety lock forward to secure the bracket. Be certain to check if the safety lock is in disengaged position before mounting the brackets.

Release safety lock before mounting

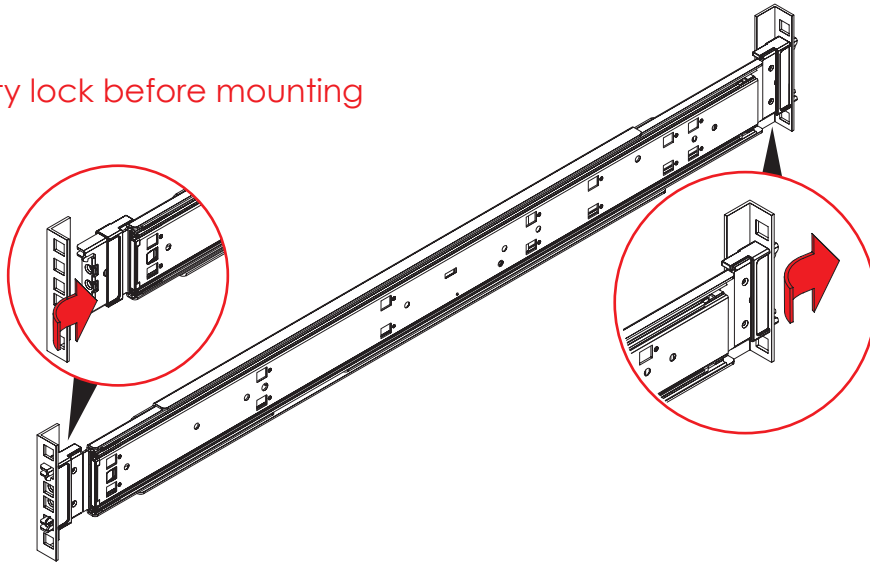

Push the safety lock forward to secure

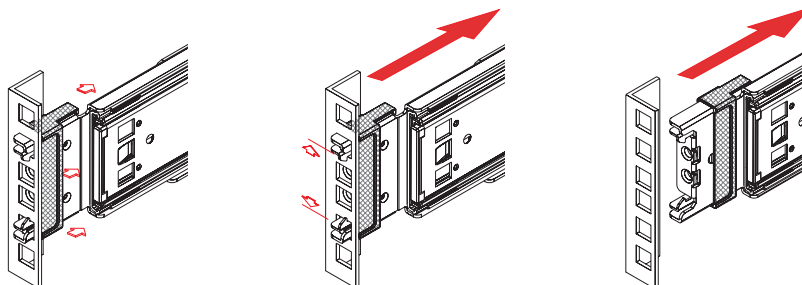

④ Mount the chassis into the cabinet.

Insert the inner side of chassis into the cabinet. Check if the ball retainer is fully opened before installing the chassis. It may cause catastrophic damage to the chassis if ball retainer is not in fully open position while mounting the chassis. While you are pushing chassis back into the cabinet, release the slide from locking position by pressing the trigger downward.



WARNING

It requires at least 2 people to install the chassis for safety purpose.

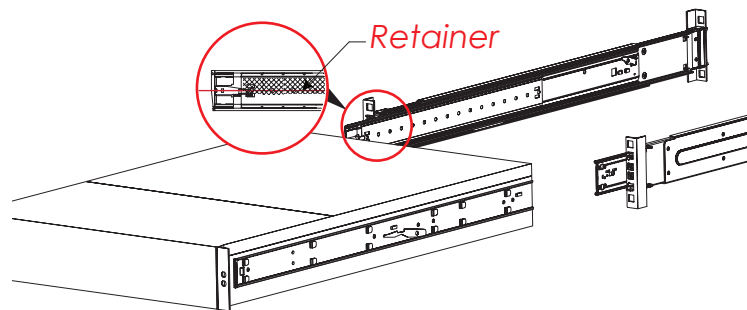

This information is provided for professional technicians only.

Chapter 3. Motherboard Settings

This section describes the jumpers, internal connectors, and internal LED settings on the Pavo motherboard. The motherboard layout and jumper settings are listed below.

3.1 Block Diagram

PAVO Block Diagram

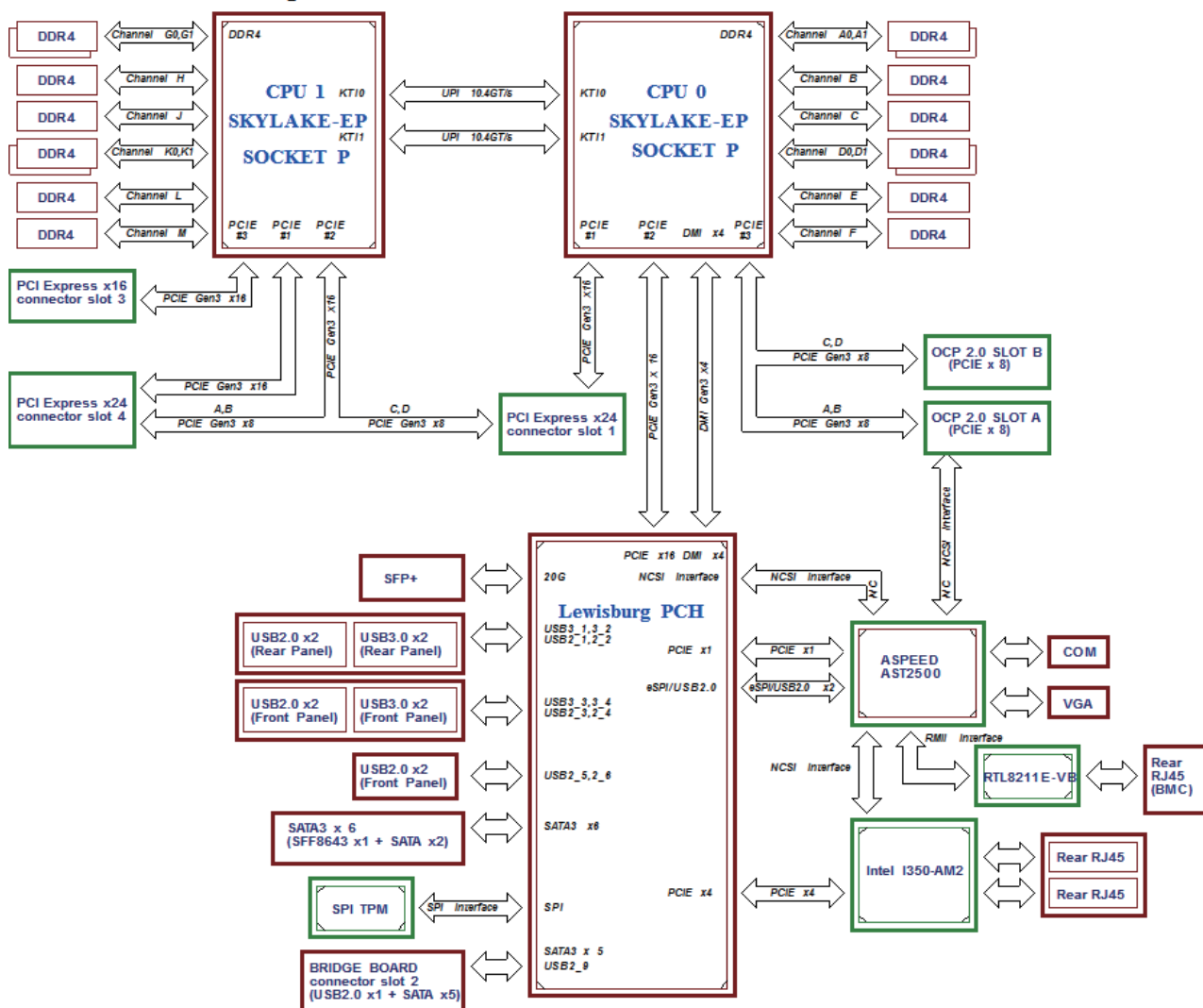

3.2 Content List

Connector and Header		Location	Connector and Header		Location
1	RJ45 Port for BMC management		22	PMBUS Header	
2	COM Port by 3.5mm Phone Jack		23a 23b	PCIe Slot (x24)	
3a 3b	2 x USB 3.0 Type A Connector	J5 J6	24	PCIe Slot (x16)	
4	VGA Port		25	PCIe Hot-Plug SMB Header (CPU0)	
5a 5b	2 x GbE RJ45 Port		26	PCIe Hot-Plug SMB Header (CPU1)	
6a 6b	2 x 10GbE SFP+ Port		27	All Node Off Header	
7a 7b	COM Header	J11 J12	28	Bridge Board Connector	
8	Front VGA Header	J7	29	Serial ATA Connector	
9	UID LED Header	J15	30	IPMB Header	
10	Battery Socket	BAT1	31	Front I/O USB 2.0 Header	
11	Front I/O USB 3.0 Header	J16	32	BMC ROM Socket	
12	UART Header	J17	33	SPI ROM Socket	
13a 13b	SATA-DOM Power Connector	J22 J42	34	BMC IPMB Header	
14	Intruder Header	J47	35	PECI Header	
15a 15b	Serial ATA Connector	J33 J34	36	Speaker Header	
16	OCP Card Slot A	J41	37	PCH SSGPIO Header	
17	BMC Fan Header	J51	38	VRM SMB Header	
18	Front BMC GPIO Header	J40	39	PCH SGPIO Header	
19	VDR Supply Connector (2 x 4 pin)	J86	40	OCP Card Slot A	
20	Power Supply Connector (2 x 7 pin)	J87	41	Front System Fan Header	
21	Front Panel Header	J81	42	LCM Header	

Jumper		Location	Jumper		Location
A	Clear CMOS Jumper	J10	G	SATA DOM Jumper	J43
B	BMC Reset Jumper	J23	H	Password Clear	J31
C	Flash Security override	J21	I	BMC Disable Jumper	J30
D	SATA DOM Jumper	J20	J	XDP Port CPU0 Bypass Chain Control	J83
E	ME Recovery Mode	J35	K	XDP Port CPU1 Bypass Chain Control	J84
F	BIOS Recovery Mode	J37			

3.3 Placement

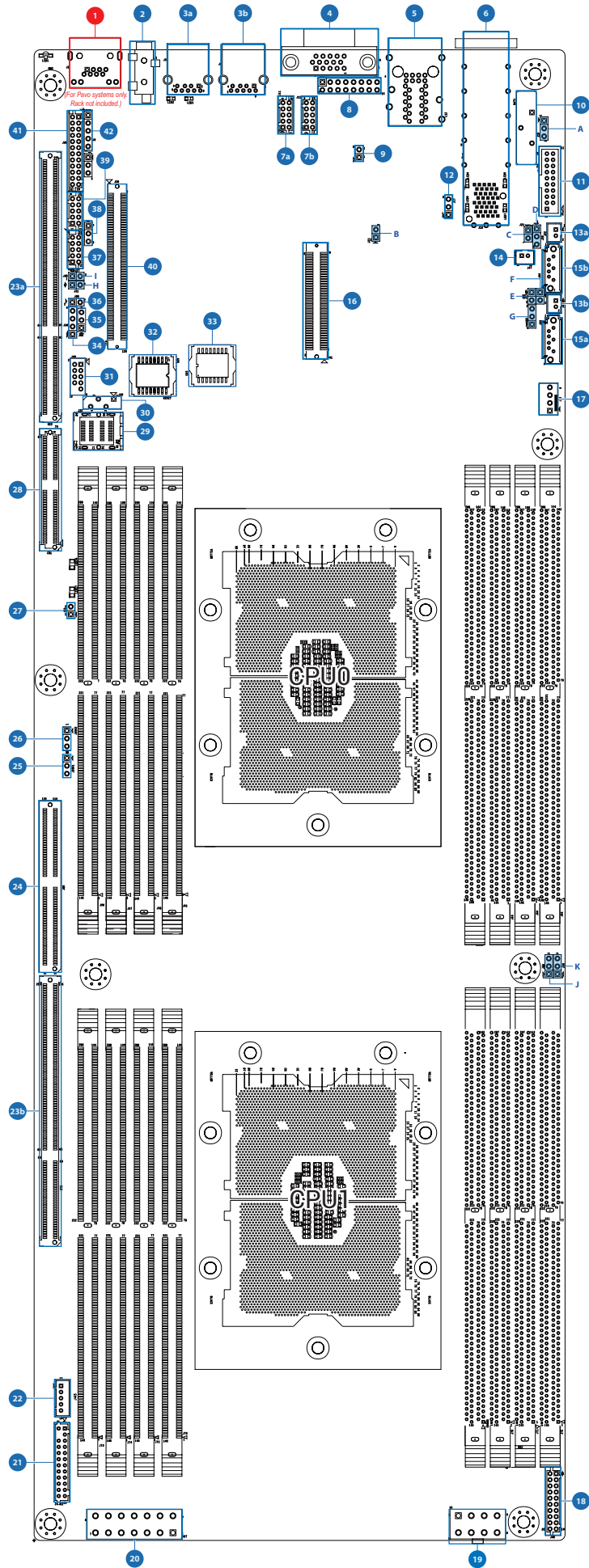

3.4 Connector and Jumper

- ⑦a~⑦b COM Header (J11, J12) ⑧ Front VGA Header (J7) ⑨ UID LED Header (J15)

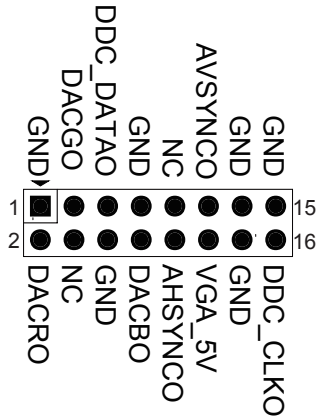
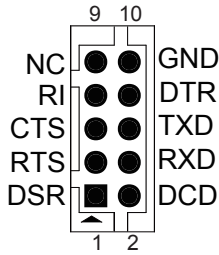

- ⑫ UART Header (J17)

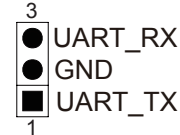

- ⑪ Front I/O USB 3.0 Header (J16)

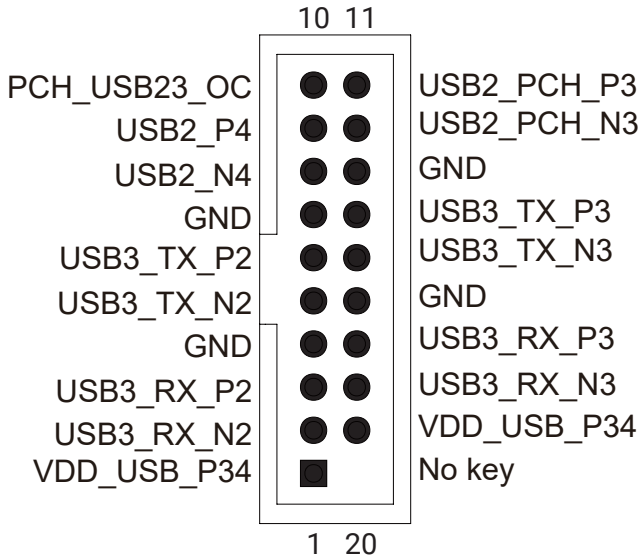

- ⑬a~⑬b SATA DOM Power Connector (J22, J42)



- ⑭ Intruder Header (J47)

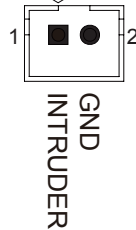

NOTE
To enable chassis intrusion function in J47, you must configure J40 pin 17 and pin 19 to short pin.

- ⑰ BMC Fan Header (J51)

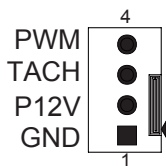

- ⑱ Front BMC GPIO Header (J40)

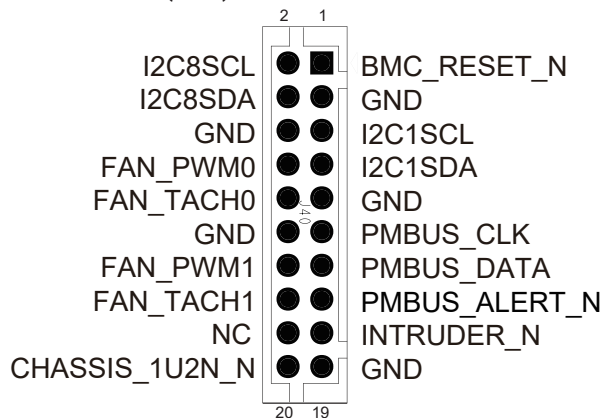

- ⑲ VRD Supply Connector (J86)

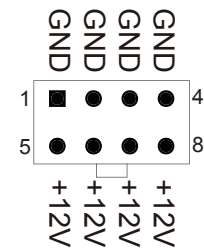

- ⑳ Power Supply Connector (J87)

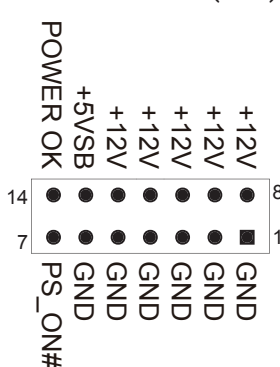

②② Front Panel Header (J81)

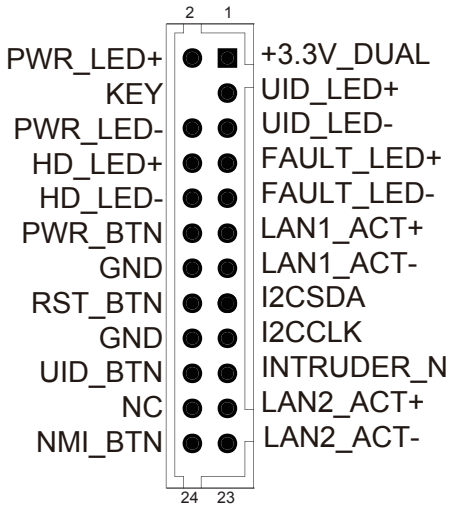

②⑤ PCIe Hot Plug SMB Header (J2001)

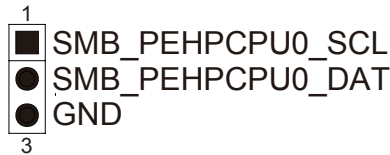

②⑥ PCIe Hot Plug SMB Header (J2002)

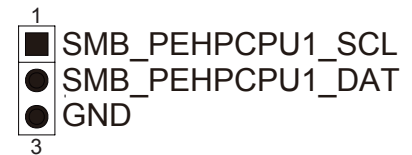

③① IPMB Header (J46)

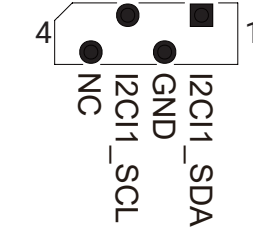

③② Front I/O USB 2.0 Header (J49)

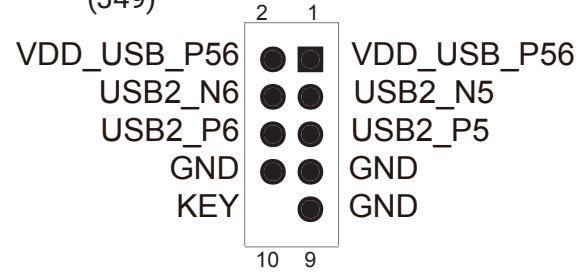

③⑤ BMC IPMB Header (J36)

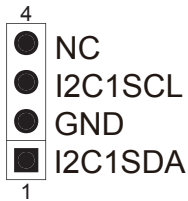

③⑦ Speaker Header (J48)



③⑧ PCH SSGPIO Header (J27)

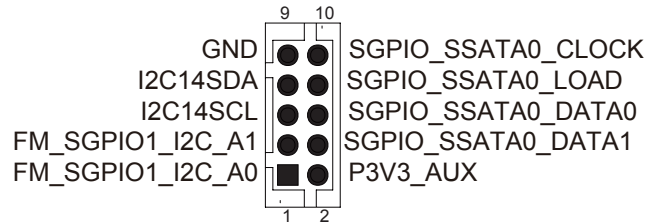

③⑨ VRM SMB Header (J24)

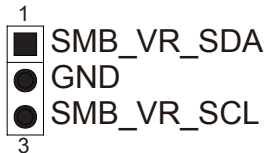

④① PCH SGPIO Header (J18)

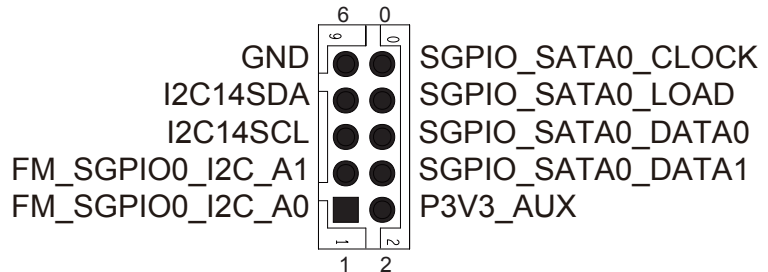

④② Front System Fan Header (J39)

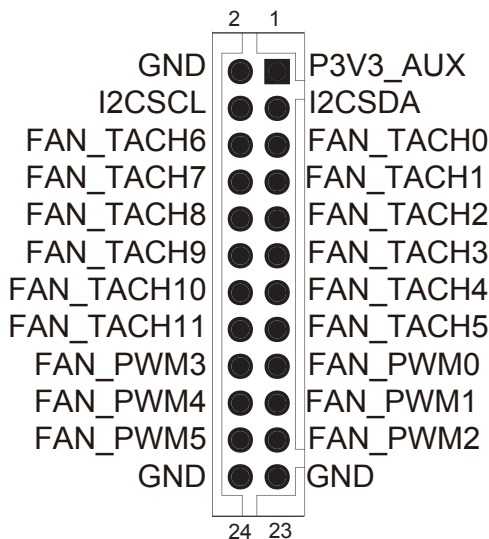

④③ LCM Header (J9)

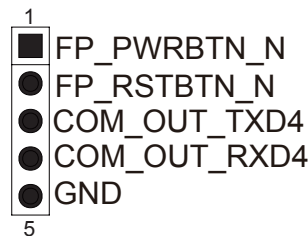

(A) Clear CMOS Jumper (J10)



J10	Setting	
Pin 1-2	Normal	Default
Pin 2-3	Clear CMOS	

(E) ME Recovery Mode Jumper (J35)



J35	Setting	
Short	ME Recovery Mode	
Open	Normal	Default

(B) BMC Reset Jumper (J23)



J23	Setting	
Short	BMC Reset	
Open	Normal	Default

(F) BIOS Recovery Mode Jumper (J37)



J37	Setting	
Short	BIOS Recovery Mode	
Open	Normal	Default

(C) Flash Security override Jumper (J21)



J21	Setting	
Short	Flash Security override	
Open	Normal	Default

(H) Password Clear Jumper (J31)



J31	Setting	
Short	Password Clear	
Open	Normal	Default

(D) SATA DOM Power Jumper (J20)

(G) SATA DOM Power Jumper (J43)



J20, J43	Setting	
Pin1-2	SATA	Default
Pin2-3	SATA DOM	

(I) BMC Disable Jumper (J30)



J30	Setting	
Short	BMC Disable	
Open	Normal	Default

NOTE



When the SATA DOM jumper is set, +5V will be delivered to the 7th pin of the SATA connector.

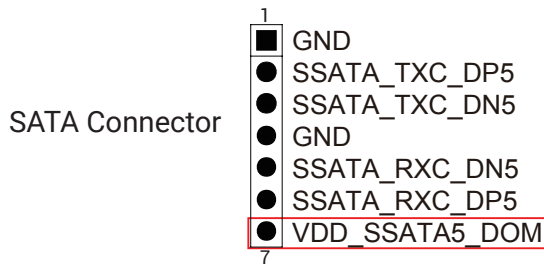

NOTE



- If the SATA DOM is supplied to the motherboard, set the jumper to pins 2-3.
- If the SATA DOM is supplied by the external power, set the jumper to pins 1-2.
- If a SATA type hard drive is connected to the motherboard, please ensure that the jumper is closed and set to pins 1-2 (Default setting) to reduce the risk of hard disk damage.

SATA DOM PWR Jumper (J20)

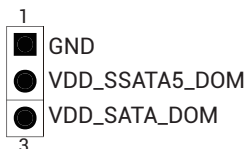

SATA DOM PWR Jumper (J43)

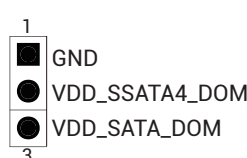

ⓐ XDP Port Setting
CPU0 Bypass chain control (J83)



J83	Setting	
Pin 1-2	Force Bypass of CPU0	
Pin 2-3	Normal	Default

ⓑ XDP Port Setting
CPU1 Bypass chain control (J84)



J84	Setting	
Pin 1-2	Force Bypass of CPU1	
Pin 2-3	Normal	Default

3.5 System LED Indicator

3.5.1 Front Panel

Power	Yellow	System is On.
	Blinking	System is in Standby; System is off, but has AC power.
	Off	System has no AC power.
System ID	Blue	System ID activity is detected.
	Off	No System ID activity is detected.
System Fault	Red	Critical system failure is detected (processors, memory, voltage regulators, thermal events, fan failures, NMI, etc).
	Off	No critical failures are detected.
Hard Disk	Green (Blinking)	Disk activity is detected.
	Off	No disk activity is detected.
LAN1_TRAFFIC	Green (Blinking)	LAN1 activity is detected.
	Off	LAN1 is not active.
LAN2_TRAFFIC	Green (Blinking)	LAN2 activity is detected.
	Off	LAN2 is not active.

3.5.2 Rear I350 LAN

The NIC Port LED should be connected to Vaux (standby) voltage.

Description		Left LED (LED4, LED2,) (Link/Activity)	Right LED (LED3, LED1) (Speed)
No Link		OFF	OFF
Linked at 10 Mbps	Link	Green	OFF
	Active	Blinking Green	OFF
Linked at 100 Mbps	Link	Green	Green
	Active	Blinking Green	Green
Linked at 1000 Mbps	Link	Green	Yellow
	Active	Blinking Green	Yellow

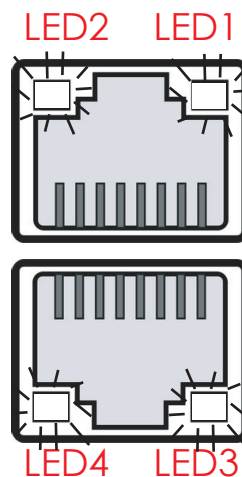

3.5.3 Rear PCH LAN

LED5	Green	LAN1 activity is detected.
	Off	LAN1 is not active.
LED7	Green	LAN1 link is detected.
	Off	LAN1 is not linked.
LED6	Green	LAN0 activity is detected.
	Off	LAN0 is not linked.
LED4	Green	LAN0 link is detected.
	Off	LAN0 is not active.

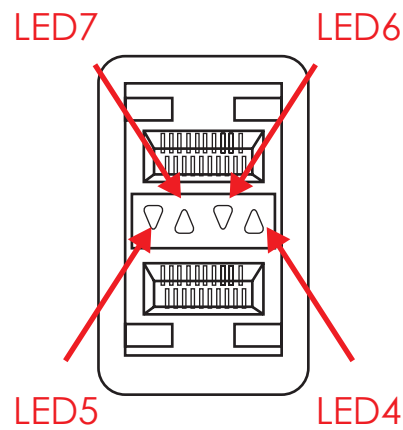

3.5.4 Rear UID and Internal LED

LED1	On	UID activity is detected.
	Off	UID is not active.
LED2	On	BMC Rack LAN activity is detected (Only for Rack).
	Off	BMC Rack LAN is not active (Only for Rack).
LED3	On	BMC Rack LAN activity is detected (Only for Rack).
	Off	BMC Rack LAN is not active (Only for Rack).
LED18	Blinking	BMC is working.
	Off	BMC is not working.

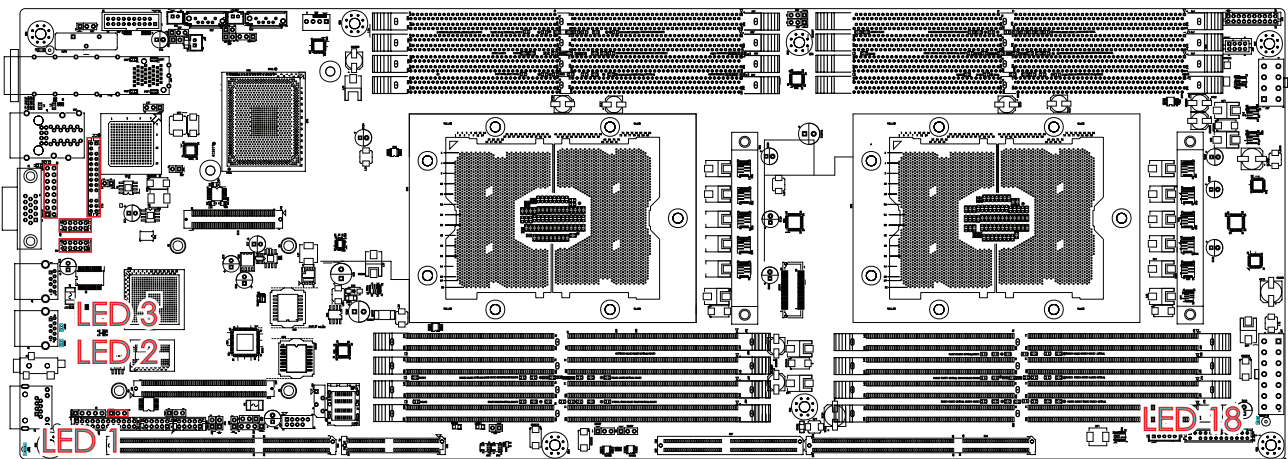

3.6 HDD Backplane

3.6.1 Placement

Top view

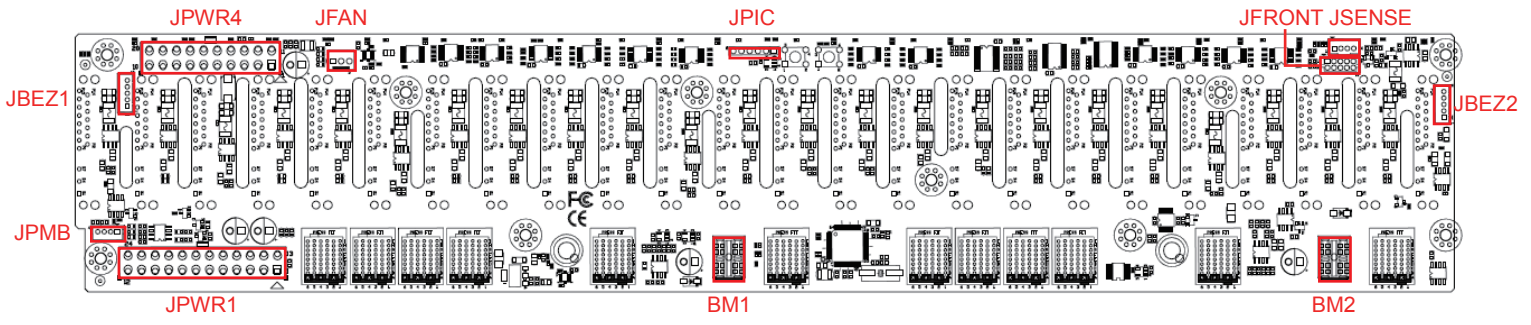

Bottom view

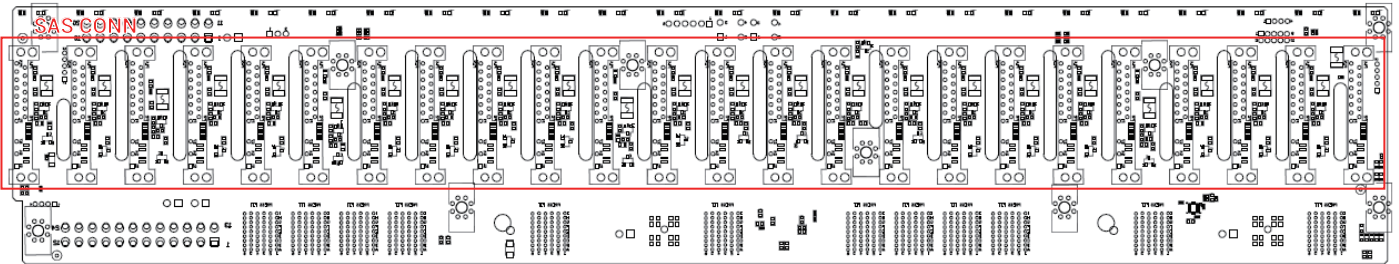

3.6.2 Connector and Jumper

Power Supply Connector (JPWR4)

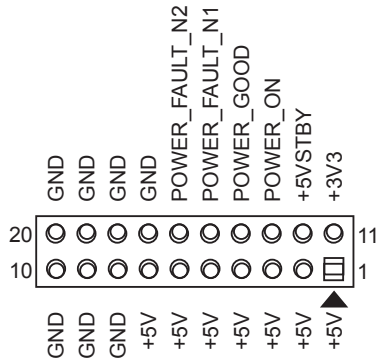

Power Supply Connector (JPWR1)

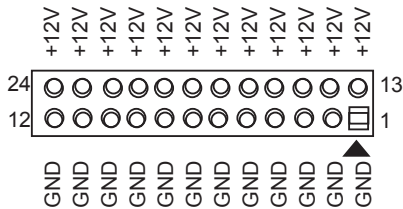

Power IPMB Function (JPMB)

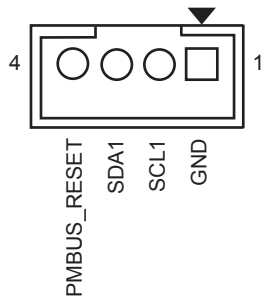

FAN Control (JFAN)

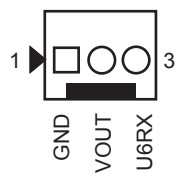

PIC I2C function (JPIC)

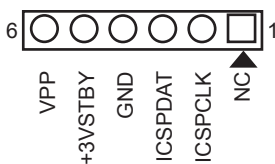

12V Output power connector (BM1,BM2)

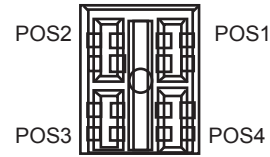

Front panel function connector (JFRONT)

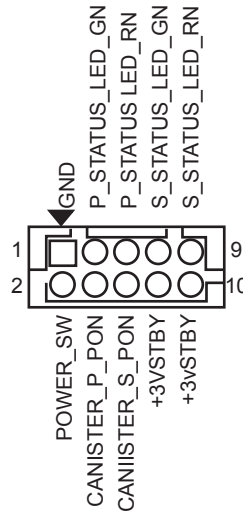

Bezel function (JBEZ1,JBEZ2)

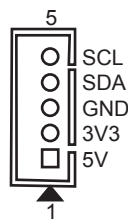

Power sense control (JSENSE)

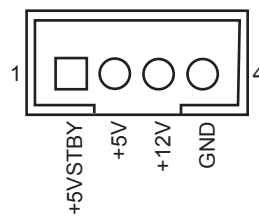

3.7 Expander

3.7.1 Placement

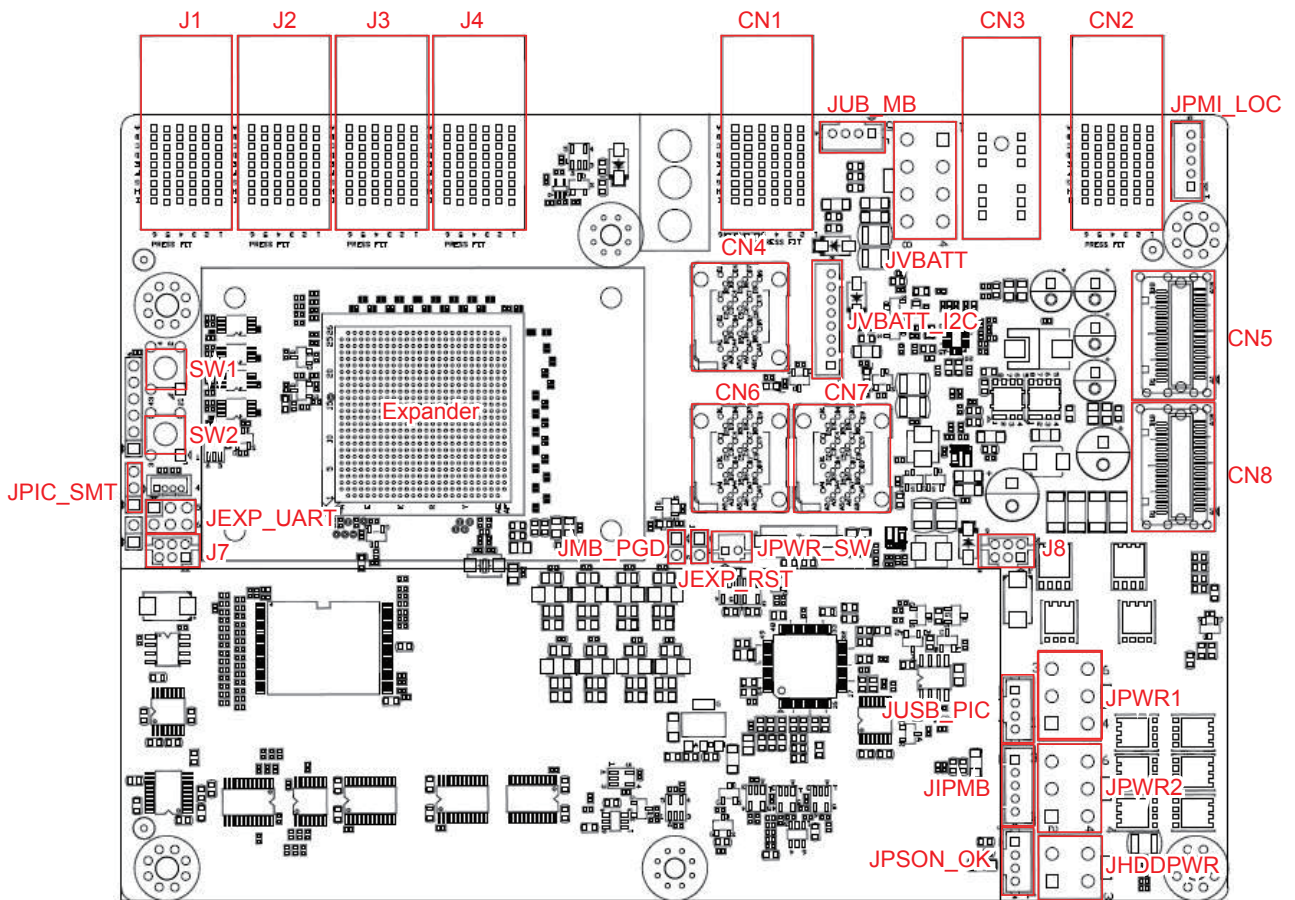

3.7.2 Connector and Jumper

Backplane PIC USB Header (JUSB_MB)

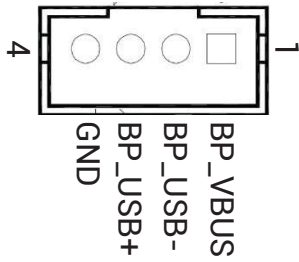

Battery Connector (JVBATT)

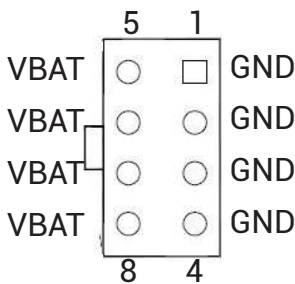

IPMB for Device (JIPMI_LOC)

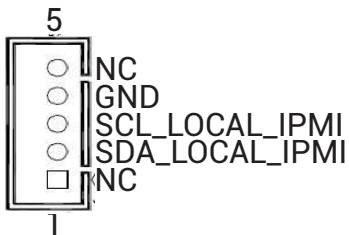

Battery Function (JVBATT_I2C)

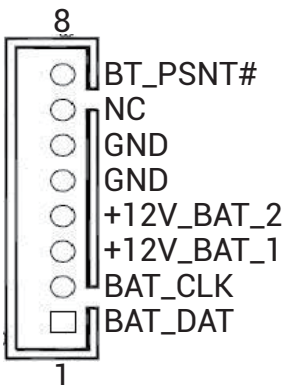

Fan Connector

(J7)

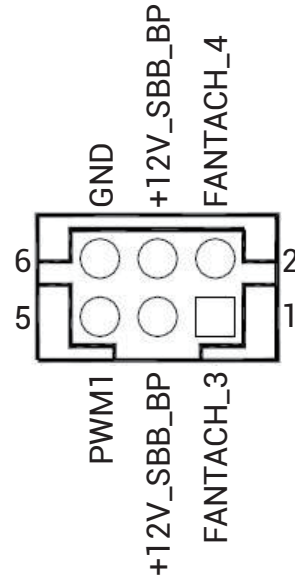

(J8)

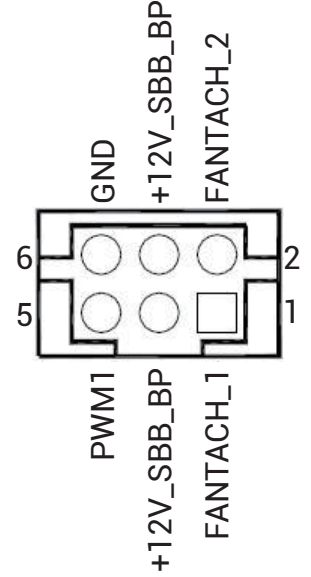

Power Connector (JPWR1, JPWR2)

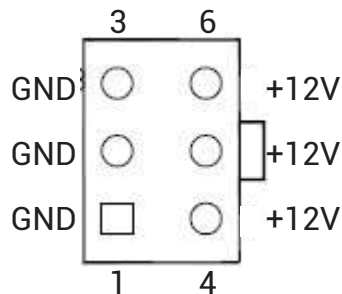

OS HDD Power Connector (JHDDPWR)

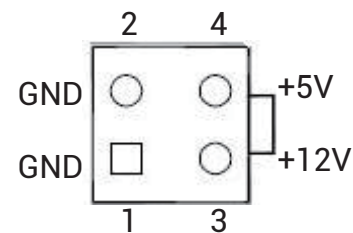

PIC USB (JUSB_PIC)

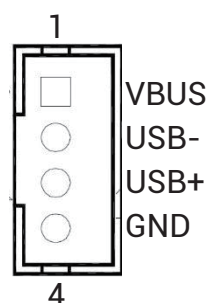

IPMB Connector (JIPMB)

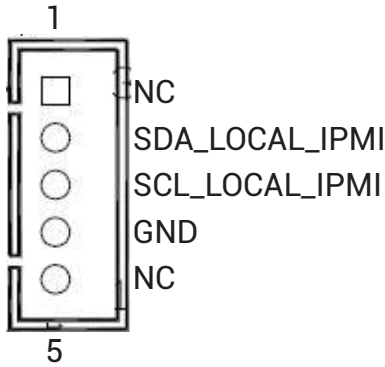

Console for Expander (JEXP_UART)

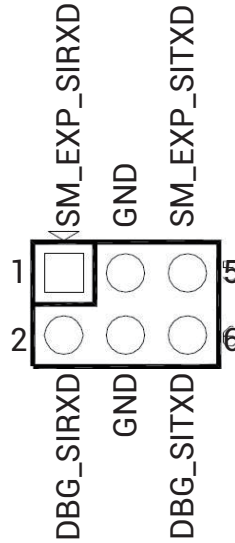

Motherboard power on function (JPSON_OK)

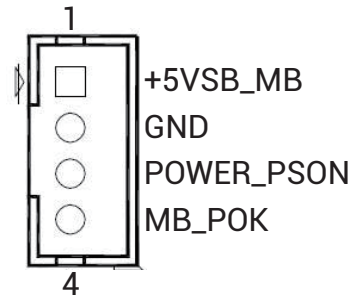

PIC Smart port (JPIC_SMT)

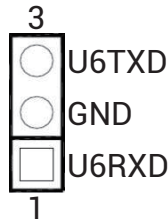

Power Switch (JPWR_SW)

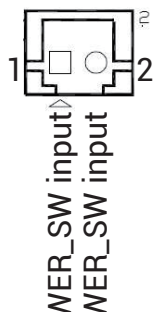

Reset (JEXP_RST)

JEXP_RST	Setting		
	EXP_RST	Default high	Active low
GND			

Motherboard Power Good Rest (JMB_PGD)

JMB_PGD	Setting		
	MB_PWRGD	Default high	Active low
GND			

Boot loader mode (SW1)

SW1	Setting		
	GND		
Boot loader SW	Default high	Active low	

PIC Reset (SW2)

SW2	Setting		
	GND		
MCLR	Default high	Active low	

3.7.3 LED Indicator

SAS HD Link Status (LED_CN4, LED_CN6, LED_CN7)	Green (On)	Link up.
	Blue (Blinking)	Activity detected.
	Off	Link down.
Expander Blink (LED2)	Blue (Blinking)	Expander alive, 0.833Hz (12 seconds per cycle).
MCU Status (LED3)	Yellow (On)	MCU alive.
	Yellow (Off)	Boot loader mode.

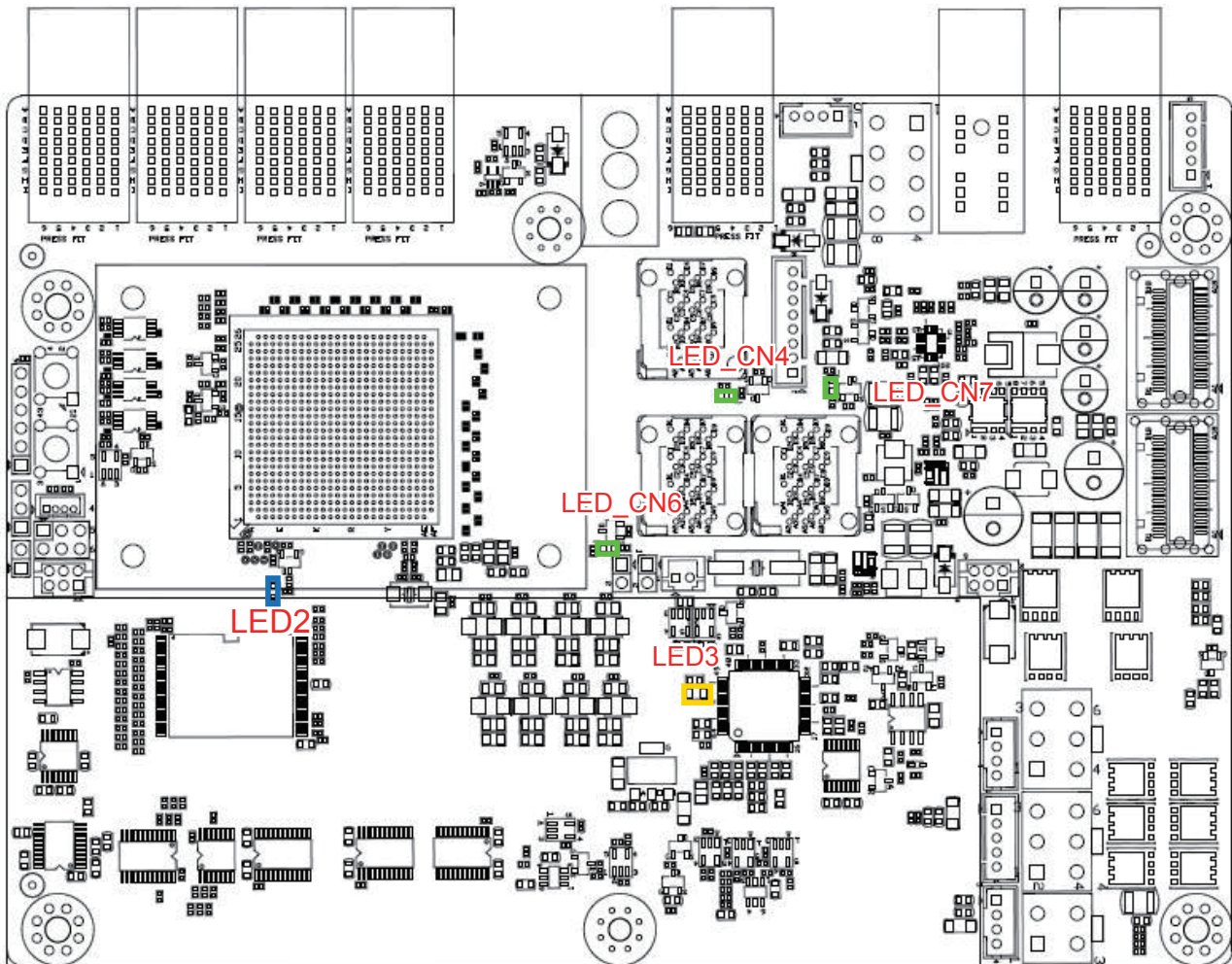

3.8 Riser Card

3.8.1 Placement

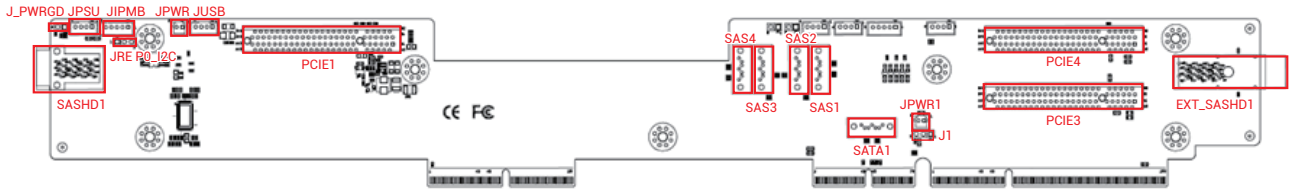

3.8.2 Connector and Jumper

Node Power good connector (J_PWRGD)

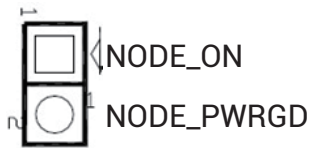

Repeater Program function (JREP_I2C)



PSU Control Input- JPSU

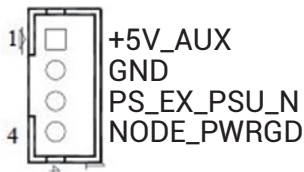

5V_AUX Power (JPWR1)



IPMB connector (JIPMB)

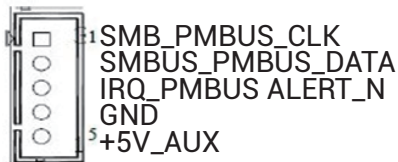

SATA DOM Power Jumper (J1)

J20, J43	Setting	
Pin1-2	SATA	Default
Pin2-3	SATA DOM	

Power switch (JPWR)



NOTE



- If the SATA DOM is supplied to the motherboard, set the jumper to pins 2-3.
- If the SATA DOM is supplied by the external power, set the jumper to pins 1-2.
- If a SATA type hard drive is connected to the motherboard, please ensure that the jumper is closed and set to pins 1-2 (Default setting) to reduce the risk of hard disk damage.

PIC USB connector (JUSB)

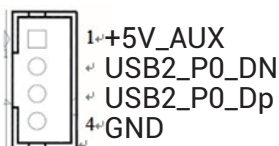

NOTE



When the SATA DOM jumper is set, power will be delivered to the 7th pin of SATA1 connector.

3.8.3 LED Indicator

HDD Access (HDD_ACT_LED)	Green (Blinking)	HDD Activity
Riser IO Activity (ACT_LED)	Green (Blinking)	IO Activity
Status (STS_LED)	Green (On)	PCIE Status
Power LED (PWR_LED)	Green (On)	Power On LED
Motherboard ID LED (ID_LED)	Green (On)	ID LED

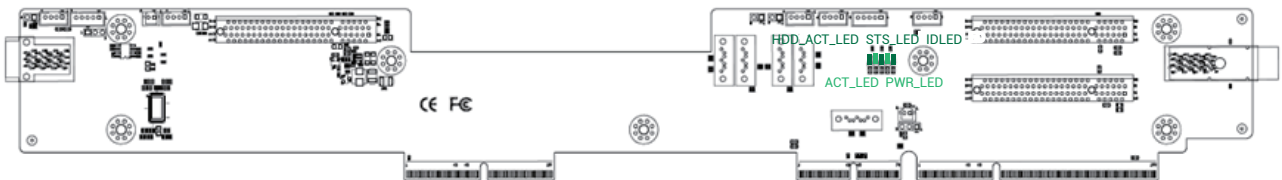

Chapter 4. BIOS Configuration Settings

This chapter demonstrates how to configure the UEFI BIOS settings in your system device. You can enter the BIOS screen during system startup.

To enter BIOS configuration settings,

- Press **Esc** key during the Power-On-Self-Test (POST)

To enter BIOS after POST, you have to restart the system by using one of the three methods:

- Press **Ctrl + Alt + Delete**.
- Press the reset button on the system chassis.
- Turn the system off and on.

NOTE



The following pages provide the details of BIOS menu. Please be noticed that the BIOS menu are continually changing due to the BIOS updating. The BIOS menu provided are the most updated ones when this manual is written.

4.1 Navigation Keys

The navigation keys are listed below.

Function Key	Description
< ↑ > < ← > < → > < ↓ >	Select item.
< Enter >	Select and enter sub-screen.
< + > < - >	Modify selected option.
< F1 >	General help.
< F2 >	Previous Value.
< F3 >	Optimized defaults.
< F4 >	Save & Exit.
< F5 > < F6 >	Change values.
< F7 >	Discard Change and Exit.
< F9 >	Load Optimal Default for all values.
< F10 >	Save changes and exit.
< F12 >	Print Screen.
< Esc >	Exit the current menu screen.

4.2 BIOS Setup

4.2.1 Menu

Press **←** and **→** to select the options of the menu bar.

Press **Enter** to access the option screen.

Menu	Description
Main	Displays basic system information and date & time.
Advanced	Allows configuration of advanced system settings.
Security	Sets passwords and security functions.
Power	Sets the power management parameters.
Boot	Sets boot options, such as Quick Boot or USB Boot.

4.2.2 Startup

Step 1 Press **ESC** to run the BIOS setup procedure.



NOTE

When Quiet Boot is enabled, OEM logo will be displayed instead of post messages.

```

InsydeH20 Version : VIRGV010
BIOS Build Date : 02/21/2017
Processor Type : Intel(R) Xeon(R) Gold 6130 CPU @ 2.10GHz
Processor Type :
System Memory Speed : 2133 MHz

CPUID : 50654
Press Esc for boot options

```

Step 2 There will be a message “Entering SETUP” displayed on the diagnostics screen.

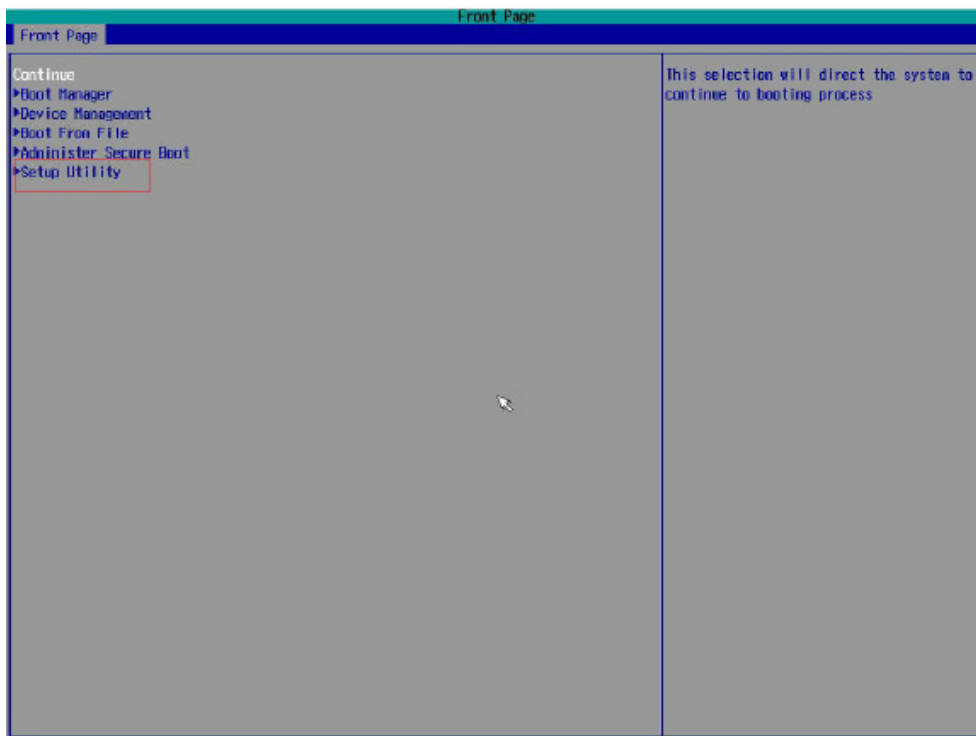

Step 3 Identify the BIOS version.



NOTE

For the official released version, the last digit of the BIOS version must end in a “0.”

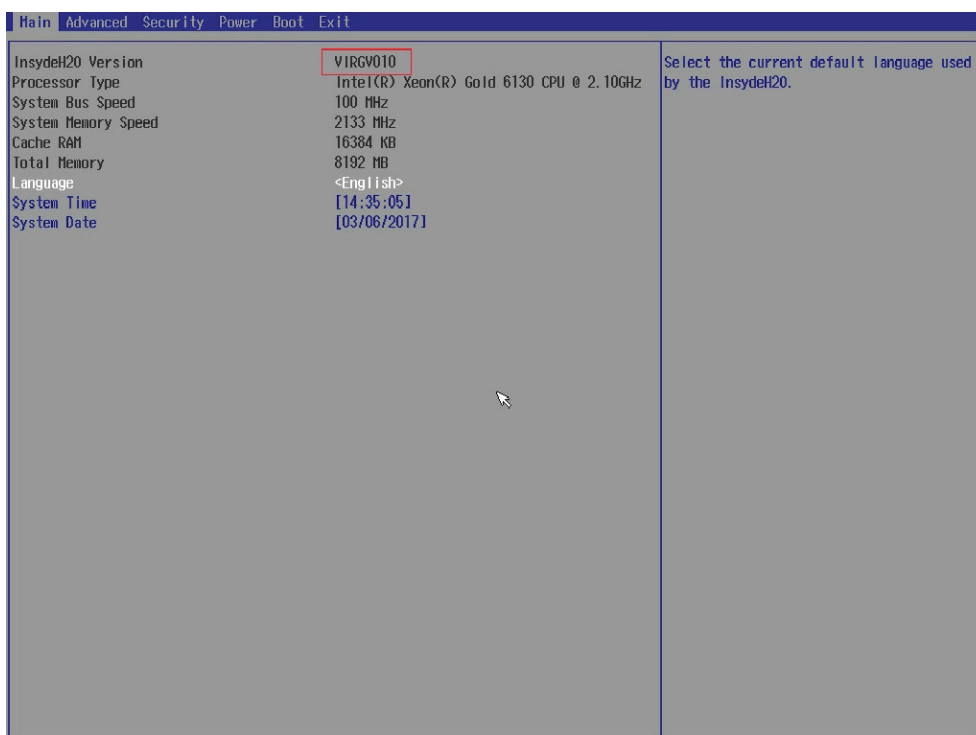

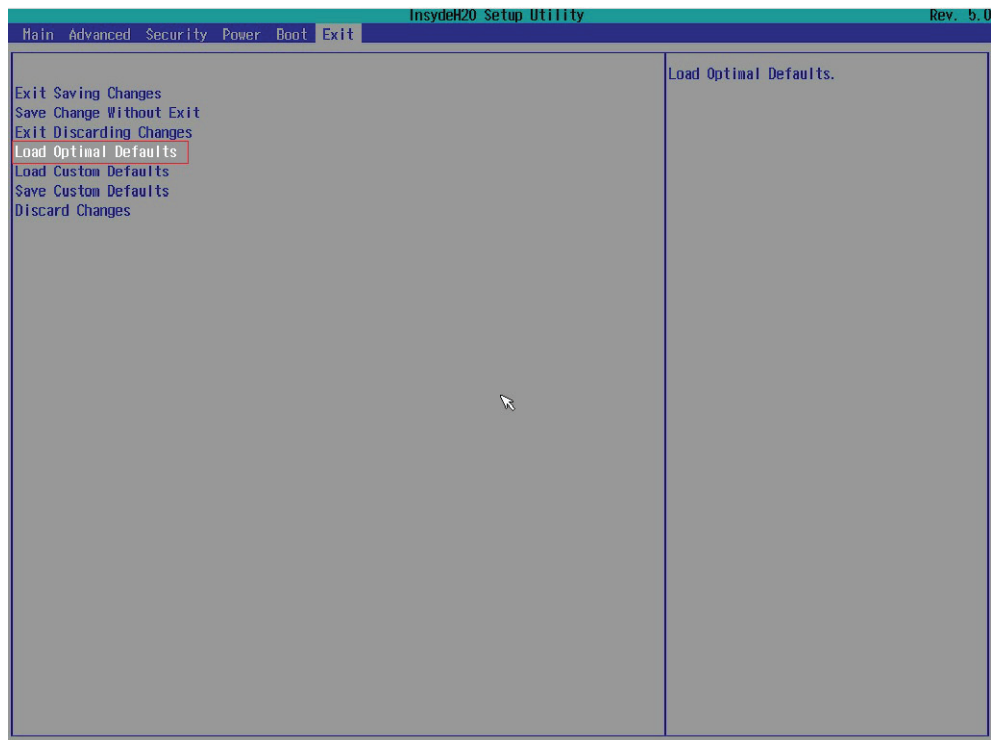
Step 4 Load Optimal Default Setting.**Step 5** Save the setting and exit the BIOS setup utility.

4.3 Main

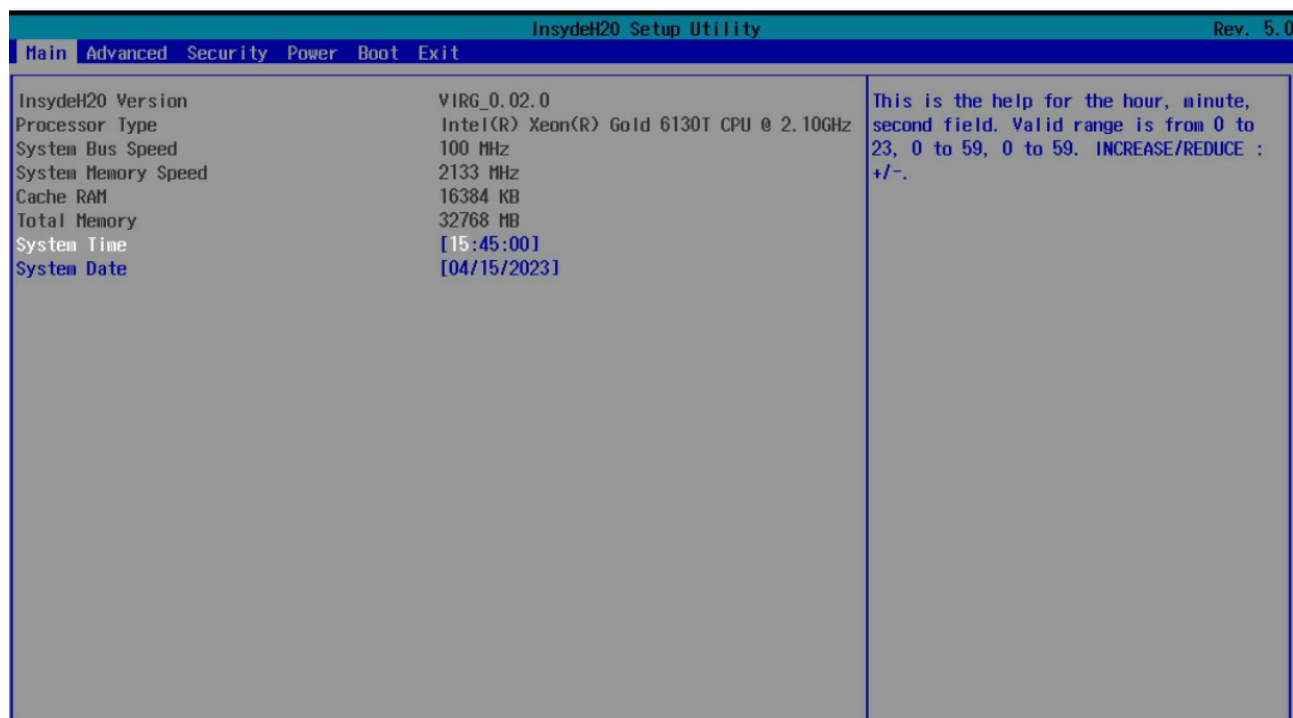

Main Option Key:

4.3.1 Main

Option Key	Description
System time	Configures the current time.
System date	Configures the current date.

4.4 Advanced

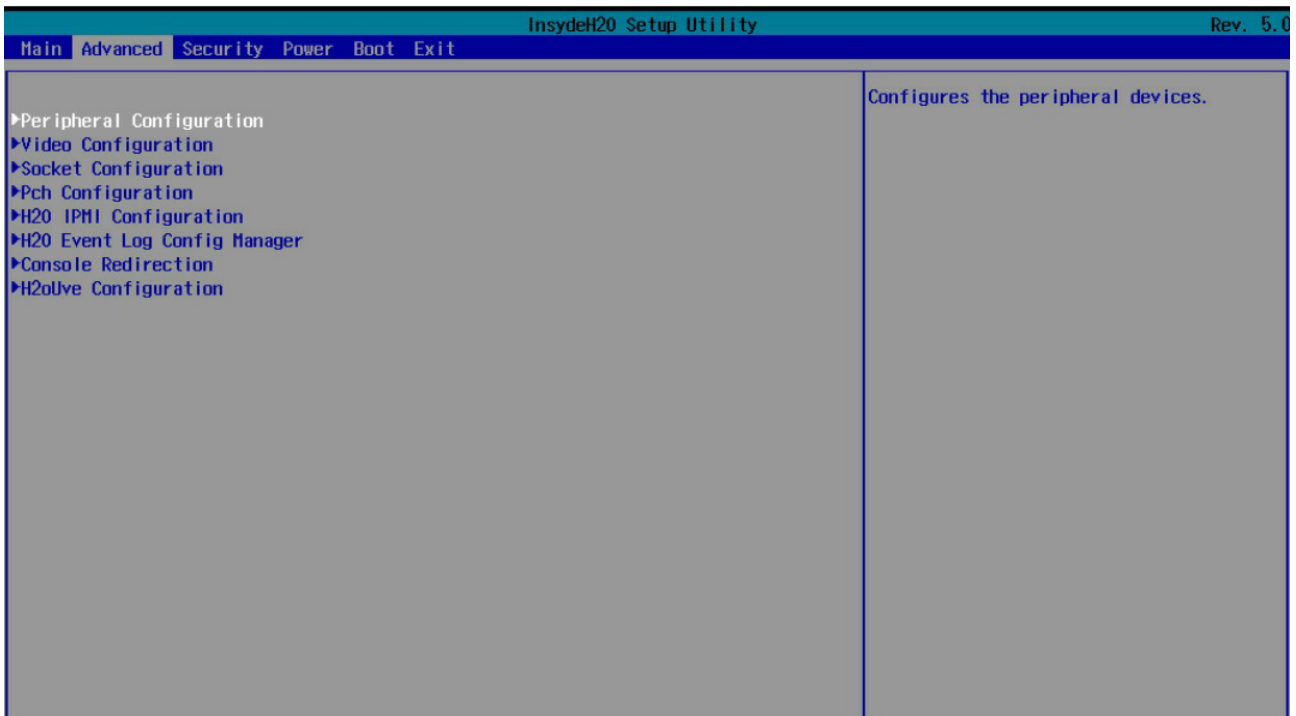

Advanced Option Key:

4.4.1 Peripheral Configuration

Peripheral Configuration		
PCIe SR-IOV	Enable	Disable
PCIe ARI	Enable	Disable
ARI Forward	Enable	Disable
Spread Spectrum	Enable	Disable
Redfish On/Off	Enable	Disable

4.4.2 Video Configuration

Video Configuration		
Display Mode	Plug In First	On Board First

4.4.3 Socket Configuration

Socket Configuration			
Processor Configuration	Hyper-Threading [ALL]	Enable	Disable
	VMX	Enable	Disable
	Enable SMX	Enable	Disable

Processor Configuration	MSR Lock Control	Enable		Disable	
	Extended APIC	Enable		Disable	
Common RefCode Configuration	MMCFG Size	64M	128M	256M	
		512M	1G	2G	
	MMIO High Base	56T	40T	24T	
		16T	4T	1T	
	MMIO High Granularity Size	1G	4G	16G	
		64G	256G	1024G	
	Serial Debug Message Level	Disable		Minimum	
Normal		Maximum			
UPI Configuration	UPI Status	Link Speed Mode	Slow	Fast	
		Link Frequency Select	9.6Gb/s	10.4Gb/s	
			Auto	Use Per Link Setting	
		Link L0p Enable	Auto		
			Enable		
			Disable		
		Link L1 Enable	Auto		
			Enable		
			Disable		
		Legacy VGA Socket	Min=0, Max=3		
Legacy VGA Stack	Min=0, Max=6				
Memory Configuration	Enforce POR	Auto	POR	Disable	
	Memory Frequency	Selections in MHz			
	IMC BCLK	Auto	100 MHz	133 MHz	
	MRC Promote Warnings	Enable		Disable	
	Promote Warnings	Enable		Disable	
	Halt on mem Training Error	Enable		Disable	
	Write Preamble TCLK	Auto	1TCLK	2TCLK	
	Read Preamble TCLK	Auto	1TCLK	2TCLK	
	Enable ADR	Enable		Disable	
	Legacy ADR Mode	Enable		Disable	
	ADR Data Save Mode	Disable	Batterybacked DIMMs	NVDIMMs	
	Check PCH_PM_STS	Enable		Disable	

Memory Configuration	Check Platform Detect ADR	Enable	Disable		
	Erase-Arm NVDIMMs	Enable	Disable		
	Restore NVDIMMs	Enable	Disable		
	Interleave NVDIMMs	Enable	Disable		
	Custom Refresh Rate	Min=0, Max=40			
	SMB Clock Frequency	Auto	100 KHz		
400 KHz		1 MHz			
I/O Configuration	PCI 64-Bit Resource Allocation	Enable	Disable		
	PCIe Train by BIOS	No	Yes		
	PCIe Hot Plug	Auto	Manual		
		Enable	Disable		
	PCIe ACPI Hot Plug	Enable	Disable	Per-Port	
	MC BaseAddress Range	Auto	Below 4G		
	MC Index Position	12	20		
	MC Num Group	1	8	32	64
	PCI-E Completion Timeout (Global) Disable	No	Yes	Per-Port	
		Program the Completion Timeout Value (D:x F:0 O:B8h B:3-0) where x is 0-3			
PCI-E ASPM Support (Global)	L1 Only	Disable	Per-Port		
Advanced Power Configuration	CPU State Control	WFR Uncore GV Rate Reduction	Auto		
			Enable		
			Disable		
		Uncore Freq Scaling (UFS)	Enable	Disable	
		SpeedStep (Pstates)	Enable	Disable	
		Config TDP	Nominal		
			Level 1		
			Level 2		
		P State Domain	All	One	
		EIST PSD Function	HW_ALL		
SW_ALL					
SW_ANY					
SINGLE_PCTL	Enable	Disable			

Advanced Power Management Configuration	CPU P State Control	Single Power Domain (SPD)	Enable	Disable
		Boot performance mode	Max Performance	
			Max Efficient	
			Set by Intel Node Manager	
		Energy Efficient Turbo	Enable	Disable
		Turbo Mode	Enable	Disable
	CPU Flex Ratio Override	Enable	Disable	
	Hardware PM State Control	Hardware P-States	Disable	Native Mode
			Out of Band Mode	Native Mode with No Legacy Support
		HardwarePM Interrupt	Enable	Disable
		EPP Enable	Enable	Disable
		EPP profile	Performance	Balanced Performance
			Balanced Power	Power
		APS rocketing	Enable	Disable
		Scalability	Enable	Disable
		PPO-Budget	Enable	Disable
	Package C State Control	Package C State	C0/C1 state, state	C2 state
			C6(non Retention)	C6(Retention) state
			No Limit	Auto
		C2C3TT	Min=0, Max=255	
		PKG C-state Lat. Neg.	Enable	Disable
	LTR IIO Input	Take IIO LTR input.	Ignore IIO LTR input.	

4.4.4 PCH Configuration

PCH Configuration				
PCH Devices	PCH state after G3	S0	S5	Last State
PCH SATA Configuration	SATA Controller			
	Configure SATA as	AHCI		RAID
	Support Aggressive Link Power Management	Enable		Disable
	Alternate Device ID on RAID	Enable		Disable
	Load EFI Driver for RAID	Enable		Disable
	Port 0	Enable		Disable
	SATA Port 0 DevSlp	Enable		Disable
	Hot Plug	Enable		Disable
	Configure as eSATA	Enable		Disable
	Mechanical Presence Switch	Enable		Disable
	Spin Up Device	Enable		Disable
	SATA Device Type	Hard Disk Drive		Sata State Drive
	SATA Topology	Unknown	ISATA	Direct Connect
		Flex		M.2
	Port 1	Enable		Disable
	SATA Port 1 DevSlp	Enable		Disable
	Hot Plug	Enable		Disable
	Configure as eSATA	Enable		Disable
	SATA HDD Unlock	Enable		Disable
	SATA Led locate	Enable		Disable
	RAID 0	Enable		Disable
	RAID 1	Enable		Disable
	RAID 10	Enable		Disable
	RAID 5	Enable		Disable
	Intel Rapid Recovery Technology	Enable		Disable
	RAID Option ROM UI banner	Enable		Disable
IRRT Only on ESATA	Enable		Disable	

PCH SATA Configuration	Smart Response Technology	Enable	Disable	
	RAID OROM prompt delay	2 Seconds	4 Seconds	
		6 Seconds	8 Seconds	
PCH sSATA Configuration	sSATA Controller	Enable	Disable	
	Configure sSATA as	AHCI	RAID	
	Support Aggressive Link Power Management	Enable	Disable	
	Alternate Device ID on RAID	Enable	Disable	
	Load EFI Driver for RAID	Enable	Disable	
	Port 0	Enable	Disable	
	Hot Plug	Enable	Disable	
	Configure as eSATA	Enable	Disable	
	Spin Up Device	Enable	Disable	
	sSATA Device Type	Hard Disk Drive	Sata State Drive	
	SATA Topology	Unknown	ISATA	Direct Connect
		Flex		M.2
	Port 1	Enable	Disable	
	Hot Plug	Enable	Disable	
	Configure as eSATA	Enable	Disable	
	SATA HDD Unlock	Enable	Disable	
	SATA Led locate	Enable	Disable	
	RAID 0	Enable	Disable	
	RAID 1	Enable	Disable	
	RAID 10	Enable	Disable	
	RAID 5	Enable	Disable	
	Intel Rapid Recovery Technology	Enable	Disable	
	RAID Option ROM UI banner	Enable	Disable	
	IRRT Only on ESATA	Enable	Disable	
	Smart Response Technology	Enable	Disable	
	RAID OROM prompt delay	2 Seconds	4 Seconds	
		6 Seconds	8 Seconds	
	PCH Internal LAN	Enable	Disable	
	Wake on LAN	Enable	Disable	

PCH sSATA Configuration	SLP_LAN# Low on DC Power	Enable		Disable	
	K1 off	Enable		Disable	
	FPK Port 1-4	Enable	Management	Disable	
	PCI Delay Optimization	Enable		Disable	
	Compliance Test Mode	Enable		Disable	
	PCI-E ASPM Support (Global)	Per individual port		L1 Only	
	CTO for Uplink x16 CTO for Uplink x8	40-50ms(spec 50us-50ms)	40-50ms(spec 16ms-55ms)	160-170ms (spec 65ms-210ms)	
		400-500ms (spec 260ms-900ms)	1.6-1.7s(spec 1s-3.5s)	Disable	
	MPL for Uplink x16 MPL for Uplink x8	MPL 128B	MPL 256B	MPL 512B	
	PCIE Clock Gating	Enable		Disable	
	PCH DMI ASPM	Platform-POR	ASPM L	Disable	
	DMI Link Extended Synch Control	Enable		Disable	
	Stop and Scream	Enable		Disable	
	Expanded SPI TPM Transaction Length Enable	Enable		Disable	
	Subtractive Decode	Enable		Disable	
	Subtractive Decode Port#	Min=0, Max=7			
	PCIe Root Port Function Swapping	Enable		Disable	
	Max Read Request Size	MRRS 128B	MRRS 256B	MRRS 512B	
		MRRS1024B	MRRS2048	MRRS4096	
	PCI Express Root Port 1-20	PCIE ASPM	Disable ASPM		
			ASPM L1		
			ASPM Auto		
		L1 Substates	Disable		L1.1
			L1.2		L1.1 & L1.2
		Gen 3 Eq Phase3 Method	Hardware		
	Static Coeff				
	Software Search				

PCH sSATA Configuration	PCI Express Root Port 1-20	ACS	Enable	Disable
		URR	Enable	Disable
		FER	Enable	Disable
		NFER	Enable	Disable
		CER	Enable	Disable
		SEFE	Enable	Disable
		SENF	Enable	Disable
		SECE	Enable	Disable
		PME SCI	Enable	Disable
		Hot Plug	Enable	Disable
		Advanced Error Reporting	Enable	Disable
		PCIe Speed	Auto	Gen 1
			Gen 2	Gen 3
		MSI	Enable	Disable
		PCIe Lane Topology	Unknown	x1
	x4		Sata Express	
	M.2			
	Max Payload Size	MPL		
		MPL 128B		
		MPL 256B		
	Compl. Timeout	40-50ms(spec 50us-50ms)	40-50ms (spec 16ms-55ms)	
		160-170ms (spec 65ms-210ms)	400-500ms (spec 260ms-900ms)	
		1.6-1.7s(spec 1s-3.5s)	Disable	
	PCH PCIe LTR Configuration	PCH PCIe1 LTR	Enable	Disable
		Snoop Latency Override	Auto	
			Manual	
			Disable	
		Snoop Latency Value	Min=0, Max=1023	
Snoop Latency Multiplier		1 ns	32 ns	
	1024 ns	32768 ns		
	1048576 ns	33554432 ns		

PCH sSATA Configuration	PCH PCIe LTR Configuration	Non Snoop Latency Override	Auto	
			Manual	
			Disable	
		Non Snoop Latency Value	Min=0, Max=102	
		Non Snoop Latency Multiplier	1 ns	32 ns
			1024 ns	32768 ns
1048576 ns	33554432 ns			
PCIE1 LTR Lock	Enable	Disable		

4.4.5 H2o IPMI Configuration

H2o IPMI Configuration				
IPMI Support	Enable	Disable		
BMC Warmup Time	Min=0, Max=240			
ACPI SPMI Table	Enable	Disable		
Boot Option Support	Enable	Disable		
Set BIOS version to BMC	Enable	Disable		
BMC Configuration	Watchdog Timer Support	Enable	Disable	
	Not disable in OS	Enable	Disable	
	Watchdog Timer Timeout	Min=2, Max=8		
	Watchdog Timer Action	No Action	Hard Reset	
		Power Down	Power Cycle	
	Power Cycle Time Support	Enable	Disable	
	Power Cycle Time	Min=0, Max=255		
	Power Button	Enable	Disable	
	Reset Button	Enable	Disable	
	NMI Button	Enable	Disable	
	LAN Channel Number	Min=0, Max=15		
	IPv4 Source	Static	DHCP	
	IPv6 Mode	Enable	Disable	
IPv6 Prefix Length	Min=0, Max=15			
SDR List	SDR List Support	Enable	Disable	

4.4.6 H2o Event Log Config Manager

H2o Event Log Config Manager				
Configurations Page	Console Serial Redirect	Enable		Disable
	Terminal Type	VT_100		VT_100+
		VT_UTF8		PC_ANSI
	Baud Rate	1200		2400
		4800		9600
		19200		38400
		57600		115200
	Data Bits	7 Bits		8 Bits
	Parity	None	Even	Odd
	Stop Bits	1 Bits		2 Bits
	Flow Control	None	RTS/CTS	XON/XOFF
	Information Wait Time	0 Second	2 Seconds	5 Seconds
		10 Seconds		30 Seconds
	C.R. After Legacy Boot	No		Yes
	Text Mode Resolution	AUTO		Force 80x25,Force 80x24 (DEL FIRST ROW)
		Force 80x24 (DEL LAST ROW)		Limit 128x40
Auto Refresh	Enable		Disable	
Auto adjust Terminal resolution	Enable		Disable	

4.5 Security

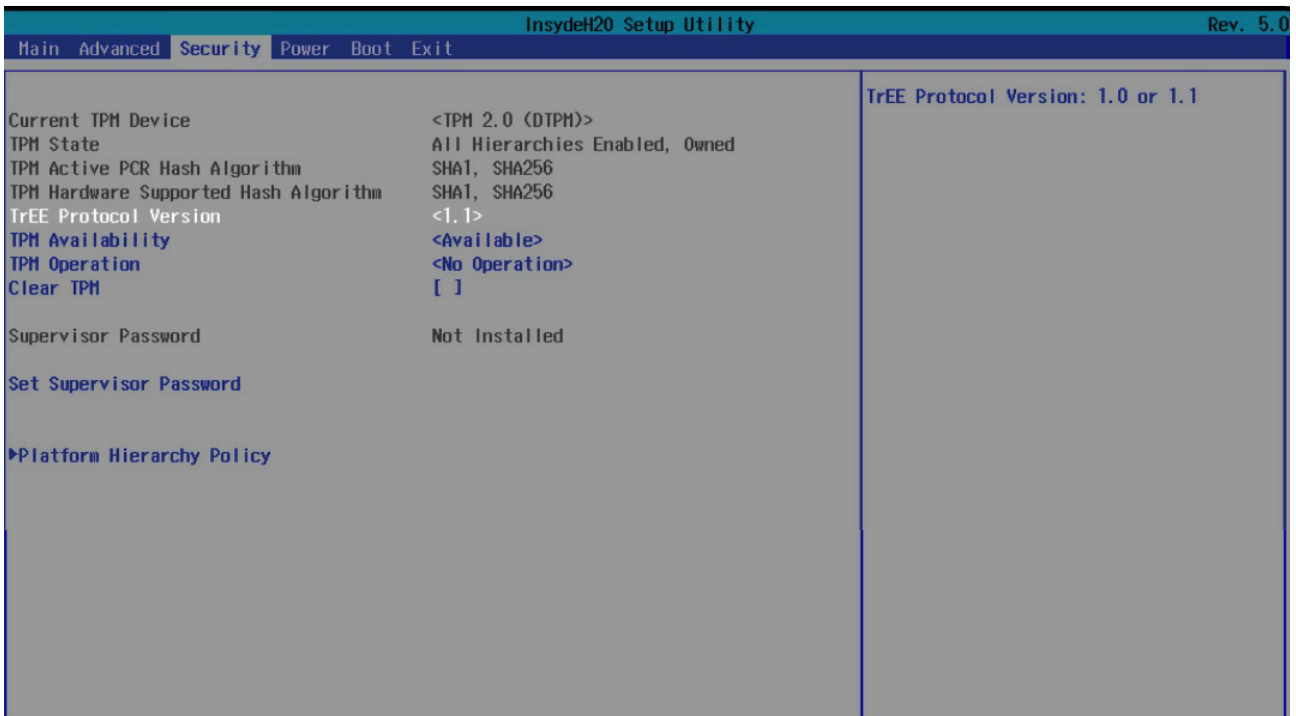

Security Option Key:

4.5.1 Security

Security			
Current TPM Device	Not Detected	TPM 1.2	TPM 2.0
TrEE Protocol Version	1.0	1.1	
TPM Availability	Available	Hidden	
TPM Operation	No operation	Disable and Deactivate	Enable and Activate

4.6 Power

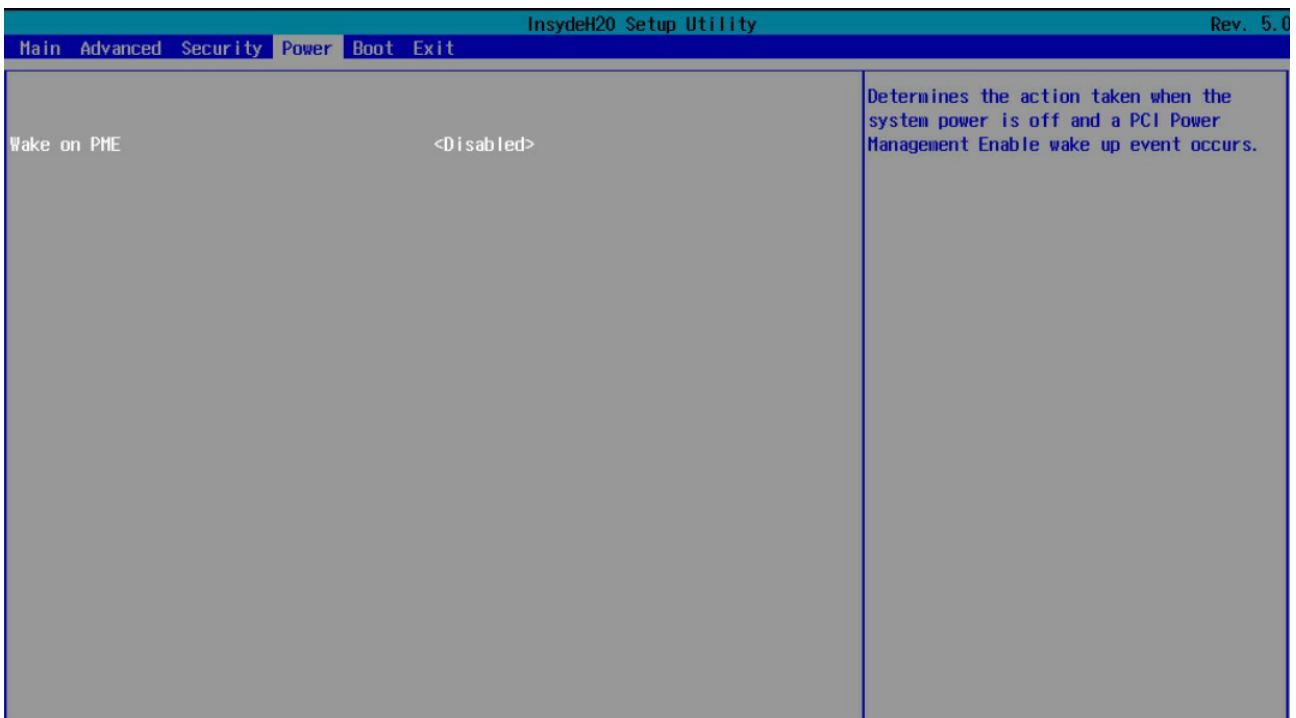

Power Option Key:

4.6.1 Power

Power		
Wake on PME	Enable	Disable

4.7 Boot

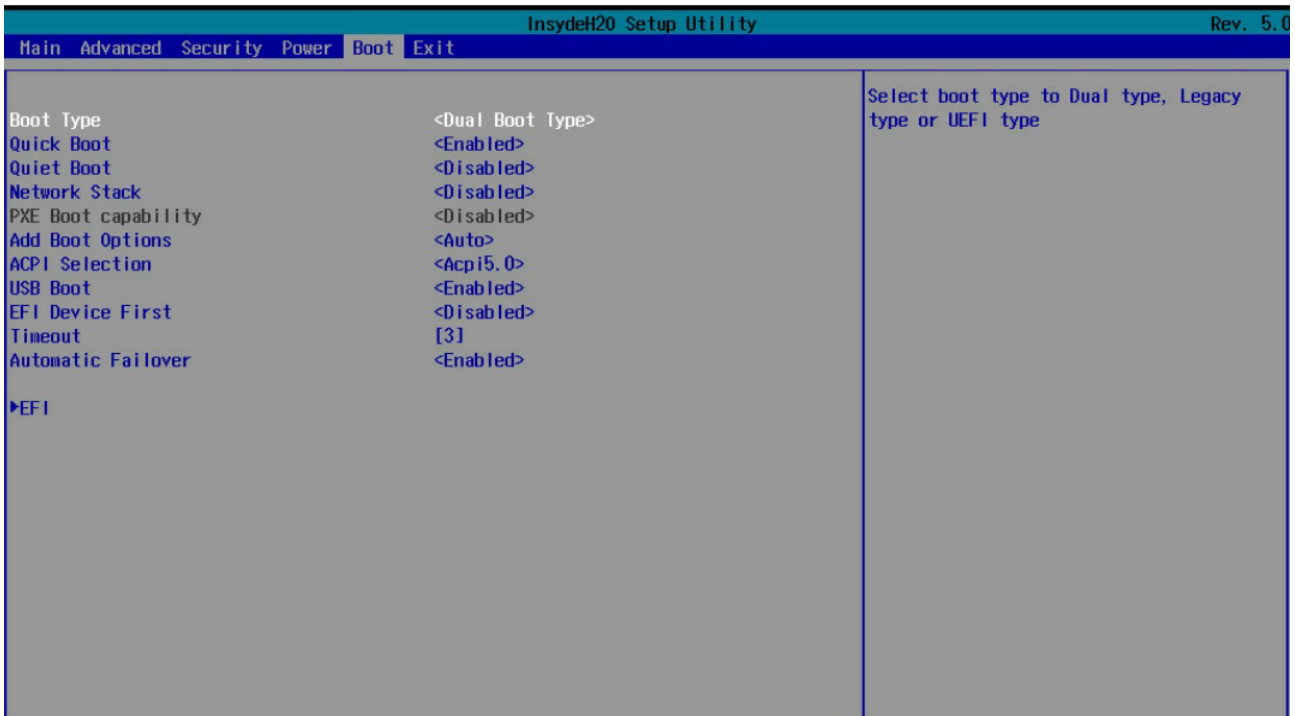

Boot Option Key:

4.7.1 Boot

Boot			
Boot Type	Dual Boot Type	Legacy Boot Type	UEFI Boot Type
Quick Boot	Enable	Disable	
Quiet Boot	Enable	Disable	
Network Stack	Enable	Disable	
PXE Boot to LAN	Enable	Disable	
PXE Boot capability	Disable	UEFI:IPv4	UEFI:IPv6
	UEFI:IPv4/UEFI:IPv6		Legacy
Add Boot Options	First	Last	Auto
ACPI Selection	Acpi1.0B	Acpi3.0	Acpi4.0
	Acpi5.0	Acpi6.0	Acpi6.1
USB Boot	Enable	Disable	
EFI Device First	Enable	Disable	
Timeout	Min=0, Max=10		
Automatic Failover	Enable	Disable	

4.8 Exit

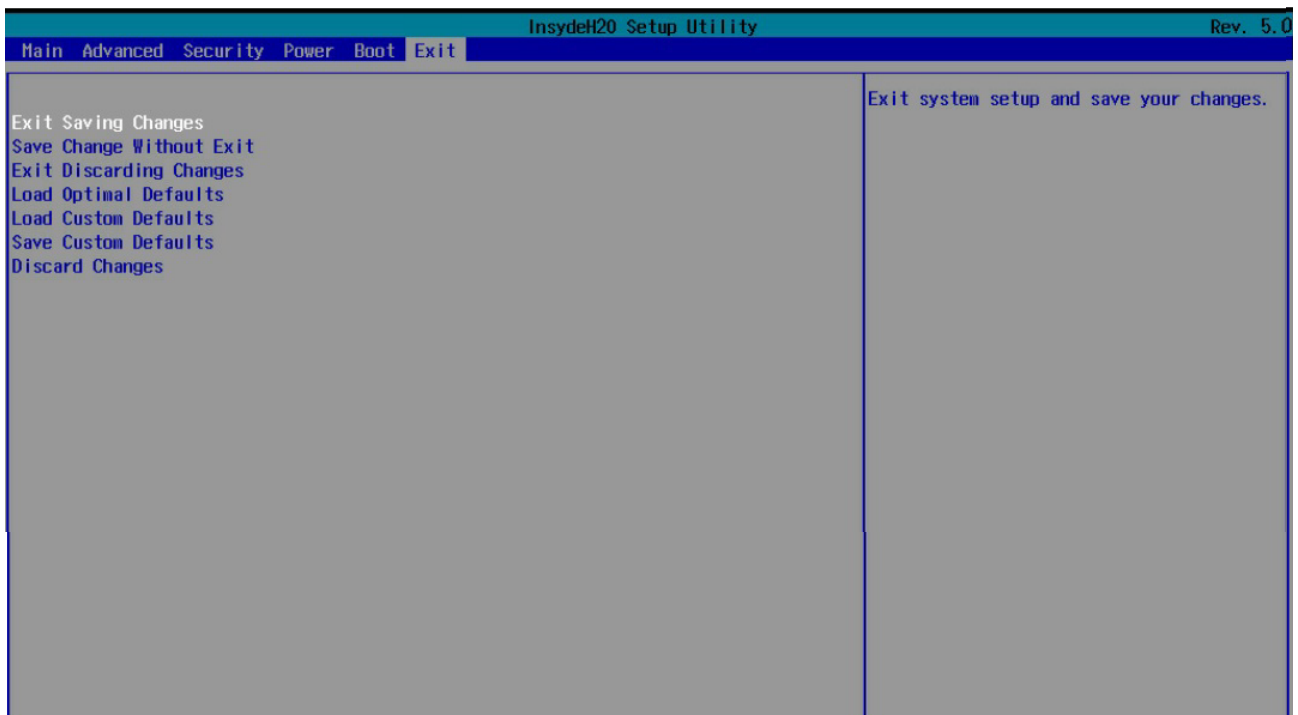

Exit Option Key:

4.8.1 Exit

Save and Exit	
Exit Saving Changes	Exit system setup and save your changes.
Save Change Without Exit	Save your changes without exiting the system.
Exit Discarding Changes	Discard your changes when existing the system.
Load Optimal Defaults	Load optimal default items.
Load Custom Defaults	Resets the BIOS settings to the default values and overwrites any previously customized settings.
Save Custom Defaults	Saves the cumostomized defaults in BIOS settings.
Discard Changes	Discard your changes.

4.9 BIOS Update Process

This is the manual for updating BIOS on **Pavo** system, the new BIOS supports to update from BIOS ver **Pavo1070** or later. Here are the update procedures

DOS:

1. Copy Pavo1080.bin into **dos** folder
2. Copy dos folder to USB stick or HDD
3. Enter to DOS folder and execute the below command flash.bat
4. Reboot if complete the updated

Linux:

1. Copy Pavo1080.bin into [linux/ InsydeH2OFFT_x86_LINUX64_200.02.00.02](#) folder
2. Copy linux folder to USB stick or HDD
3. Enter to linux folder and execute the below command ./flash.sh
4. Reboot if complete the updated

EFI:

1. Copy Pavo1080.bin into **efi** folder
2. Copy efi folder to USB stick or HDD
3. Boot into internal shell enters the usb efi folder and executes the below command Bios.
nsh
4. Reboot if complete the updated



NOTE

Please refer to "Bios Update Process.doc" in bios release zip file for details.

Chapter 5. BMC Configuration Settings

Insert Ethernet LAN cable into the BMC LAN port. There are two methods to setup BMC IP:

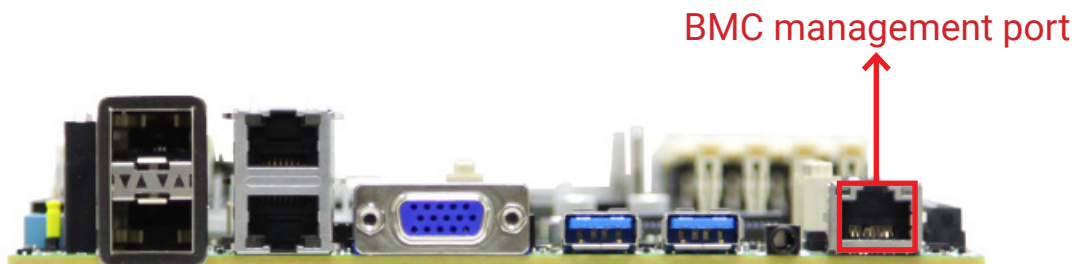

5.1 BIOS Setup

Step 1 BIOS SETUP → Advanced → H2O IPMI configuration → BMC Configuration → IPv4 source → Static

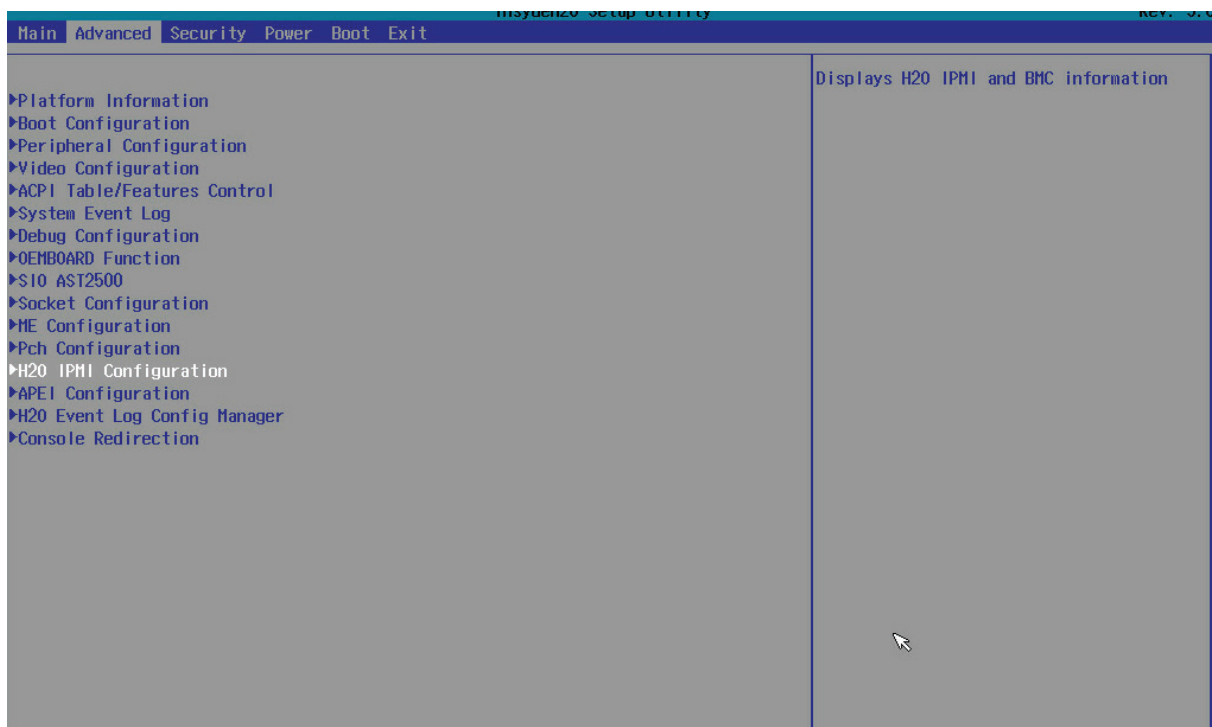

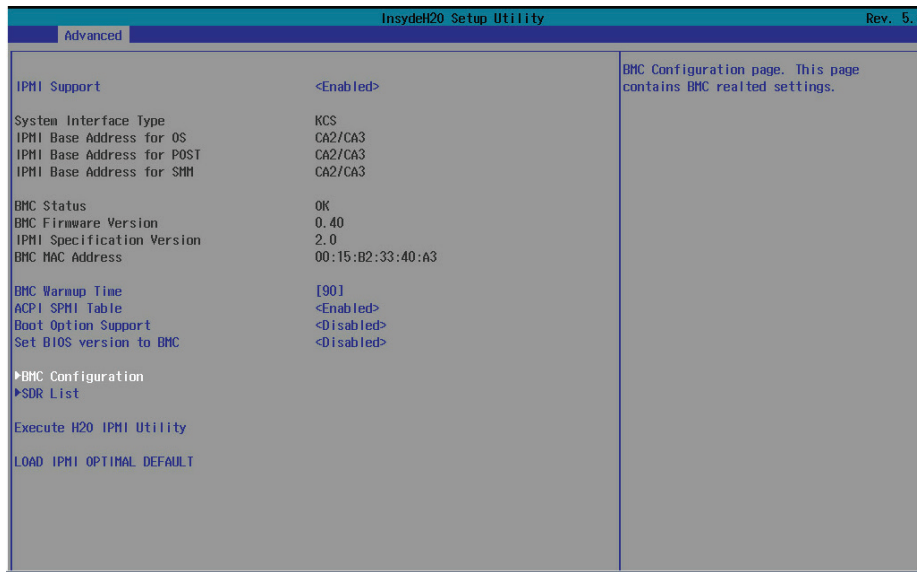

Step 2 Type in the IP address. Configure the static IP address.

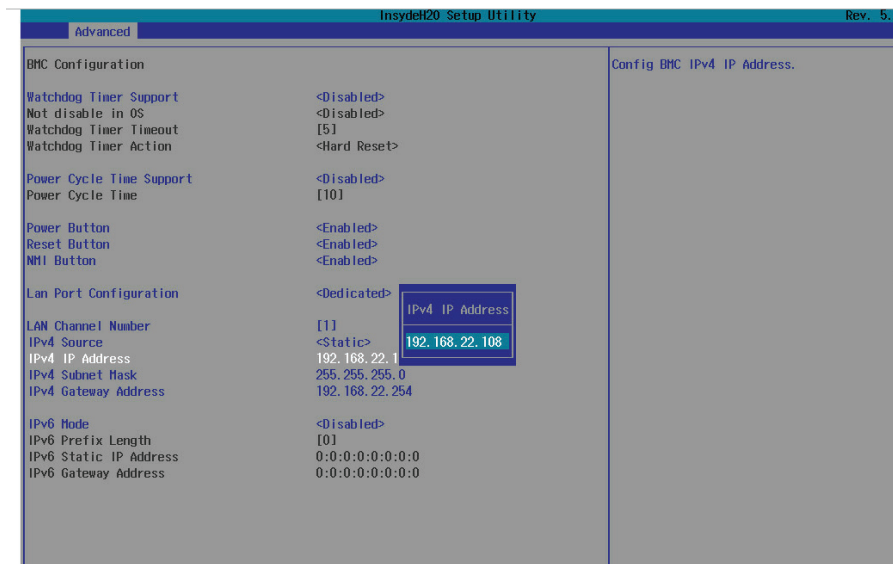

Step 3 Type in the subnet mask address.

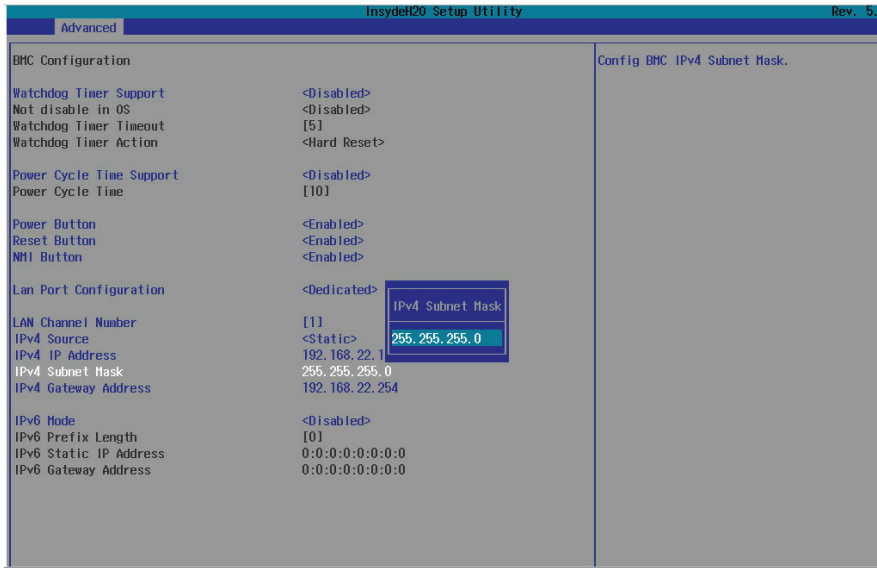

Step 4 Type in the gateway address.

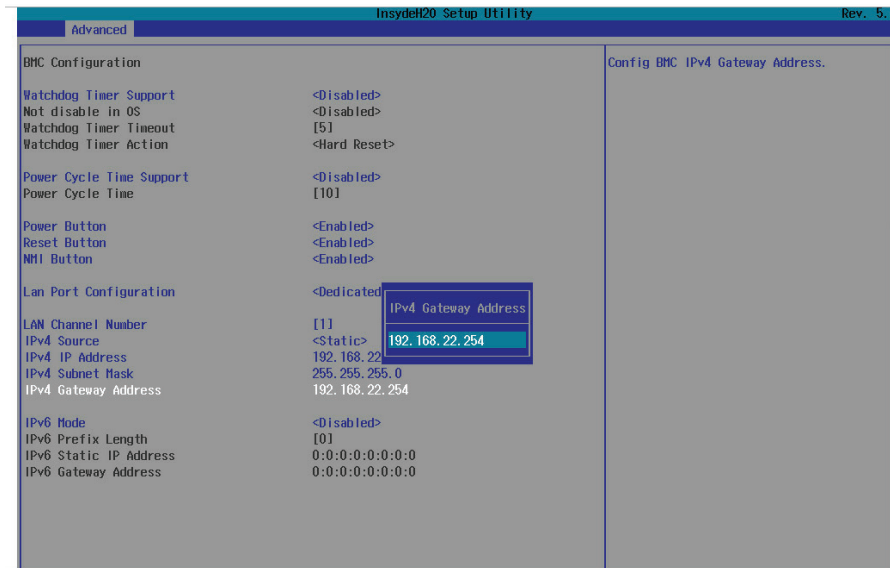

5.2 Login



NOTE

This feature works with JAVA 6 Runtime installed Console Environment

The IP source default is DHCP. You can change the IP source to DHCP or Static by the BIOS utility or the system check.

Step 1 Open the browser then type the BMC IP address.

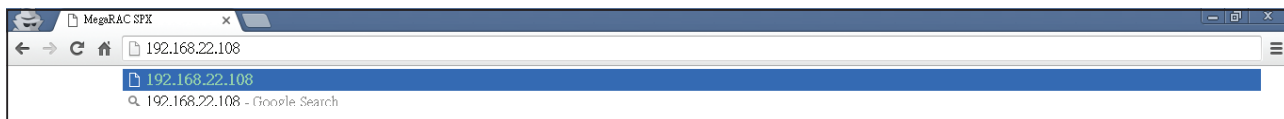

Step 2 Use the default user name and password for first-time BMC WEB GUI login.

Field:	Default
UserName:	admin
Password:	admin

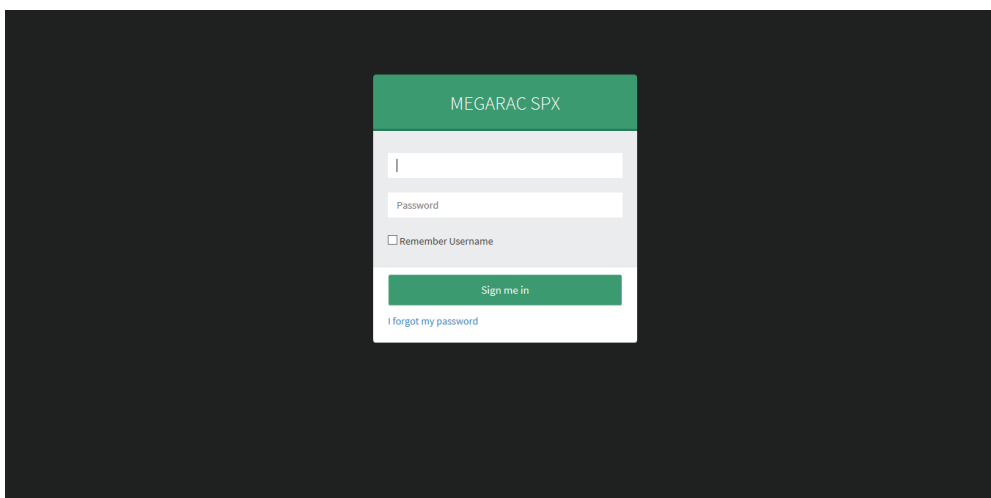

NOTE

The default user name and password are in lower-case characters.



NOTE

Users who login the root user name and password will have full administrative power. The root password can be changed after login.

5.3 Web GUI







5.3.1 Menu Bar

Click to select the options of the menu bar.

Menu	Description
Dashboard	The Dashboard page gives the overall information about the status of a device.
Sensor	The Sensor Readings page displays all the sensor related information.
FRU Information	The FRU Information page displays the details for FRU devices in the system.
Logs and Reports	The Logs and Reports page monitors and reports on the status of IPMI event and video.
Settings	The Settings page allows you to configure various basic settings, such as date & time, KVM Mouse, Services, and ect.
Remote Control	The Remote Control page allows you to remotely manage server hardware components.
Image Redirection	The Image Redirection page is used to configure the image into BMC for redirection.
Power Control	The Power Control page allows you to view and control the power of your server.
Maintenance	This group of pages allows you to do maintenance tasks on the device.
Sign out	The Sign out page allows you to log out of the web GUI.

5.3.2 User Information and Quick Button

The user information and quick access buttons are located at the top right corner. It displays the logged-in user, his/her privilege and the four quick buttons allowing you to perform different functions.

Button		Description
User		Only valid commands are allowed.
Operator		All BMC commands are allowed except for the configuration commands that can change the behavior of the out-of-hand interfaces.
Administrator		All BMC commands are allowed.
No access		Login access denied.
	Notification	Click to view notification messages.
	Warning	Click to view warning messages.
	Sync	Click to synchronize with the latest sensor and event log updates.
	Refresh	Click to reload the current page.
 root ▾	Root-administrator	Sign out: Click to log out of the GUI Profile: Click to enter the User Management Configuration dialog box in figure xx.
	Help	Click to view more details on field descriptions.

5.3.3 Dashboard:

The Dashboard page gives the overall information about the status of a device.

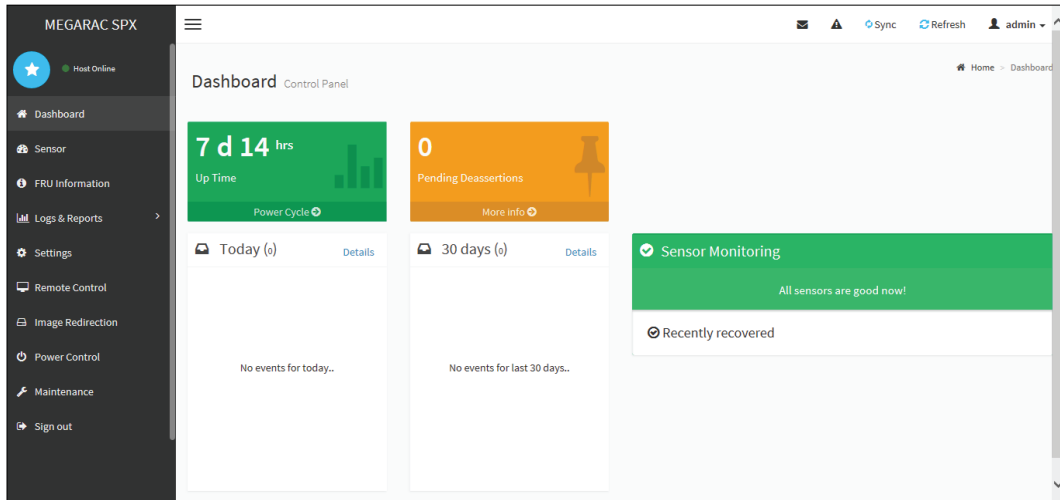

5.3.4 Sensor

The Sensor Readings page displays all the sensor related information.

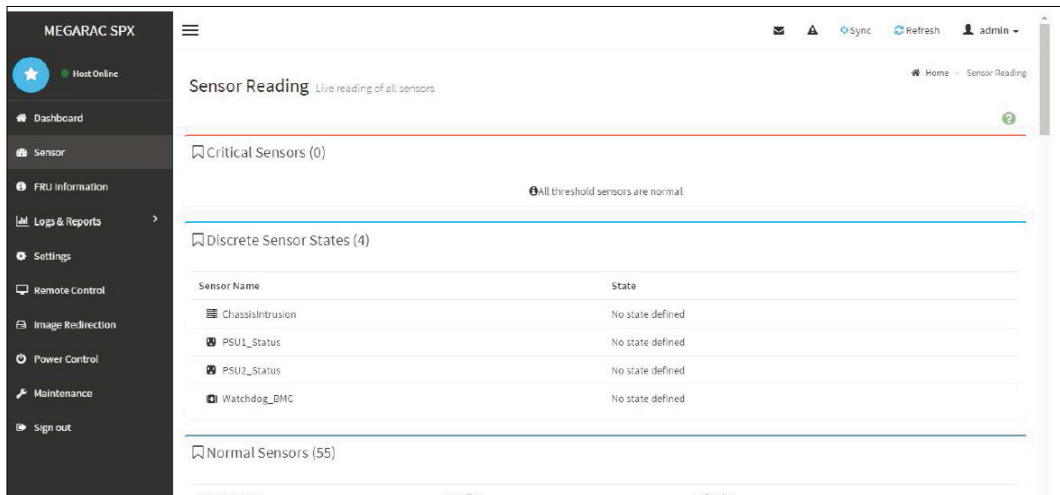

5.3.5 FRU Information

The FRU Information page displays Basic Information, Chassis Information, Board Information and Product Information of the FRU device. Click FRU Information on the menu bar to view the details of the selected device.

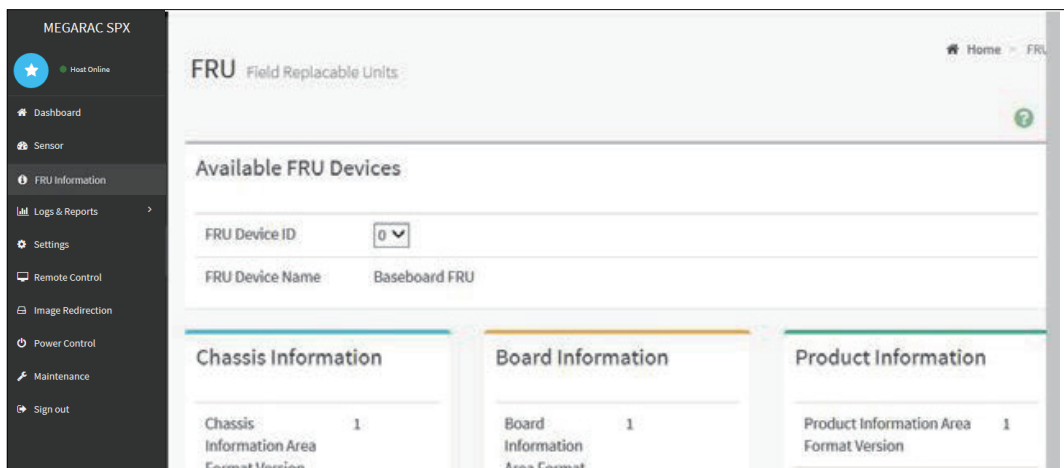

5.3.6 Logs and Report

The System Inventory page displays IPMI Event Log and Video Log. Click **Logs and Reports** from the menu bar.

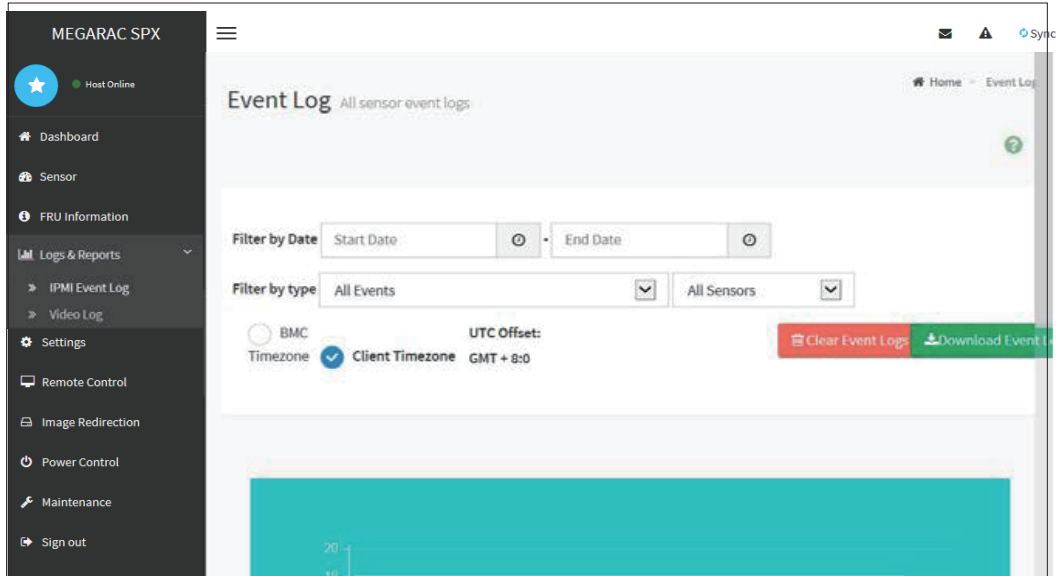

5.3.7 Settings

The Settings page allows you to access various configuration settings.

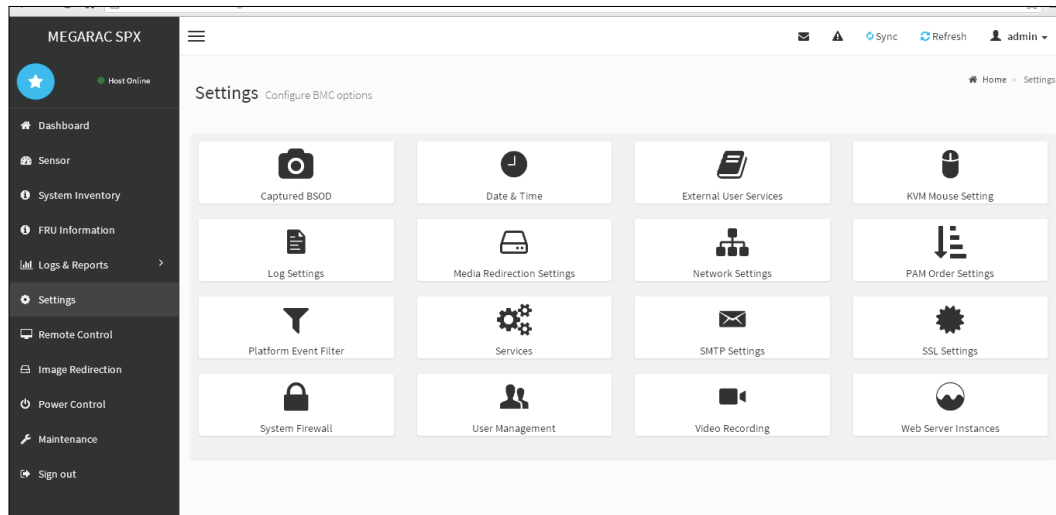

5.3.8 KVM Mouse Setting

The KVM Mouse Setting page allows you to configure the mouse mode to relative, absolute, and other.

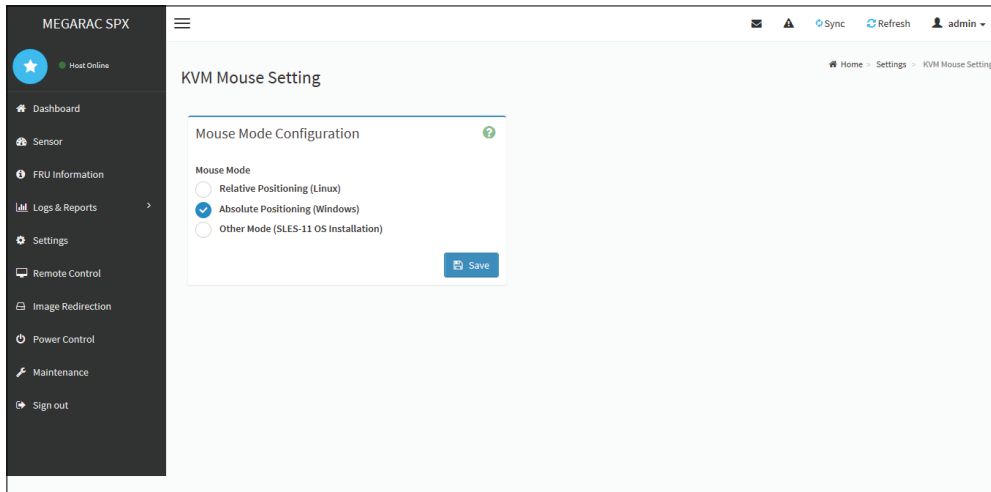

- For Windows OS environment, set mode to absolute.
- For Linux OS environment, set mode to relative.
- For SLES-11 OS environment, set mode to other mode.

Remote Control: The Remote Control page allow you to access any of the managed devices within your system.

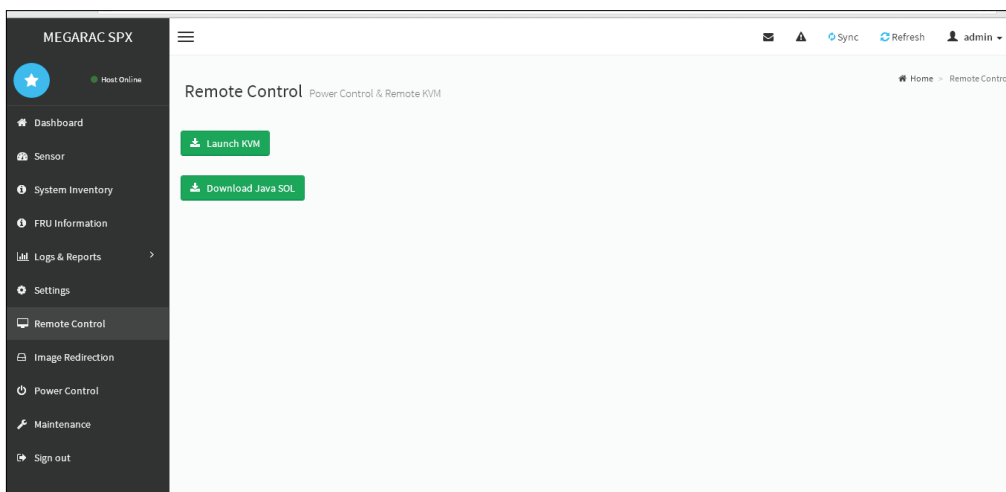

Launch KVM:

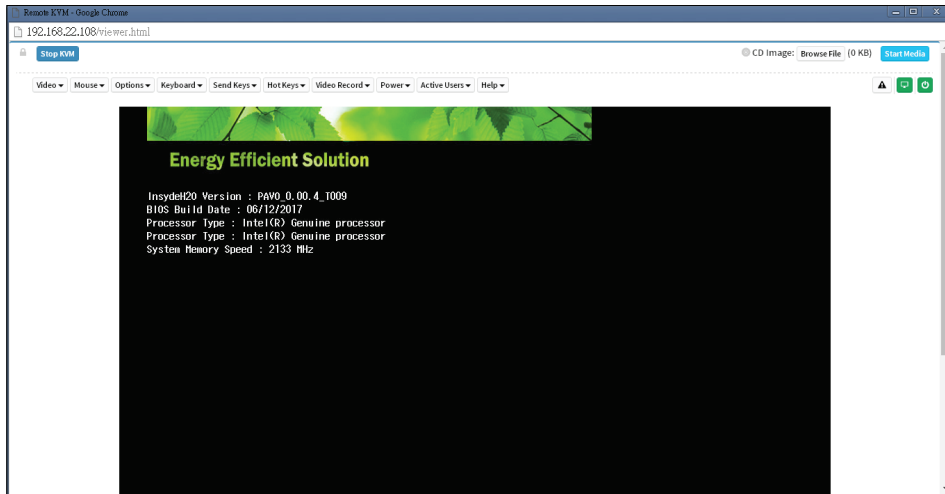

5.3.9 Firmware Update

This wizard takes you through the process of firmware upgradation. A reset of the box will automatically follow if the upgrade is completed or cancelled. An option to Preserve All Configuration is available. Enable it, if you wish to preserve configured settings through the upgrade.

Warning: Please note that after entering update mode widgets, other web pages and services will not work. All open widgets will be closed automatically. If upgrade process is cancelled in the middle of the wizard, the device will be reset.

NOTE

The firmware upgrade process is a crucial operation. Make sure that the chances of a power or connectivity loss are minimal when performing this operation.

Once you enter into Update Mode and choose to cancel the firmware flash operation, the Mega-RAC® card must be reset. This means that you must close the Internet browser and log back onto the MegaRAC® card before you can perform any other types of operations.

Once Firmware upgrade using web is started, the regular IPMI command will not be allowed for safety concern if Enable IPMI Command handling during flashing support is disabled in project configuration.

To configure, choose [Firmware Image Location](#) under Maintenance. To open Firmware Update page, click [Maintenance](#) → [Firmware Update](#) from the menu bar.

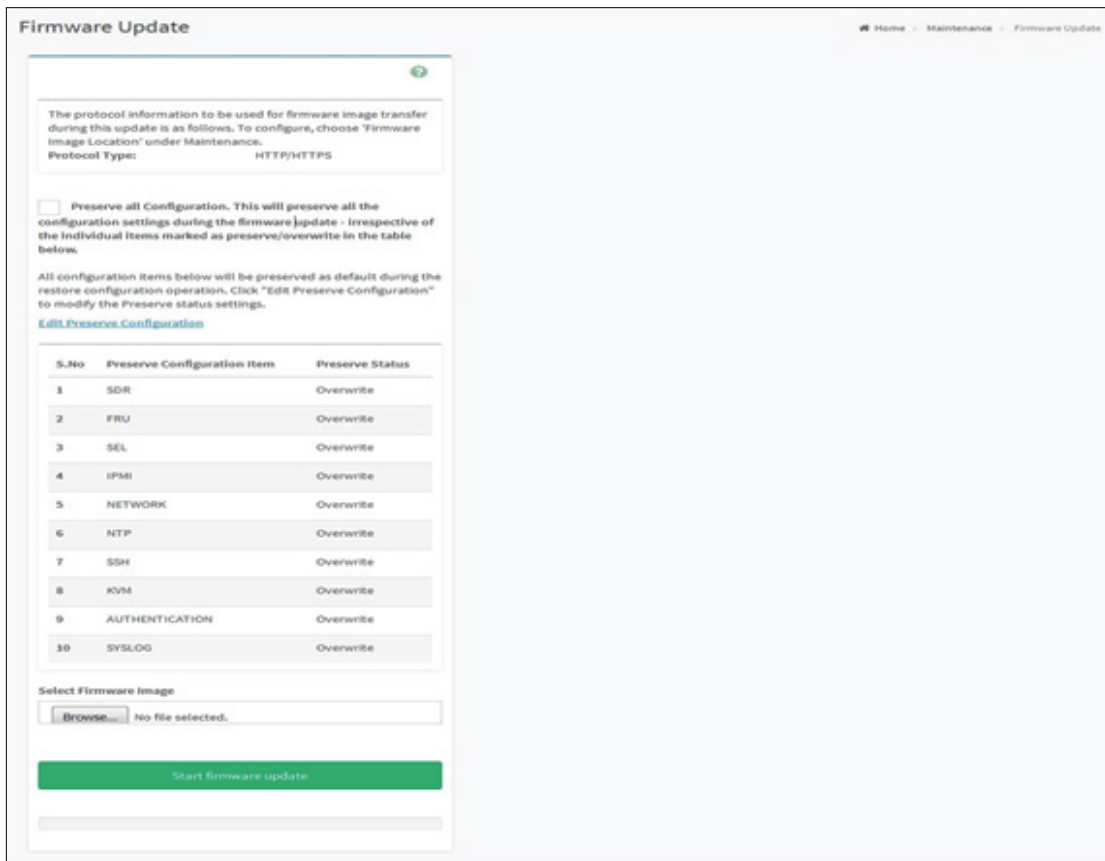

Firmware Update page

The various fields of Firmware Update are as follows.

- Preserve all Configuration: To preserve all configuration.
- Edit Preserve Configuration: To modify the Preserve status settings.
- Select Firmware Image: To Select the Firmware image to be uploaded.
- Start Firmware Update: To Start the Firmware Update.

This wizard takes you through the process of AMI based firmware upgradation. The protocol information to be used for firmware image transfer during this update is as follows.

NOTE

All configuration items will be preserved/overwrite as default during the restore configuration operation.

Procedure

1. Click Preserve all Configuration to preserve all configuration.
2. Click Browse to select firmware image. The Firmware update undergoes the following steps:
 - a. Closing all active client requests
 - b. Preparing Device for Firmware Upgrade
 - c. Uploading Firmware Image

NOTE

A file upload pop-up will be displayed for http/https but in the case of tftp files, the file is automatically uploaded displaying the status of upload.

- d. Browse and select the Firmware image to flash and click Upload.
- e. Click Start firmware update start the Firmware Update. A warning message will be prompted you to proceed further.
- f. Click OK to start the Firmware Update. The sample screenshot is shown below.

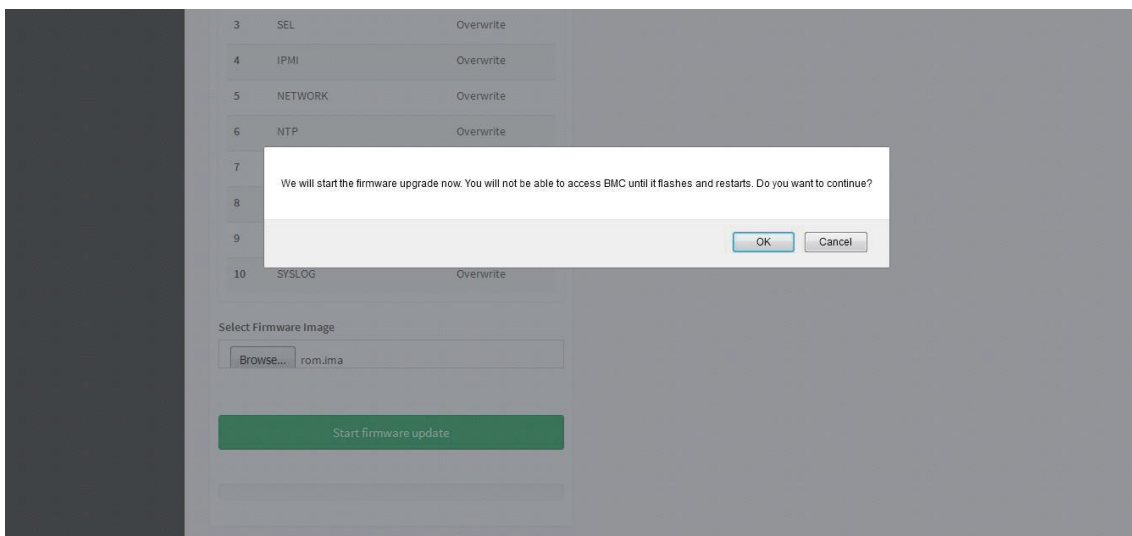

Firmware Update page - Image Upload

g. Verifying Firmware Image

In Section Based Firmware Update, you can configure the firmware image for section based flashing. Check the required sections and click Proceed to update the firmware.

If flashing is required for all images, select the option Full Flash .

If you select Version Compare Flash option from web, the current and uploaded module versions, FMHLocation, size will be compared.

If the modules differ in size and location, proceed with force firmware upgrade. If all the module versions are same, restart BMC by saying all the module versions are similar.

If only few module versions are differ, those module will be flashed.

NOTE
Only selected sections of the firmware will be updated. Other sections are skipped. Before starting flash operation, you are advised to verify the compatibility between image sections.

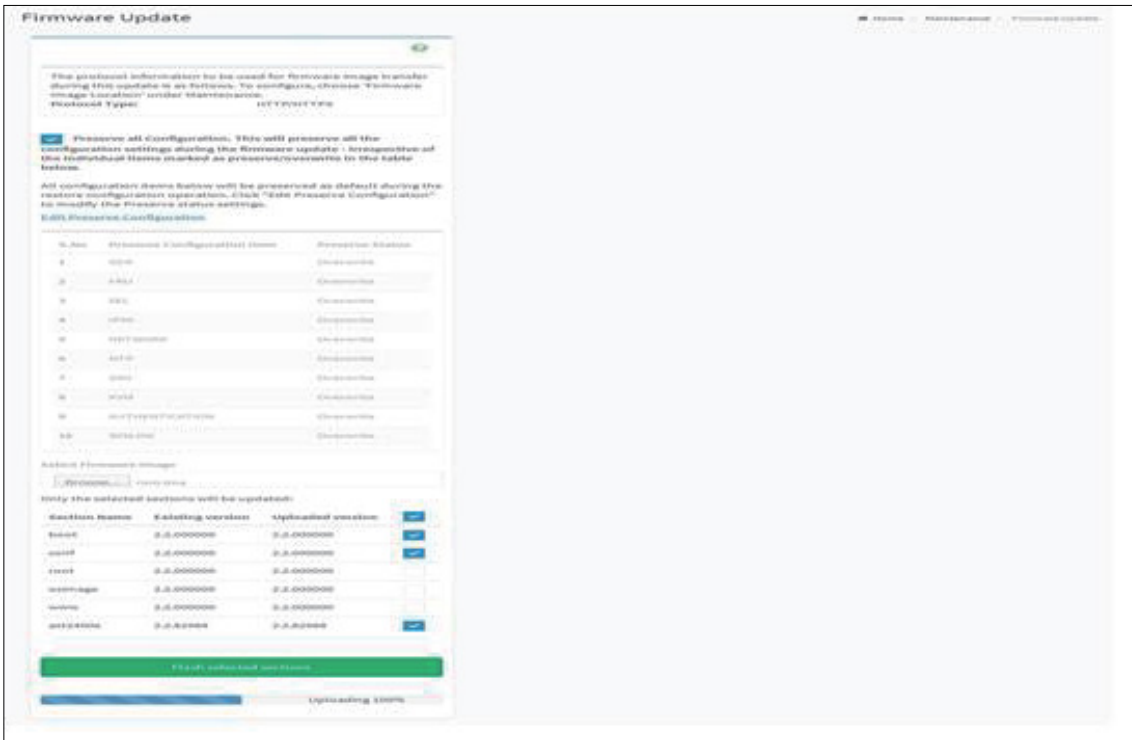

Section Based Firmware Flashing

- h. Flashing Firmware Image
- i. Resetting the image. The samplae screenshot of Firmaware update is as shown below.

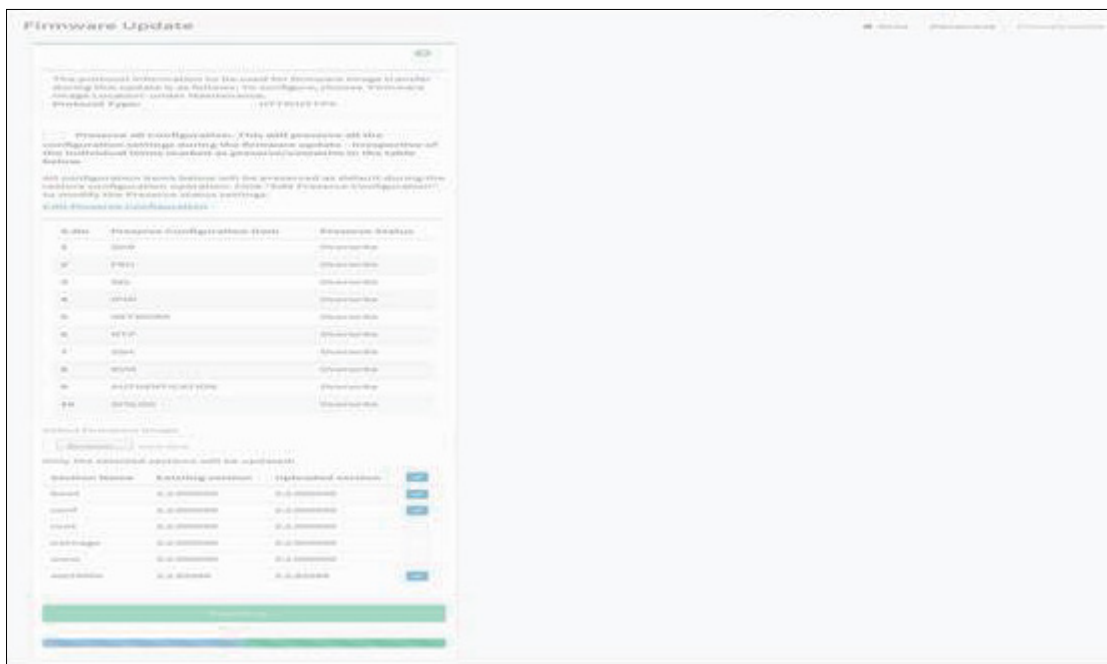

Firmware Update page

NOTE

The Firmware Update page will be disabled and you will not be able to perform any other tasks until firmware upgrade is completed and the device is rebooted. You can now follow the in- structions presented in the subsequent pages to successfully update the card’s firmware. The device will reset if update is canceled. The device will also reset upon successful completion of firmware update.

5.3.10 BIOS Firmware Update

This wizard takes you through the process of host BIOS firmware upgradation. A screenshot of BIOS Firmware Update is as shown below.

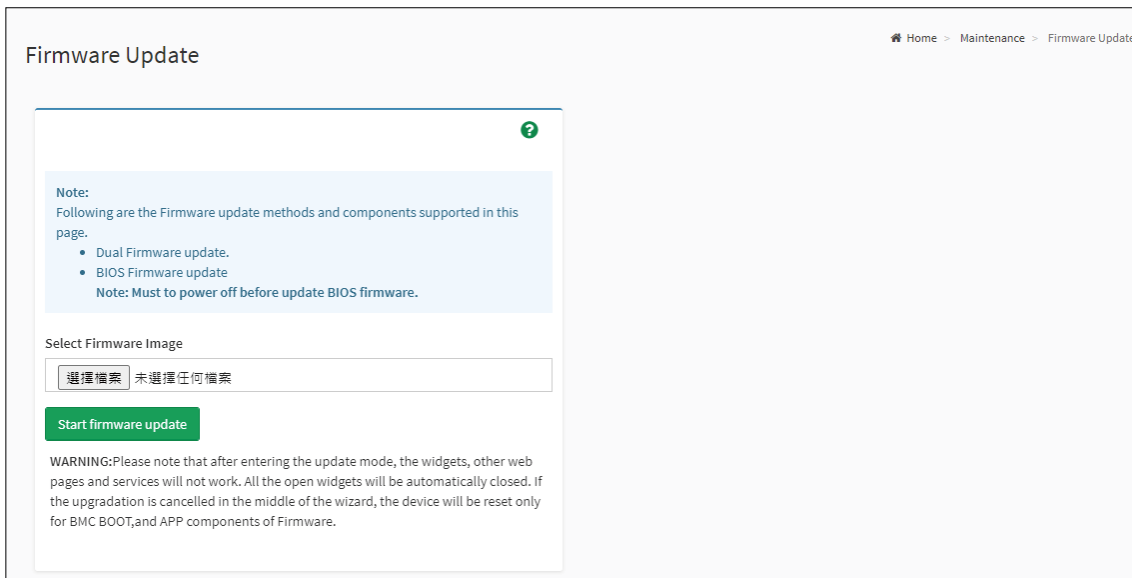

BIOS Firmware Update page

NOTE

The host will be forced to shutdown, if it is power on.

The various are listed below.

Select Firmware Image: Click Browse to select the HPMBIOS firmware update in .binhpm format.

Start Firmware Update: The firmware update will be started to flash.

Procedure to proceed BIOS Firmware Update

1. The Firmware update undergoes the following steps:
 - a. Click Browse and select the Firmware image to be flashed and click Start Firmware update to upgrade the current device firmware.
 - b. Preparing Device for Firmware Upgrade.
 - c. Uploading Firmware Image.
 - d. Flashing the image. The sample screenshot of BIOS Firmware update is as shown below.

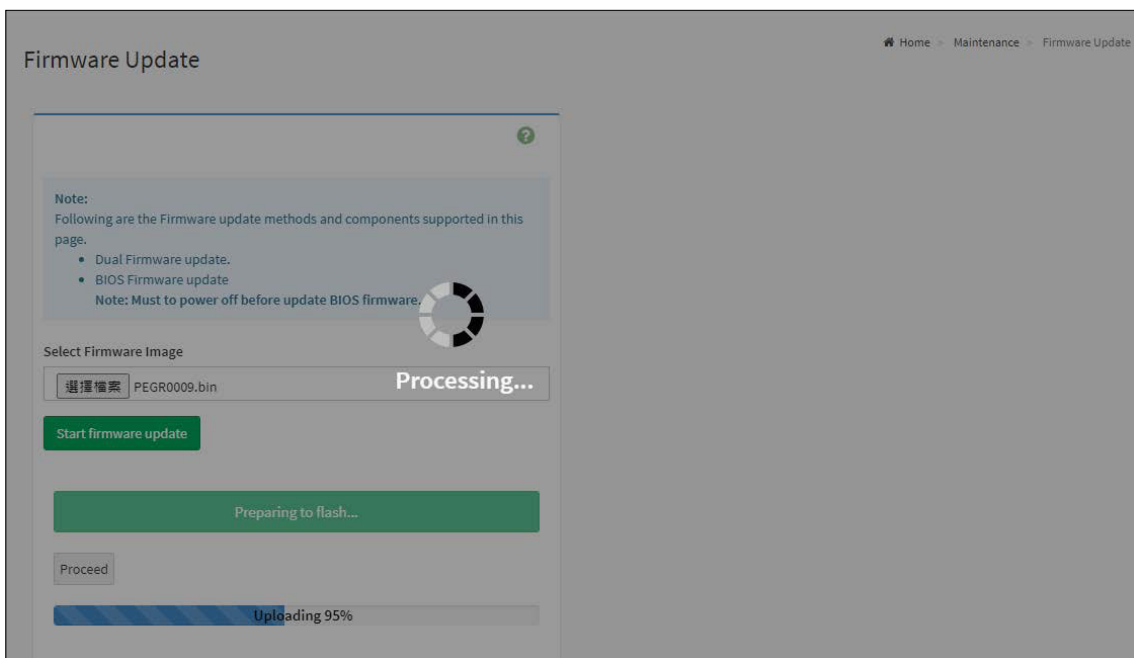

BIOS Firmware Update page

NOTE
You will not be able to perform any other tasks until firmware upgrade is completed and the device is off.

Chapter 6. Technical Support



www.aicipc.com

Taiwan, Global Headquarters

Address: No. 152, Section 4,
Linghang N. Rd, Dayuan District,
Taoyuan City 337, Taiwan

Tel: +886-3-433-9188

Fax: +886-3-287-1818

Sales Email: sales@aicipc.com.tw

Support Email: support@aicipc.com

Shanghai, China

Address: Room 1009, No. 777,
Zhaojia Bang Rd, Shanghai 200032,
Shanghai, China

Tel: +86-21-54961421

Fax +86-21-54961422 #608

Sales Email: csales@aicipc.com.tw

Support Email: support@aicipc.com

Moscow, Russia

Address: No.500, 5th Floor, 5th Entrance, 32A,
Khoroshevskoye Shosse, Moscow, 123007

Tel: +7-4997019998

Sales Email: support-ru@aicipc.com.tw

Support Email: support-ru@aicipc.com.tw

North California, United States

Address: 48531 Warm Springs
Boulevard Suite 404 Fremont, CA
94539, United States

Tel: +1-510-573-6730

Fax: +1-510-573-6729

Sales Email: sales@aicipc.com

Support Email: support@aicipc.com

South California, United States

Address: 21808 Garcia Lane
City of Industry, CA 91789,
United States

Toll free: +7-4997019998

Tel: +1-909-895-8989

Fax: +1-909-895-8989#157

Sales Email: sales@aicipc.com

Support Email: support@aicipc.com

New Jersey, United States

Address: 11 Melanie Lane
Unit #20 & 21

East Hanover, NJ 07936

United States

Tel: +1-973-884-8886

Fax: +1-973-884-4794

Sales Email: sales@aicipc.com

Support Email: support@aicipc.com

Houten, The Netherlands

Address: Peppelkade 58, 3992AK, Houten,
The Netherlands

Tel: +31-30-6386789

Fax: +31-30-6360638

Sales Email: sales@aicipc.nl

Support Email: support@aicipc.com