



SB401-VG

**Storage Barebone
User's Manual**

Table of Contents

Preface	i
Safety Instructions	ii
About This Manual	iv
Chapter 1. Product Features	1
1.1 Box Contents	1
1.2 Specifications	2
1.3 System Block Diagram	3
1.4 Features	4
Chapter 2. Hardware Setup	8
2.1 Central Processing Unit	8
2.1.1 Processor Installation	8
2.1.2 Air Duct	11
2.2 System Memory	12
2.2.1 DIMM Installation Order	13
2.2.2 DCPMM DIMM Population	15
2.2.3 DIMM Installation	16
2.3 Top Cover	17
2.4 Power Supply Unit	18
2.4.1 Replacing the Power Supply Unit	18
2.4.2 LED	18
2.5 Fan	19
2.6 Hard Disk Drive	20
2.6.1 Hard Disk Drive: 3.5-inch	20
2.6.2 Hard Disk Drive: 2.5-inch	21
2.6.3 LED	22
2.6.4 Drive Slot Map	23
2.7 Slide Rail	24
Chapter 3. Hardware Settings	27
3.1 Motherboard	27
3.1.1 Block Diagram	27
3.1.2 Content List	28
3.1.3 Placement	29
3.1.4 Connector	30
3.1.5 Jumper	34
3.1.6 Internal LED	36
3.1.7 Rear I/O Panel	37
3.2 HDD Backplane: 2 Bay	38
3.2.1 Connector Location	38
3.2.2 Connector	39
3.3 HDD Backplane: 24 Bay	40
3.3.1 Placement	40
3.3.2 Connector Location	41
3.3.3 Connectors	41
3.3.4 Jumper	44
3.3.5 Internal LED	44
3.3.6 Cable Routing	45
Chapter 4. BIOS Configuration Settings	46

4.1 Navigation Keys.....	46
4.2 BIOS Menu	47
4.3 Main	48
4.3.1 Main	48
4.4 Advanced	49
4.4.1 Peripheral Configuration.....	49
4.4.2 Video Configuration	49
4.4.3 OEMBoard Function	49
4.4.4 SIO AST2500	50
4.4.5 Socket Configuration	50
4.4.6 ME Configuration	56
4.4.7 PCH Configuration	57
4.4.8 H2O IPMI Configuration.....	58
4.4.9 APEI Configuration.....	58
4.4.10 Console Redirection.....	58
4.4.11 H2O Event Log Config Manager.....	59
4.4.12 H2oUve Configuration	59
4.5 Security	60
4.5.1 Security	60
4.6 Power	61
4.6.1 Power	61
4.7 Boot.....	62
4.7.1 Boot.....	62
4.8 Exit.....	63
4.8.1 Exit.....	63
Chapter 5. BMC Configuration Settings	64
5.1 Setup	64
5.2 Web GUI	67
Chapter 6. RAID Configuration.....	71
6.1 Mirrored Volume Configuration.....	71
6.1.1 Create Mirrored Volumes.....	71
6.1.2 Create Integrated Mirroring Volume	71
6.1.3 Create an Integrated Mirroring Enhanced/Mirroring + Striping Volume.....	72
6.1.4 Expand an Integrated Mirroring Volume with OCE.....	73
6.2 Manage Hot Spare Disks	74
6.2.1 Create Hot Spare Disks.....	74
6.2.2 Delete a Hot Spare Disk	75
6.3 Other Configuration Tasks.....	75
6.3.1 View Array Properties	75
6.3.2 Run a Consistency Check	75
6.3.3 Activate an Array	76
6.3.5 Locate Disk Drives in a Volume.....	76
6.3.6 Select a Boot Disk	77
6.4 Integrated Striping	78
6.4.1 Integrated Striping Configuration.....	78
6.4.2 Create Integrated Striping Volumes.....	78
6.4.3 Other Configuration Tasks.....	79
6.5 Intel® RSTe	81
Chapter 7. Technical Support.....	82



Copyright © 2019 AIC, Inc. All Rights Reserved.

This document contains proprietary information about AIC products and is not to be disclosed or used except in accordance with applicable agreements.

Document Release History

Release Date	Version	Update Content
Decmeber 2019	1	Released to public.
March 2020	1.1	SW update.
August 2021	1.2	RAID update. System Block Diagram update.

Preface

Copyright

No part of this publication may be reproduced, stored in a retrieval system, or transmitted in any form or by any means, electronic, mechanical, photo-static, recording or otherwise, without the prior written consent of the manufacturer.

Trademarks

All products and trade names used in this document are trademarks or registered trademarks of their respective holders.

Changes

The material in this document is for information purposes only and is subject to change without notice.

Warning

1. A shielded-type power cord is required in order to meet FCC emission limits and also to prevent interference to the nearby radio and television reception. It is essential that only the supplied power cord be used.
2. Use only shielded cables to connect I/O devices to this equipment.
3. You are cautioned that changes or modifications not expressly approved by the party responsible for compliance could void your authority to operate the equipment.

Disclaimer

AIC shall not be liable for technical or editorial errors or omissions contained herein. The information provided is provided "as is" without warranty of any kind. To the extent permitted by law, neither AIC or its affiliates, subcontractors or suppliers will be liable for incidental, special or consequential damages including downtime cost; lost profits; damages relating to the procurement of substitute products or services; or damages for loss of data, or software restoration. The information in this document is subject to change without notice.

Instruction Symbols

Special attention should be given to the instruction symbols below.



NOTE

This symbol indicates that there is an explanatory or supplementary instruction.



CAUTION

This symbol denotes possible hardware impairment. Upmost precaution must be taken to prevent serious hardware damage.



WARNING

This symbol serves as a warning alert for potential body injury. The user may suffer possible injury from disregard or lack of attention.

Safety Instructions

Before you commence, please attentively read the following important discretions below. All cautions and warnings on the equipment or in the manuals should be circumspactly noted and reviewed.

Always ground yourself to prevent static electricity.

請全程接地，以防止靜電。

请全程接地，以防止静电。

Всегда заземляйте себя, чтобы избежать статического электричества.

Aard jezelf altijd om statische elektriciteit te voorkomen.

- Firmly ground yourself at all times when installing or assembling the internal components of the server. Most of electronic components in the server are highly sensitive to electrical static discharge.
- Use a solid grounding wrist strap and distintively place all electronic components in static-shielded devices to prevent static. Grounding wrist straps can be purchased in any electronic supply store.
- Confirm that the power source is turned off and then disconnect the power cords from your system before performing any type of installation or manual servicing. A sudden surge of power could serverly damage the sensitive electronic components.
- Do not precipitously open the system's top cover. If you must open the cover for maintenance purposes, only a trained technician should be allowed to proceed this action. Integrated circuits on computer boards are highly sensitive to static electricity. Before operating a board or integrated circuit, touch an unpainted portion of the system unit chassis for a couple of seconds to discharge any static electricity on your body.

Place the server in a stable environment.

請將伺服器放置在穩定的環境中。

请将伺服器放置在穩定的環境中。

Поместите сервер в стабильную среду.

Plaats de server in een stabiele omgeving.

- Place this equipment on a stable surface when installing. A small mild drop or fall could cause fatal injury to both the equipment and the person handling the equipment.
- Please keep this equipment away from humidity to prevent vast rust and disintergration.
- Carefully and accurately mount the equipment into the rack. Uneven mechanical loading may lead to hazadous consequences.
- This equipment is to be installed for operation in an environment with maximum ambient temperature below 35°C.
- Review the environment before performing any installation or servicing. Keep the equipment away from hazardous and uneven grounds.
- This server must be installed only in Restricted Access Locations.

Handle equipment with care.

請謹慎操作設備。

请谨慎操作设备。

Обращайтесь с оборудованием осторожно.

Behandel de apparatuur voorzichtig.

- Do not cover the openings of the system. The openings on the system are for air convection, which intentionally protect the equipment from overheating.
- Never pour any liquid into ventilation openings of the system. This could cause catastrophic fire or electrical shock.

- Ensure that the voltage of the power source is within the specification on the label when connecting the equipment to the power outlet. The current load and output power of loads must be within the specification.
- This equipment must be firmly connected to reliable grounding before usage. Pay special attention to power supplied other than direct connections, e.g. using of power strips.
- Place the power cord out of the way of foot traffic. Do not place anything over the power cord. The power cord must be rated for the product, voltage and current marked on the product's electrical ratings label. The voltage and current rating of the cord should be greater than the voltage and current rating marked on the product.

Pay attention to hardware maintenance.

注意硬體維護。

注意硬體維護。

Обратите внимание на обслуживание оборудования.

Besteed aandacht aan hardware-onderhoud.

- If the equipment is not used for a long time, disconnect the equipment from mains to avoid being damaged by transient over-voltage.
- Module and drive bays must not be empty. They must have a dummy cover.
- Never open the equipment without professional assistance. For safety reasons, only qualified service personnel should open the equipment.
- If one of the following situations arise, the equipment should be checked and tested by service personnel:
 1. The power cord or plug is damaged.
 2. Liquid has penetrated the equipment.
 3. The equipment has been exposed to moisture.
 4. The equipment does not work well or will not work according to its user manual.
 5. The equipment has been dropped and/or damaged.
 6. The equipment has obvious signs of breakage.
 7. Please disconnect this equipment from the AC outlet before cleaning. Do not use liquid or detergent for cleaning. The use of a moisture sheet or cloth is recommended for cleaning.



CAUTION

The equipment intended for installation should be placed in Restricted Access Location.



CAUTION

There will be a risk of explosion if battery is replaced by an incorrect type. Dispose of used batteries according to the instructions. After performing any installation or servicing, make sure the enclosure is correct in position before turning on the power.



CAUTION

This unit may have more than one power supply. Disconnect all power sources before maintenance to avoid electric shock.



About This Manual

Thank you for selecting and purchasing the SB401-VG.

This user's manual is provided for professional technicians to perform easy hardware setup, basic system configurations, and quick software startup. This document pellucidly presents a brief overview of the product design, device installation, and firmware settings for SB401-VG. For the latest version of this user's manual, please refer to the AIC website: <https://www.aicipc.com/en/productdetail/50999>.

Chapter 1 Product Features

SB401-VG is a flexible storage server barebone that is specifically designed to accommodate diverse corporations and enterprises for managing heavy workloads and multiple applications.

Chapter 2 Hardware Setup

This chapter displays an easy installation guide for assembling the hardware in this product. Utmost caution for proceeding to set up the hardware is highly advised. Most of the components are highly fragile and vulnerable to exterior influence. Do not endanger the device by placing the device in an unstable environment.

Chapter 3 Motherboard Settings

This chapter elaborates the overall layout of the server motherboard, including multifarious connectors, jumpers, and LED descriptions. These descriptions assist users to configure different settings and functions of the motherboard, as well as to confirm the location of each connector and jumper.

Chapter 4 BIOS Configuration Settings

This chapter introduces the key features of BIOS, including the descriptions and option keys for diverse functions. These details provide users to effortlessly navigate and configure the input/output devices.

Chapter 5 BMC Configuration Settings

This chapter illustrates the diverse functions of IPMI BMC, including the details on logging into the web page and assorted definitions. These descriptions are helpful in configuring various functions through Web GUI without entering the BIOS setup. For more information of BMC configurations, please refer to IPMI BMC (Aspeed AST2500) User's Manual for a more detailed description.

Chapter 6 RAID Configuration

This chapter provides details about how to manage and configure RAID in SATA/SAS/SSD systems through BIOS CU.

Chapter 7 Technical Support

For more information or suggestion, please contact the nearest AIC corporation representative in your district or visit the AIC website: <https://www.aicipc.com/en/index>. It is our greatest honor to provide the best service for our customers.

Chapter 1. Product Features

SB401-VG is a high density storage server that includes mother board, chassis, power supply, and HDD backplane. For more information about our product, please visit our website at <https://www.aicipc.com/en/index>.

Before removing the subsystem from the shipping carton, visually inspect the physical condition of the shipping carton. Exterior damage to the shipping carton may indicate that the contents of the carton are damaged. If any damage is found, do not remove the components; contact the dealer where the subsystem was purchased for further instructions. Before continuing, first unpack the subsystem and verify that the number of components in the shipping carton is accurate and in good condition

1.1 Box Contents

This product contains the components listed below. Please confirm the number and the condition of the components before installation.

- Chassis
(includes power supply, fan
& hard disk drive tray)
- Power cord (vary per region)
- 28" Slide rail x 1 set (optional)

Product features are subject to change without notice.

1.2 Specifications

Dimensions (W x D x H)	mm : 430 x 680 x 174.3		
	inches : 16.9 x 26.8 x 6.9		
Motherboard	AIC Server Board Virgo		
Processor	Processor Support	<ul style="list-style-type: none"> Intel® Xeon® Scalable Processors (Skylake/Cascade Lake/Cascade Lake Refresh) Supports CPU TDP up to 165W (Use over 140W CPU, please contact AIC technical support more info/details about optimized CPUs and specialized system.) 	
	UPI Speeds	10.4 GT/s, 9.6 GT/s	
	Socket Type	Socket P0 (LGA-3647 Socket)	
Chipset Support	Intel® Lewisburg C620 series PCH		
System Memory	<ul style="list-style-type: none"> 6 x memory channels per CPU, 1 x DIMM per channel 12 x DIMM slots support: 2933/2666/2400MHz <ul style="list-style-type: none"> up to 192GB RDIMM SRx4 up to 384GB RDIMM DRx4 up to 1536GB RDIMM 3DS 8Rx4 up to 768GB LRDIMM QRx4 up to 1536GB LRDIMM 3DS 8Rx4 Intel® NVM DIMM (Apache Pass) support 		
Front Panel	System power on/off, System ID, System reset, 2x USB 3.0 Type A		
LEDs	Power status, System alert, LAN activity, Drive activity, System ID		
Drive Bays	External	3.5" hot swap	24
		2.5" hot swap	2 (15mm, rear)
Backplane	Options	1 x 24-port 12Gb SAS backplane with 36-PHY expander and 3 SFF-8643 connectors	
		1 x 24-port 12Gb SAS passive backplane with 6 SFF-8643 + 4 x NVMe U.2 connectors (BTO)	
		1 x 24-port 12Gb SAS backplane with 6 SFF-8643 connectors (BTO)	
Rear I/O	LAN	<ul style="list-style-type: none"> 2 x 10GbE SFP+ 1 x10/100M RJ45 dedicated to BMC management 	
	USB	2 x USB 3.0 Type A	
	VGA	1 x external DB-15 VGA port	
	Serial Port	1 x external DB-9 COM port	
TPM (Optional)	TPM Support	1 x TPM 2.0 onboard	
Power Supply	1200W 1+1 redundant power supply 80+ Platinum <ul style="list-style-type: none"> AC INPUT : 100~127V,50/60Hz,10A DC OUTPUT : 800W AC INPUT : 200~240V,50/60Hz,8A DC OUTPUT : 1200W 		
System Cooling	3 x 120x25mm hot swap fans		
System Management	<ul style="list-style-type: none"> Baseboard Management Controller Intelligent Platform Interface 2.0 (IPMI 2.0) iKVM, Media Redirection, IPMI over LAN, Serial over LAN SMASH Support HTML5 Redfish 		
System Management	<ul style="list-style-type: none"> Baseboard Management Controller Intelligent Platform Interface 2.0 (IPMI 2.0) iKVM, Media Redirection, IPMI over LAN, Serial over LAN SMASH Support HTML5 Redfish 		
Expansion Slots	PCIe 3.0	<ul style="list-style-type: none"> 2 x16 slots (FHHL) 3 x8 slots (FHHL) 	
System BIOS	BIOS Type	Insyde UEFI BIOS	
	BIOS Features	<ul style="list-style-type: none"> ACPI PXE WOL AC loss recovery IPMI 2.0 KCS interface SMBIOS Serial console redirection 	<ul style="list-style-type: none"> BIOS Boot Specification BIOS Recovery Mode SRIOV iSCSI TPM PCIe Hotplug
On-board Devices	SATA/SAS	Intel® Lewisburg PCH on-chip solution <ul style="list-style-type: none"> 8 x SATA 6.0 Gb/s (by 2 x mini-SAS) + 2 x SATA 6.0 Gb/s (by 2 x SATA 7 pin) RAID 0, 1, 5, 10 support by Intel RSTe Broadcom SAS IOC SAS3008 supports up to 8 ports 12G SAS via 2 x mini-SAS HD (optional) 	
	BMC	Aspeed AST2500 Advanced PCIe Graphics & Remote Management Processor <ul style="list-style-type: none"> Baseboard Management Controller Intelligent Platform Interface 2.0 (IPMI 2.0) iKVM, Media Redirection, IPMI over LAN, Serial over LAN SMASH Support HTML5 Redfish 	
	Network Controllers	<ul style="list-style-type: none"> Intel® PCH (Lewisburg) Integrated 10GbE LAN Controller with dual 10GbE SFP+ + 2 x configurable ports support 10GbE (KR/SFI/XFI) or 1GbE (KX) (option) Realtek RTL8201EL for BMC dedicated management port 	
	Graphics	Aspeed AST2500 Advanced PCIe Graphics & Remote Management Processor <ul style="list-style-type: none"> PCIe VGA/2D Controller 1920x1200@60Hz 32bpp 	
Environmental Specifications	<ul style="list-style-type: none"> Storage temperature : -10°C(14°F) ~ 60°C(140°F) Operating temperature : 0°C(32°F) ~ 35°C(95°F) Storage operating humidity : 5%~95% non-condensing 		
Gross Weight	(w/ PSU & Rail)	kgs :	35
		lbs :	77
Packaging Dimensions	(W x D x H)	mm :	605 x 920 x 406
		inches :	23.8 x 36.2 x 16
Mounting	Standard	28" tool-less slide rail	



NOTE

This product don't support redundant function under 180 voltage AC inlet.

1.3 System Block Diagram

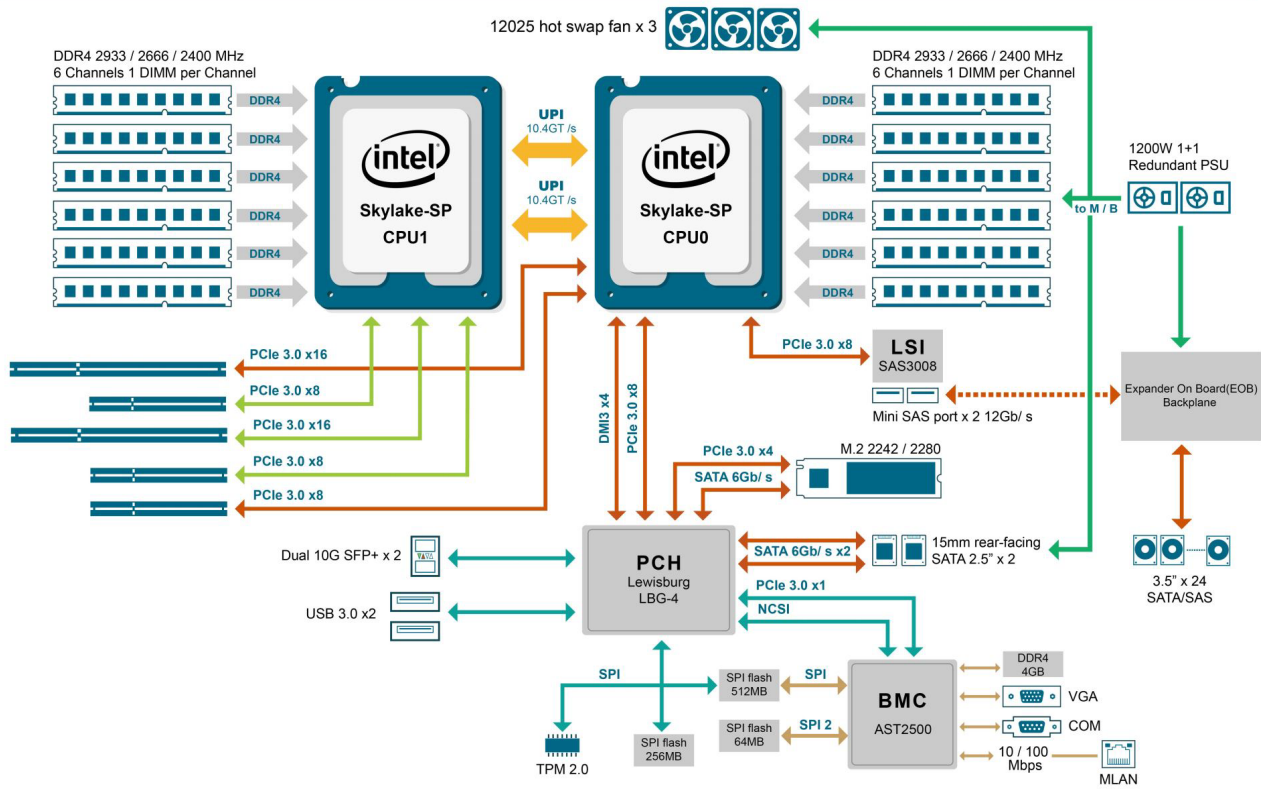

1.4 Features





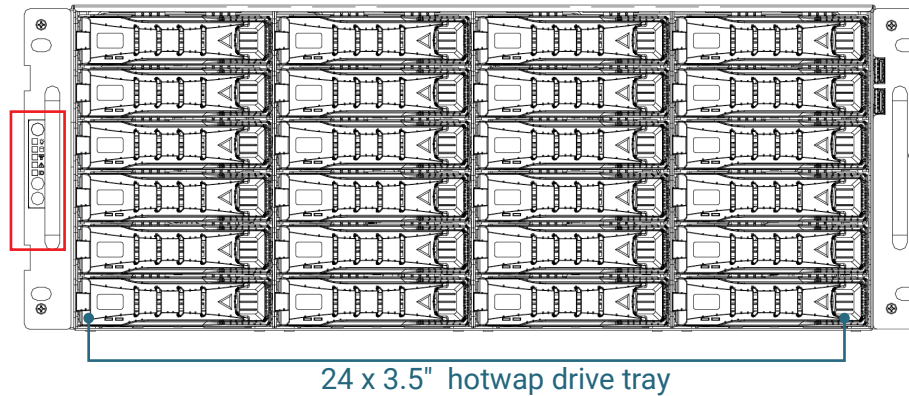

SB401-VG is a reliable 4U storage server barebone with 24 hotswap drives bays. This product is designed to accommodate the AIC-patented serverboard, Virgo, which supports two Intel® Xeon® Scalable Processors and 12 DDR4 DIMM to offer greater performance, efficiency, and utility for our customers. Featuring Intel® C620 Series Chipset, which is emphasized for its accelerated speed and expansion, this product enhances these advantages by integrating flexible IO usage and system expansion into to provide greater bandwidth and utilization.

In addition to the noteworthy features of the barebone, SB401-VG provides immediate and efficient management with Onboard Baseboard Management Controller and greater I/O extension. Featuring IPMI 2.0 and Aspeed AST2500 Advanced PCIe Graphics, the server board offers support for iKVM, Media Redirection, Smash Support, IPMI over LAN, and Serial over LAN.

- 4U 24-Bay general purpose storage server 24 hot swap 3.5" SAS drive bays
- Supports 2nd Gen. Intel® Xeon® Scalable Processors (Cascade Lake/Cascade Lake refresh/Skylake)
- With Intel® Lewisburg C620 series Chipset to provide 5+ years product life cycle
- Onboard Baseboard Management Controller for system management and IPMI control
- Front-to-back airflow and hot swap redundant fans to provide optimal thermal conditions
- Two 10GbE SFP+ ports plus dedicated BMC management port
- Customizable to meet your requirements

Front Panel



Item	Description
	Power Button
	Power Status LED Indicator
	LAN LED Indicator
	System Alert LED Indicator
	System ID LED
	System ID Button
	System Reset Button

LED Indicator

ID	Blue	UID activity is detected.
	Off	No UID activity is detected.
System Alert	Red	Critical system failure is detected (processors, memory, voltage regulators, thermal events, fan failures, NMI, etc).
	Off	No critical failure is detected.

Rear Panel

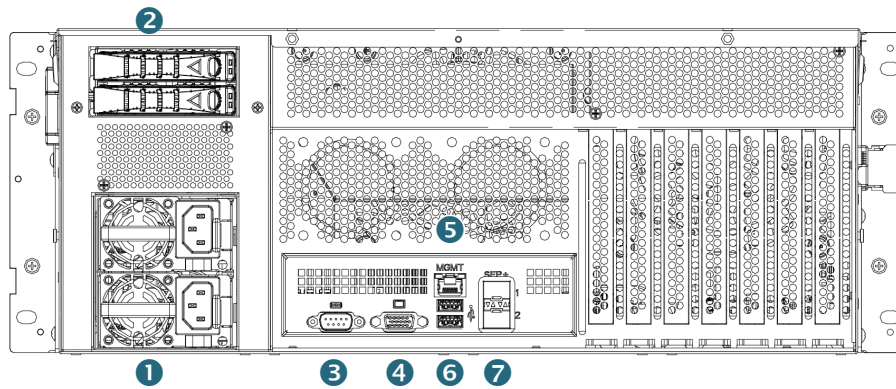

Item	Description
1	1200W 1+1 redundant power supply 80+ Platinum
2	2 x 2.5-inch hot swap drive (15mm)
3	1 x DB-9 COM port
4	1 x DB-15 VGA port
5	1 x GbE RJ45 dedicated to BMC management port
6	2 x USB 3.0 Type A
7	2 x 10 GbE SFP+ port

Top View

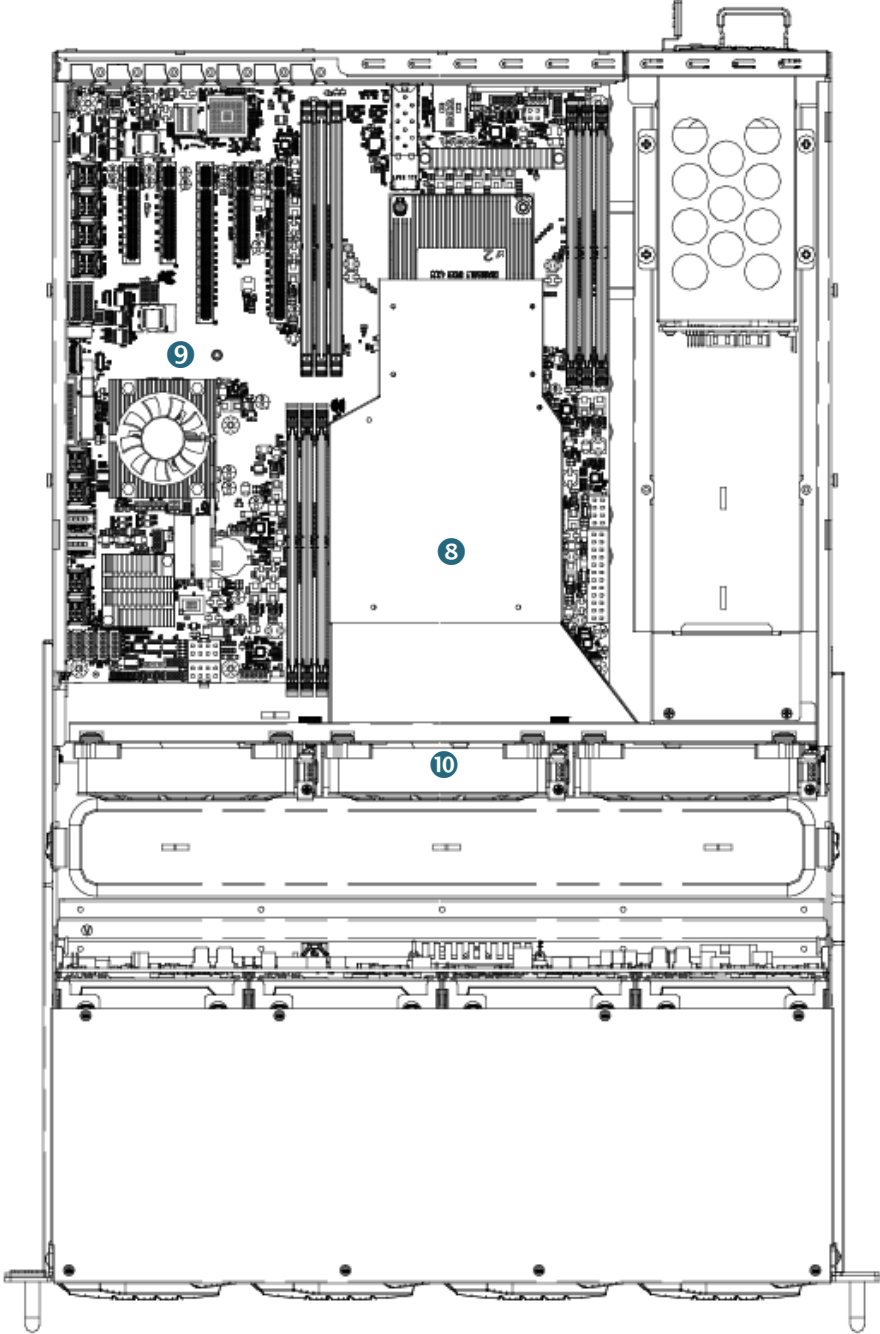

Item	Description
8	1 x Air duct
9	AIC- Virgo Motherboard
10	3 x 120x25 mm hot swap fans

Chapter 2. Hardware Setup

This section describes a simple instruction guide for installing the hardware components on the serverboard system. Turn off and unplug all system and peripheral devices before proceeding.

2.1 Central Processing Unit

The serverboard supports dual Xeon scalable processors and Socket P0 (LGA-3647).

2.1.1 Processor Installation

To ensure a safe and easy setup, you need to prepare before installation:

- a T20 Torx screwdriver
- ESD wrist strap/mat and conductive foam pad

CAUTION



The pins of the processor socket are vulnerable and easily susceptible to damage if fingers or any foreign objects are pressed against them. Please keep the socket protective cover on when the processor is not installed.

CAUTION



When unpacking a processor, hold the processor only by its edges to avoid touching the contacts.

Standard Processor Assembly:

A standard processor assembly is comprised of PHM(Processor Heat sink Module) components and processor socket assembly.

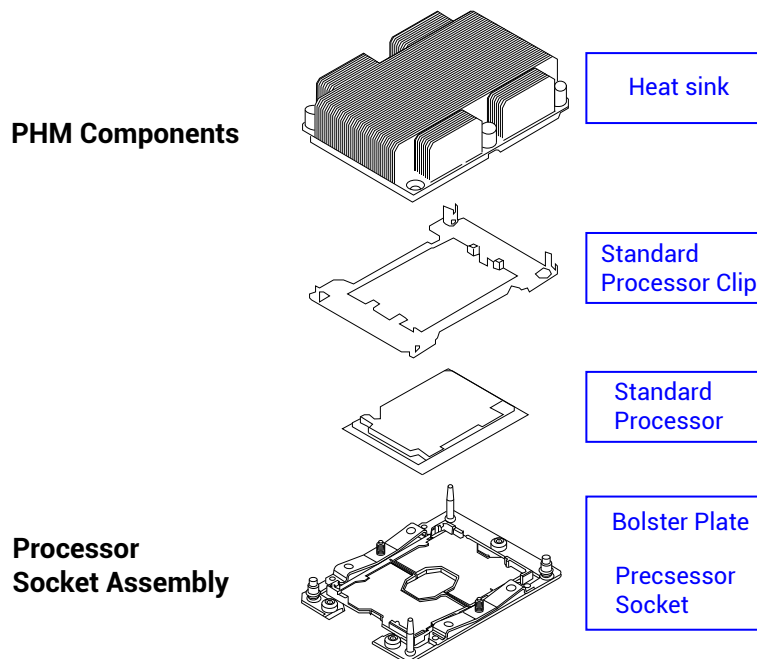

This information is provided for professional technicians only.

Processor Socket Assembly:

The server board includes two processor sockets (LGA-3647), supports two Intel® Xeon® Processor Scalable Family and has a Thermal Design Power (TDP) of up to 165W on selected models.

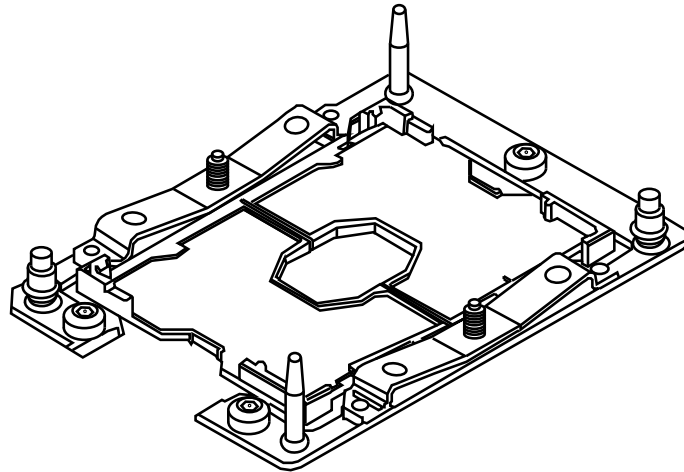
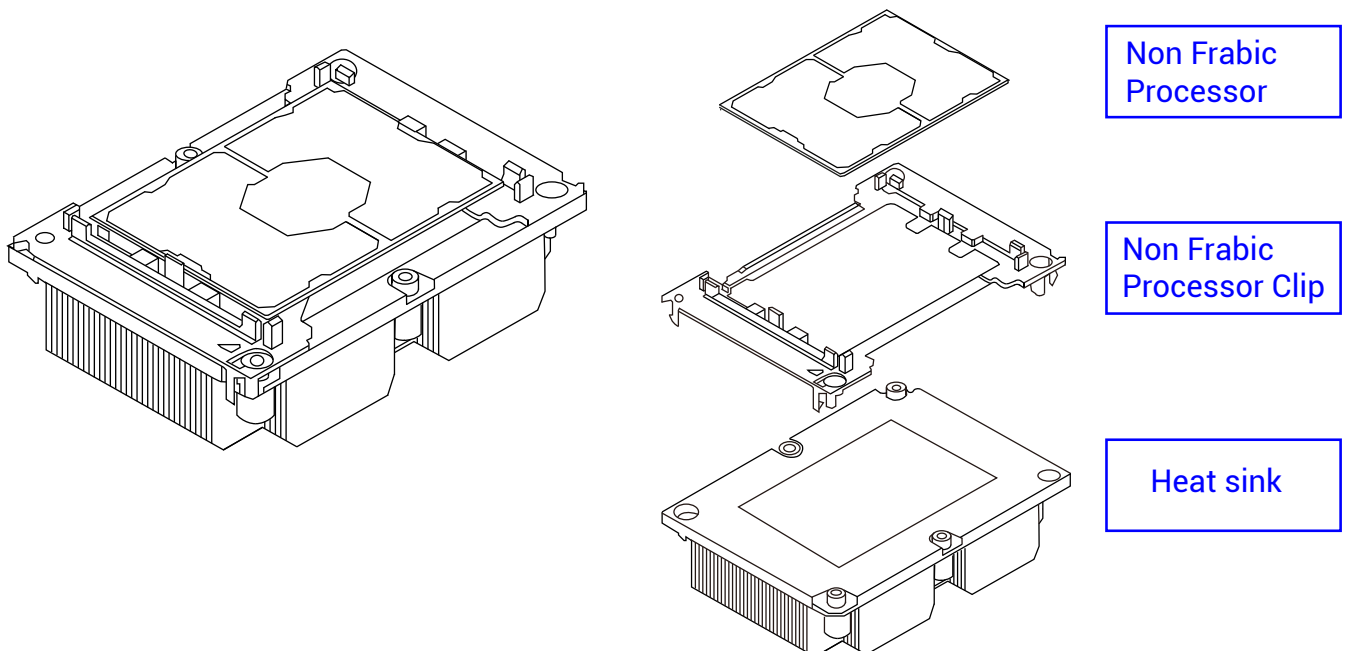
**PHM (Processor Heat sink Module) Component:**

This information is provided for professional technicians only.

PHM Screw Installation Order:

The PHM sits level with the processor socket assembly. The PHM is NOT installed properly if it does not sit level with the processor socket assembly. Once the PHM is seated over the processor socket assembly, the four heat sink torque screws must be secured in the following order as shown below.

Processor Heat Sink – Top View with Screw Tightening Order

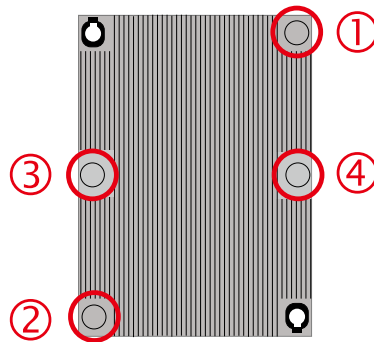
**CAUTION**

Failure to tighten the heat sink screws in the specified order may cause damage to the processor socket assembly. Heat sink screws should be tightened to 12 in-lbs torque according to the indicated order on the top of the heat sink label.



This information is provided for professional technicians only.

2.1.2 Air Duct

Position the air duct on top of the heatsink and secure the screw. Ensure that the air duct is accurately aligned.

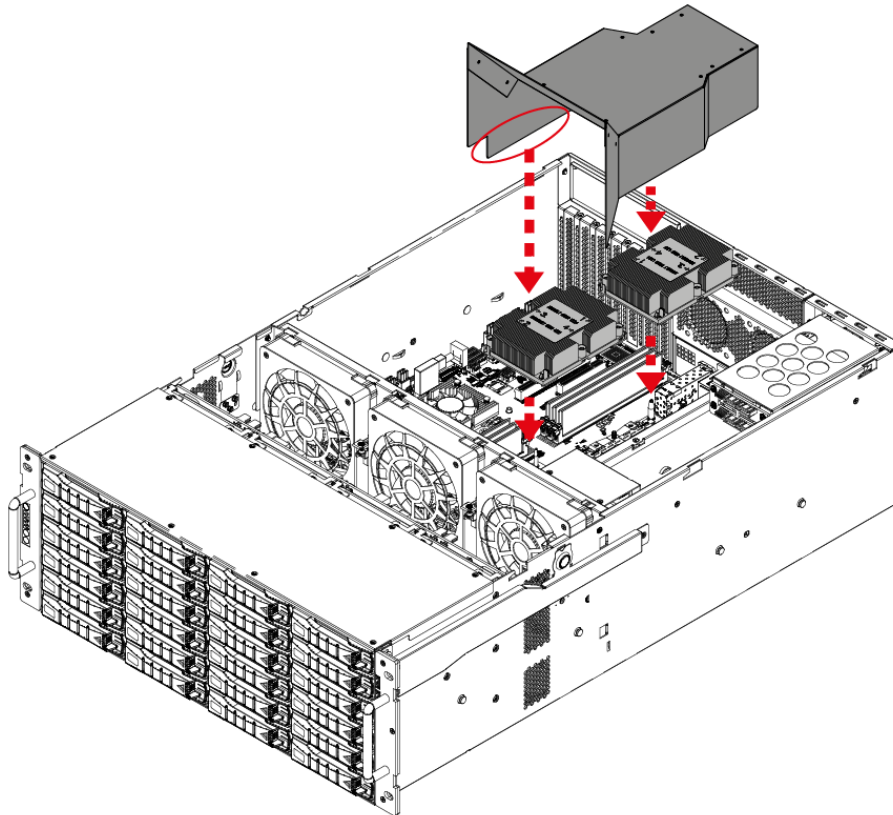

Air duct location
(Top view)

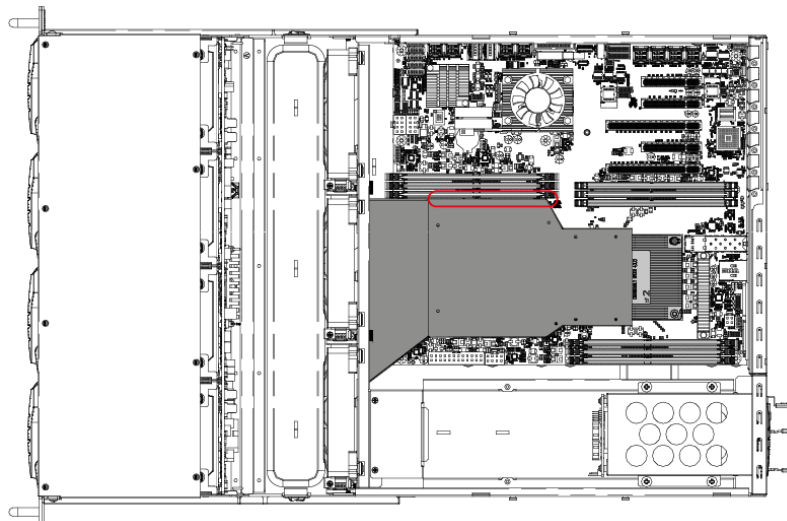

CAUTION



Avoid moving the heat sink after it has contacted the top of the CPU. Too much movement could disturb the layer of thermal compound, causing voids, and leading to ineffective heat dissipation and component damage.



This information is provided for professional technicians only.

2.2 System Memory

This server board supports up to twelve DDR4 2400 and 2666 Registered ECC DRAM/ Load-Reduced DIMM.

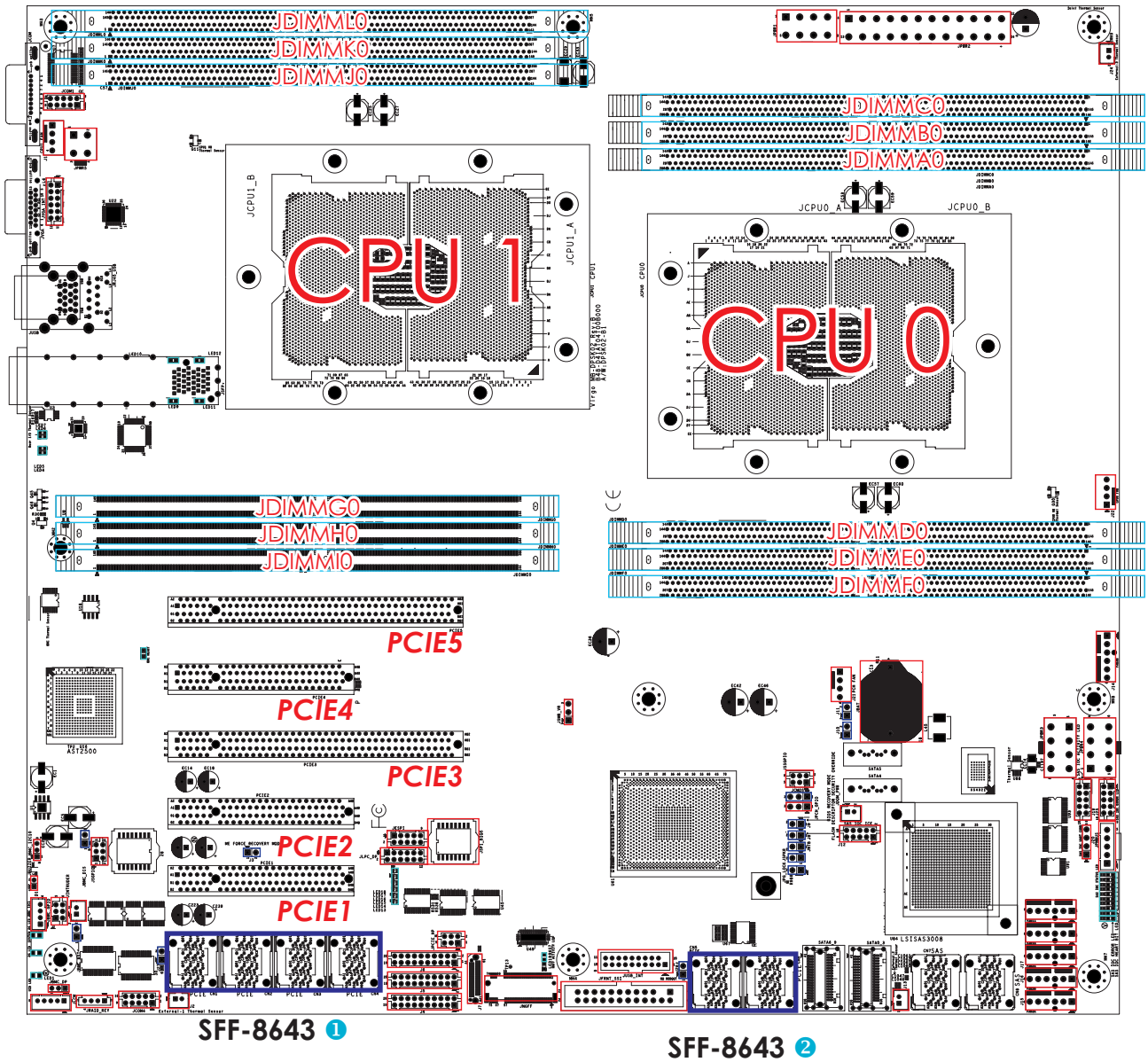

NOTE



- In Virgo case, the lanes from CPU#0 are routed to PCIe slots 1 & 5 and onboard SFF-8643.
- The lanes from CPU#1 are routed to PCIe slots 2/3/4 and the onboard SFF-8643.

2.2.1 DIMM Installation Order

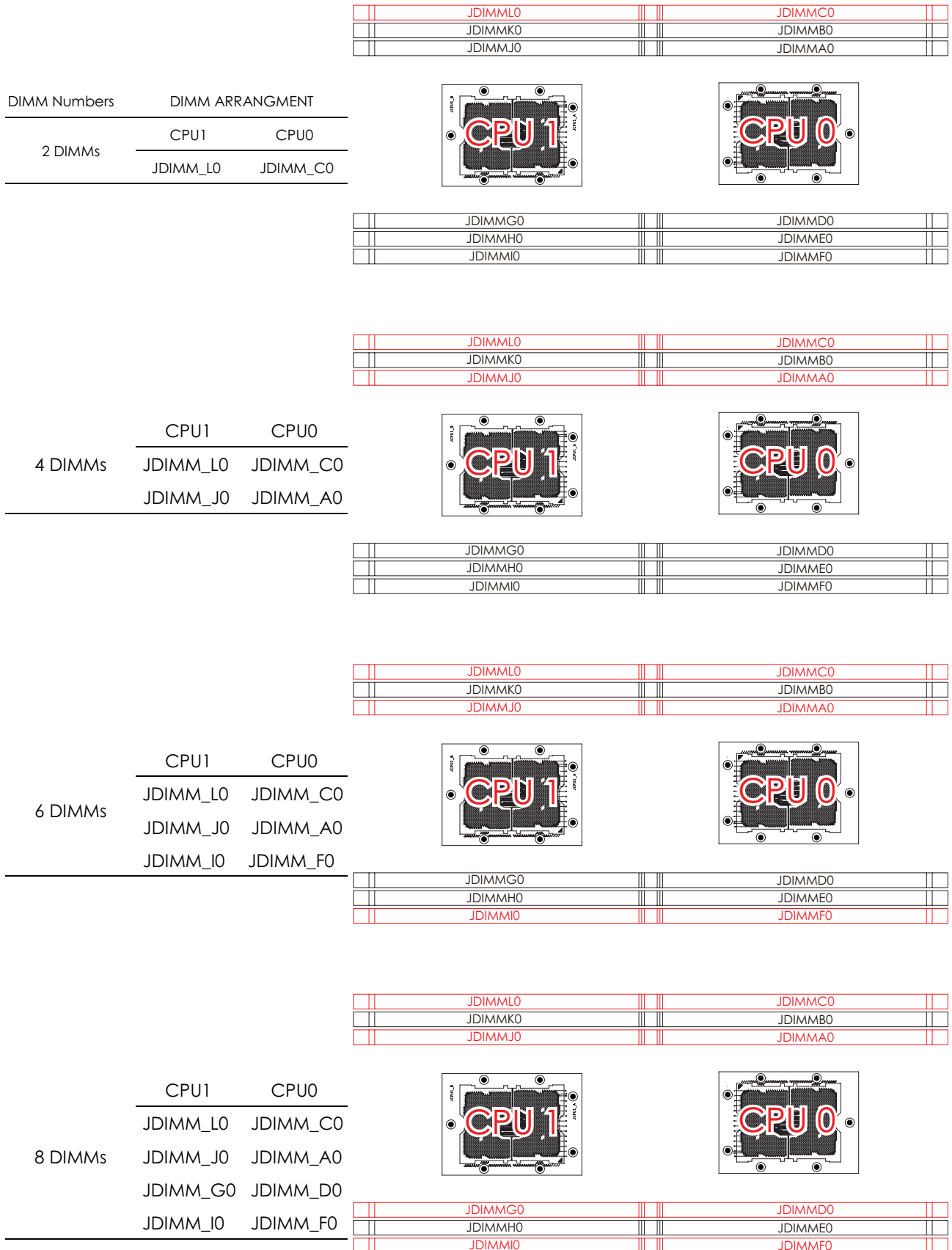

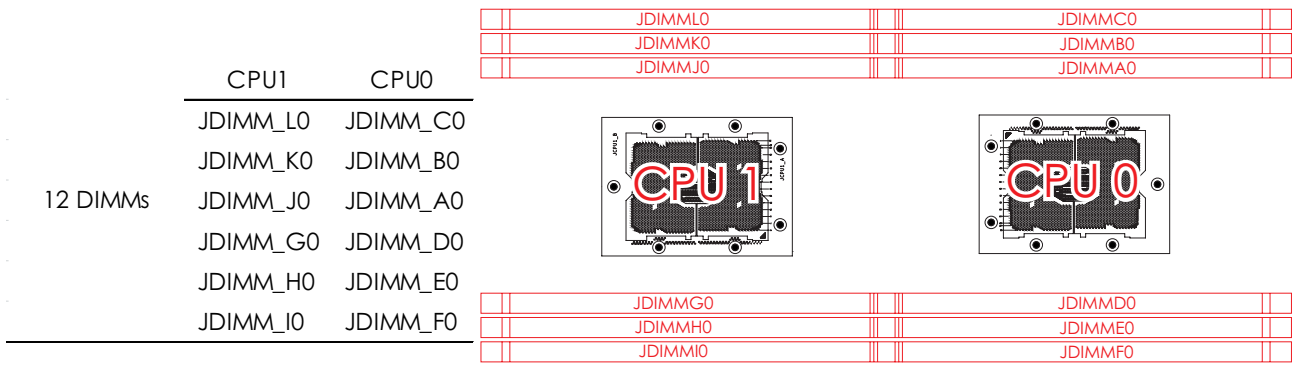
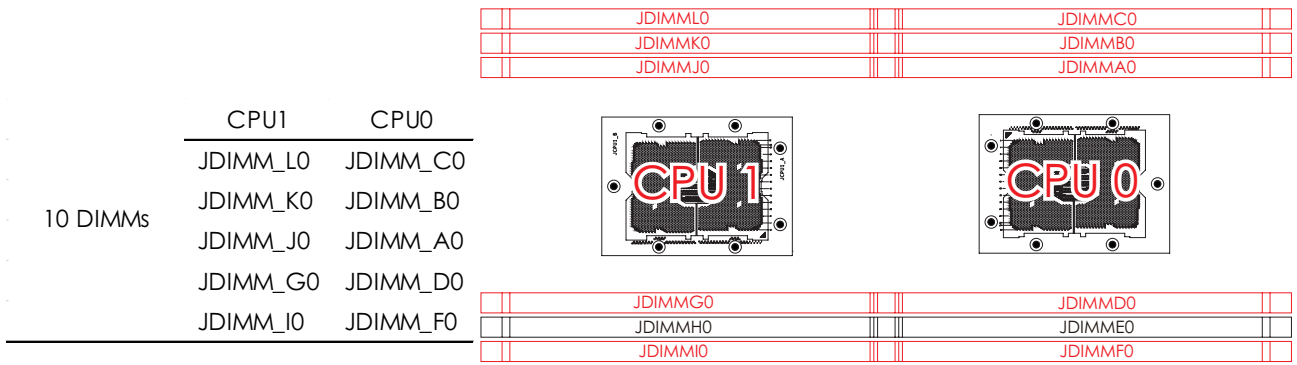

2.2.2 DCPMM DIMM Population

DIMM	CPU0						CPU1					
	JDIMMF0	JDIMME0	JDIMMD0	JDIMMA0	JDIMMB0	JDIMMC0	JDIMML0	JDIMMK0	JDIMMJ0	JDIMMG0	JDIMMH0	JDIMMI0
App Direct Mode	DCPMM	DRAM1	DRAM1	DRAM1	DRAM1	DCPMM	-	-	-	-	-	-
Memory Mode	DCPMM	DRAM2	DRAM2	DRAM2	DRAM2	DCPMM	-	-	-	-	-	-
Mixed Memory Mode	DCPMM	DRAM3	DRAM3	DRAM3	DRAM3	DCPMM	-	-	-	-	-	-
App Direct Mode	DCPMM	DRAM1	DRAM1	DRAM1	DRAM1	DCPMM	DCPMM	DRAM1	DRAM1	DRAM1	DRAM1	DCPMM
Memory Mode	DCPMM	DRAM2	DRAM2	DRAM2	DRAM2	DCPMM	DCPMM	DRAM2	DRAM2	DRAM2	DRAM2	DCPMM
Mixed Memory Mode	DCPMM	DRAM3	DRAM3	DRAM3	DRAM3	DCPMM	DCPMM	DRAM3	DRAM3	DRAM3	DRAM3	DCPMM

NOTE



DIMM Type	RDIMM	3DS RDIMM	LRDIMM	3DS LRDIMM	Capacity
DRAM1	✓	✓	✓	✓	Any Capacity
DRAM2	✓	✓	✓	✓	≥32GB
DRAM3	✓	✓	✓		Any Capacity
DCPMM	Any Capacity (Uniformly for all channels for system configuration)				

NOTE



- Please abide to the DCPMM population rules listed below for your system to function accordingly.
- There is only a maximum of 1 DCPMM in each channel.
 - Populate DCPMM DIMM on IMC0 before IMC1.

2.2.3 DIMM Installation

Step 1 Unlock the DIMM socket by pressing the retaining clips outward.



Step 2 Insert the memory module into the slot. Make sure that the DIMM notch is accurately positioned.

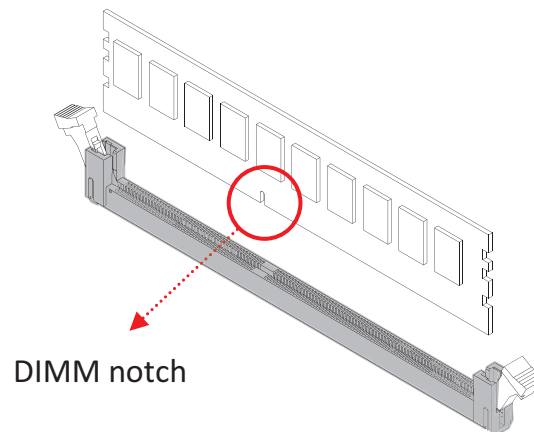

Step 3 Close the retaining clips to complete installation.

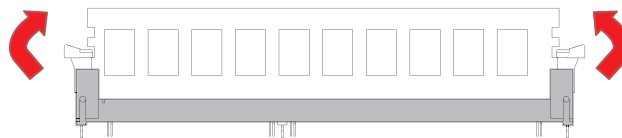

This information is provided for professional technicians only.

2.3 Top Cover

- ① Press the release buttons on both sides of the chassis to release the top cover.
- ② Slide the top cover towards the rear end of the system barebone.
- ③ Lift the cover upward to remove.

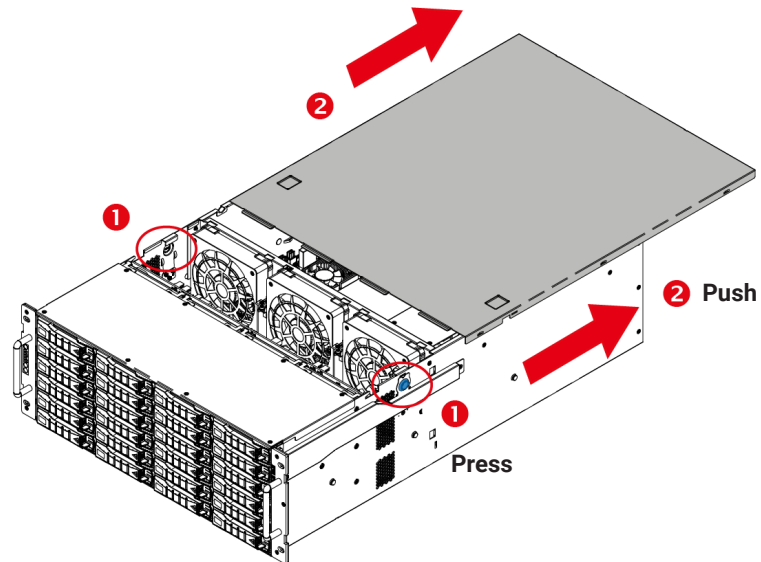

This information is provided for professional technicians only.

2.4 Power Supply Unit

2.4.1 Replacing the Power Supply Unit

- ① Press the ejector to release the power supply unit.
- ② Pull the handle to remove the module out of the chassis.
- ③ Push the new power supply unit into the chassis. Ensure that the module is robustly hooked into the cage.

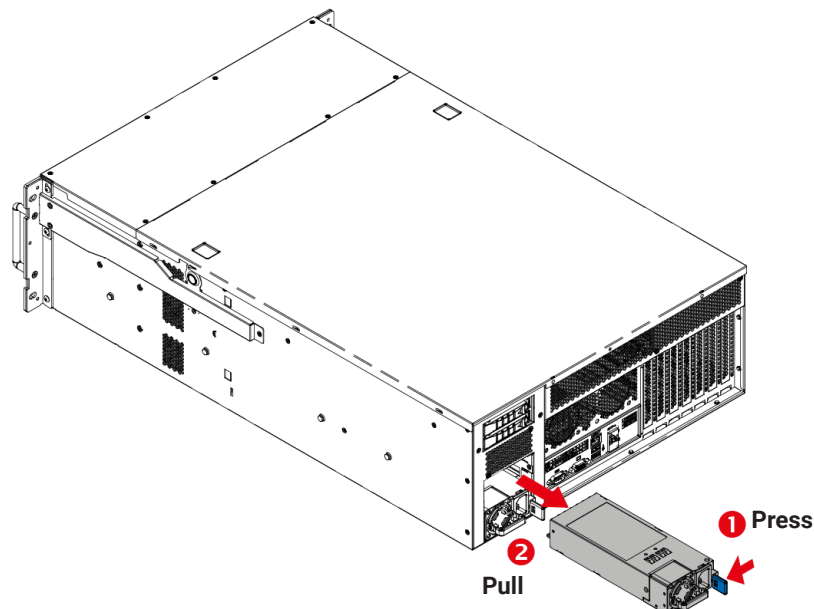

2.4.2 LED

Indicator Color	Behavior
Green	Output on and Ok.
Green (blinking, 1Hz)	Only 12Vsb (PS off) or PSU is in cold redundant state.
Amber	Power supply critical event causing a shutdown; AC cord unplugged or AC power lost, failure, OCP, OVP, fan fail.
Amber (blinking, 1Hz)	Power supply warning events where the power supply continues to operate high temp, high power, high current, slot fan.



This information is provided for professional technicians only.

2.5 Fan

- ① Initiate the removal of the fan by unplugging the cables and connectors from the fan.
- ② Extract the fan by carefully dislodging the rubber connectors on the fan from the securing bracket.
- ③ Insert the new fan into the chassis by verifying the alignment of the rubber connectors and bracket.

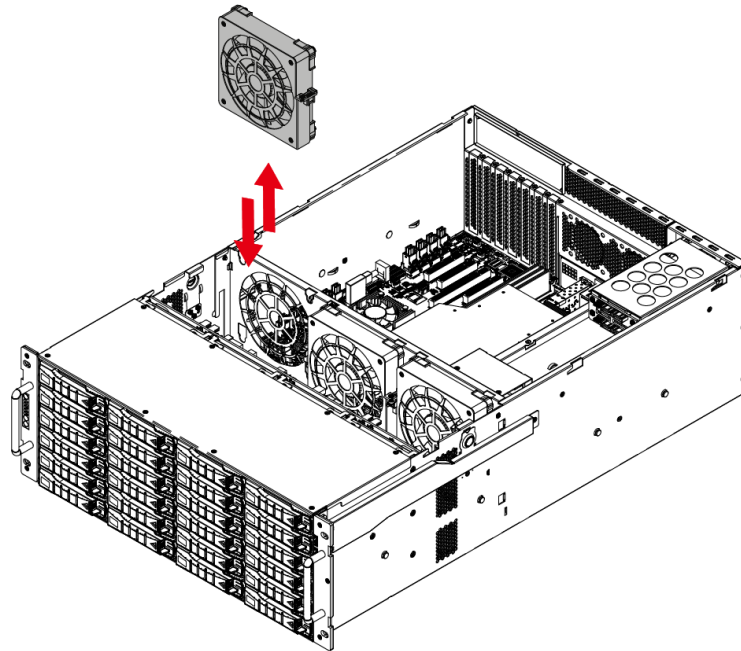

NOTE



The fan should be blowing toward the rear end of the chassis. If one of the fans is facing the wrong direction. Please remove the fan and reinstall so that it is facing the correct direction.



This information is provided for professional technicians only.

2.6 Hard Disk Drive

2.6.1 Hard Disk Drive: 3.5-inch

- ① Press the release button the tray lever to loosen the lever.
- ② Pull the tray lever outward completely.
- ③ Pull the tray out of the system.

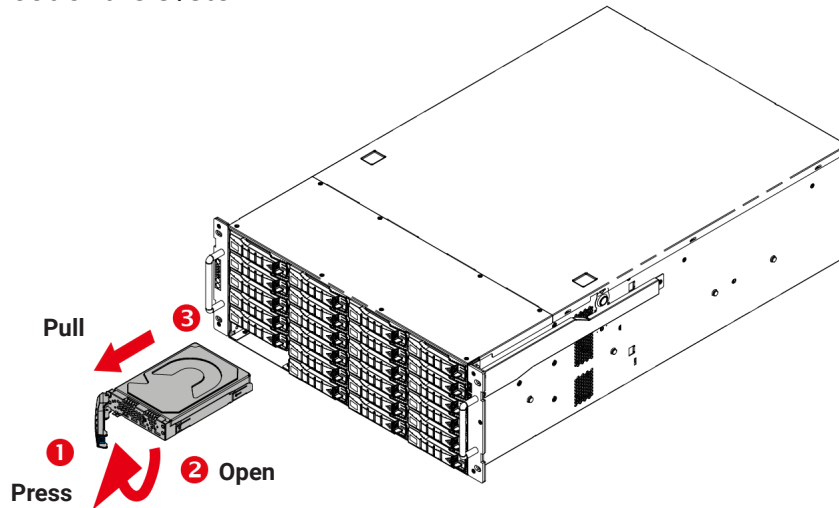

- ④ Insert the hard disk drive into the tray. Ensure that the dimples on the tray match the hard disk drive. For additional assurance, fasten the screws x 2 on the drive tray to secure the hard disk drive.screws.

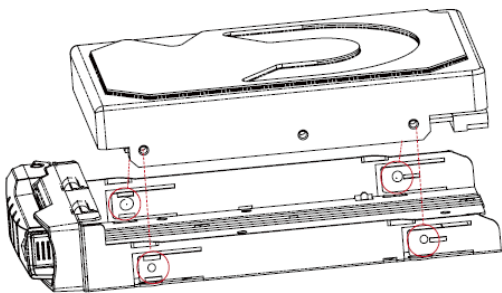

3.5" HDD dimple location

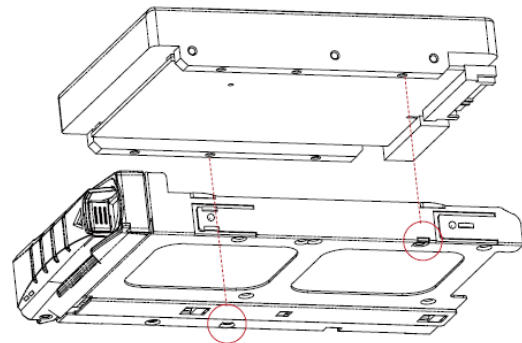

3.5" HDD screw location



This information is provided for professional technicians only.

2.6.2 Hard Disk Drive: 2.5-inch

- ① Press the release button the tray lever to loosen the lever.
- ② Pull the tray lever outward completely.
- ③ Pull the tray out of the system.

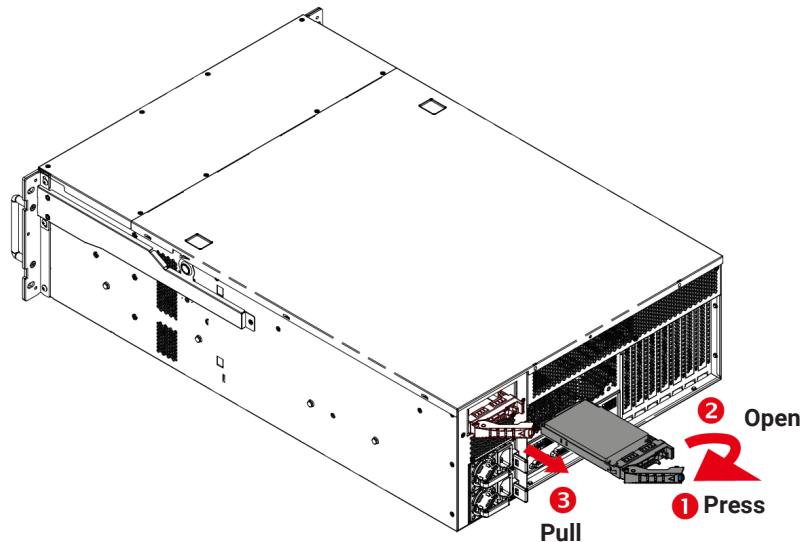

- ④ Insert the hard disk drive into the tray. Ensure that the dimples on the tray match the hard disk drive. For additional assurance, fasten the screws x 2 on the drive tray to secure the hard disk drive.

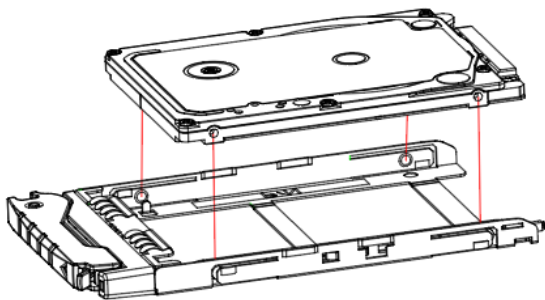

2.5" HDD dimple location

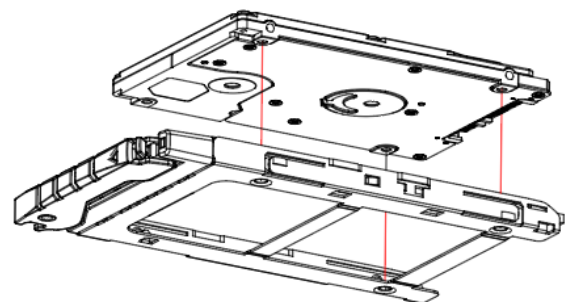

2.5" HDD screw location



This information is provided for professional technicians only.

2.6.3 LED

Item	Color	Behavior	Description
HDD Activity	Blue	On	HDD is present.
	Blue	Blinking	HDD activity is detected or have located HDD (slow).
	Off		HDD is not connected or the system power is Off.
HDD Fault/Status		Boot loader mode	No control bit is set or set by any of the following bits: 1. RQST OK 2. RQST RSVD DEVICE 3. RQST HOT SPARE 4. RQST ACTIVE 5. DO NOT REMOVE 6. RQST IDENT 7. DEVICE OFF
	Red	Blinking	Set by any of the following bits: 1. RQST CONS CHECK 2. RQST IN CRIT ARRAY 3. RQST IN FAILED ARRAY 4. RQST REBUILD/REMAP 5. RQST R/R ABORT 6. RQST INSERT 7. RQST REMOVE 8. PRDFAIL
	Red	On	Set by any of the following bits: 1. RQST MISSING 2. RQST FAULT

2.6.4 Drive Slot Map

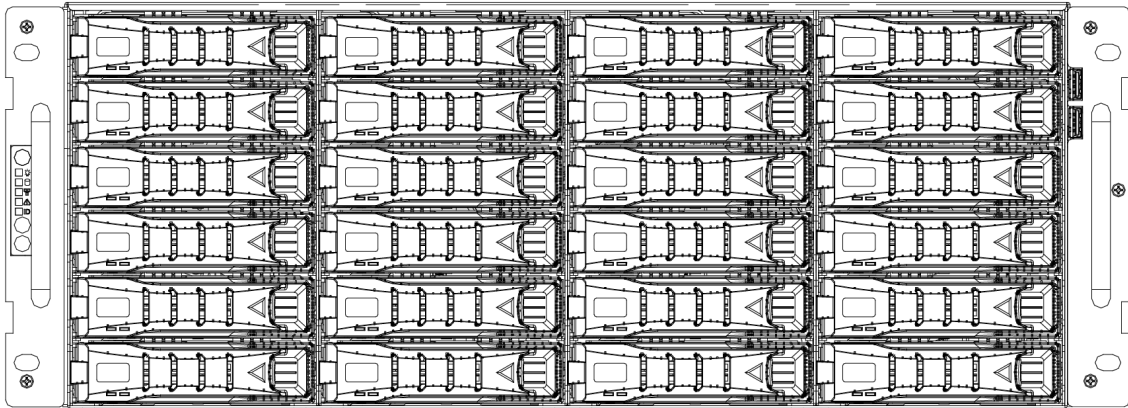

HBA card			
0	1	2	3
4	5	6	7
8	9	10	11
12	13	14	15
16	17	18	19
20	21	22	23

MegaRAID card			
1	2	3	4
5	6	7	8
9	10	11	12
13	14	15	16
17	18	19	20
21	22	23	24

2.7 Slide Rail

NOTE



This sections provides a basic instruction for mounting the slide rail onto the system. Tool-less rails vary per order. The rail in this manual may not exactly match the rail for your system. Please refer to the specifications or quick installation guide that came with your purchased product.

CAUTION



The rack may tilt and fall due to incorrect installation or placed on uneven grounds. The rack must be placed in a flat surface before you begin to slide the system barebone in for servicing.



This information is provided for professional technicians only.

- ① Pull the inner rail out of the slide rail until it clicks.
- ② Detach the inner rail completely from the slide rail by pulling the white tab forward.

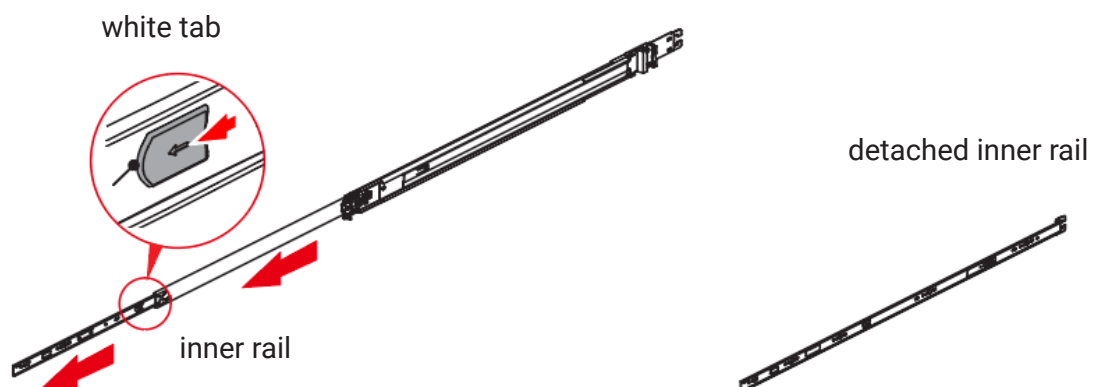

- ③ After the inner rail is dislodged, adjust the middle rail back to its original position by pushing the tab on the middle rail.

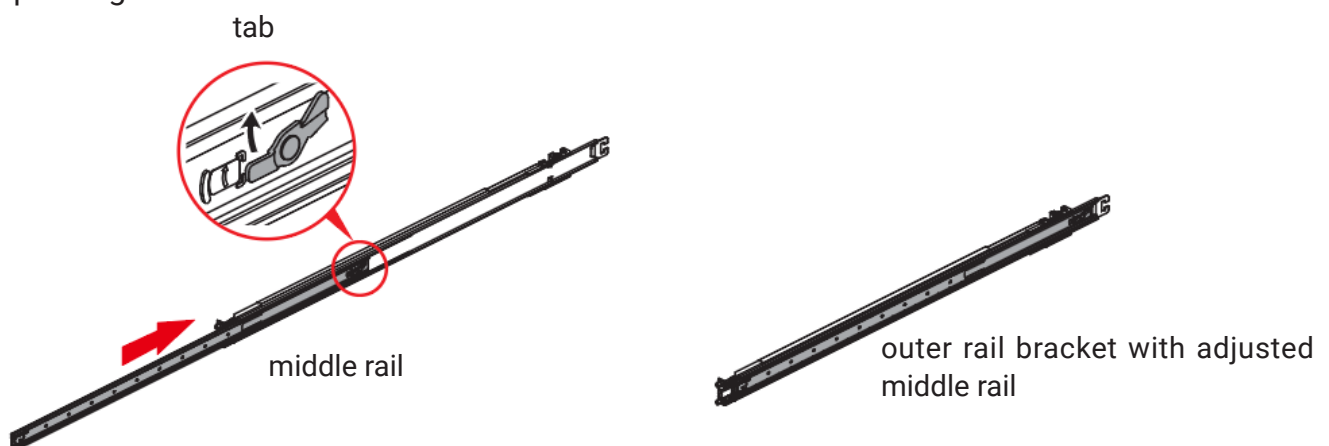

- ④ Install the inner rail onto the system barebone. Lock the keyholes and secure the screws.

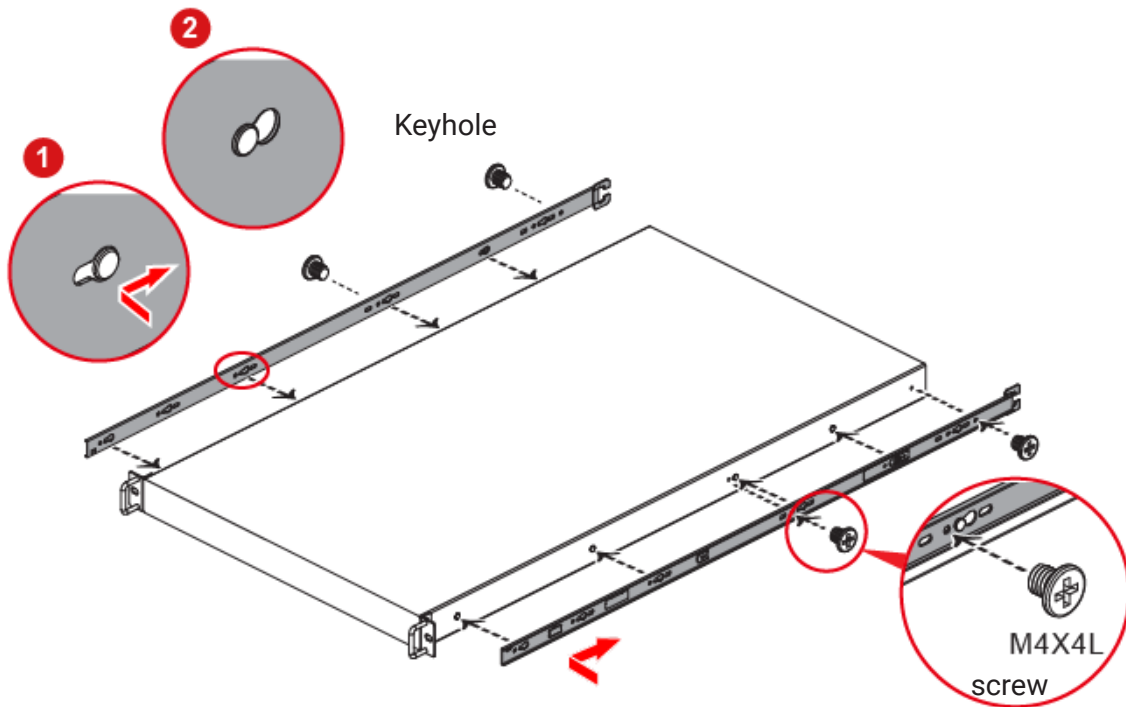

- ⑤ Continue installing the outer rail bracket to the mounting frame. Attach the outer rail assembling to the frame and press the bracket to fix the rail onto the frame. Repeat to fully mount the bracket assembly.

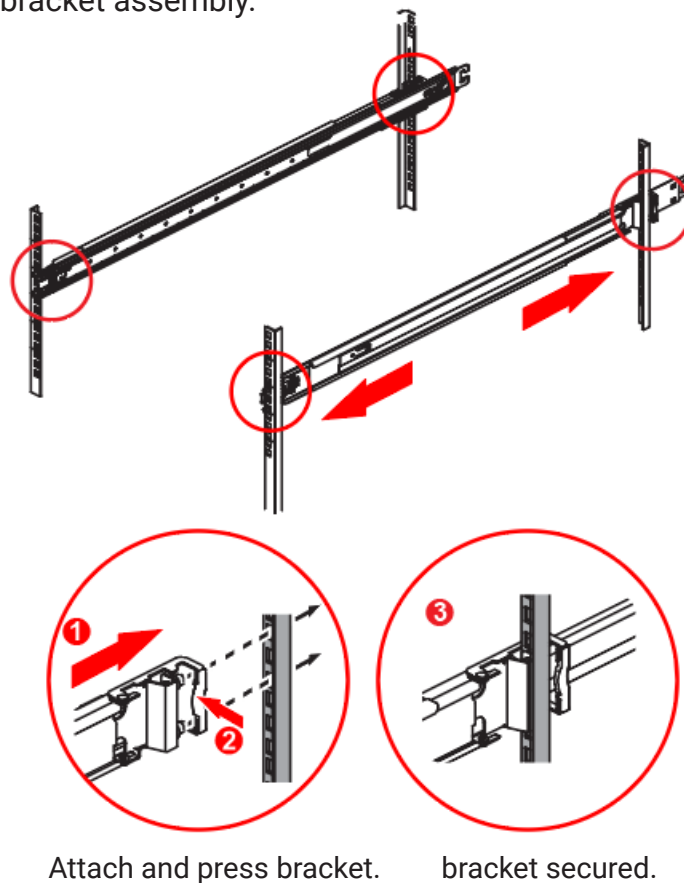

- ⑥ Pull out the middle channel until the ball bearing retainer is locked forward.

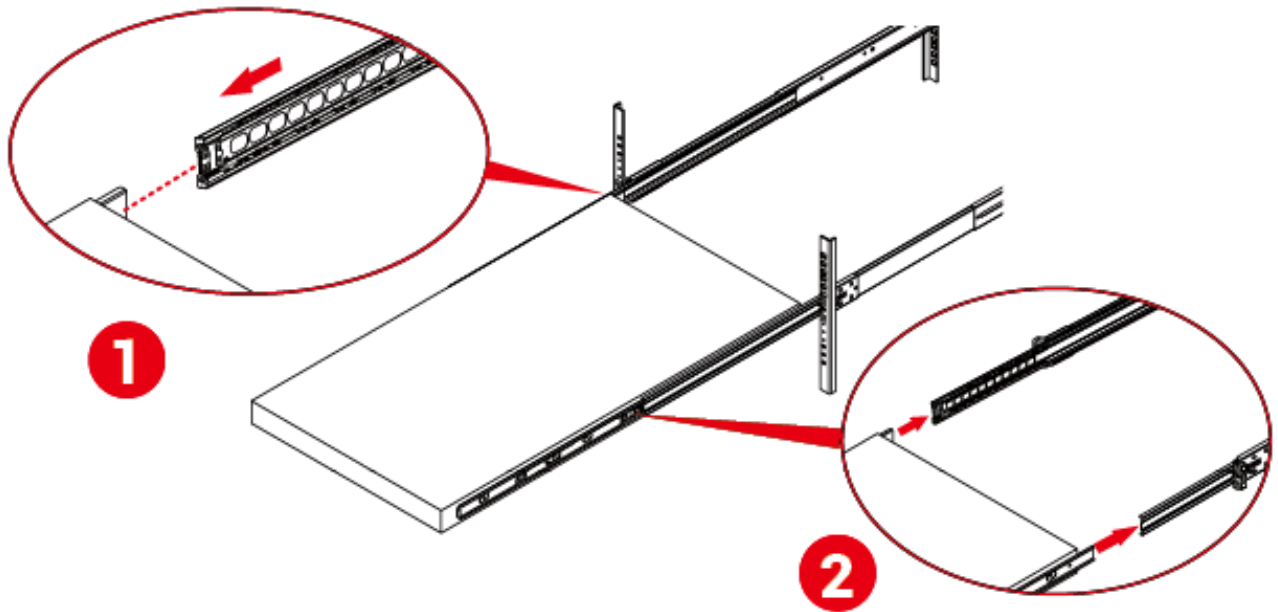

CAUTION
Verify ball bearing retainer is locked forward.

- ⑦ Slide the release tab and push barebone into rack. Make sure the barebone is completely installed onto the rack.

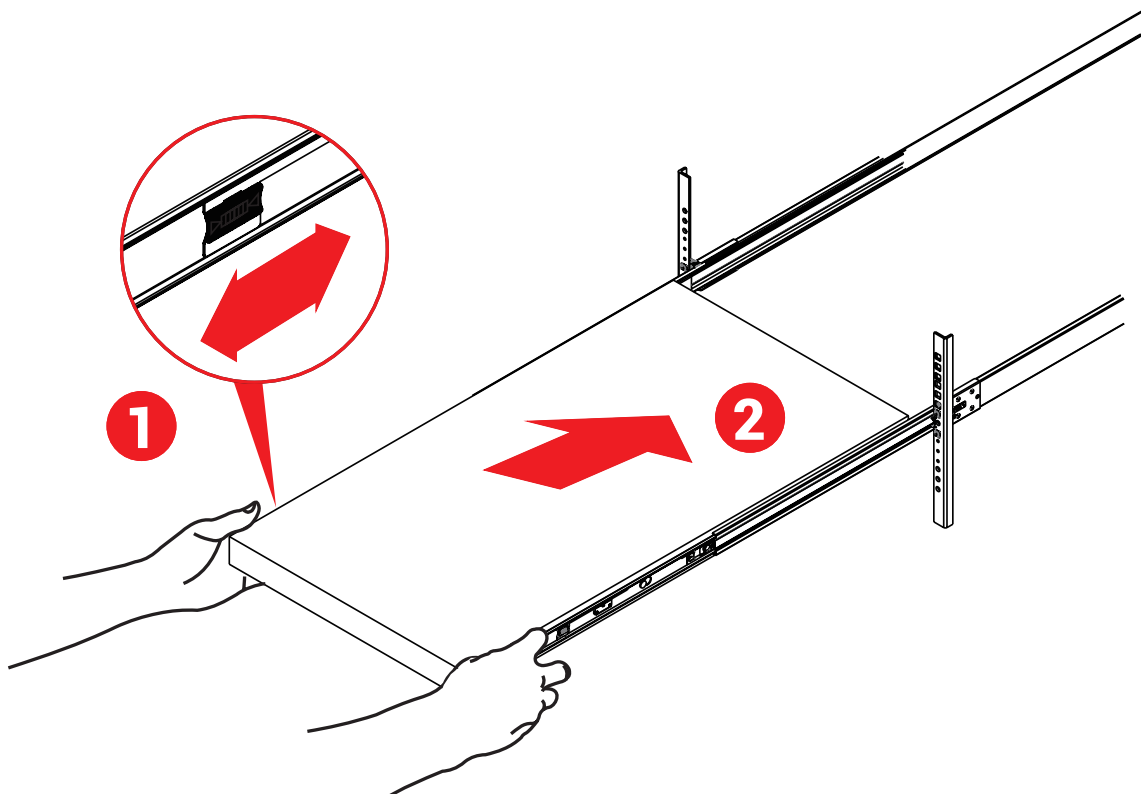

Chapter 3. Hardware Settings

This section describes the jumpers, internal connectors and internal LEDs settings.

3.1 Motherboard

3.1.1 Block Diagram

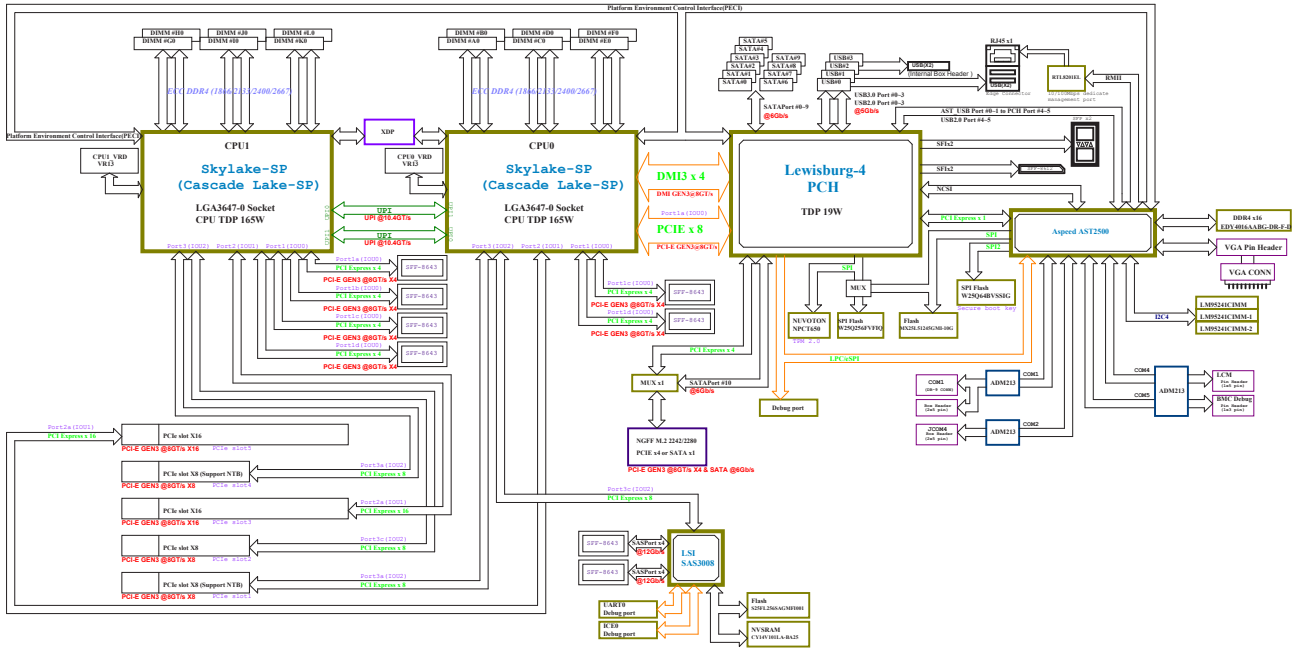

3.1.2 Content List

Connector/Jumper/Header		Location	Connector/Jumper/Header		Location
1a 1b 1c	Power Supply Connector	JPWR1, JPWR3, JPWR4	27	Front I/O USB Header	JUSB_INT
2	Power Supply Connector	JPWR2	28	SSI Front Panel Header	JFRNT_SSI
3a 3b 3c	External Thermal Sensor	J2, J13, J24	29	NGFF Connector	JNGFF
4a 4b 4c	CPU Fan Header PCH Fan Header	J1 & J22 J21	30	Internal 10GbE (Reserved)	J7
5a 5b 5c 5d 5e 5f	Fan Header–	J15, J16, J17, J23, J18, J14	31	SPI ROM Socket	JSPI_BIOS
6	SAS IOC Activity LED Header	J19	32	ESPI Header	JESPI
7	SAS IOC Error LED Header	J25	33	Debug Port Header	JLPC_DP
8	PMBUS Header	JPMBUS	34	PCIe Hot-Plug SMB Header	JPCIE_HP
9	SAS IOC UART Header	J20	35a 35b 35c	PCIe Hot-Plug Front Panel Header	J4, J5, J6
10	SFF-8643 Connector (PCIE)	CN1, CN2, CN3, CN4, CN5, CN6	36	ME Force Recovery Mode Jumper	J3
11	SFF-8643 Connector (SAS)	CN7, CN8	37	BMC Debug Port Select Jumper	J27
12	Battery Socket	JBAT	38a 38b	Front COM Header	JCOM1 JCOM4
13a 13b	Serial ATA	SATA4 SATA5	39	VROC KEY Header	JRAID_KEY
14a 14b	SATA4 & SATA5 Pin-7 Power Header	J10 J11	40	LCM Header	JLCM
15	PCH SSGPIO Header	JSSGPIO	41	10GbE Carrier Board Header (Reserved)	J28
16	Clear CMOS Jumper	JCMOS	42	BMC Debug Port Header	JBMC_DP
17	PCH GPIO Header	JPCH_GPIO	43	BMC Reset Jumper	JBMC_RST
18	BIOS Recovery Mode Jumper	J9	44	BMC I2C1 Header	JBMC_I2C1
19	Flash Descriptor Security override Jumper	J8	45	BMC GPIO Header	JBMC_GPIO
20	NTB	JNTB	46	Intruder	JINTRUDER
21	Speaker	JSPKR	47	BMC Buzzer	JBUZZER
22	System PG Lock	JPG_LOCK	48	BMC I2C10 Header	JBMC_I2C10
23	SATA-DOM Power Connector	JDOM_PWR	49	BMC Disable Jumper	JBMC_DIS
24	SAS IOC ICE Header	J12	50	PCH SGPIO Header	JSGPIO
25a 25b	Mini SAS Connector	SATA0_3 SATA6_9	51	Front VGA Header	JVGA_INT
26	No Reboot(Watch Dog) Jumper	J26	52	Power Supply Connector	JPWR5

3.1.3 Placement

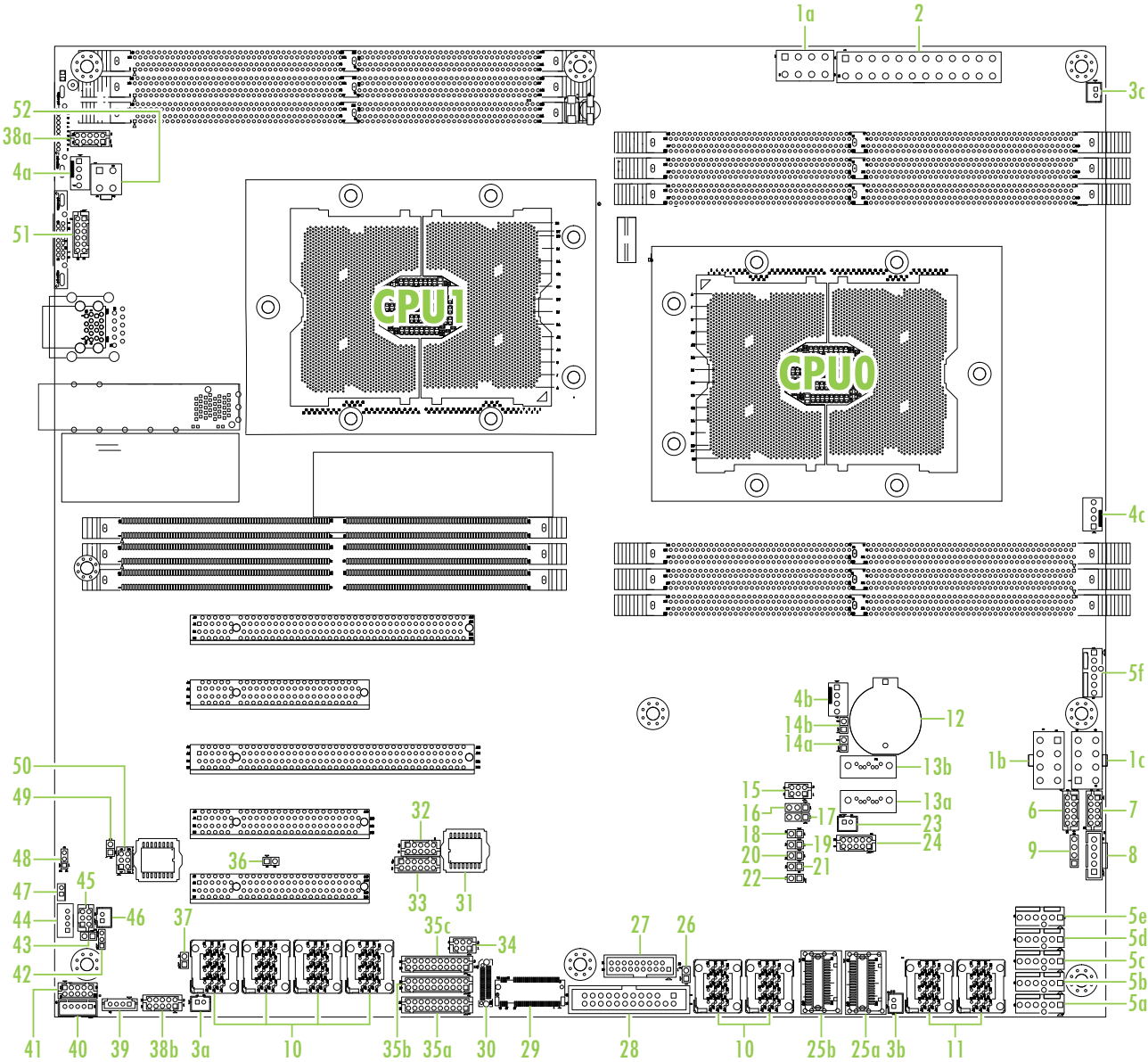

3.1.4 Connector

1a ~ 1c Power Connector (JPWR1, JPWR3 & JPWR4)



GND	1	5	+12V
GND	2	6	+12V
GND	3	7	+12V
GND	4	8	+12V

2 Power Connector (JPWR2)

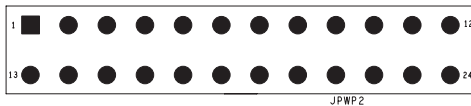

+3.3V	1	13	+3.3V
+3.3V	2	14	+12V
GND	3	15	GND
+5V	4	16	PS_ON#
GND	5	17	GND
+5V	6	18	GND
GND	7	19	GND
POWER_OK	8	20	NC
+5V_AUX	9	21	+5V
+12V	10	22	+5V
+12V	11	23	+5V
+3.3V	12	24	GND

4a 4b 4c Fan Header (J1, J21 & J22)

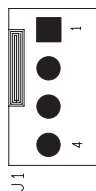

1	PWM
2	TACH
3	+12V
4	GND

5 Fan Header (J14, J15, J16, J17, J18, J23)

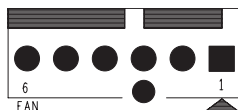

1	FAULT
2	PRSNT_N
3	PWM
4	+12V
5	+12V
6	GND

6 SAS IOC Activity LED Header (J19)

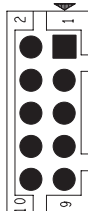

+3.3V	1	2	GND
SAS_LED_GPIO12	3	4	SAS_LED_GPIO8
SAS_LED_GPIO13	5	6	SAS_LED_GPIO9
SAS_LED_GPIO14	7	8	SAS_LED_GPIO10
SAS_LED_GPIO15	9	10	SAS_LED_GPIO11

7 SAS IOC Error LED Header (J25)

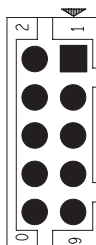

+3.3V	1	2	GND
SAS_LED_GPIO20	3	4	SAS_LED_GPIO16
SAS_LED_GPIO21	5	6	SAS_LED_GPIO17
SAS_LED_GPIO22	7	8	SAS_LED_GPIO18
SAS_LED_GPIO23	9	10	SAS_LED_GPIO19

8 PMBus Header (JPMBUS)

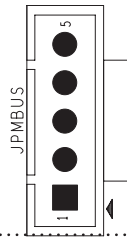

1	SMB_PMBUS_CLK
2	SMB_PMBUS_DATA
3	PMBUS_ALERT_N
4	GND
5	+3.3V

9 SAS IOC UART Header (J20)

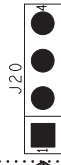

1	UART0_TX
2	GND
3	UART0_RX
4	SAS3008_1V8

15 PCH SSGPIO Header (JSSGPIO)

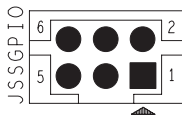

GND	1	2	PCH_SSDATAOUT0
PCH_SSDATAOUT1	3	4	PCH_SSLOAD
+3.3V	5	6	PCH_SSCLOCK

17 PCH GPIO Header (JPCH_GPIO)



1	PCH_GPP_C16
2	PCH_GPP_C17
3	GND

24 SAS IOC ICE Header (J12)

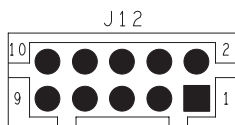

ICE0_TMS	1	2	ICE0_TRST_L
ICE0_TDO	3	4	ICE0_TCK
ICE0_TDI	5	6	SAS3008_1V8
NC	7	8	GND
SYS_HALT_L0	9	10	NC

27 Front I/O USB Header (JUSB_INT)

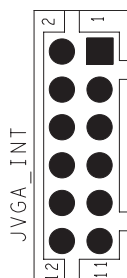

+5V_USB23	1	11	PCH_FP_USB2_P3
PCH_FP_USB3_RX_N2	2	12	PCH_FP_USB2_N3
PCH_FP_USB3_RX_P2	3	13	GND
GND	4	14	PCH_FP_USB3_TX_P3
PCH_FP_USB3_TX_N2	5	15	PCH_FP_USB3_TX_N3
PCH_FP_USB3_TX_P2	6	16	GND
GND	7	17	PCH_FP_USB3_RX_P3
PCH_FP_USB2_N2	8	18	PCH_FP_USB3_RX_N3
PCH_FP_USB2_P2	9	19	+5V_USB23
PCH_USB_OC#23	10	20	KEY (no pin)

28 SSI Front Panel Header (JFRNT_SSI)

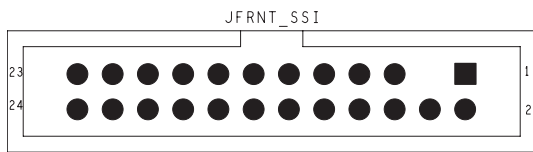

+3.3V	1	2	+3.3V_DUAL
KEY (no pin)	3	4	+5V_AUX
PWR_LED#	5	6	UIDLED_OUT#
+3.3V	7	8	SYS_HEALTH#2
HD_LED#	9	10	SYS_HEALTH#1
SW_PWR_BTN#	11	12	LAN1_LINK_UP
GND	13	14	LAN1_TRAFFIC
SW_RST_BTN#	15	16	I2C8SDA
GND	17	18	I2C8SCL
UID_SW_IN#	19	20	INTRUDER#
+3.3V_DUAL	21	22	LAN2_LINK_UP
FP_NMI_BTN	23	24	LAN2_TRAFFIC

32 EPSI Header (JEPSI)

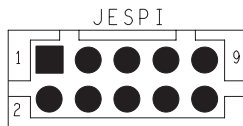

+5V_AUX	1	2	PGPPA_PCH
PCH_SMI_N	3	4	SMB_HOST_3V3_DAT
PCH_LPC_CLKRUN_N	5	6	SMB_HOST_3V3_CLK
PCH_PME_N	7	8	PCH_ESPI_RST_N
GND	9	10	PCH_ESPI_ALENT1_N

33 Debug Port Header (JLPC_DP)

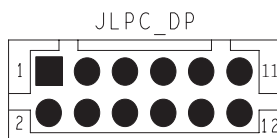

GND	1	2	CLK_24M_DP80
PCH_LDRQ0_N	3	4	PCH_LFRAME_N
AST_SERIRQ	5	6	RST_PLTRST_N
PCH_LPC_LAD2	7	8	PCH_LPC_LAD3
PCH_LPC_LAD1	9	10	+3.3V
GND	11	12	PCH_LPC_LAD0

34 PCIe Hot-Plug SMB Header (JPCIE_HP)

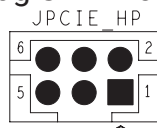

CPU0_HP_I2C_CLK	1	2	CPU1_HP_I2C_CLK
CPU10_HP_I2C_DAT	3	4	CPU1_HP_I2C_DAT
+3.3V	5	6	GND

35 PCIe Hot-Plug Front Panel Header (J4, J5, & J6)

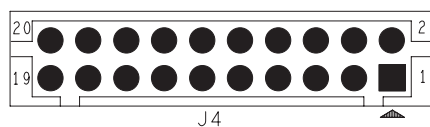

+3.3V	1	2	+3.3V
PRSENT-1	3	4	PRSENT-2
PWR FAULT-1	5	6	PWR FAULT-2
PWR ENABLE-1	7	8	PWR ENABLE-2
ATTEN BUTTON-1	9	10	ATTEN BUTTON-2
MRL/EMIS-1	11	12	MRL/EMIS-2
EMIL-1	13	14	EMIL-2
ATTEN LED-1	15	16	ATTEN LED-2
PWR LED-1	17	18	PWR LED-2
GND	19	20	GND

38 Front COM Header (JCOM1 & JCOM4)

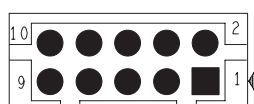

DSRB	1	2	DCDB
RTSB	3	4	RXDB
CTSB	5	6	TXDB
RIB	7	8	DTRB
NC	9	10	GND

39 VROC KEY Header (JRAID_KEY)

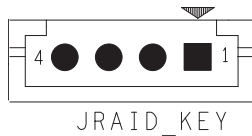

1	GND
2	+3.3V_DUAL
3	GND
4	PCH_GPP_C10

40 LCM Header (JLCM)

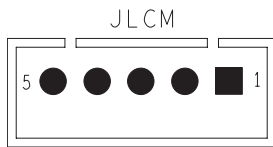

1	SW_PWR_BTN#
2	SW_RST_BTN#
3	TXDC
4	RXDC
5	GND

41 10GbE Carrier Board Header (J28)

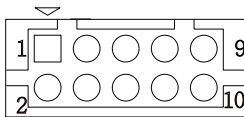

+3.3V_DUAL	1	2	+3.3V_DUAL
LAN_LED3_ACT	3	4	LAN_LED2_ACT
LAN_LED3_10G	5	6	LAN_LED2_10G
LAN_LED3_1G	7	8	LAN_LED2_1G
GND	9	10	GND

42 BMC Debug Port Header (JBMC_DP)



1	BMC_UART_TXD5
2	BMC_UART_RXD5
3	GND

44 BMC I2C1 header (JBMC_I2C1)

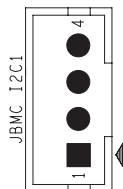

1	I2C1SDA
2	GND
3	I2C1SCL
4	NC

45 BMC GPIO Header (JBMC_GPIO)

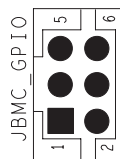

GND	1	2	EXTRST#
I2C9SDA	3	4	BMC_GPY1
I2C9SCL	5	6	BMC_GPY0

48 BMC I2C10 header (JBMC_I2C10)



1	GND
2	I2C10SDA
3	I2C10SCL

50 PCH SGPIO header (JSGPIO)

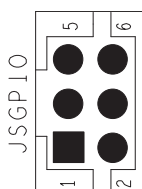

GND	1	2	PCH_SDATAOUT0
PCH_SDATAOUT1	3	4	PCH_SLOAD
+3.3V	5	6	PCH_SCLOCK

51 Front VGA Header (VGA_INT)

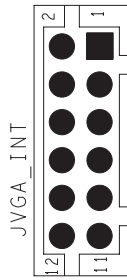

DVO_5V	1	2	GND
GND	3	4	DACROA
DDC_DATA0	5	6	GND
AVSYNCO	7	8	DACGOA
AHSYNCO	9	10	GND
DDC_CLKO	11	12	DACBOA

52 Power Connector (JPWR5)

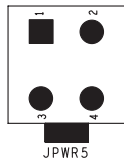

GND	1	3	+12V
GND	2	4	+12V

3.1.5 Jumper

14a SATA4 Pin-7 Power Header (J10)



J10	Setting	
Short	SATA4 pin-7 Power	
Open	Normal	Default

14b SATA5 Pin-7 Power Header (J11)



J11	Setting	
Short	SATA5 pin-7 Power	
Open	Normal	Default

NOTE



- If the SATA DOM power is supplied by the motherboard, please close the jumper.
- If the SATA DOM power is supplied by external power, please open the jumper.
- If the a SATA type hard drive is connected to the motherboard, please open the jumper.

SATA DOM Jumper



16 Clear CMOS Jumper (JCMOS)



JCMOS	Setting	
Pin1-2	Normal	Default
Pin2-3	Clear CMOS	

18 BIOS Recovery Mode Jumper (J9)

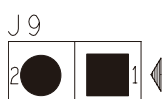

J9	Setting	
Short	BIOS Recovery Mode	
Open	Normal	Default

19 Flash Descriptor Security override Jumper (J8)



J8	Setting	
Short	Flash Security override	
Open	Normal	Default

20 NTB Jumper (JNTB)



JNTB	Setting	
Short	Downstream port	
Open	Upstream port	Default

22 System Power Good Lock (JPG_LOCK)



JPG_LOCK	Setting	
Short	Lock	
Open	Normal	Default

26 No Reboot(Watch Dog) Jumper (J26)



J26 (No Reboot)	Setting	
Short	Enable	
Open	Disable	Default

36 ME Force Recovery Mode Jumper (J3)



J3	Setting	
Short	ME Recovery Mode	
Open	Normal	Default

37 BMC Debug Port (J27)



J27	Setting	
Short	JCOM	
Open	JBMC_DP	Default

43 BMC Reset Jumper (JBMC_RST)

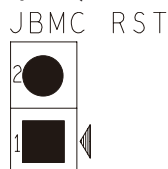

JBMC_RST	Setting	
Short	Reset BMC	
Open	Normal	Default

49 BMC ARM (JBMC_DIS)

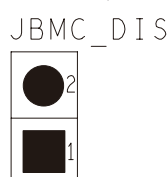

JBMC_DIS	Setting	
Short	Disable	
Open	Normal	Default

3.1.6 Internal LED

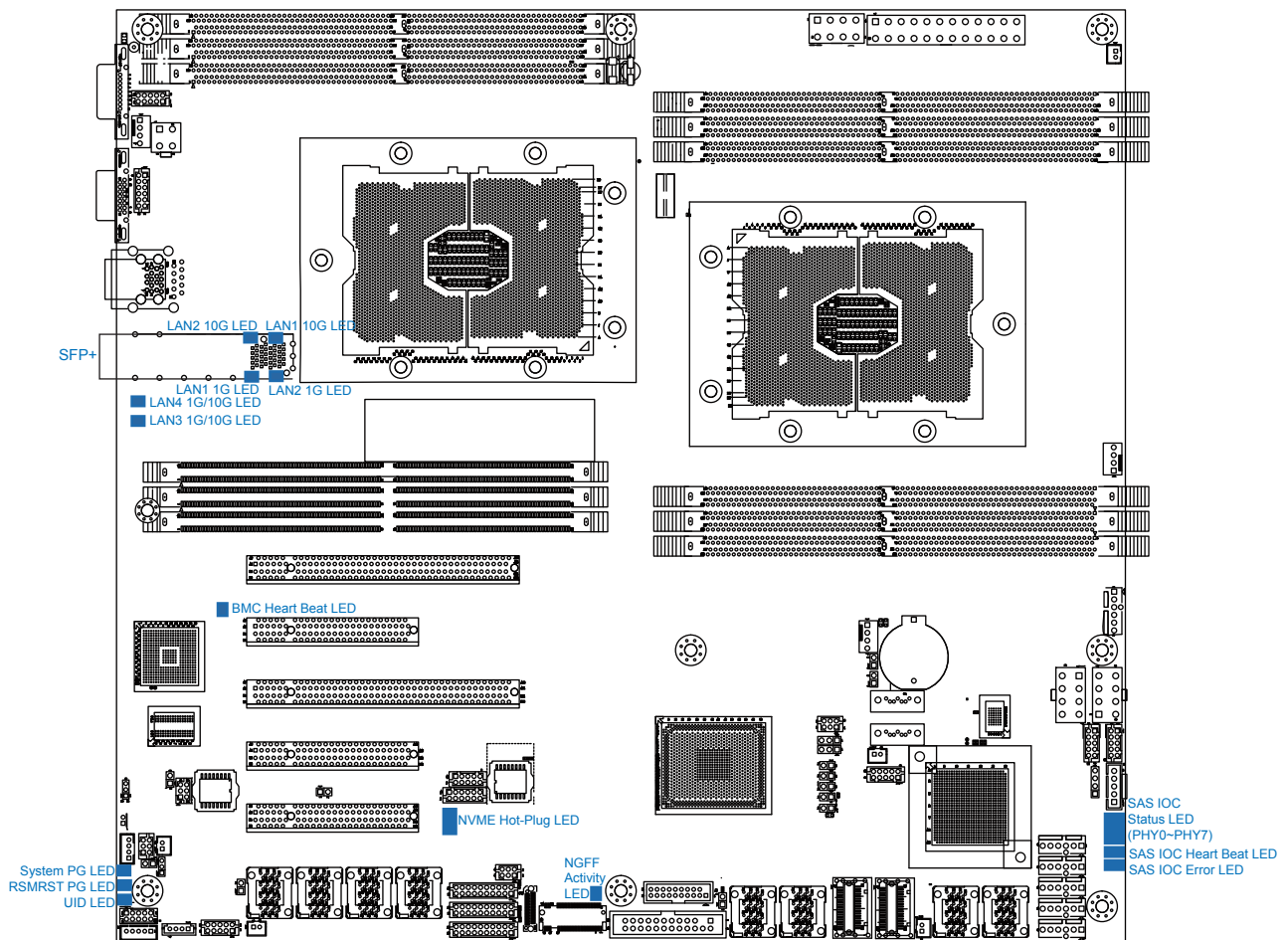

LED	Color	Behavior
Heart Beat	Green (Blinking) Off	BMC activity is detected. BMC is not active.
SYS PG LED	Green Off	System power is ready. System power is not ready.
RSMRST PG LED	Yellow Off	Resume Well Reset is ready. Resume Well Reset is not ready.
SAS IOC Status LED	Green(Blinking) Off	PHY0-7 activity is detected. PHY0-7 no activity is detected.
SAS IOC Heart Beat LED	Green(Blinking) Off	SAS IOC activity is detected. SAS IOC no activity is detected.
SAS IOC Error LED	Yellow Off	SAS IOC failure is detected. SAS IOC no failure is detected.
NIC 3 10G LED	Green (Blinking)	10G link activity is detected.
NIC 3 1G LED	Yellow (Blinking)	1G link activity is detected.
NIC 4 10G LED	Green (Blinking)	10G link activity is detected.
NIC 4 1G LED	Yellow (Blinking)	1G link activity is detected.
NGFF Activity LED	Blue(Blinking) OFF	NGFF activity is detected. NGFF activity is not detected.

3.1.7 Rear I/O Panel

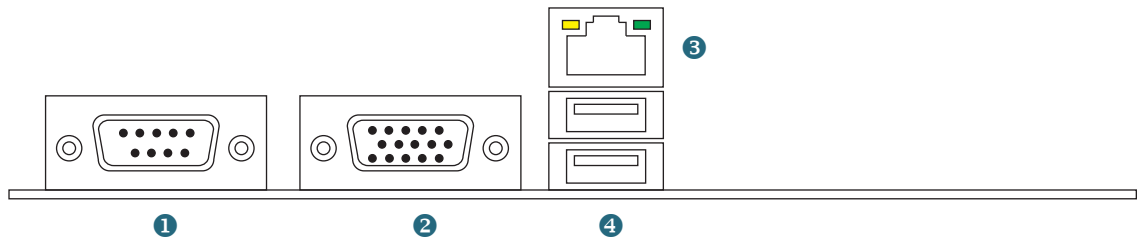

Item	Placement	Item	Placement
1	COM port	3	RJ45 port for BMC
2	VGA port	4	USB 2.0/3.0 Port *2

LAN LED

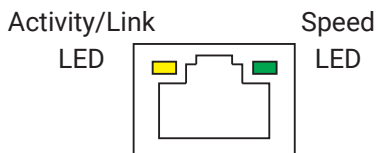

Item	Color	Behavior
Activity/Link LED	Off	No link.
	Yellow (blinking)	Data activity.
	On	Link.
Speed LED	Off	10M bps connection or no link.
	Off	100M bps connection.
	Green	1G bps connection.

3.2 HDD Backplane: 2 Bay

3.2.1 Connector Location

Top view

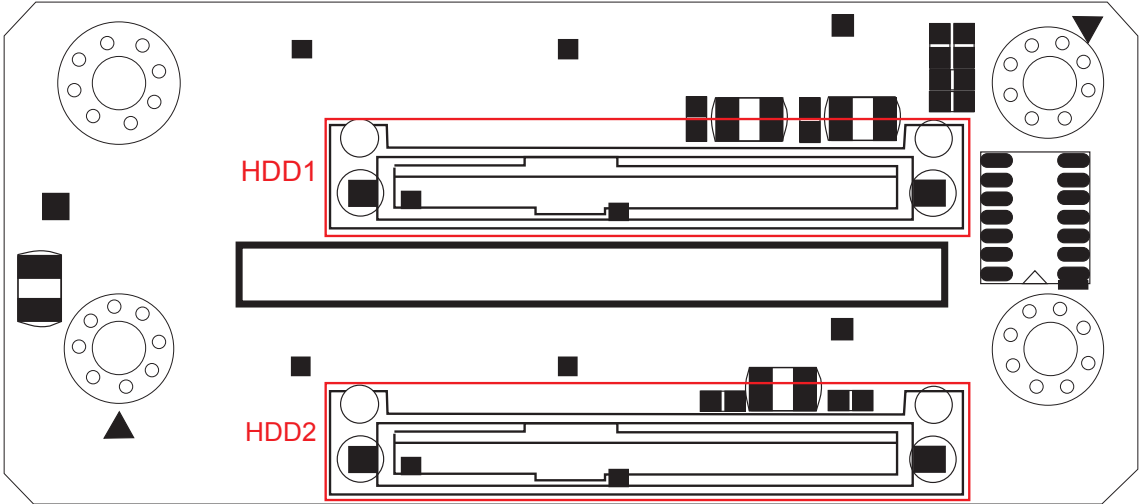

Backside view

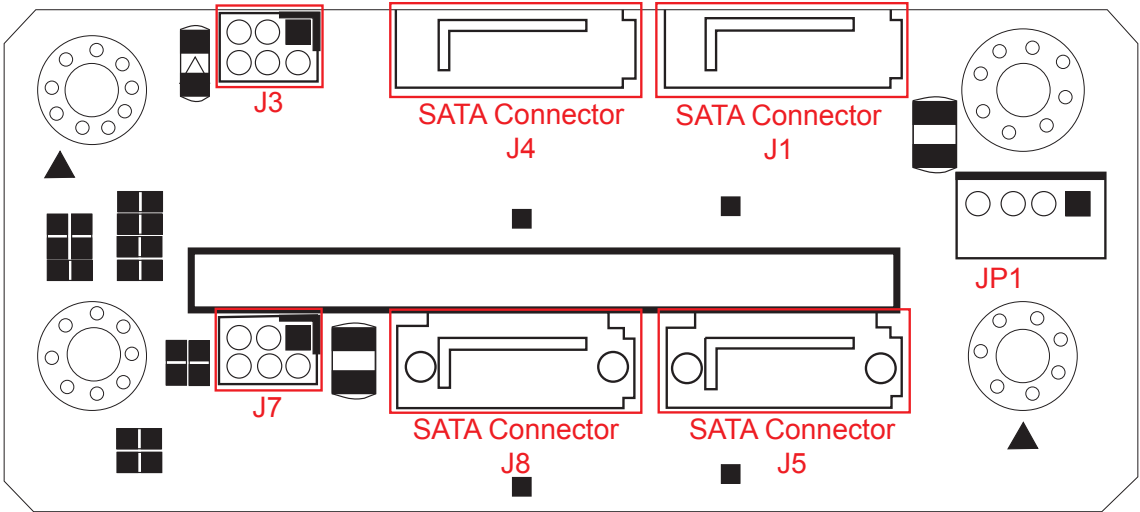

3.2.2 Connector

Power connector (JP1)

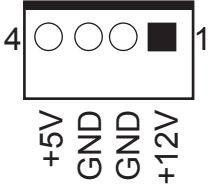

LED I/O Connector



	Pin	Description		Pin	Description
LED signal output	1	Fail LED-	From External input control	2	Fail LED0-
	3	4V3		4	GND
	5	ACC LED0-		6	ACC LED0-

3.3 HDD Backplane: 24 Bay

3.3.1 Placement

Top view

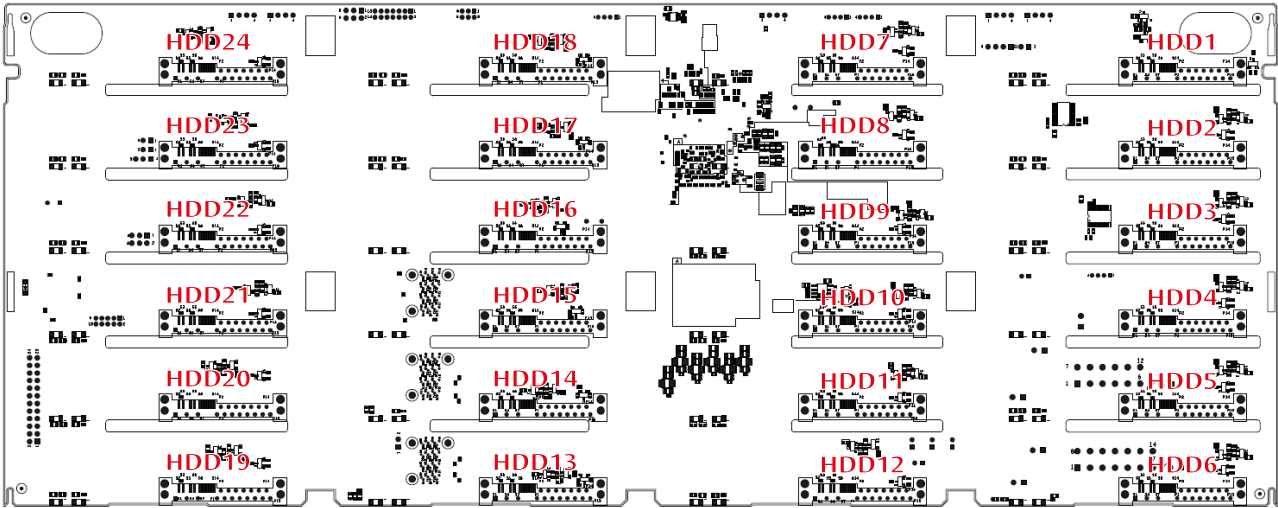

Backside view

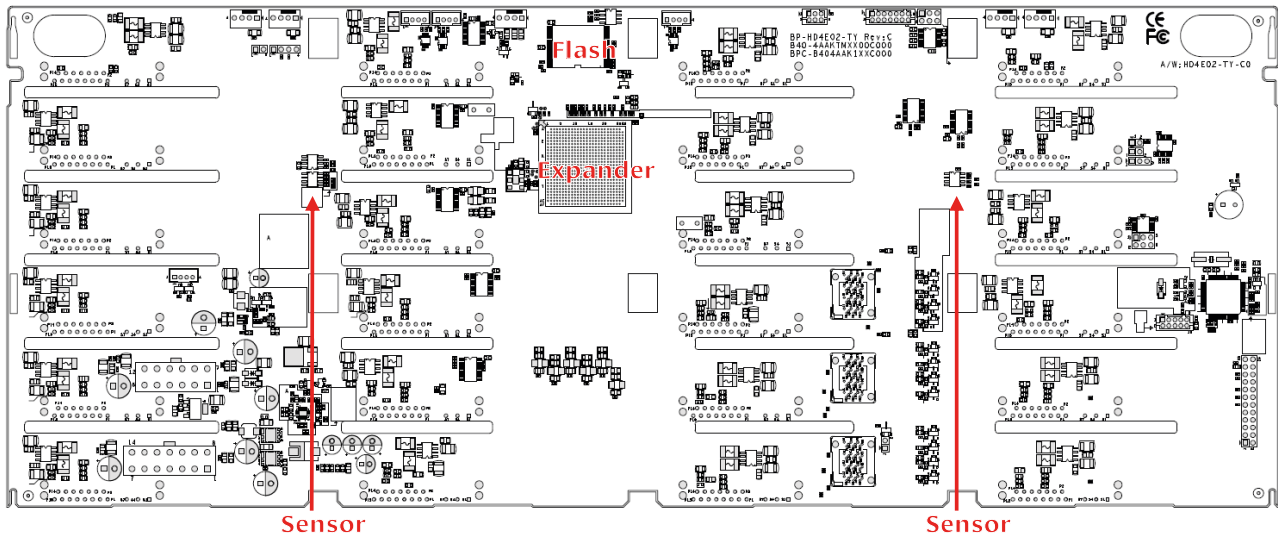

3.3.2 Connector Location

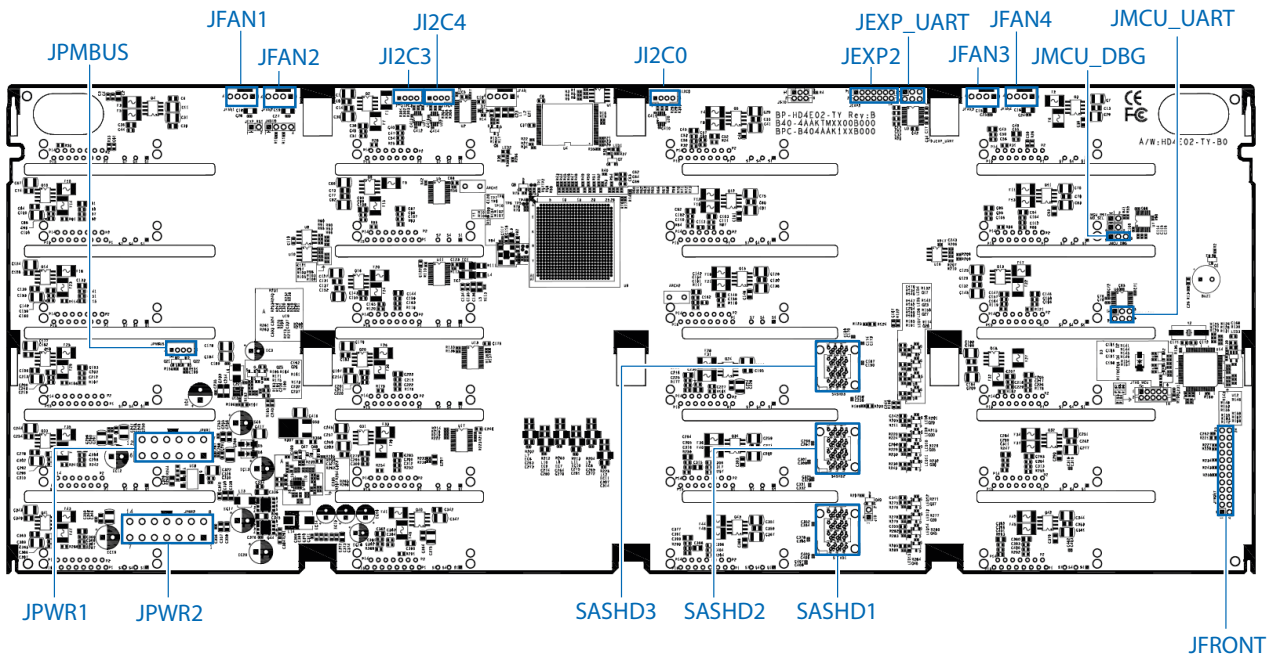

3.3.3 Connectors

Power Connector (JPWR1)

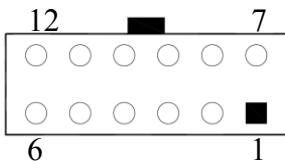

Pin	Description	Pin	Description
7	+12V	1	GND
8	+12V	2	GND
9	+3.3V	3	GND
10	+5V	4	MUTE_L
11	+5VSTBY	5	PSU_N1
12	PS_ON_L	6	GND

Power Connector (JPWR2)

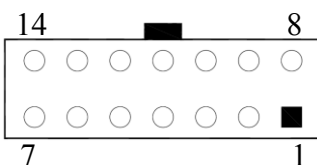

Pin	Description	Pin	Description
8	+12V	1	GND
9	+12V	2	GND
10	+12V	3	GND
11	+12V	4	GND
12	+5V	5	GND
13	+5V	6	GND
14	+5V	7	GND

PMBUS Connector (JPMBUS)

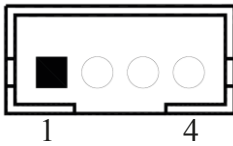

Pin	Description
1	GND
2	PMBUS_CLOCK
3	PMBUS_DATA
4	N/A

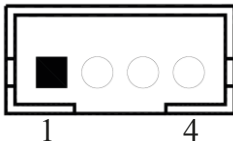
I²C Connector (JI2C0, JI2C3, JI2C4)

Pin	Description
1	GND
2	I2C_CLOCK
3	I2C_DATA
4	N/A

Fan Connector (JFAN1, JFAN2, JFAN3, JFAN4)

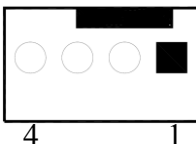

Pin	Description
1	GND
2	+12V
3	TACH
4	PWM

Console for Expander (JEXP_UART)

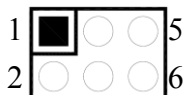

Pin	Description	Pin	Description
2	DEBUG_RXD	1	SMART_RXD
4	GND	3	GND
6	DEBUG_TXD	5	SMART_TXD

Remote Power Control (JMCU_UART)

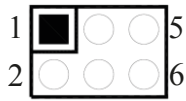

Pin	Description	Pin	Description
2	DOWN_RXD	1	UP_RXD
4	GND	3	GND
6	DOWN_TXD	5	UP_TXD

Console for MCU (JMCU_DBG)



Pin	Description
1	MCU_RXD
2	GND
3	MCU_TXD

2.54mm Header for Front I/O (JFRONT)

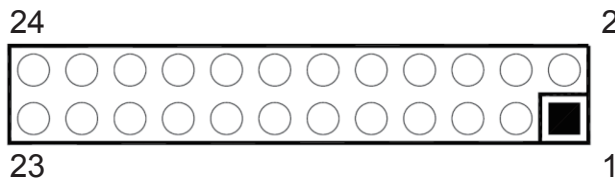

- Fan number select

Pin [5,6]	Pin [3,4]	Pin [1,2]	Fan no. support	Active Fan Locate
Close	Close	Close	No Fan	
Close	Close	Open	One Fan	JFAN1
Close	Open	Close	Two Fan	JFAN1 and JFAN2
Close	Open	Open	Three Fan	JFAN1,JFAN2 and JFAN3
Open	Close	Close	Four Fan	JFAN1,JFAN2,JFAN3 and JFAN4

- AT Mode Setting

Pin	Description	Remark
9	GND	
10	AT_SEL_N	Active Low

- Mute SW

Pin	Description	Remark
17	GND	
18	MUTE Input(-)	Active Low

3.3.4 Jumper

Backside view

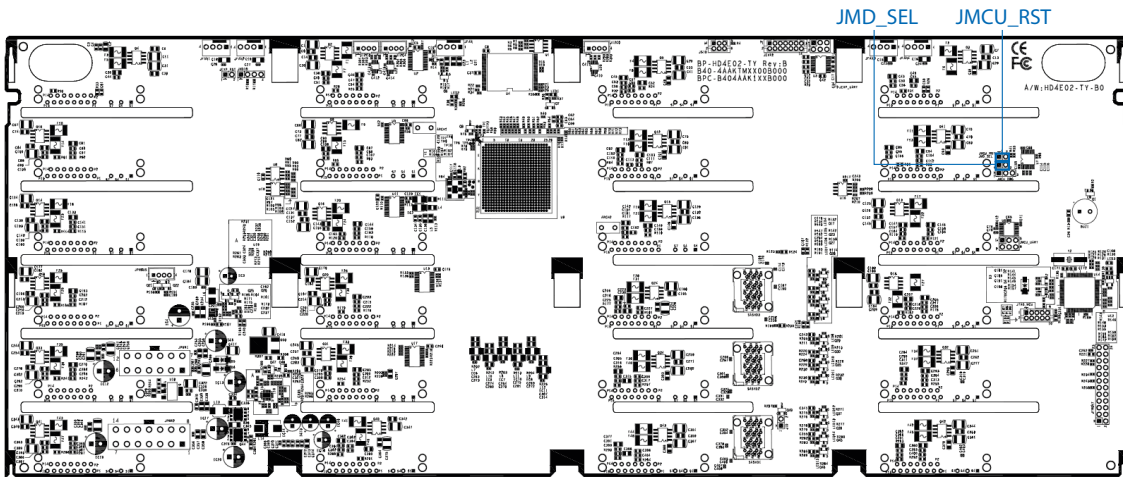

JMCU_RST	Open	Normal, default
	Close	Reset MCU
JMD_SEL	Open	Normal, default
	Close	Boot loader mode

3.3.5 Internal LED

Backside view

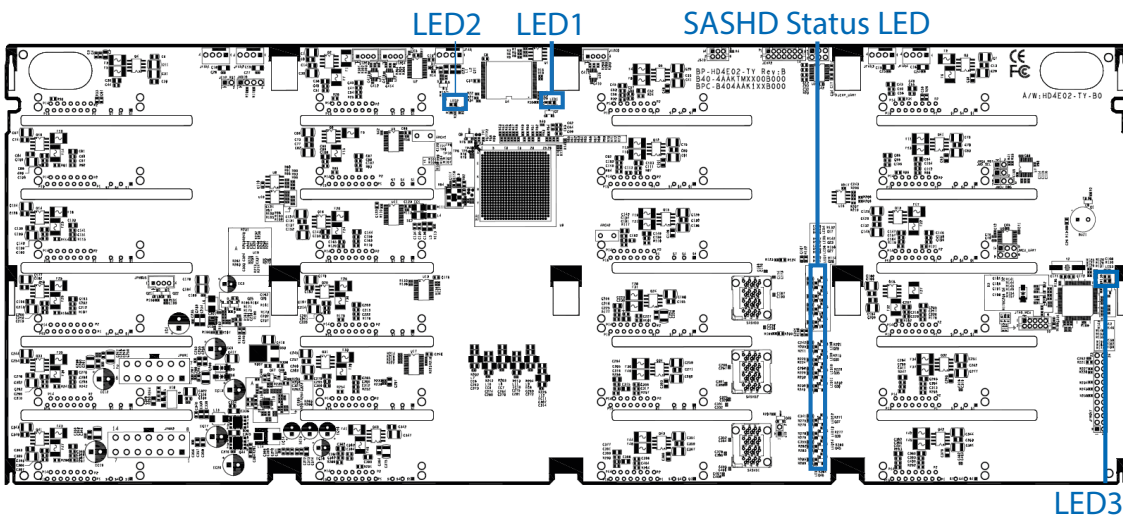

SAS HD Link Status	Blue	On	Link up
	Blue	Blinking	Activity detected
	Off		Link down
Expander Blinking (LED2)	Blue	Blinking	Expander alive, 0.0833Hz (12 seconds per cycle)
Expander Heart Beat (LED1)	Blue	Blinking	Expander FW running
MCU Status (LED3)	Yellow	On	MCU alive
	Yellow	Off	Boot loader mode

3.3.6 Cable Routing

Top view

Connects to SATA/SAS storage device

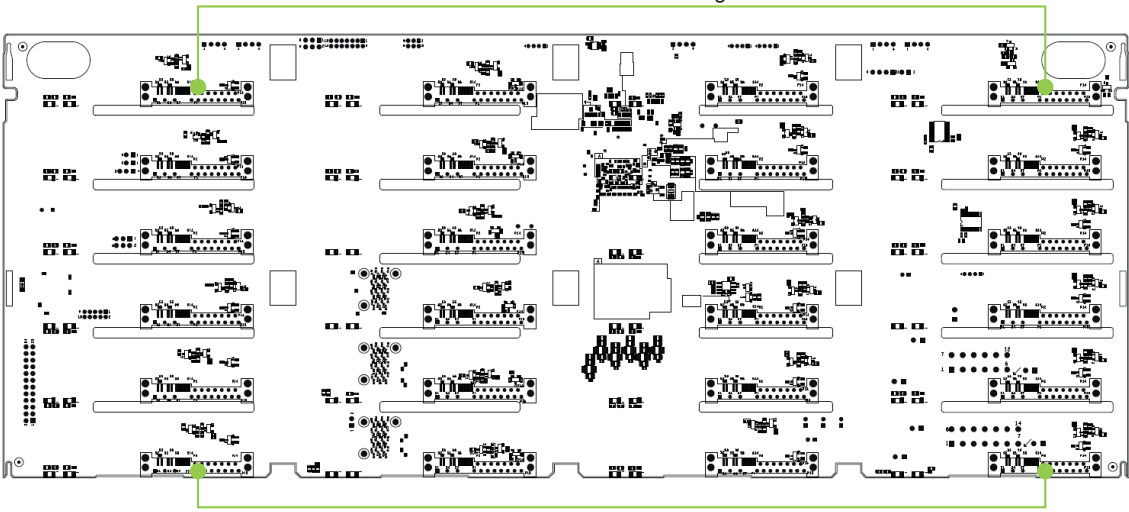

Connects to SATA/SAS storage device

Bottom view

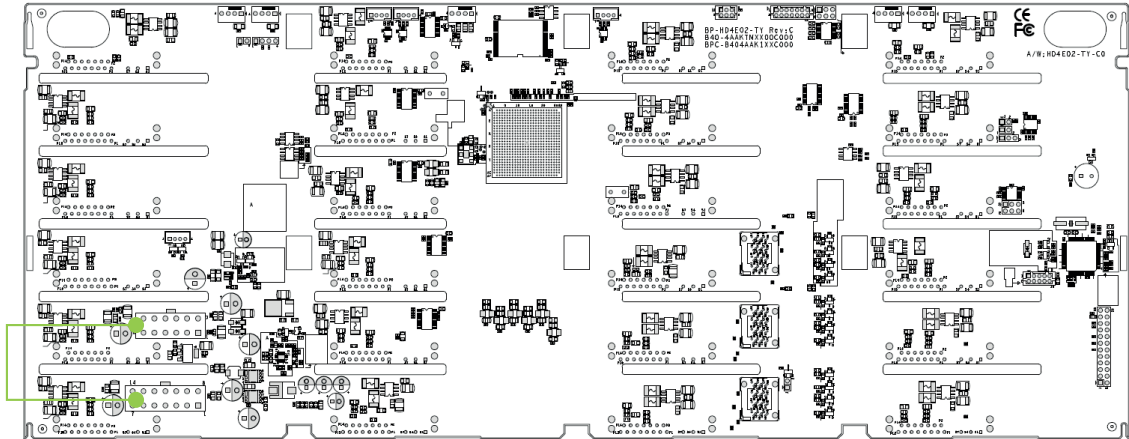

Connects motherboard to power source.

Chapter 4. BIOS Configuration Settings

This chapter demonstrates how to configure the UEFI BIOS settings in your system device. You can enter the BIOS screen during system startup.

To enter BIOS configuration settings,
Press **Esc** key during the Power-On-Self-Test (POST)

To enter BIOS after POST, you have to restart the system by using one of the three methods:

- Press **Ctrl + Alt + Delete**.
- Press the reset button on the system chassis.
- Turn the system off and on.



NOTE

The following pages provide the details of BIOS menu. Please notice that the BIOS menu are continually changing due to the BIOS update. The BIOS menu provided are the most updated ones when this manual is written.



NOTE

For further details about the BIOS, please refer to BIOS section in the Virgo manual for reference. AIC® website link: <https://www.aicpc.com/en/productdetail/20855>.

4.1 Navigation Keys

The navigation keys are listed below.

Function Key	Description
< ↑ > < ← > < → > < ↓ >	Select item.
< Enter >	Select and enter sub-screen.
< + > < - >	Modify selected option.
< F1 >	General help.
< F2 >	Previous Value.
< F3 >	Optimized defaults.
< F4 >	Save & Exit.
< F5 > < F6 >	Change values.
< F7 >	Discard Change and Exit.
< F9 >	Load Optimal Default for all values.
< F10 >	Save changes and exit.
< F12 >	Print Screen.
< Esc >	Exit the current menu screen.

4.2 BIOS Menu

Press ← and → to select the options of the menu bar. Press Enter to access the option screen.

Menu	Description
Main	Displays basic system information and date & time.
Advanced	Allows configuration of advanced system settings.
Security	Sets passwords and security functions.
Power	Sets the power management parameters.
Boot	Sets boot options, such as Quick Boot or USB Boot.

4.3 Main

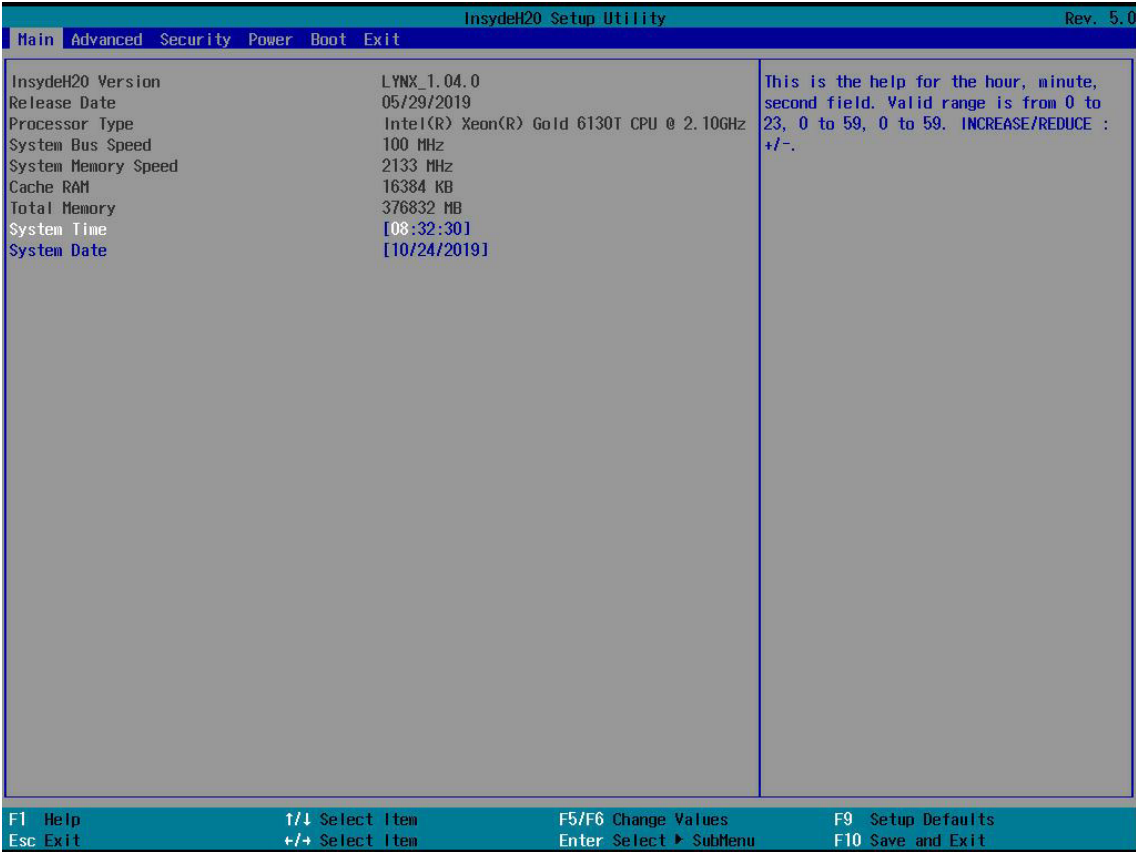

4.3.1 Main

Main	
System time	Configures the current time.
System date	Configures the current date.

4.4 Advanced

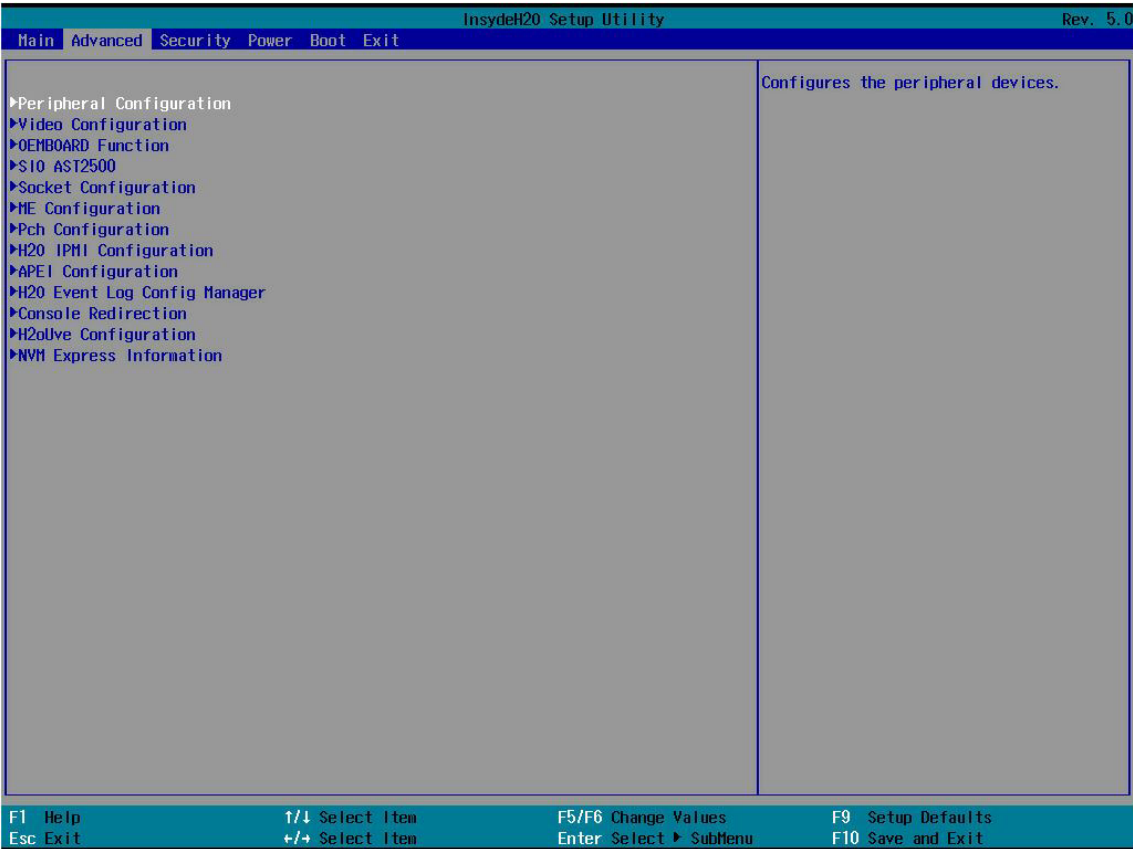

4.4.1 Peripheral Configuration

Peripheral Configuration		
PCIe SR-IOV	Enable	Disable
PCIe ARI	Enable	Disable
ARI Forward	Enable	Disable
Spread Spectrum	Enable	Disable

4.4.2 Video Configuration

Video Configuration		
Display Mode	Plug In First	On Board First

4.4.3 OEMBoard Function

OEMBoard Function					
Messiah Function	SMBIOS Updated	SMBIOS Updated	Auto	By Utility	
	SMBIOS TO BMC Redfish	Write SMBIOS to BMC	Enable	Disable	
	Halt On Error Function	Halt On Error	Enable	Disable	
	Manufacturing Function	Manufacturing Test Mode		Enable	Disable
		Dumped Storage		USB Storage	SATA Storage
		USB Test Function		Enable	Disable
		SATA Test Function		Enable	Disable

4.4.4 SIO AST2500

SIO AST2500				
Serial Port A	Auto	Enable	Disable	
Base I/O Address	2E8	2F8	3E8	3F8
Interrupt	IRQ3		IRQ4	
Serial Port B	Auto	Enable	Disable	
Base I/O Address	2E8	2F8	3E8	3F8
Interrupt	IRQ3		IRQ4	
Serial Port D	Auto	Enable	Disable	
Base I/O Address	2E8	2F8	3E8	3F8
Interrupt	IRQ7		IRQ10	

4.4.5 Socket Configuration

Socket Configuration						
Processor Configuration	Per-Socket Information	Hyper-Threading [ALL]	Enable	Disable		
		VMX	Enable	Disable		
		Enable SMX	Enable	Disable		
		Extended APIC	Enable	Disable		
Common RefCode Configuration	MMCFG Size	64M	128M	256M		
		512M	1G	2G		
	MMIO High Base	56T	40T	24T		
		16T	4T	1T		
	MMIO High Granularity Size	1G	4G	16G		
		64G	256G	1024G		
Serial Debug Message Level	Disable	Minimum				
	Normal	Maximum				
UPI Configuration	UPI General Configuration	UPI Status	Link Speed Mode	Slow	Fast	
			Link Frequency Select	Auto	9.6Gb/s	
				10.4Gb/s	Use Per Link Setting	
			Link L0p Enable	Auto	Enable	Disable
			Link L1 Enable	Auto	Enable	Disable
			Legacy VGA Socket	Min=0, Max=3		
			Legacy VGA Stack	Min=0, Max=6		
Memory Configuration	Integrated Memory Controller (iMC)	Enforce POR	Auto	POR	Disable	
		Memory Frequency	Auto	Selections in MHz		
		IMC BCLK	Auto	100 MHz	133 MHz	
		MRC Promote Warnings	Enable	Disable		
		Promote Warnings	Enable	Disable		
		Halt on mem Training Error	Enable	Disable		
		Attempt Fast Boot	Auto	Enable	Disable	
		Attempt Fast Cold Boot	Auto	Enable	Disable	
		MemTest On Fast Boot	Auto	Enable	Disable	
		Enable ADR	Enable	Disable		
		2x Refresh Enable	Auto	Enable	Disable	

Memory Configuration	Memory Map	Volatile Memory Mode	Auto	1LM	2LM	
		AppDirect cache	Auto	Enable	Disable	
		eADR Support	Auto	Enable	Disable	
		1LM Memory Interleave Granularity	Auto	256B Target, 256B Channel	64B Target, 64B Channel	
		IMC Interleaving	Auto	1-way Interleave	2-way Interleave	
		Channel Interleaving	Auto	1-way Interleave	3-way Interleave	
		Rank Interleaving	Auto	1-way Interleave	2-way Interleave	
		Socket Interleave Below 4GB	Enable	Disable		
				4-way Interleave	8-way Interleave	
	Memory RAS Configuration	Static Virtual Lockstep Mode	Enable	Disable		
		Mirror mode	Enable Mirror Mode (1LM)	Disable		
		Mirror TAD0	Enabled	Disable		
		Enable Partial Mirror	Partial Mirror Mode (1LM)	Disable		
		UEFI ARM Mirror	Enable	Disable		
		Memory Rank Sparing	Enable	Disable		
		Correctable Error Threshold	Min= 0x0, Max= 0x7fff			
		SDDC Plus One	Enable	Disable		
		ADDDC Sparing	Enable	Disable		
		Set NGN Die Sparing	Enable	Disable		
		Patrol Scrub	Enable	Disable		
		Patrol Scrub Interval	Min=0, Max=24			
		Patrol Scrub Address Mode	Reverse Address	System Physical Address		
	NGN Configuration	NGNVM DIMM Secure Erase Unit	NGN Factory Reset/Clear	Enable	Disable	
			Average Power Budget	Min=10000, Max=18000		
			Publish ARS capability	Auto	Enable	Disable
			NGN CMD Time	Auto	1N	2N
			NGN ECC Read Check	Auto	Enable	Disable
			Thermal Throttling Thresholds Offset	Auto	Enable	
			CR Fast Go Configuration	Auto	Default	Option 1 ~ 5
			CR Latch System ShutdoWn State	Enable	Disable	
			Snoopy mode for 2LM	Enable	Disable	
			Extended Type 17 Structure	Enable	Disable	
			Enable power cycle policy	Enable	Disable	
Snoopy mode for AD	Enable	Disable				

Memory Configuration	NGN Configuration	NGNVM DIMM Secure Erase Unit	App Direct Memory Hole	Enable	Disable	
			LSx implementation	SWSMI	ASL	
			SMBus Max Access Time	Min= 0, Max= 4294967295		
			SMBus Release Delay	Min= 0, Max= 4294967295		
			Erase All DIMMs	Enable	Disable	
			S0 CH0~5 S1 CH0~5 S2 CH0~5 S3 CH0~5	Enable	Disable	
	Memory Dfx Configuration	Load NGN DIMM Management Drivers	Auto	Enable	Disable	
		Memory Interleaving	Auto	NUMA	2-way Node Interleave	4-way Node Interleave
		Lock NGN CSRs	Auto	Enable	Disable	
		NGN ECC Correctable error	Auto	Enable	Disable	
		NGN ECC Write Check	Auto	Enable	Disable	
		NGN ECC Write Retry Flow Exit	Auto	Enable	Disable	
		C/A Parity Enable	Auto	Enable	Disable	
		High Address Region	Auto	Bit Postion 33~45		
		Low Mem Channel Config	Auto	Channel 0	Channel 1	Channel 2
		CLX A0 Starve Threshold	Enable	Disable		
		Configuration Mask for 2LM	Normal	Aggressive		
		CR Halt/Warn Mixed SKU	Auto	Enable	Disable	
		Crystal Ridge ACPI Debug Interface	ACPI Debug Object	COM1		
		NFIT debug logs	Enable	Disable		
		NFIT NVDIMM SKU Based	Enable	Disable		
		Publish NVDIMM DIMM Ctrl Region SPA	Enable	Disable		
		Skip ARS on Boot	Enable	Disable		
		ECC Checking	Auto	Enable	Disable	
		2GB Short Stroke Configuration	Interleaved	Non-Interleaved	Disable	
		Force 1-Ch Way in FM 2-2-2 Configuration	Enable	Disable		

I/O Configuration	PCI 64-Bit Resource Allocation	Enable		Disable			
	PCIe Train by BIOS	Yes		No			
	PCIe Hot Plug	Auto	Manual	Enable	Disable		
	PCIe ACPI Hot Plug	Enable		Disable		Per-Port	
	PCI-E Completion Timeout (Global) Disable	Yes		No		Per-Port	
	PCI-E Global Timeout Value	50us to 10ms	16ms to 55ms	65ms to 210ms	260ms to 900ms		
		1s to 3.5s	4s to 13s	17s to 64s			
	PCI-E ASPM Support (Global)	L1 Only		Disable		Per-Port	
	IOAT Configuration	Sck0 IOAT Config	Disable TPH	Yes		No	
			Prioritize TPH	Enable		Disable	
			Relaxed Ordering	Enable		Disable	
			IOAT Function 0/1/2/3/4/5/6/7 Items	DMA		Enable	
				No Snoop		Enable	
						Disable	
	Intel® VT for Directed I/O (VT-d)	Intel® VT for Directed I/O (VT-d)	Enable		Disable		
		Interrupt Remapping	Enable		Disable		
		PassThrough DMA	Enable		Disable		
		ATS	Enable		Disable		
		Posted Interrupt	Enable		Disable		
		Coherency Support (Non-Isch)	Enable		Disable		
		Access Control Services	Enable		Disable		
	Intel® VMD technology	Intel® VMD for Volume Management Device on Socket 0/1/2/3	Intel® VMD for Volume Management Device for PStack0~PStack2	Enable		Disable	
			VMD port 1A~1D/2A~2D/3A~3D	Enable		Disable	
			Hot Plug Capable	Enable		Disable	
			CfgBar size	Min=20, Max=28			
			CfgBar attribute	32-bit non-prefetchable			
				64-bit non-prefetchable			
				64-bit prefetchable			
			MemBar1 size	Min=12, Max=47			
MemBar1 attribute			32-bit non-prefetchable				
			64-bit non-prefetchable				
	64-bit prefetchable						
MemBar2 size	Min=12, Max=47						

I/O Configuration	Intel® VMD technology	Intel® VMD for Volume Management Device on Socket 0	MemBar2 attribute	32-bit non-prefetchable			
				64-bit non-prefetchable			
				64-bit prefetchable			
Advanced Power Configuration	CPU P State Control	WFR Uncore GV Rate Reduction	Auto	Enable	Disable		
		Uncore Freq Scaling (UFS)	Enable		Disable		
		AVX ICCP pre-grant level	128 Heavy	256 Light	256 Heavy		
			512 Light		512 Heavy		
		SpeedStep (Pstates)	Enable		Disable		
		Config TDP	Normal	Level 1	Level 2		
		P State Domain	All		One		
		EIST PSD Function	HW_ALL	SW_ALL	SW_ANY		
		SINGLE_PCTL	Enable		Disable		
		Single Power Domain (SPD)	Enable		Disable		
		Boot performance mode	Max Performance	Max Efficient	Set by Intel Node Manager		
		Energy Efficient Turbo	Enable		Disable		
		Turbo Mode	Enable		Disable		
		CPU Flex Ratio Override	Enable		Disable		
		Perf P-Limit Differential	Min=0, Max=7				
		Perf P-Limit Clip	Min=0, Max=31				
		Perf P-Limit Threshold	Min=0, Max=31				
	Perf P Limit	Enable		Disable			
	Hardware PM State Control	Hardware P-States	Disable		Native Mode		
			Out of Band Mode		Native Mode with No Legacy Support		
		HardwarePM Interrupt	Enable		Disable		
		EPP Enable	Enable		Disable		
		APS rocketing	Enable		Disable		
		Scalability	Enable		Disable		
	RAPL Prioritization	Enable		Disable			
	Package C State Control	Package C State	C0/C1 state		C2 state		
			C6(non Retention)		C6(Retention) state		
			No Limit		Auto		
		C2C3TT	Min=0, Max=255				
		PKG C-state Lat. Neg.	Enable		Disable		
		LTR I/O Input	Take I/O LTR input		Ignore I/O LTR input		
		MDLL Off	Auto	Enable	Disable		
		Latency Tolerance Requirement	Snoop Latency Override	Enable		Disable	
			Force Snoop Latency Override	Enable		Disable	
			Snoop Latency Multiplier	Min=0, Max=7			
	Force Non-Snoop Latency Override		Min=0x0, Max=0x3ff				

Advanced Power Configuration	Package C State Control	Latency Tolerance Requirement	Non-Snoop Latency Override	Enable	Disable		
			Non-Snoop Latency Multiplier	Min=0, Max=7			
			Non-Snoop Latency Value	Min=0x0, Max=0x3ff			
		Pkg C-state SA Power Management Control			CPU0 SAPMCTL_CFG/ CPU1 SAPMCTL_CFG/ CPU2 SAPMCTL_CFG/ CPU3 SAPMCTL_CFG	IIO0_PKGC_CLK_GATE_DISABLE	Enable Disable
						IIO1_PKGC_CLK_GATE_DISABLE	Enable Disable
						IIO2_PKGC_CLK_GATE_DISABLE	Enable Disable
						UPI01_PKGC_CLK_GATE_DISABLE	Enable Disable
						UPI23_PKGC_CLK_GATE_DISABLE	Enable Disable
						MC1 PKGC CLK GATE DISABLE	Enable Disable
						MC0 PKGC CLK GATE DISABLE	Enable Disable
						UPI01 PLL Shutdown En	Enable Disable
						UPI23 PLL Shutdown En	Enable Disable
						PCIe IIO0 PLL Shutdown En	Enable Disable
						PCIe IIO1 PLL Shutdown En	Enable Disable
						PCIe IIO2 PLL Shutdown En	Enable Disable
						MC0 PLLs Shutdown En	Enable Disable
						MC1 PLLs Shutdown En	Enable Disable
						SetVID Decay Disable	Enable Disable
						SAPMCTL_CFG LOCK	Enable Disable

4.4.6 ME Configuration

ME Configuration					
Server ME Configuration	General ME Configuration	Altitude	Min=0x0, Max=0xffff		
		MCTP Bus Owner	Min=0x0, Max=0xffff		
Server ME General Configuration	Server ME General Configuration	ME Initialization Complete Timeout	Min=0, Max=12		
		Enable HSIO Messaging	Enable Disable		
		DRAM Init Done Enable	0 1 None		
		DRAM Initialization Status	Auto - true status	0 - Success	
			1 - No Memory in Channels	2 - Memory Init Error	
		Host Reset Warning	0 1 None		
		Enable Pre-DramInit Done ME Reset	0 1 None		
		HMRFP0_LOCK Message	Enable Disable		
		HMRFP0_ENABLE Message	Enable Disable		
		END_OF_POST Message	Enable Disable		
		HECI-1 Enable HECI-2 Enable HECI-3 Enable	Enable Disable		
		Core Bios Done Message	Enable Disable		
		Server ME Debug Configuration	Override ICC Clock Settings	Override ICC Clock Settings	0
					1
					None
ICC Clock Spread Spectrum	0				
	1				
	None				
Boot Mode Override	0				
	1				
	None				
Boot Mode	Performance Optimized				
	Power Optimized				
Cores Disable Override	0				
	1				
	None				
Cores To Disable	Min=0x0, Max=0x7f				
Power Measurement Override	0				
	1				
	None				
Power Measurement	Enable Disable				
Hardware Change Override	0				
	1				
	None				
Hardware Changed	Yes				
	No				
Server ME Debug Configuration	NM Configuration	NM Configuration			

4.4.7 PCH Configuration

PCH Configuration						
PCH Devices	PCH state after G3	S0		S5		Last State
PCH SATA Configuration	SATA Controller	Enable			Disable	
	Configure SATA as	AHCI			RAID	
	Support Aggressive Link Power Management	Enable			Disable	
	Port 0~7	Enable			Disable	
	SATA Port 0 DevSlp	Enable			Disable	
	Hot Plug	Enable			Disable	
	Configure as eSATA	Enable			Disable	
	Mechanical Presence Switch	Enable			Disable	
	Spin Up Device	Enable			Disable	
	SATA Device Type	Hard Disk Drive			Sata State Drive	
PCH sSATA Configuration	sSATA Controller	Enable			Disable	
	Configure sSATA as	AHCI			RAID	
	Support Aggressive Link Power Management	Enable			Disable	
	Port 0~5	Enable			Disable	
	sSATA Port 0~5 DevSlp	Enable			Disable	
	Hot Plug	Enable			Disable	
	Configure as eSATA	Enable			Disable	
	Spin Up Device	Enable			Disable	
	sSATA Device Type	Hard Disk Drive			Sata State Drive	
	SATA Topology	Unknown	ISATA	Direct Connect	Flex	M2
USB Configuration	USB Precondition	Enable			Disable	
	USB Per-Connector Disable	Enable			Disable	
	USB XHCI MSI Disable WA	Enable			Disable	
	XHCI Over Current Pins	Enable			Disable	
	XHCI Wake On Usb Enable	Enable			Disable	
	Place XHCI BAR below 4GB	Enable			Disable	
ADR Configuration	Enable/Disable ADR	Platform-POR		Enable		Disable
	ADR GPIO	GPIO B			GPIO C	
	Host Partition Reset ADR Enable	Platform-POR		Enable		Disable
	Enable/Disable ADR Timer	Platform-POR		Enable		Held-off
	ADR timer expire time	Platform-POR	0 uS	25 uS	50 uS	100 uS
ADR timer multiplier	Platform-POR			x1, x8, x24, x40, x56, x64, x72, x80, x88, x96		

4.4.8 H2O IPMI Configuration

H2O IPMI Configuration				
IPMI Support	Enable		Disable	
BMC Warmup Time	Min=0, Max=240			
ACPI SPMI Table	Enable		Disable	
Boot Option Support	Enable		Disable	
Set BIOS version to BMC	Enable		Disable	
BMC Configuration	Watchdog Timer Support	Enable		Disable
	Not disable in OS	Enable		Disable
	Watchdog Timer Timeout	Min=2, Max=8		
	Watchdog Timer Action	No Action		Hard Reset
		Power Down		Power Cycle
	Power Cycle Time Support	Enable		Disable
	Power Cycle Time	Min=0, Max=255		
	Power Button	Enable		Disable
	Reset Button	Enable		Disable
	NMI Button	Enable		Disable
	LAN Port Configuration	Dedicated		Shared
	LAN Channel Number	Min=0, Max=15		
	IPv4 Source	Static		DHCP
	IPv6 Mode	Enable		Disable
IPv6 Prefix Length	Min=0, Max=255			
SDR List	SDR List Support	Enable		Disable

4.4.9 APEI Configuration

APEI Configuration						
ACPI Platform Error Interface	APEI Support	Enable			Disable	
	APEI Error Injection	MEMORY_CE	MEMORY_UE_NON_FATAL	MEMORY_UE_FATAL	PCIE_CE	
		PCIE_UE_NON_FATAL	PCIE_UE_FATAL	Disable		
	Defrag Level	ROM Space under 1/4	ROM Space under 1/3	ROM Space under 1/2	Every time When Error Occur	
	APEI UEFI Revision	UEFI 2.2			UEFI 2.3.1	

4.4.10 Console Redirection

Console Redirection											
Console Serial Redirection Setup	Console Serial Redirect	Enable					Disable				
	Terminal Type	VT_100		VT_100+		VT_UTF8		PC_ANSI			
	Baud Rate	1200	2400	4800	9600	19200	38400	57600	115200		
	Data Bits	7 Bits					8 Bits				
	Parity	Even			Odd			None			
	Stop Bits	1 Bits					2 Bits				
	Flow Control	RTS/CTS			XON/XOFF			None			
	Information Wait Time	0 Second		2 Second		5 Second		10 Second		30 Second	
	C.R. After Legacy Boot	Yes					No				
	Text Mode Resolution	AUTO		Force 80x25		Force 80x24 (DEL FIRST ROW)		Force 80x24 (DEL LAST ROW)		Limit 128x40 (Default)	
	Auto Refresh	Enable					Disable				
	Auto adjust Terminal resolution	Enable					Disable				

4.4.11 H2O Event Log Config Manager

H2O Event Log Config Manager						
Configuration Pages	BIOS Event Log Configuration	BIOS Event Log Viewer	Log Event To	ALL	BIOS	
				BMC SEL	Memory	Disable
			Event Log Full option	Overwrite	Clear All	Stop Logging
	POST Message Configuration	POST Message Configuration		Enable	Disable	
		Progress Code		Enable	Disable	
		Error Code		Enable	Disable	
		Debug Code		Enable	Disable	
		Log POST Message		Enable	Disable	
		Show POST Message		Enable	Disable	
	Serial Debug Message Configuration	EFI DEBUG Message Configuration	Advanced Mode	Enable	Disable	
			DEBUG_INIT	Enable	Disable	
			DEBUG_WARN	Enable	Disable	
			DEBUG_LOAD	Enable	Disable	
			DEBUG_FS	Enable	Disable	
			DEBUG_INFO	Enable	Disable	
			DEBUG_DISPATCH	Enable	Disable	
			DEBUG_VARIABLE	Enable	Disable	
			DEBUG_BM	Enable	Disable	
			DEBUG_BLKIO	Enable	Disable	
			DEBUG_NET	Enable	Disable	
			DEBUG_UNDI	Enable	Disable	
			DEBUG_LOADFILE	Enable	Disable	
			DEBUG_EVENT	Enable	Disable	
			DEBUG_GCD	Enable	Disable	
			DEBUG_CACHE	Enable	Disable	
			DEBUG_VERBOSE	Enable	Disable	
			DEBUG_ERROR	Enable	Disable	
			EFI DEBUG Message Level	Enable	Disable	
Status Code Serial Message Configuration	Show Progress Code Serial Message	Enable	Disable			
	Show Error Code Serial Message	Enable	Disable			
	Show Debug Code Serial Message	Enable	Disable			
Event And Message Pages	BIOS Event Log Viewer	Show BIOS Event Log				
	Serial Debug Message Viewer					

4.4.12 H2oUve Configuration

H2oUve Configuration			
H2oUve Setup	H2OUVE Support	Enable	Disable

4.5 Security

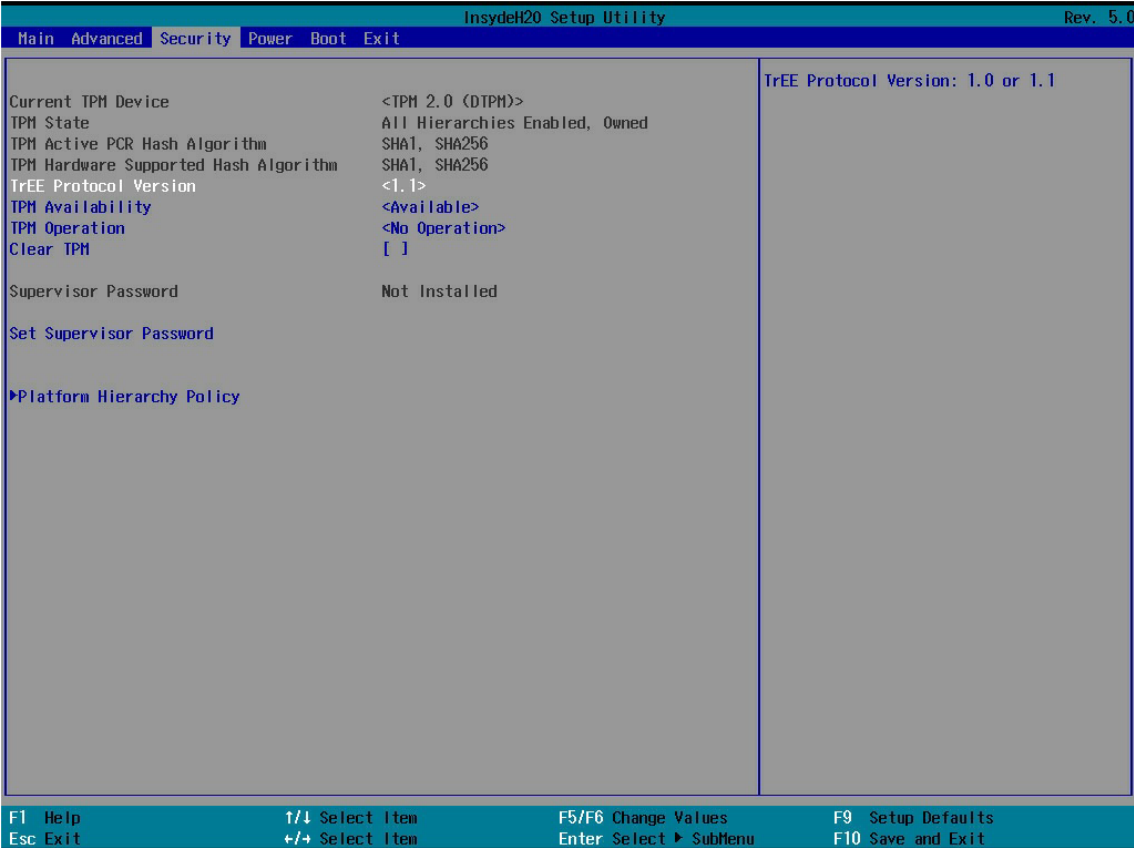

4.5.1 Security

Security			
Current TPM Device	Not Detected	TPM 1.2	TPM 2.0
TPM Active PCR Hash Algorithm	SHA1, SHA256		
TPM Hardware Supported Hash Algorithm	SHA1, SHA256		
TrEE Protocol Version	1.0	1.1	
TPM Availability	Available	Hidden	
TPM Operation	No operation	Disable and Deactivate	Enable and Activate
Clear TPM	0	1	None
Power on Password	Enable	Disable	

4.6 Power



4.6.1 Power

Power		
Wake on PME	Enable	Disable

4.7 Boot

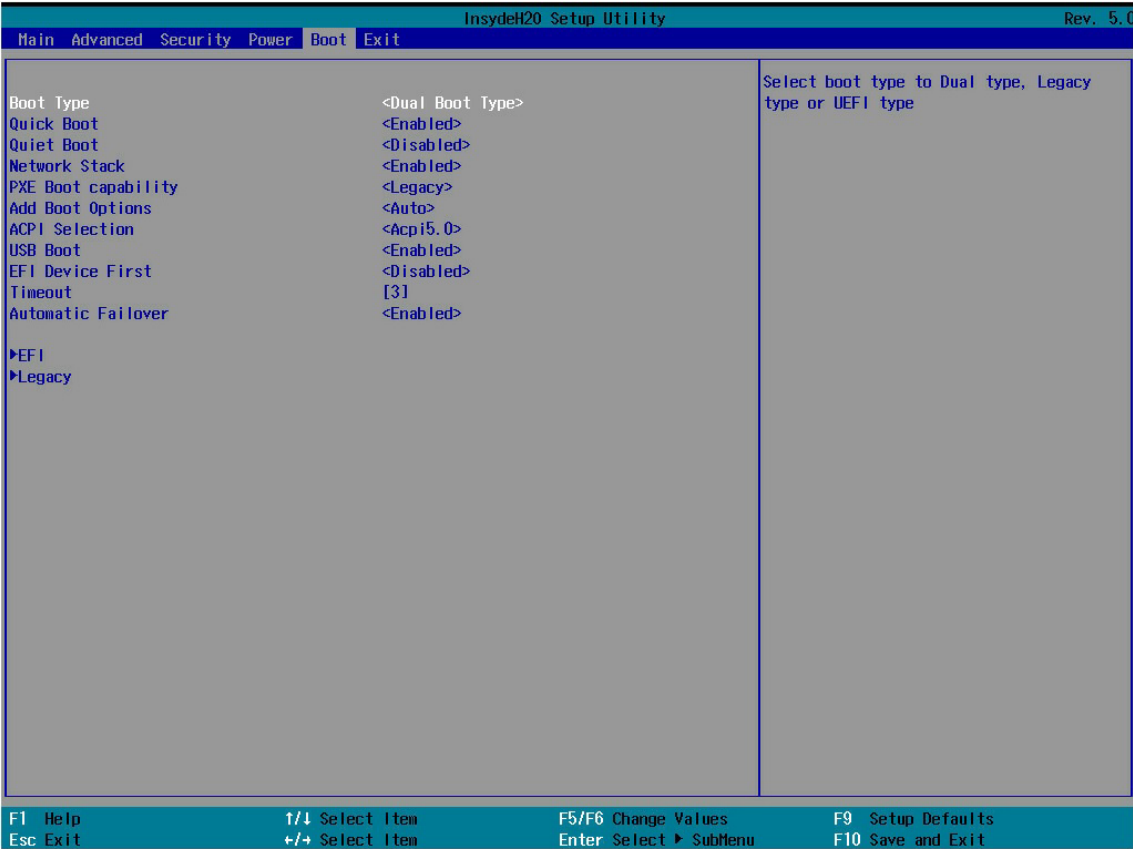

4.7.1 Boot

Boot			
Boot Type	Dual Boot Type	Legacy Boot Type	UEFI Boot Type
Quick Boot	Enable	Disable	
Quiet Boot	Enable	Disable	
Network Stack	Enable	Disable	
PXE Boot capability	Disable	UEFI:IPv4	UEFI:IPv6
	UEFI:IPv4/UEFI:IPv6		Legacy
Add Boot Options	First	Last	Auto
ACPI Selection	Acpi1.0B	Acpi3.0	Acpi4.0
	Acpi5.0	Acpi6.0	Acpi6.1
USB Boot	Enable	Disable	
EFI Device First	Enable	Disable	
Timeout	Min=0, Max=10		
Automatic Failover	Enable	Disable	
EFI	Normal Boot Menu	Normal	Advance
	Boot Type Order	Hard Disk Drive CD/DVD-ROM Drive USB PXE Other Device	
		Other Device	
Legacy	Boot Device Priority	Normal Boot Menu	Normal Advance
	Boot Type Order	Floppy Drive Hard Disk Drive CD/DVD-ROM Drive USB Others	
		USB	

4.8 Exit

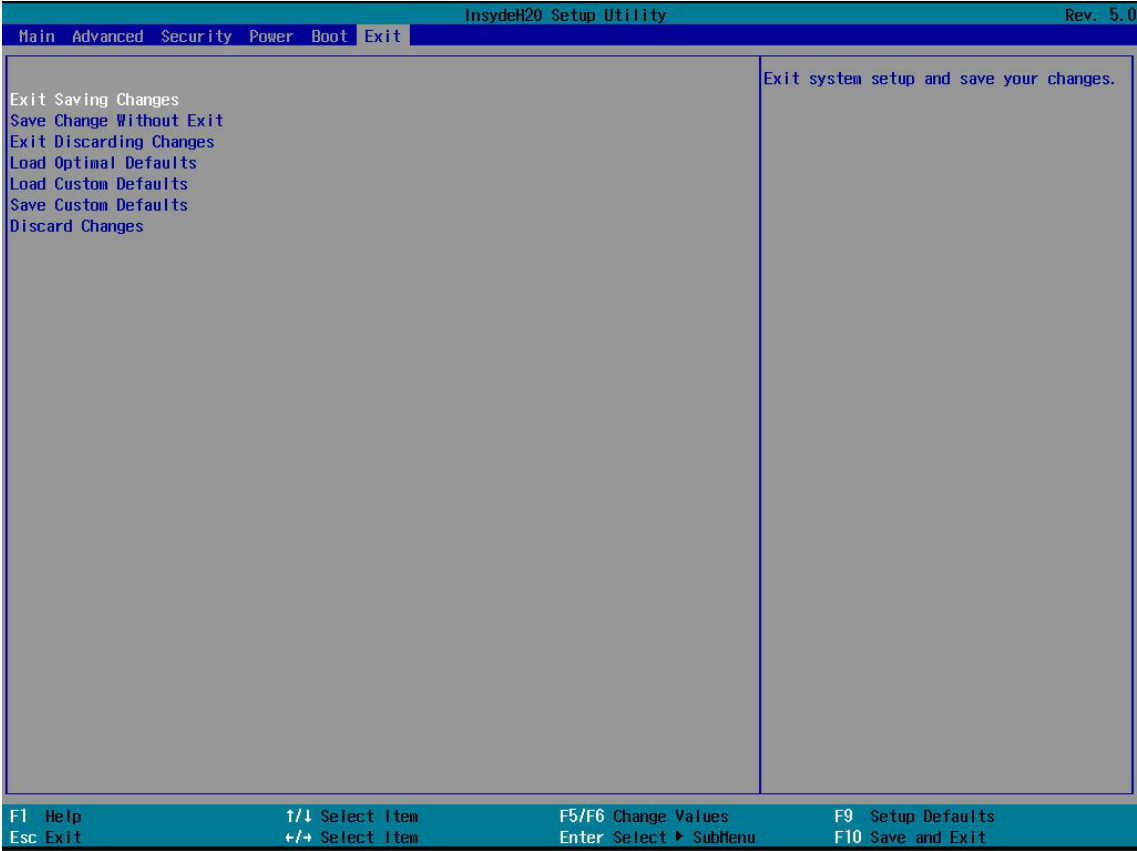

4.8.1 Exit

Exit	
Exit Saving Changes	Exit system setup and save your changes.
Save Change Without Exit	Save your changes without exiting the system.
Exit Discarding Changes	Discard your changes when existing the system.
Load Optimal Defaults	Load optimal default items.
Load Custom Defaults	Resets the BIOS settings to the default values and overwrites any previously customized settings.
Save Custom Defaults	Saves the cumostomized defaults in BIOS settings.
Discard Changes	Discard your changes.

Chapter 5. BMC Configuration Settings

Insert Ethernet LAN cable into the BMC LAN port. There are two methods to setup BMC IP:

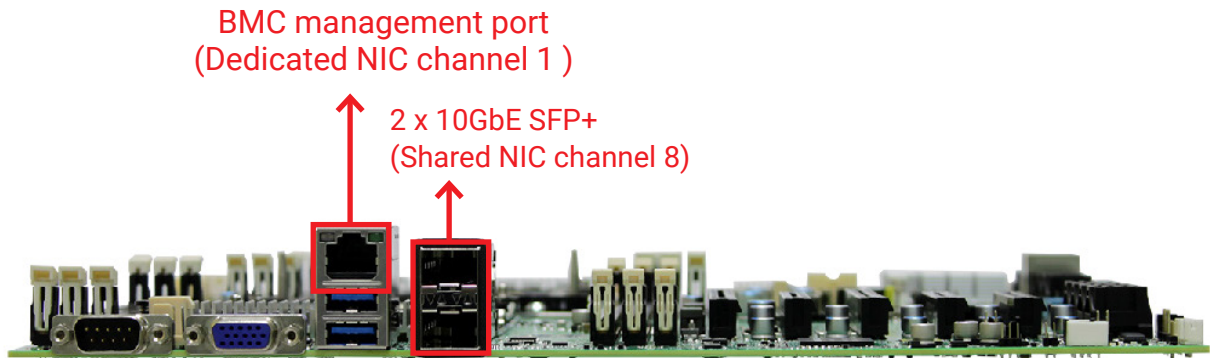

5.1 Setup

Step 1 BIOS SETUP → Advanced → H2O IPMI configuration → BMC Configuration → IPv4 source → Static

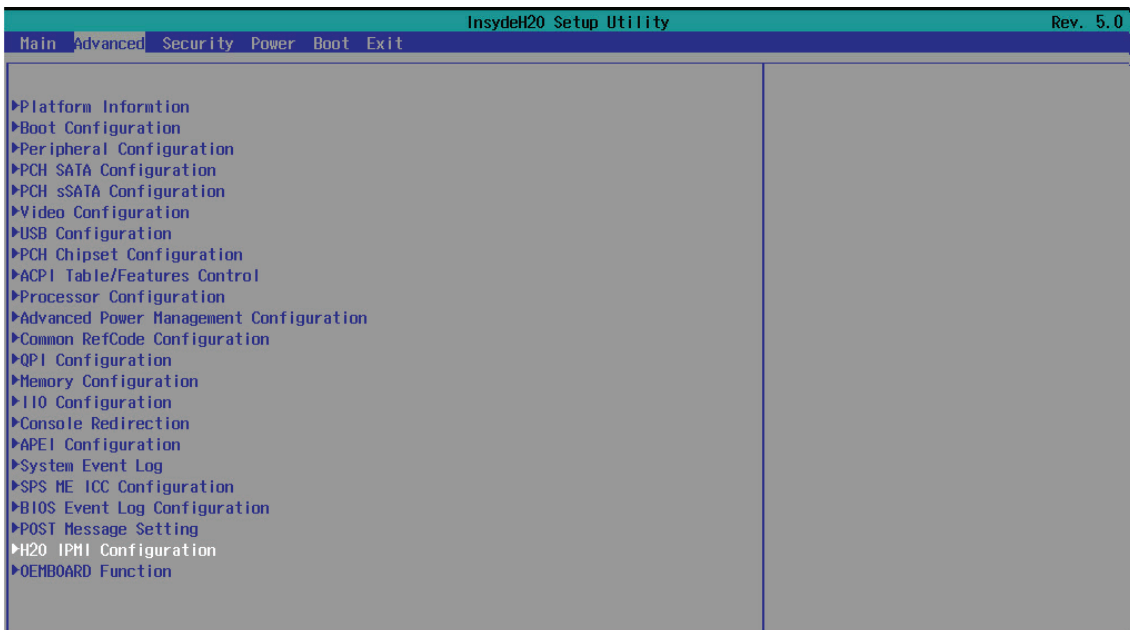

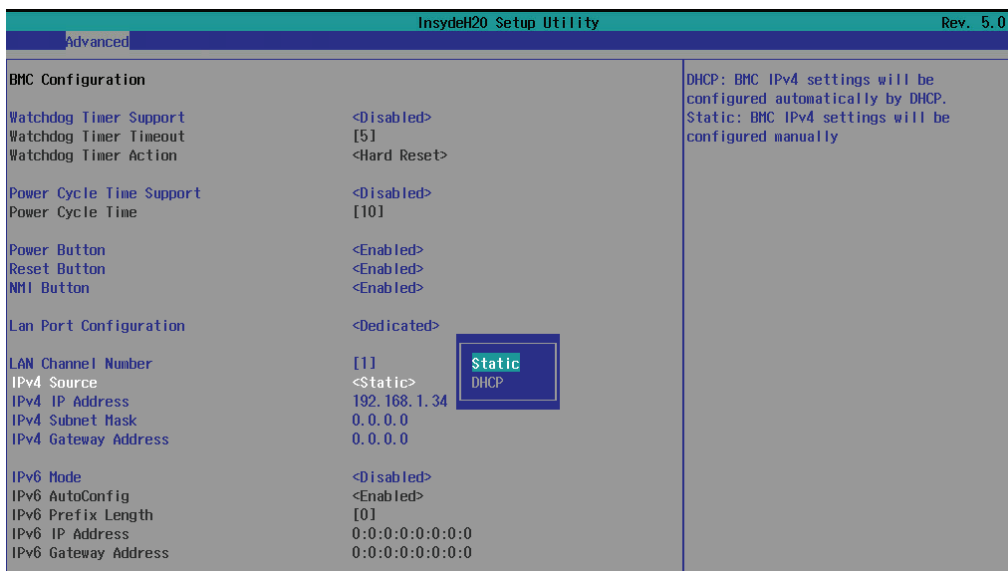
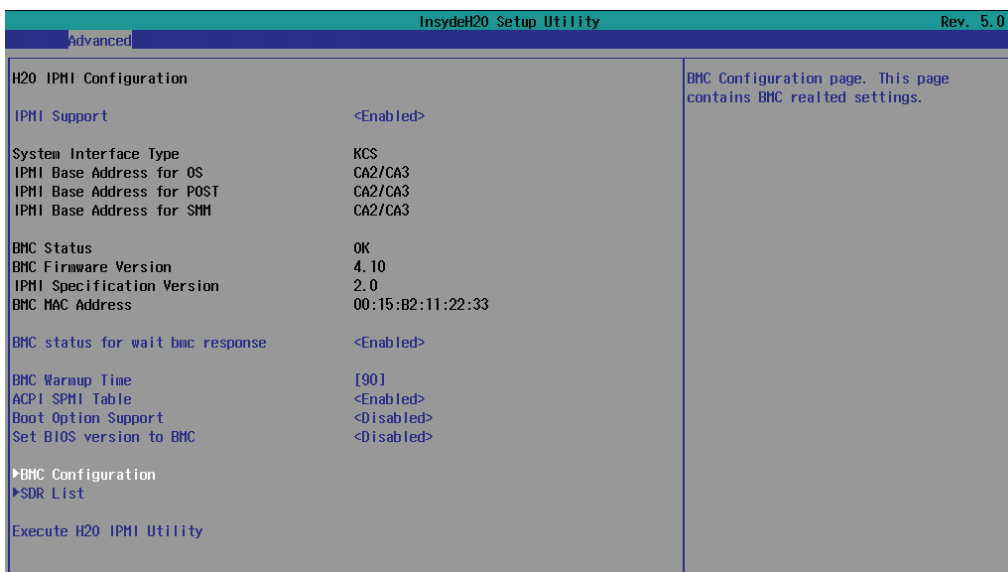

Step 2 Input the IP address. Set static IP.

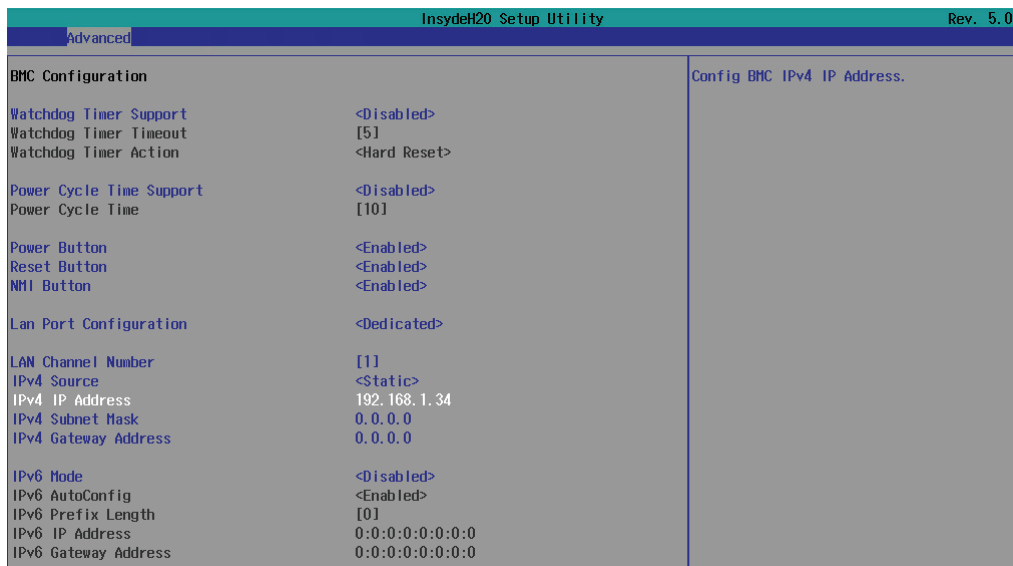

Step 3 Input the subnet mask address.

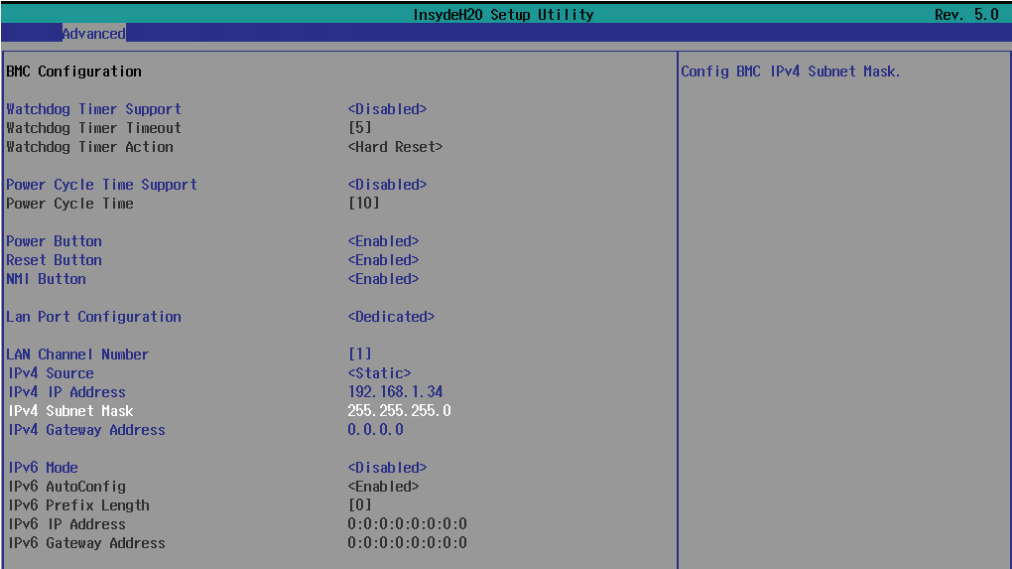

5.2 Web GUI

The IP address below is an example using the default IP setting. The IP address is configurable.

Step 1 Open the browser then type default BMC IP address: 192.168.22.22

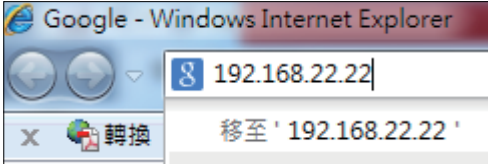

Step 2 Use the default user name and password for first-time login to BMC WEB GUI.

Field:	Default
User Name:	admin
Password:	admin

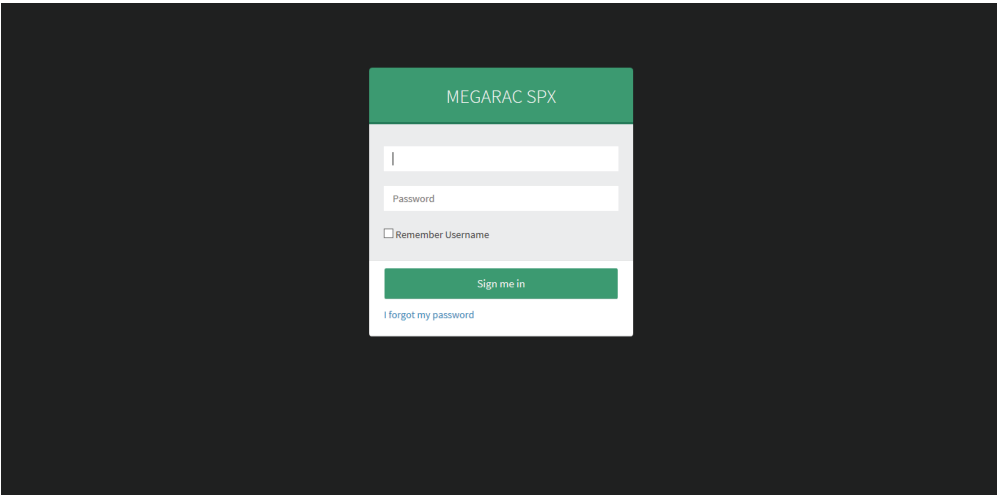

 **NOTE** The default user name and password are in lower-case characters.

 **NOTE** Users who login with the admin user name and password will have full administrative power. The admin password can be changed after login.

Dashboard: The Dashboard page gives the overall information about the status of a device.

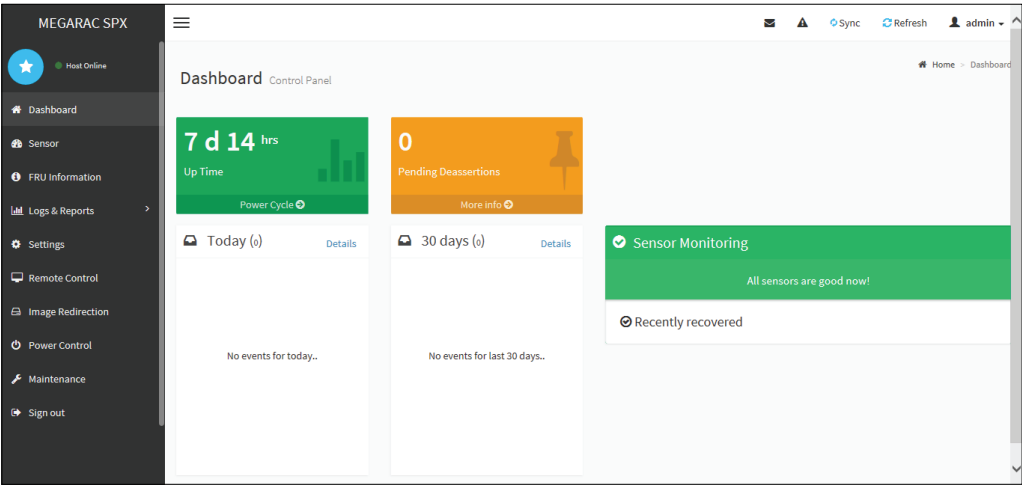

Server Health - Sensor Readings: Then Sensors Readings page displays all the sensor related information.

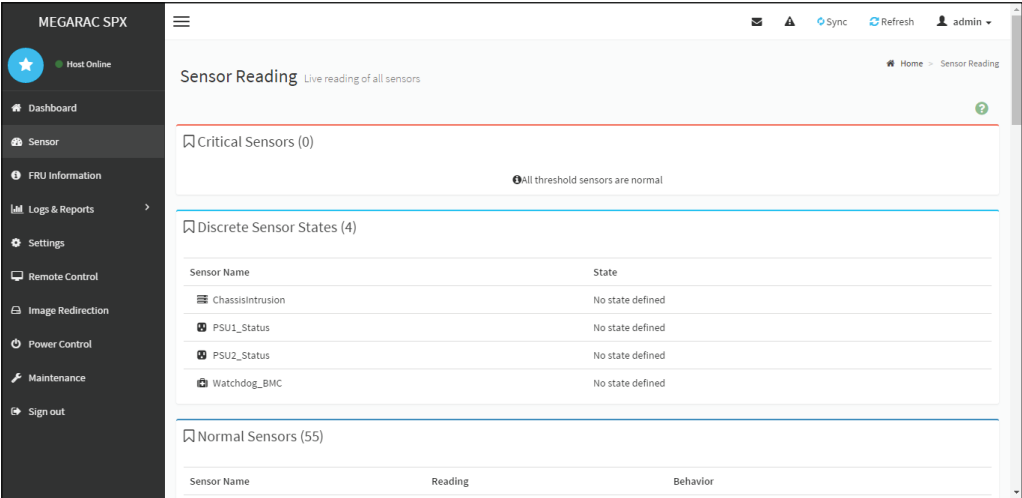

Settings: The Settings page allows you to access various configuration settings.

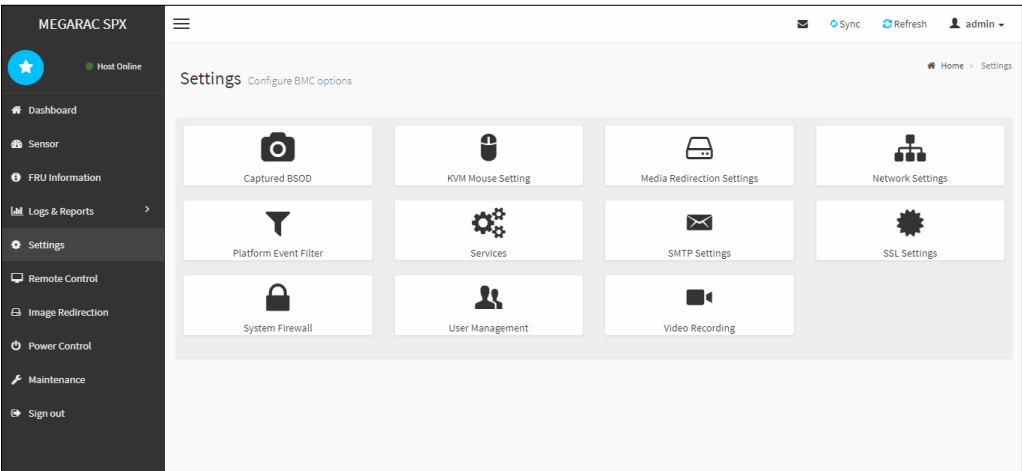

KVM Mouse Setting: The KVM Mouse Setting page displays the setting for mouse emulation from local window to remote screen.

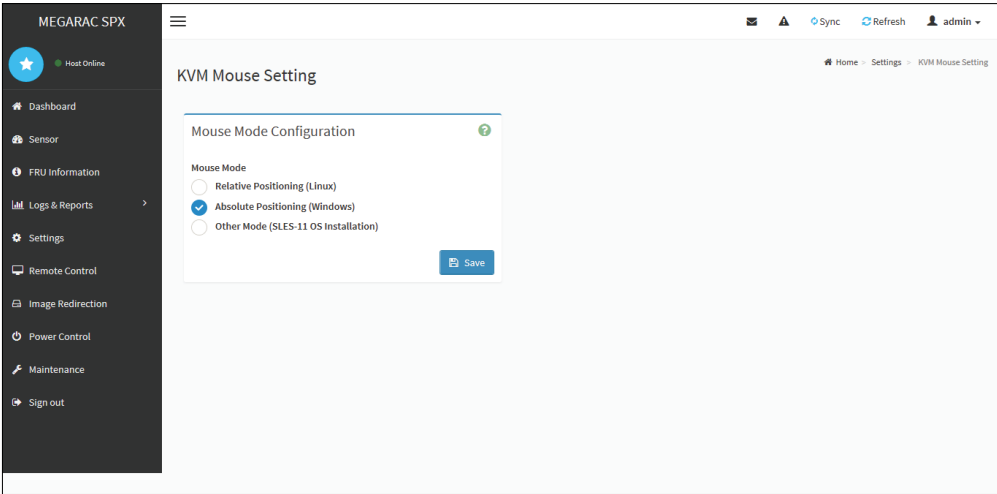

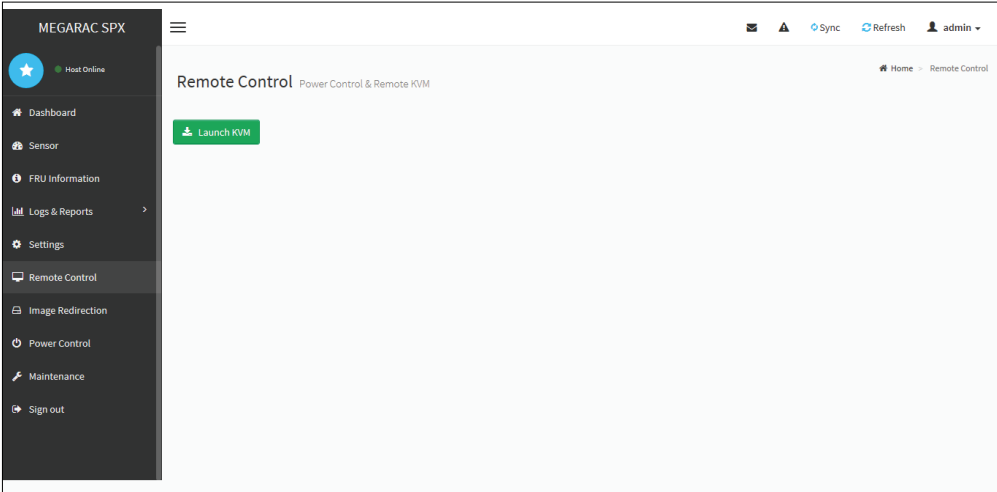

- For Windows OS environment, set mode to absolute.
- For Linux OS environment, set mode to relative.
- For SLES-11 OS environment, set mode to other mode.

Remote Control: The Remote Control page allow you to access any of the managed devices within your system.

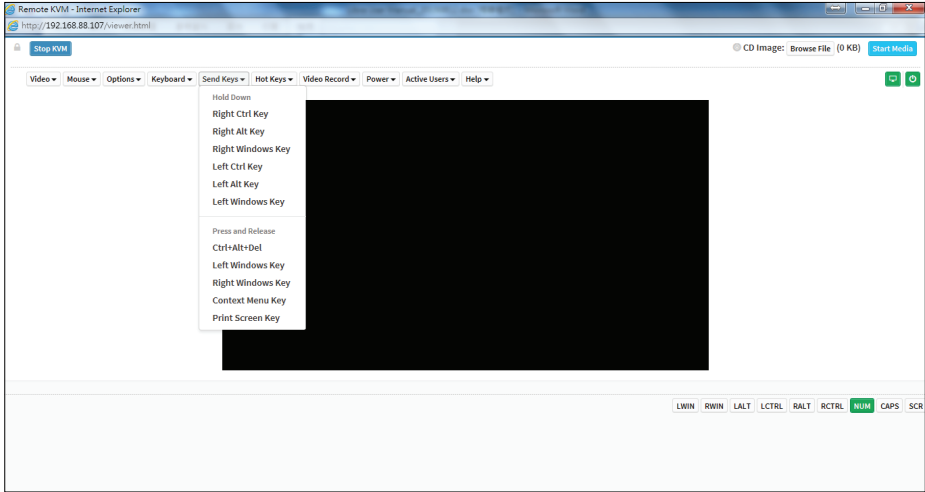

Environmental setting:



 **NOTE** For further details about the BMC, please refer to BMC section in the Virgo manual for reference. AIC® website link: <https://www.aicpc.com/en/productdetail/20855>.

Chapter 6. RAID Configuration

This firmware (LSI® Integrated RAID solution) provides protection for the system boot volume. This firmware features 4 fundamental RAID attributes:

- The Integrated Mirroring (RAID 1)
- The Integrated Mirroring + Striping (RAID 10)
- The Integrated Mirroring Enhanced (RAID 1E)
- The Integrated Striping (RAID 0)

6.1 Mirrored Volume Configuration

Enter SAS3 BIOS CU to configure and manage Integrated RAID volumes.

6.1.1 Create Mirrored Volumes

Procedure

Step 1: Load BIOS and press **Ctrl+C** to initiate SAS3 BIOS CU.

The following message will appear: Please wait, invoking SAS Configuration Utility...

Step 2: Wait for a few seconds for the Adapter List window to appear.

NOTE



In some systems, the following message will pop up instead: LSI Corp Configuration Utility will load following initialization! If this occurs, the SAS3 BIOS CU will load after the system completes POST.

6.1.2 Create Integrated Mirroring Volume

Create a two-disk Integrated Mirroring (RAID 1) volume.

Procedure

Step 1: In Adapter List window, select an LSI SAS-3 adapter and press **Enter**. The Adapter Properties window is shown below.

Adapter Properties Window page

```
LSI Corp Config Utility      v8.00.00.12 (2011.10.20)
Adapter Properties -- SAS3108_1

Adapter          Eval Board
PCI Slot         01
PCI Address(Bus/Dev) 04:00
MPT Firmware Revision 0.250.24.00-IR
SAS Address      500605B0:11223344
NUDATA Version   00.0A.00.02
Status           Enabled
Boot Order       0
Boot Support     [Enabled BIOS & OS]

RAID Properties
SAS Topology
Advanced Adapter Properties

Esc = Exit Menu      F1/Shift+1 = Help
Enter = Select Item  -/+Enter = Change Item
```

Step 2: Select **RAID Properties** and press **Enter**.

Step 3: Select Create RAID 1 Volume.

Step 4: Select a line that has a No entry in the RAID Disk column. , press the space bar to change the **No** to **Yes** to add the disk to the new array. This disk is the Primary disk in the array.

Step 5: Select another line and press the space bar to add the second disk to the array. This disk is the Secondary disk in the array.

Step 6: Press **C** to create the array. A menu window will appear.

Step 7: From the menu options, select **Save changes** and then exit this menu.

6.1.3 Create an Integrated Mirroring Enhanced/Mirroring + Striping Volume

Create an Integrated Mirroring Enhanced (RAID 1E) or Integrated Mirroring + Striping (RAID 10) volume.

Procedure

Step 1: In the Adapter List window, select an LSI SAS-3 adapter and press **Enter**.

Step 2: Select **RAID Properties** and press **Enter**.

Step 3: Select Create RAID 1E Volume.

Step 4: Select a line that has No entry in the RAID Disk column. Press the **space bar** to change **No** to **Yes** to add the disk to the new array.

Step 5: Select another line and press the **space bar** to add another disk to the array.

NOTE

If you select an odd number of disks, the SAS3 BIOS CU creates an Integrated Mirroring Enhanced array. If you select an even number of disks, it creates an Integrated Mirroring + Striping array. As you add disks, the Array Size field changes to reflect the size of the new array.

Step 6: Press **C** to create the array. A menu window will appear.

Step 7: From the menu options, select **Save changes** and then exit this menu. A message will appear briefly. SAS3 BIOS CU will return to the Adapter Properties window. Initialization of the new array continues in the background.

6.1.4 Expand an Integrated Mirroring Volume with OCE

Expand an existing RAID 1 volume with OCE.

Procedure

- Step 1: Replace one of the two volume disk drives with a drive that has at least 50 GB more capacity.
- Step 2: Wait until synchronization completes on the new disk and the volume returns to the Optimal state.
- Step 3: Replace the other volume disk drive with a drive that has at least 50 GB more capacity.
- Step 4: Wait until synchronization completes on the new disk and the volume returns to the Optimal state.
- Step 5: In the Adapter List window, select the LSI SAS adapter with the RAID 1 volume and press **Enter**.
- Step 6: Select RAID Properties and press **Enter**. The Select New Array Type window will appear.
- Step 7: Select **View Existing Array**. If necessary, press **Alt + N** to switch to the RAID 1 volume with the new, higher-capacity disk drives.
- Step 8: Select **Manage Volume**. The Manage Volume window will appear.
- Step 9: Select **Online Capacity Expansion**. A menu window will appear with a warning message and with options to start the expansion process or quit.
- Step 10: Press **Y** to start the expansion. The RAID Properties window will appear when the expansion process completes.
- Step 11: Run a commercial tool specific to the operating system to move or increase the size of the partition on the newly expanded RAID 1 volume.

6.2 Manage Hot Spare Disks

Create/delete one or two global hot spare disks to safeguard the data on mirrored volumes on the controller.

6.2.1 Create Hot Spare Disks

Add global hot spare disks to an existing volume.

Procedure

Step 1: Select the adapter on which you want to create hot spare disks and press **Enter**.

Step 2: Select **RAID Properties** and press **Enter**.

Step 3: Select **View Existing Array**. The View Array window will appear. If necessary, press **Alt + N** to switch to another array.

Step 4: Select **Manage Volume**. The Manage Volume window will appear as shown below.

Figure 6 Manage Volume Window page

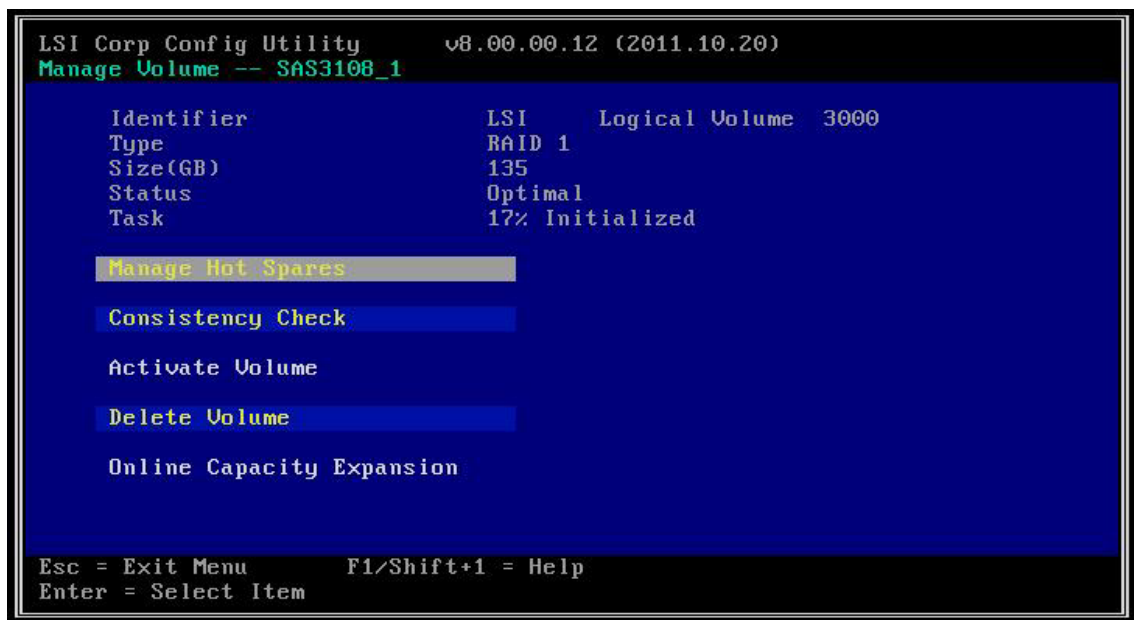

Step 5: Select **Manage Hot Spares**.

Step 6: Identify a disk that is not part of a RAID array and that is not identified as a hot spare disk.

NOTE

A global hot spare disk must have 512-byte blocks and nonremovable media. The disk type must be either SATA with extended command set support or SAS with SMART support.

Step 7: Select the Hot Spare field for this disk and press the **space bar**. The Hot Spare status changes to Yes.

Step 8: Repeat the preceding step to select a second global hot spare disk (optional).

Step 9: Press **C** to create the hot spare disk. A menu window will appear.

NOTE

An error message will appear if the selected disk is not at least as large as the smallest disk used in the existing array or arrays. An error message will also appear if you try to add a SATA disk as a hot spare for arrays that use SAS disks, or if you try to add a SAS disk as a hot spare for arrays that use SATA disks.

Step 10: Select **Save changes** and then exit this menu to create the hot spare disk or disks.

6.2.2 Delete a Hot Spare Disk

Delete a global hot spare disk.

Procedure

Step 1: Access the Manage Hot Spares window by following the first five steps of [Section 1.2.1](#).

Step 2: Select a hot spare disk to delete and press **C**.

Step 3: Select [Save changes](#) and then exit this menu to complete the deletion of the hot spare disk. The configuration utility pauses while it removes the global hot spare.

6.3 Other Configuration Tasks

This section explains how to perform other configuration and maintenance tasks for mirrored arrays.

6.3.1 View Array Properties

View the RAID properties of a mirrored array.

Procedure

Step 1: In the Select an adapter from the adapter list.

Step 2: Select [RAID Properties](#). The Select New Array Type window will appear.

Step 3: Select [View Existing Array](#).

6.3.2 Run a Consistency Check

Use the Consistency Check command to verify that the data is synchronized on the mirrored disks in the array.

Run a consistency check on a selected mirrored array:

Procedure

Step 1: Select an adapter.

Step 2: Select [RAID Properties](#) and press Enter.

Step 3: Select [View Existing Array](#). If necessary, press **Alt + N** to switch to another array on this adapter.

Step 4: Select [Manage Volume](#). The Manage Volume window will appear.

Step 5: Select [Consistency Check](#) in the Manage Volume window.

Step 6: Press **Y** to start the consistency check. The consistency check will run in the background. If it encounters any data mismatches, it will store the information in a bad block table.

6.3.3 Activate an Array

Activate a selected array.

Procedure

Step 1: Select an adapter and press **Enter**.

Step 2: Select **RAID Properties** and then press **Enter**.

Step 3: Select **View Existing Array**. If necessary, press **Alt + N** to switch to another array on this adapter.

Step 4: Select **Manage Volume**.

Step 5: Select **Activate Array** in the Manage Volume window.

Step 6: Press **Y** to activate the array. Wait a few seconds for the array to activate.

6.3.4 Delete an Array

Delete a selected array.

Procedure

Step 1: Select an adapter.

Step 2: Select RAID Properties and then press **Enter**.

Step 3: Select **View Existing Array**. If necessary, press **Alt + N** to switch to another array on this adapter.

Step 4: Select **Manage Volume**. The Manage Volume window will appear.

Step 5: Select **Delete Array**. A menu window will appear.

Step 6: Press **Y** to delete the array or press **N** to cancel the deletion process. Wait for a few seconds to delete the array.

NOTE

If there is another remaining array and one or two hot spare disks, the BIOS checks the hot spare disks to determine if they are compatible with the remaining array. If they are not compatible (too small or wrong disk type), the BIOS deletes them also.

6.3.5 Locate Disk Drives in a Volume

Locate disk drives by flashing their LEDs.

Procedure

Step 1: Select the a controller on the Adapter List window and press **Enter**.

Step 2: Highlight SAS Topology and press **Enter**. The SAS Topology window will appear.

Step 3: Select the disk in the Device Identifier column and press **Enter**. The LED on the disk will flash until you press a key to stop it.

Step 4: To identify all the disk drives in a volume, select the volume in the left column of the SAS Topology window and press **Enter**. The LED will flash on all disk drives in the volume until you press a key to stop them.

6.3.6 Select a Boot Disk

Select a boot disk.

Procedure

Step 1: Select an adapter from the adapter list.

Step 2: Select the SAS Topology option. If a device is currently designated as the boot device, the Device Info column on the SAS Topology window lists the word Boot, as shown below.

Boot Device on SAS Topology Window page

```

LSI Corp Config Utility      v8.00.00.12 (2011.10.20)
SAS Topology -- SAS310B_1

Eval Board(04:00)
├─ Controller
│  ├─ Slot 4
│  │  └─ RAID Physical Disk
│  │     └─ SAS
│  │
│  ├─ Slot 5
│  │  └─ RAID Physical Disk
│  │     └─ SAS
│  │
│  ├─ Slot 6
│  │  └─ IR DISK - HOT SPARE
│  │     └─ SAS
│  │
│  └─ Slot 7
│     └─ SEAGATE ST9146852SS 0005
│        └─ SAS,Boot
├─ RAID1 VOL
│  └─ LSI Logical Volume 3000
│     └─ SEAGATE ST9146803SS 0006
│        └─ RAID
│           └─ SEAGATE ST9146803SS 0003
│              └─ RAID
│                 └─ SEAGATE ST9300603SS 0006
│                    └─ Hot Spare

```

Esc = Exit F1/Shift+1 = Help
Alt+D = Device Properties Alt+M = More Keys

If a device is currently designated as the alternative boot device, the Device Info column will show the word Alt.

Step 3: Select the boot disk and press **Alt + B**.

Step 4: Select the current boot disk and press **Alt + B** to remove the boot designator.

Step 5: Select the new boot disk and press **Alt + B** to change the boot disk.

Step 6: Select the disk and press **Alt + A** to select an alternative boot disk.

6.4 Integrated Striping

Configure Integrated Striping volumes.

6.4.1 Integrated Striping Configuration

Procedure

Step 1: Load BIOS and press **Ctrl+C** to initiate SAS3 BIOS CU.

The following message will appear: Please wait, invoking SAS Configuration Utility..

Step 2: Wait for a few seconds for the Adapter List window to appear.

NOTE

In some systems, the following message will pop up instead: LSI Corp Configuration Utility will load following initialization! If this occurs, the SAS3 BIOS CU will load after the system completes POST.

6.4.2 Create Integrated Striping Volumes

Create one or two Integrated Striping volumes on each LSI SAS-3 controller.

Procedure

Step 1: Select an adapter and press **Enter**. The Adapter Properties window is shown below.

Adapter Properties Window page

```

LSI Corp Config Utility      v8.00.00.12 (2011.10.20)
Adapter Properties -- SAS3108_1

Adapter          Eval Board
PCI Slot         01
PCI Address(Bus/Dev) 04:00
MPT Firmware Revision 0.250.24.00-IR
SAS Address      500605B0:11223344
NVDATA Version   00.0A.00.02
Status           Enabled
Boot Order       0
Boot Support     [Enabled BIOS & OS]

RAID Properties
SAS Topology
Advanced Adapter Properties

Esc = Exit Menu      F1/Shift+1 = Help
Enter = Select Item  -/+ /Enter = Change Item
  
```

Step 2: Select **RAID Properties** and press **Enter**.

Step 3: Select **Create RAID 0 Volume**. The Create New Array window will appear.

Step 4: Select a line that has a No entry in the RAID Disk column. change the **No** to **Yes** by pressing the **space bar** to add the disk to the new array.

Step 5: Select another line and press the **space bar** to add another disk to the array.

Step 6: Continue adding disks until you reach the aimed number of disks.

Step 7: Press **C** to create the array.

Step 8: From the menu options, select **Save changes** and then exit this menu. A message will appear briefly, and then the SAS3 BIOS CU returns to the Adapter Properties window. Initialization of the new array will continue in the background.

6.4.3 Other Configuration Tasks

View Array Properties

View the RAID properties of an array.

Step 1: Select an adapter from the adapter list.

Step 2: Select [RAID Properties](#).

Step 3: Select [View Existing Array](#). The View Array window will appear, showing information about the array and each disk in it.

Step 4: If the currently displayed array is not the one you want, press [Alt + N](#) to view another array on the adapter.

Activate an Array

Activate a selected array.

Step 1: Select an LSI SAS adapter and press [Enter](#). The Adapter Properties window will appear.

Step 2: Select [RAID Properties](#) and press [Enter](#).

Step 3: Select [View Existing Array](#). If necessary, press [Alt + N](#) to switch to another array on this adapter.

Step 4: Select [Manage Volume](#). The Manage Volume window will appear.

Step 5: Select [Activate Array](#) in the Manage Volume window. A menu window will appear.

Step 6. Press [Y](#) to activate the array. The array becomes active after a pause.

Delete an Array

Delete a selected array.

Step 1: Select an adapter.

Step 2: Select [RAID Properties](#) and press [Enter](#).

Step 3: Select [View Existing Array](#). If necessary, press [Alt + N](#) to switch to another array on this adapter.

Step 4: Select [Manage Volume](#). The Manage Volume window will appear.

Step 5: Select [Delete Array](#).

Step 6: Either press [Y](#) to delete the array, or press [N](#) to cancel the deletion process. Wait for a few seconds to delete the array.

Locate Disk Drives in a Volume

Locate disk drives by flashing their LEDs.

Procedure

Step 1: Select the controller on the Adapter List window and press **Enter**.

Step 2: Highlight SAS Topology and press **Enter**. The SAS Topology window will appear.

Step 3: Select the disk in the Device Identifier column and press **Enter**. The LED on the disk will flash until you press a key to stop it.

Step 4: To identify all the disk drives in a volume, select the volume in the left column of the SAS Topology window and press **Enter**. The LEDs flash on all disk drives in the volume until you press a key to stop them.

Select a Boot Disk

Select a boot disk.

Procedure

Step 1: Select an adapter from the Adapter List.

Step 2: Select the SAS Topology option. If a device is currently designated as the boot device, the Device Info column on the SAS Topology window lists the word Boot as shown below.

Boot Device on SAS Topology Window page

```

LSI Corp Config Utility      v8.00.00.12 (2011.10.20)
SAS Topology -- SAS310B_1

Eval Board(04:00)
├─ Controller
│  └─ Slot 4
│     └─ Slot 5
│        └─ Slot 6
│           └─ Slot 7
├─ RAID1 VOL
│  └─ Slot 4
│     └─ Slot 5
│        └─ Slot 6
└─

Device Identifier      Device Info
-----
Direct Attach Devices
RAID Physical Disk    SAS
RAID Physical Disk    SAS
IR DISK - HOT SPARE   SAS
SEAGATE ST9146852SS    0005    SAS,Boot
LSI Logical Volume    3000
SEAGATE ST9146803SS    0006    RAID
SEAGATE ST9146803SS    0003    RAID
SEAGATE ST9300603SS    0006    Hot Spare

Esc = Exit  F1/Shift+1 = Help
Alt+D = Device Properties  Alt+M = More Keys
  
```

If a device is currently designated as the alternative boot device, the Device Info column shows the word Alt.

Step 3: Select the preferred boot disk and press **Alt + B**.

Step 4: Select the current boot disk and press **Alt + B** to remove the boot designator.

Step 5: Select the new boot disk and press **Alt + B** to change the boot disk.

Step 6: Select an alternative boot disk and press **Alt + A**.

6.5 Intel® RSTe

Intel® RSTe (Rapid Storage Technology enterprise) is a software that supports systems equipped with SSDs, SATA or SAS devices. The purpose of its utility is to manage and configure RAID systems. Supported features of Intel® RSTe include SATA RAID Option ROM, SCU RAID Legacy Option ROM, SATA/SCU RAID UEFI Driver, Graphical User Interface, CSMI (Common Storage Management Interface), hot plug, SCU and AHCI drive roaming, SGPIO on SCU, hot spare disk, RAID smart support and many other features. To view the complete features and instructions about Intel® RSTe, please visit the Intel® website for further details.

Chapter 7. Technical Support



www.aicipc.com

Taiwan, Global Headquarters

Address: No. 152, Section 4,
Linghang N. Rd, Dayuan District,
Taoyuan City 337, Taiwan
Tel: +886-3-433-9188
Fax: +886-3-287-1818
Sales Email: sales@aicipc.com.tw
Support Email: support@aicipc.com

Shanghai, China

Address: Room 215, Building 4, No.471
Guiping Road, Xuhui District, Shanghai City,
200233 China
Tel: +86-21-54961421
Sales Email: sales@aicipc.com.cn
Support Email: support@aicipc.com

Moscow, Russia

Address: No.500, 5th Floor, 5th Entrance,
32A, Khoroshevskoye Shosse, Moscow,
123007
Tel: +7-4997019998
Sales Email: support-ru@aicipc.com.tw
Support Email: rma.russia@aicipc.com.tw

North California, United States

Address: 48531 Warm Springs
Boulevard Suite 404 Fremont, CA
94539, United States
Tel: +1-510-573-6730
Sales Email: sales@aicipc.com
Support Email: support@aicipc.com

South California, United States

Address: 21808 Garcia Lane
City of Industry, CA 91789,
United States
Toll free: + 1-866-800-0056
Tel: +1-909-895-8989
Fax: +1-909-895-8999
Sales Email: sales@aicipc.com
Support Email: support@aicipc.com

New Jersey, United States

Address: 322 Route 46 West Suite 100
Parsippany, NJ 07054 United States
Tel: +1-973-884-8886
Fax: +1-973-884-4794
Sales Email: sales@aicipc.com
Support Email: support@aicipc.com

Houten, The Netherlands

Address: Peppelkade 58, 3992AK, Houten,
The Netherlands
Tel: +31-30-6386789
Fax: +31-30-6360638
Sales Email: sales@aicipc.nl
Support Email: support@aicipc.com

For additional technical support or questions about trouble shooting, please contact the AIC® representative nearest to you or visit our AIC® website for more information.
AIC® website: <https://www.aicipc.com/en/faq>.