



# RSC-2KTS

## Rackmount Chassis User's Manual

# Table of Contents

<b>Preface</b> .....	<b>i</b>
<b>Safety Instructions</b> .....	<b>ii</b>
<b>About This Manual</b> .....	<b>iv</b>
<b>Chapter 1. Product Features</b> .....	<b>1</b>
1.1 Box Content .....	1
1.2 Specifications .....	2
1.3 Feature .....	2
<b>Chapter 2. Hardware Setup</b> .....	<b>5</b>
2.1 Top Cover .....	5
2.2 Power Supply Unit Module .....	6
2.3 Fan Module .....	7
2.4 Hard Disk Drive .....	8
2.4.1 External 3.5-inch Drive .....	8
2.4.2 External 2.5-inch Drive (Optional).....	9
2.4.3 Internal 2.5-inch Drive (Optional) .....	10
2.5 HDD Backplane Module .....	11
2.6 Slide Rail Installation.....	12
<b>Chapter 3. Hardware Specifications</b> .....	<b>15</b>
3.1 Drive Backplane: 4 Bays.....	15
3.1.1 Placement.....	15
3.1.2 Connector and Jumper .....	15
3.1.3 LED Indicator .....	16
3.2 Drive Backplane: 2 Bays.....	17
3.2.1 Placement.....	17
<b>Chapter 4. Technical Support</b> .....	<b>18</b>

## Document Release History

<b>Release Date</b>	<b>Version</b>	<b>Update Content</b>
January 2021	1	User's Manual release to public.
July 2021	1.1	Content update.
September 2021	1.2	Update datasheet.



**Copyright © 2021 AIC®, Inc. All Rights Reserved.**

This document contains proprietary information about AIC® products and is not to be disclosed or used except in accordance with applicable agreements.

# Preface

## Copyright

No part of this publication may be reproduced, stored in a retrieval system, or transmitted in any form or by any means, electronic, mechanical, photo-static, recording or otherwise, without the prior written consent of the manufacturer.

## Trademarks

All products and trade names used in this document are trademarks or registered trademarks of their respective holders.

## Changes

The material in this document is for information purposes only and is subject to change without notice.

## Warning

1. A shielded-type power cord is required in order to meet FCC emission limits and also to prevent interference to the nearby radio and television reception. It is essential that only the supplied power cord be used.
2. Use only shielded cables to connect I/O devices to this equipment.
3. You are cautioned that changes or modifications not expressly approved by the party responsible for compliance could void your authority to operate the equipment.

## Disclaimer

AIC® shall not be liable for technical or editorial errors or omissions contained herein. The information provided is provided "as is" without warranty of any kind. To the extent permitted by law, neither AIC® or its affiliates, subcontractors or suppliers will be liable for incidental, special or consequential damages including downtime cost; lost profits; damages relating to the procurement of substitute products or services; or damages for loss of data, or software restoration. The information in this document is subject to change without notice.

# Safety Instructions

*Before you commence, please attentively read the following important discretions below. All cautions and warnings on the equipment or in the manuals should be circumspactly noted and reviewed.*

**Always ground yourself to prevent static electricity.**

請全程接地，以防止靜電。

请全程接地，以防止静电。

**Всегда заземляйте себя, чтобы избежать статического электричества.**

**Aard jezelf altijd om statische elektriciteit te voorkomen.**

- Firmly ground yourself at all times when installing or assembling the internal components of the server. Most of electronic components in the server are highly sensitive to electrical static discharge.
- Use a solid grounding wrist strap and distintively place all electronic components in static-shielded devices to prevent static. Grounding wrist straps can be purchased in any electronic supply store.
- Confirm that the power source is turned off and then disconnect the power cords from your system before performing any type of installation or manual servicing. A sudden surge of power could serverly damage the sensitive electronic components.
- Do not precipitously open the system's top cover. If you must open the cover for maintenance purposes, only a trained technician should be allowed to proceed this action. Integrated circuits on computer boards are highly sensitive to static electricity. Before operating a board or integrated circuit, touch an unpainted portion of the system unit chassis for a couple of seconds to discharge any static electricity on your body.

**Place the server in a stable environment.**

請將伺服器放置在穩定的環境中。

请将伺服器放置在穩定的環境中。

**Поместите сервер в стабильную среду.**

**Plaats de server in een stabiele omgeving.**

- Place this equipment on a stable surface when installing. A small mild drop or fall could cause fatal injury to both the equipment and the person handling the equipment.
- Please keep this equipment away from humidity to prevent vast rust and disintergration.
- Carefully and accurately mount the equipment into the rack. Uneven mechanical loading may lead to hazadous consequences.
- This equipment is to be installed for operation in an environment with maximum ambient temperature below 35°C.
- Review the environment before performing any installation or servicing. Keep the equipment away from hazardous and uneven grounds.
- This server must be installed only in Restricted Acss Locations.

**Handle equipment with care.**

請謹慎操作設備。

请谨慎操作设备。

**Обращайтесь с оборудованием осторожно.**

**Behandel de apparatuur voorzichtig.**

- Do not cover the openings of the system. The openings on the system are for air convection, which intentionally protect the equipment from overheating.
- Never pour any liquid into ventilation openings of the system. This could cause catastrophic fire or electrical shock.

- Ensure that the voltage of the power source is within the specification on the label when connecting the equipment to the power outlet. The current load and output power of loads must be within the specification.
- This equipment must be firmly connected to reliable grounding before usage. Pay special attention to power supplied other than direct connections, e.g. using of power strips.
- Place the power cord out of the way of foot traffic. Do not place anything over the power cord. The power cord must be rated for the product, voltage and current marked on the product's electrical ratings label. The voltage and current rating of the cord should be greater than the voltage and current rating marked on the product.

**Pay attention to hardware maintenance.**

注意硬體維護。

注意硬体维护。

**Обратите внимание на обслуживание оборудования.**

**Besteed aandacht aan hardware-onderhoud.**

- If the equipment is not used for a long time, disconnect the equipment from mains to avoid being damaged by transient over-voltage.
- Module and drive bays must not be empty. They must have a dummy cover.
- Never open the equipment without professional assistance. For safety reasons, only qualified service personnel should open the equipment.
- If one of the following situations arise, the equipment should be checked and tested by service personnel:
  1. The power cord or plug is damaged.
  2. Liquid has penetrated the equipment.
  3. The equipment has been exposed to moisture.
  4. The equipment does not work well or will not work according to its user manual.
  5. The equipment has been dropped and/or damaged.
  6. The equipment has obvious signs of breakage.
  7. Please disconnect this equipment from the AC outlet before cleaning. Do not use liquid or detergent for cleaning. The use of a moisture sheet or cloth is recommended for cleaning.



**CAUTION**

The equipment intended for installation should be placed in Restricted Access Location.



**CAUTION**

There will be a risk of explosion if battery is replaced by an incorrect type. Dispose of used batteries according to the instructions. After performing any installation or servicing, make sure the enclosure is correct in position before turning on the power.



**CAUTION**

This unit may have more than one power supply. Disconnect all power sources before maintenance to avoid electric shock.



# About This Manual

Thank you for selecting and purchasing RSC-2KTS.

This user's manual is provided for professional technicians to perform easy hardware setup, basic system configurations, and quick software startup. This document pellucidly presents a brief overview of the product design, device installation, and firmware settings for 2KTS Rackmount Chassis. For the latest version of this user's manual, please refer to the AIC® website: <https://www.aicipc.com/en/productdetail/51217>.

## **Chapter 1 Product Features**

This chapter delivers the overall layout of the product, including the fundamental components of the rackmount chassis, design specifications, and noteworthy features.

## **Chapter 2 Hardware Setup**

This chapter displays an easy installation guide for assembling the chassis. Utmost caution for proceeding to set up the hardware is highly advised.

## **Chapter 3 Hardware Specifications**

This chapter elaborates the overall layout of the hardware design, including multifarious connectors, jumpers, and LED descriptions.

## **Chapter 4 Technical Support**

For more information or suggestion, please contact the nearest AIC® corporation representative in your district or visit the AIC® website: <https://www.aicipc.com/en/index>. It is our greatest honor to provide the best service for our customers.

# Chapter 1. Product Features

RSC-2KTS is a flexible rackmount storage chassis with tool-less design. This product supports hot swappable HDDs and easy swap fans. For more information about our product, please visit our website at <https://www.aicpc.com/en/index>.

Before removing the subsystem from the shipping carton, visually inspect the physical condition of the shipping carton. Exterior damage to the shipping carton may indicate that the contents of the carton are damaged. If any damage is found, do not remove the components; contact the dealer where the subsystem was purchased for further instructions. Before continuing, first unpack the subsystem and verify that the number of components in the shipping carton is accurate and in good condition.

## 1.1 Box Content

This product contains the components listed below.

Please confirm the number and the condition of the components before installation.

Pre-installed into the system		Number
✓	500W redundant power supply PMBus 1.2 80+ Platinum	1+1
✓	3.5-inch external hot swap disk drive tray	8
✓	PWM 80x25mm fan	3
✓	4-port SAS/SATA backplane with SFF-8643 connector	2
Accessory Item		Number
✓	Screw for motherboard: RW(+),M3X4L,NI	20
✓	Screw for 3.5" HDD, bottom: F(+),632X5L,NI	35
✓	S2600/Purley motherboard screw: RW M3*5L	1
✓	Air stop sponge: 45X20 MM T=25	2
✓	EPE foam for front board: 815*140*190H	1
✓	EPE foam for rear board: 815*140*190H	1
✓	EPE foam for front tray: 125*120*50T	1
✓	EPE foam for rear tray: 125*120*50T	1
✓	EPE tray for heat sink box: 80*70*20T	1
✓	Power cord	vary per region
✓	2U 500W single power unit	1
BTO	28-inch tool-less slide rail assembly	1
	2.5-inch external hot swap disk drive tray (7mm)	2
	2U 550W redundant power supply unit	1
	2U 800W redundant power supply unit	1+1
	2.5-inch internal disk drive tray	4
	2.5-inch internal disk tray and 1 slim DVD-ROM tray	2 and 1

**Product features are subject to change without notice.**

## 1.2 Specifications

<b>Dimensions</b> (W x D x H)	mm : 430 x 560 x 88		
	inches : 17 x 22 x 3.5		
<b>Industry Standard</b>	EIA-RS310D		
<b>Material</b>	Heavy-duty preplated SPGC cold-rolled steel		
<b>Color</b>	Front Panel : Black		
<b>Cooling</b>	3 x 80x25mm PWM cooling fans		
<b>Power Supply</b>	2U 550W single		
	<b>Options</b>	<ul style="list-style-type: none"> <li>• 2U 550W 1+1 redundant power supply Platinum</li> <li>• 2U 800W 1+1 redundant power supply Platinum</li> </ul>	
<b>Expansion Slots</b>	7 low profile		
<b>Front Panel</b>	System power on/off, system reset, 1 x USB 3.0 port and UID S/W		
<b>LED Indicators</b>	Power, LAN, Drive, Alert and UID		
<b>System Board</b>	Up to 12" x 9.6" ATX / SSI EEB 3.6 compliant MB		
<b>Drive Bays</b>	External	3.5" hot swap	8
		Optional *For XE1-2KTS0-02 / XE1-2KTS0-03	• 2 x 2.5" hot swap (7mm)
	Internal	2.5"	2 (15mm)
		Optional *For all SKUs	<ul style="list-style-type: none"> <li>• 2 x 2.5" (15mm)</li> <li>• 1 x slim DVD-Rom</li> </ul>

<b>Backplane</b>	2 x 4-port SATA/SAS backplanes with SFF-8643 connector	
<b>Storage Temperature</b>	0°C(32°F) ~ 50°C(122°F)	
<b>Humidity</b>	5%~95% non-condensing	
<b>Gross Weight</b>	(w/ PSU & Rail)	kgs : 23.5
		lbs : 51.8
<b>Packaging Dimensions</b>	(W x D x H)	mm : 645 x 835 x 224
		inches : 25.4 x 32.9 x 8.8
<b>Cubic Feet</b>	5.38	
<b>Container Load Quantity</b>	20'	200
	40'	420
	40' H	450
<b>Mounting</b>	Standard	28" tool-less slide rail

## 1.3 Feature

- Tool-less design supports quick installation and easy maintenance:
  - Tool-less 3.5" & 2.5" drive trays
  - Tool-less top covers
  - Tool-less slide rails
- Supports power cycling on single drive
- Specially designed hot swap and low power consumption fans minimize rotational vibration and provide superior cooling
- 3.5" drive tray comes with 4 screw holes to adapt to 2.5" drive
- Comes with a redundant PSU 80+ Platinum
- One front access USB 3.0 port

**Front Panel**

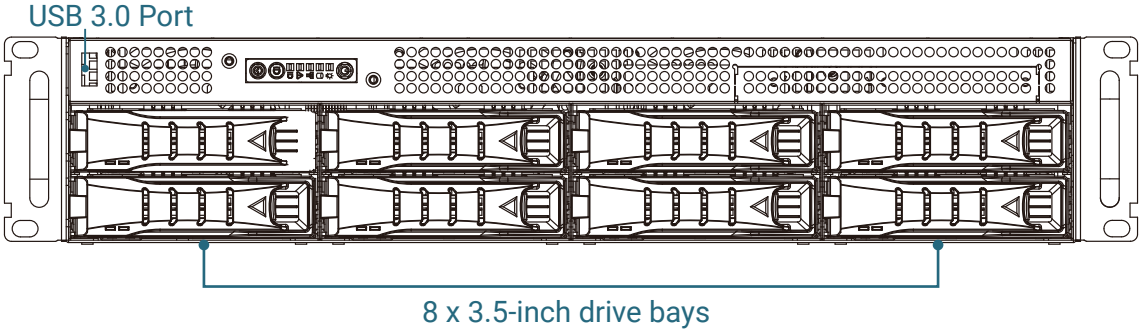

Item	Description
	Power Button
	Power Status LED Indicator
	Drive Activity LED Indicator
	LAN Activity LED Indicator
	System Alert LED Indicator
	ID LED Indicator
	System ID Button
	System Reset Button
	1 x USB 3.0 Type A port

**Rear Panel**

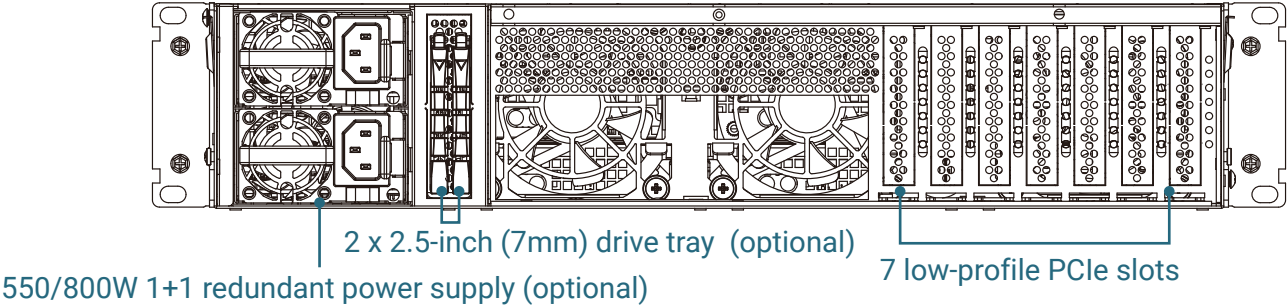

Top View

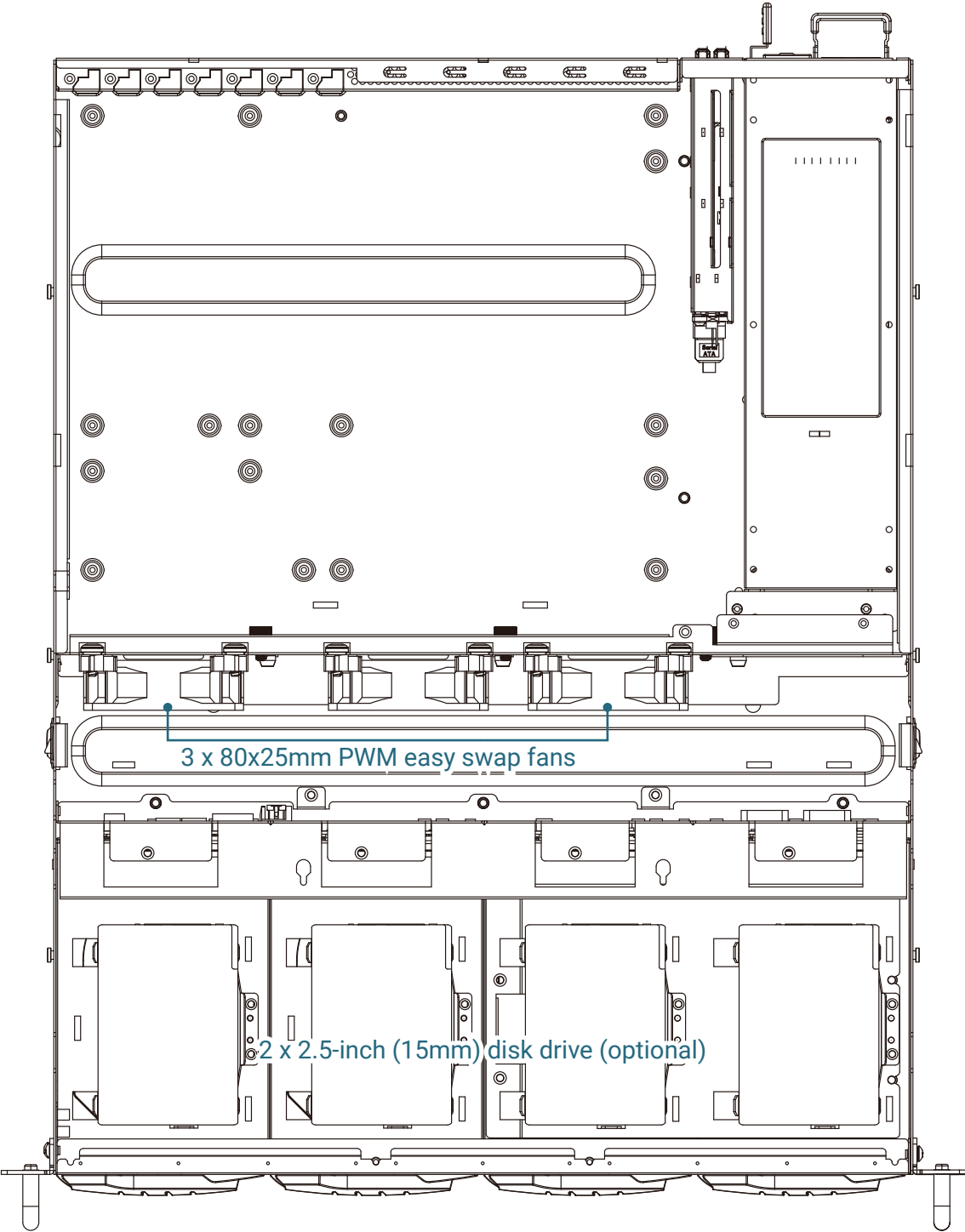

# Chapter 2. Hardware Setup

## 2.1 Top Cover

- ① Simultaneously press the release button on both sides of the chassis and push the cover toward the rear panel.
- ② Lift the top cover to complete removal.

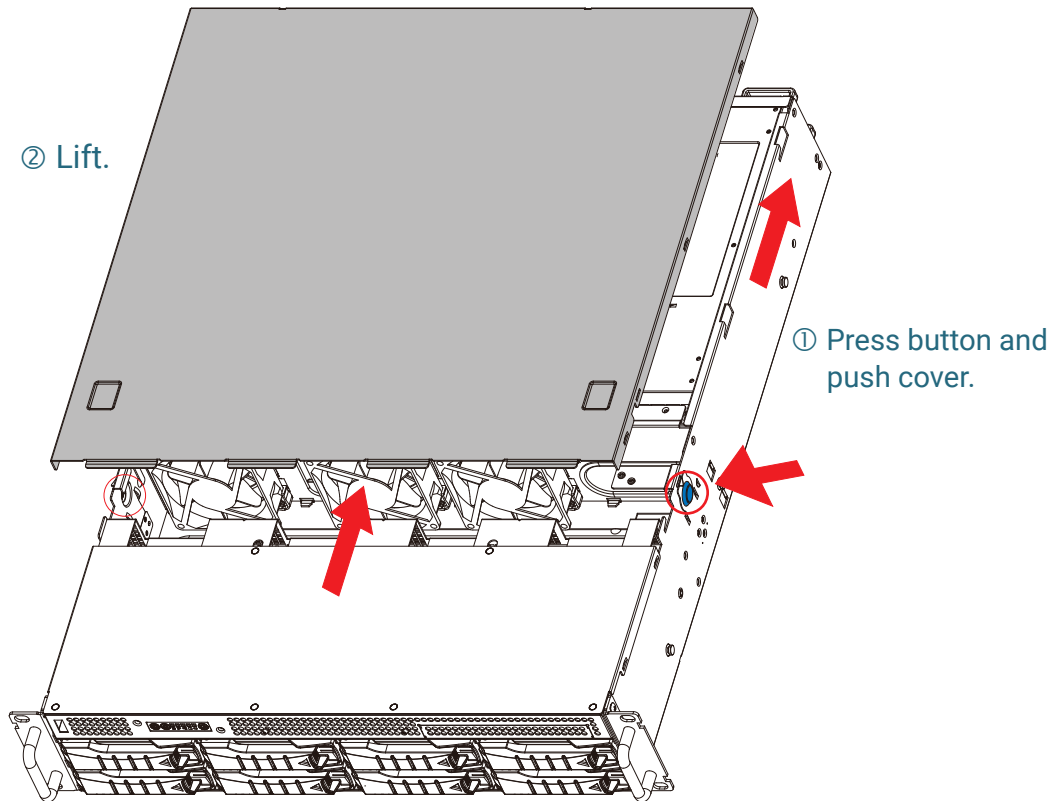

- ③ Dislodge the screws on the second top cover to uninstall the internal 2.5-inch disk drives.

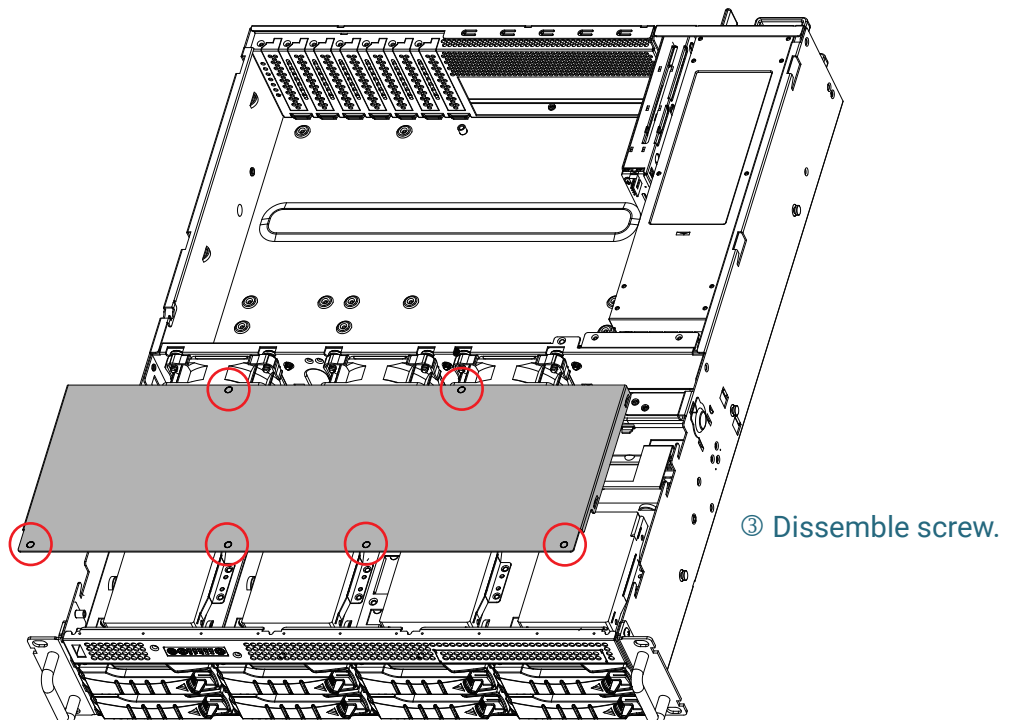

## 2.2 Power Supply Unit Module

- ① Extract the power supply unit by synchronously pressing the release button and pulling the power supply unit out of the chassis.
- ② Pull the module completely out of the chassis.
- ③ Install the new power supply unit by pushing it into the chassis. Ensure that the module is accurately inserted and locked into the chassis.

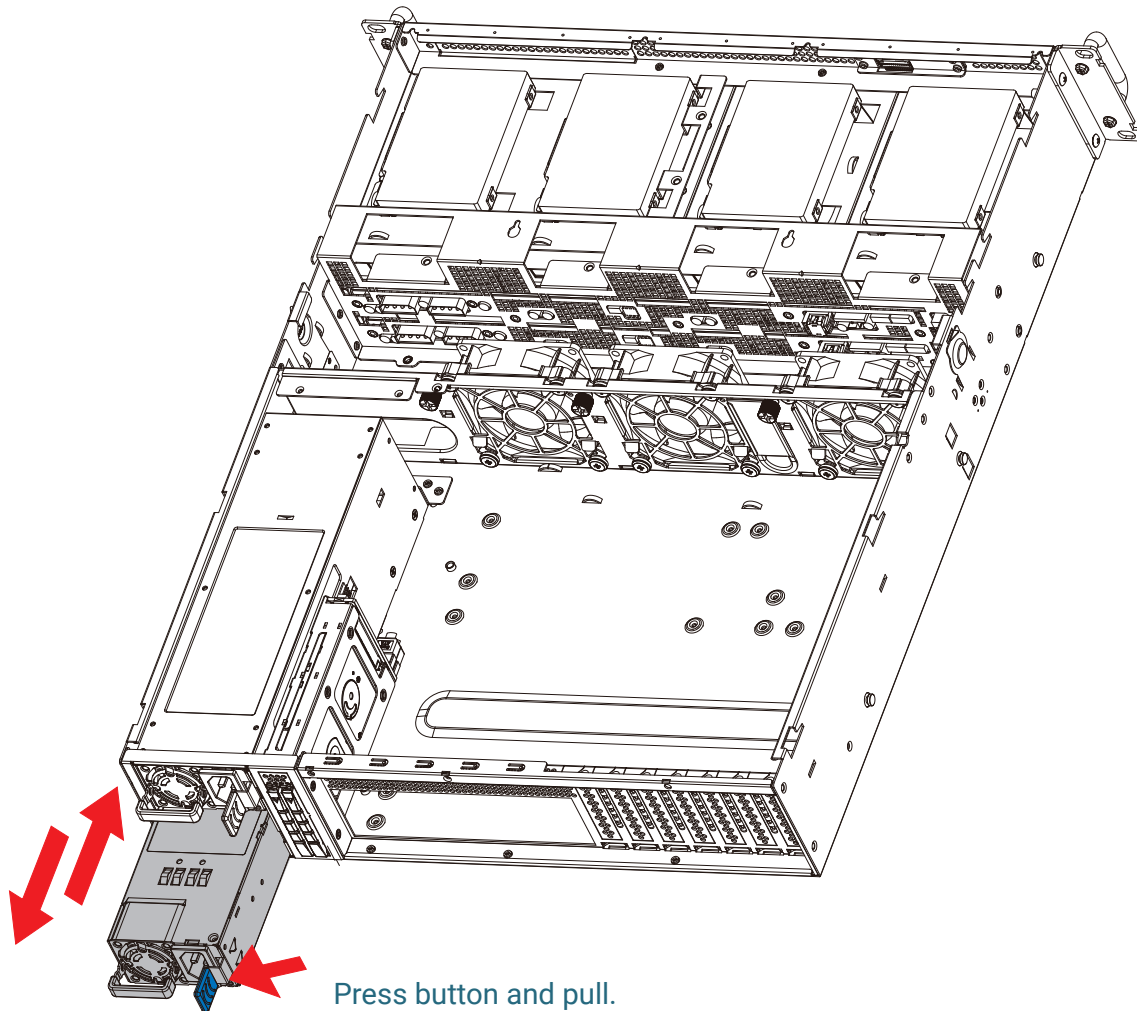

## 2.3 Fan Module

- ① Unplug the all of the cables and connectors.
- ② Lift the fan module upward. Check to carefully dislodge the rubber connectors from the attached bracket.
- ③ Insert the new fan into the chassis. Verify to align the rubber connectors with the appropriate slot in the bracket.

Disentangle fan from bracket.

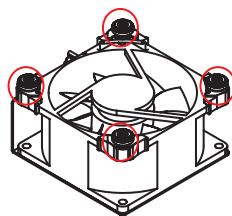
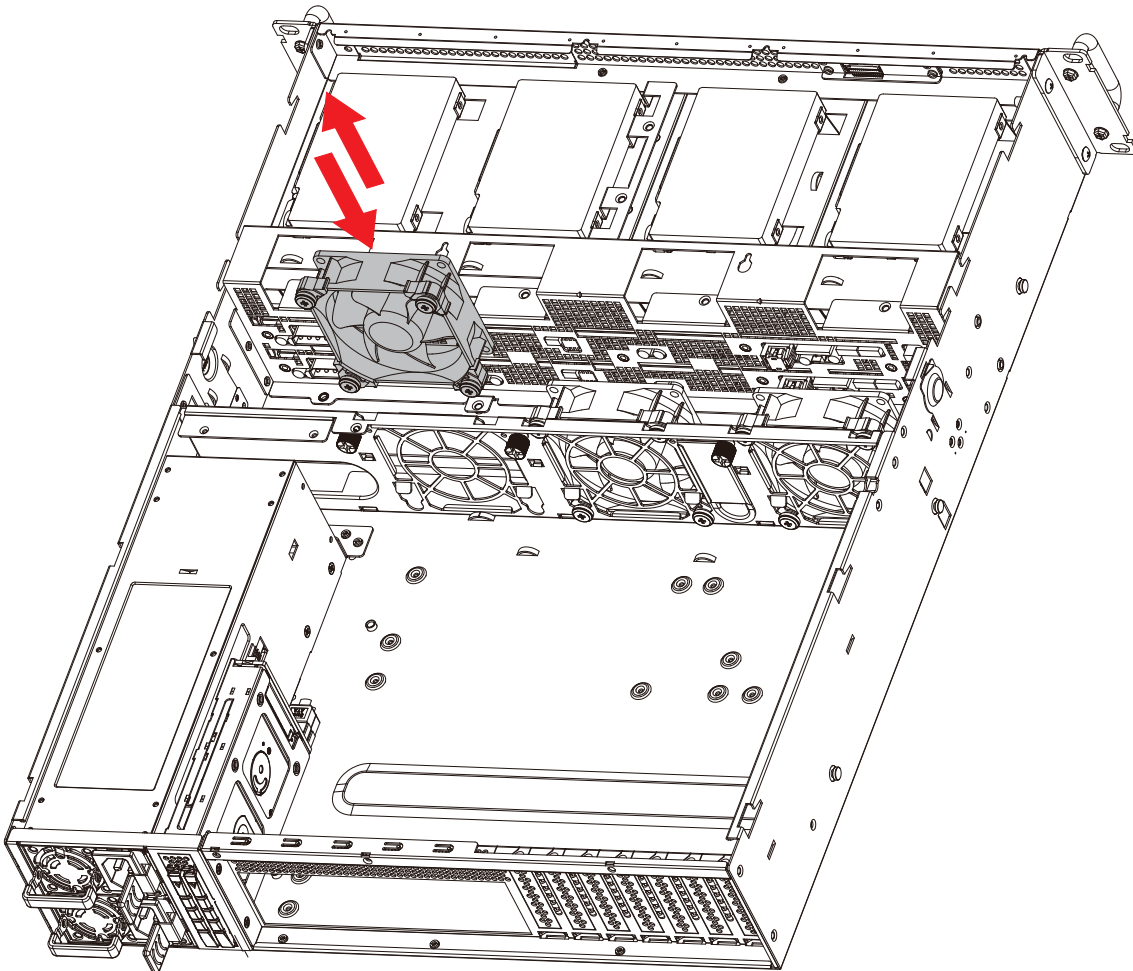

Rubber connectors

## 2.4 Hard Disk Drive

### 2.4.1 External 3.5-inch Drive

- ① Press the release button to release the tray lever.
- ② Pull the tray lever outward completely.
- ③ Pull the tray out of the chassis.

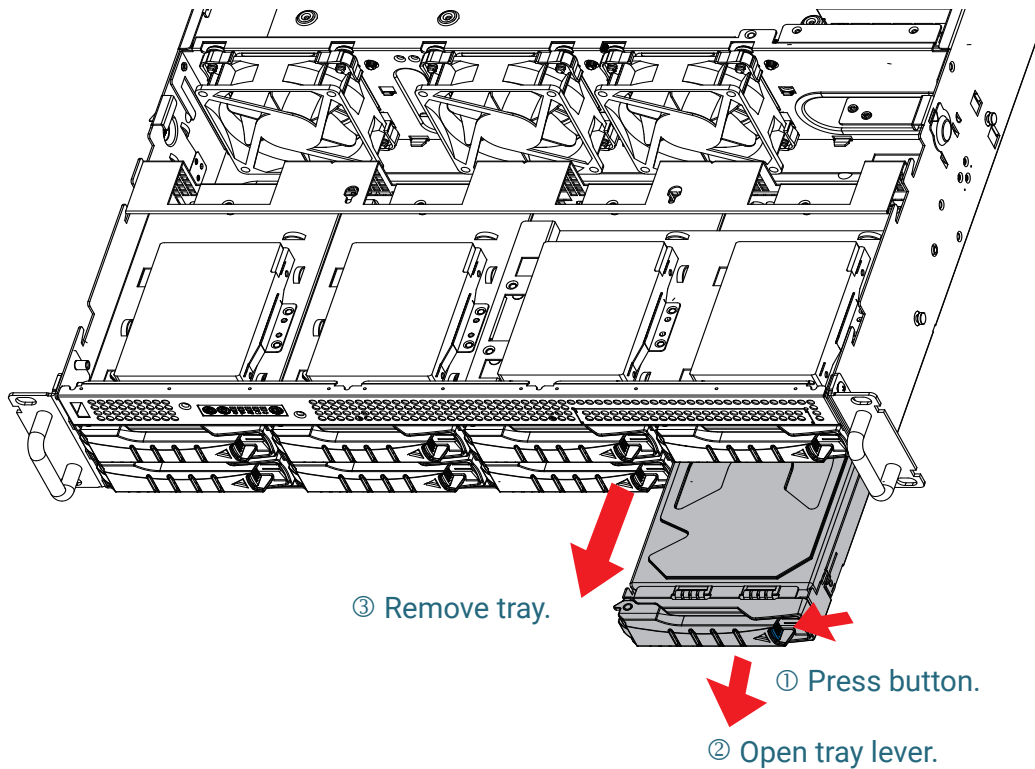

- ④ Insert the disk drive into the tray. Ensure that the dimples on the tray match the disk drive. For additional assurance, fasten the screws x 2 on the drive tray to secure the disk drive.

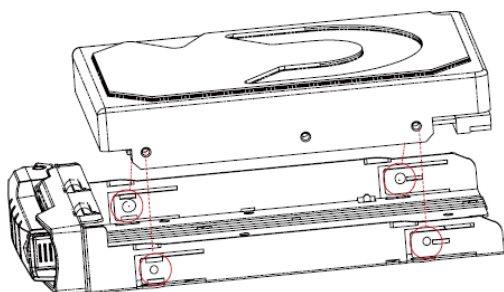

3.5" HDD dimple location

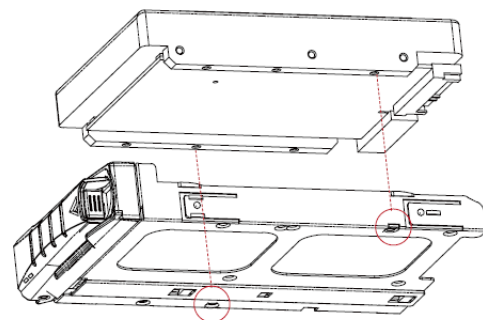

3.5" HDD screw location

### 2.4.2 External 2.5-inch Drive (Optional)

- ① Press the release button to release the tray lever.
- ② Pull the tray lever outward completely.
- ③ Pull the tray out of the chassis.

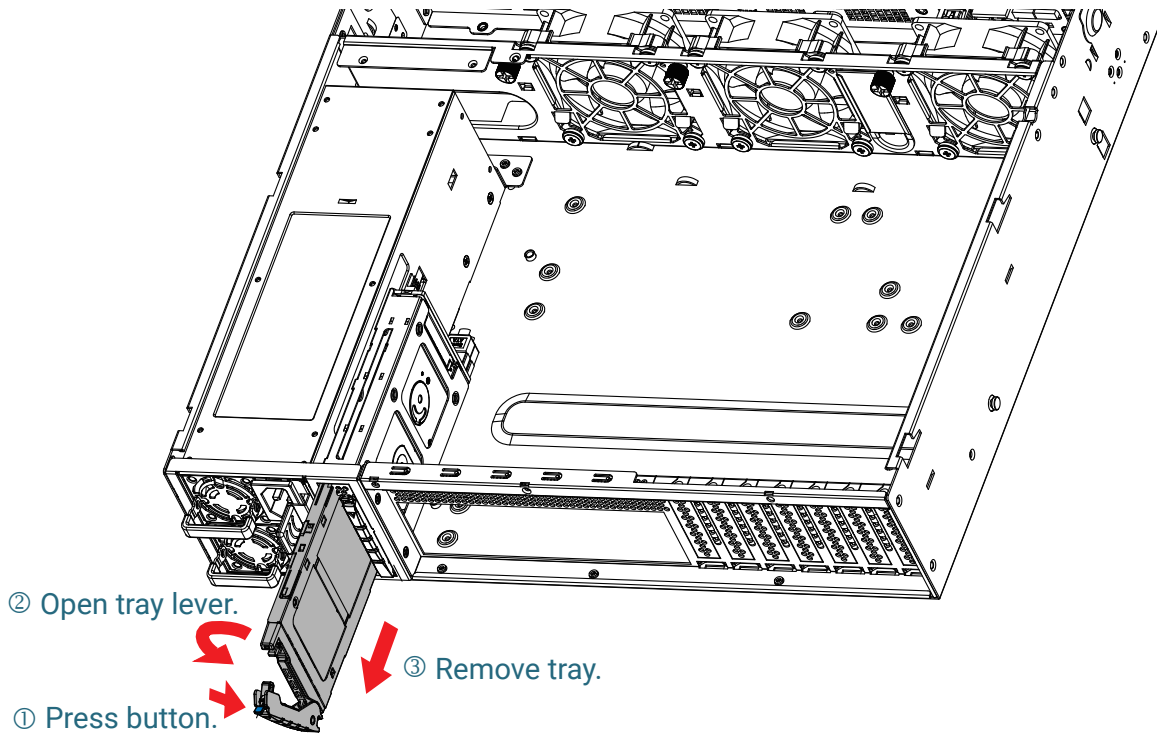

- ⑤ Insert the disk drive into the tray. Ensure that the dimples on the tray match the disk drive. For additional assurance, fasten the screws x 2 on the drive tray to secure the disk drive.

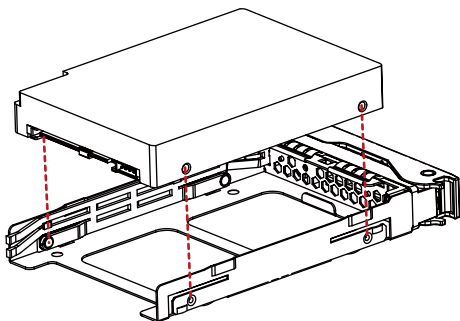

2.5" SSD dimple location

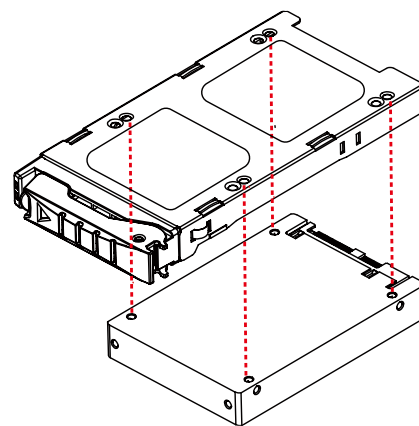

2.5" SSD screw location

### 2.4.3 Internal 2.5-inch Drive (Optional)

- ① Remove the top cover from the chassis. Please refer to 2.5 Top Cover.
- ② Lift the disk drive from the bracket holder.

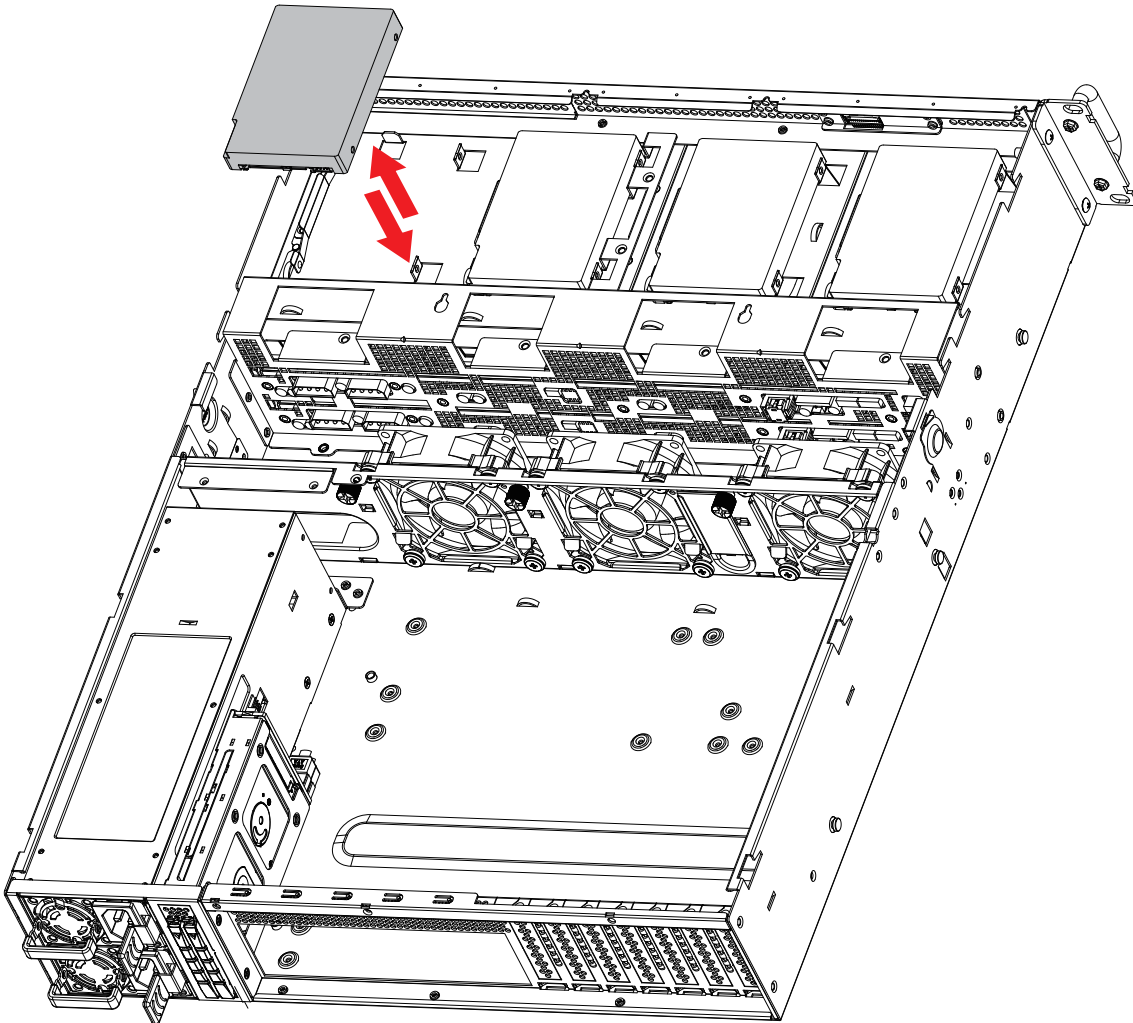

- ③ Match the dimples on the bracket holder and insert the new disk drive into the chassis.

## 2.5 HDD Backplane Module

- ① Detach the cables and hard disk drives from the backplane module.
- ② Dislodge the screws on the backplane bracket.
- ③ Lift the bracket out of the chassis.
- ④ Disassemble the bracket from the backplane to complete removal.

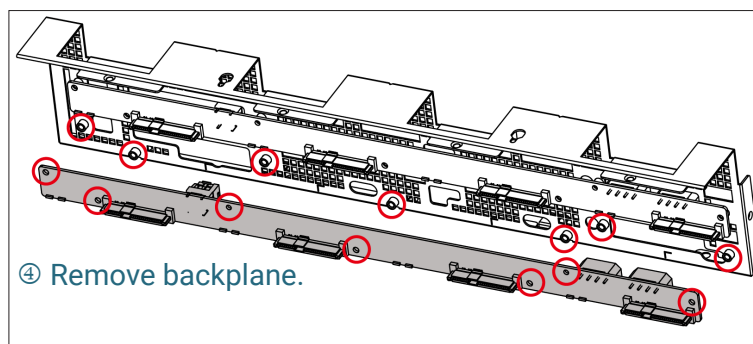
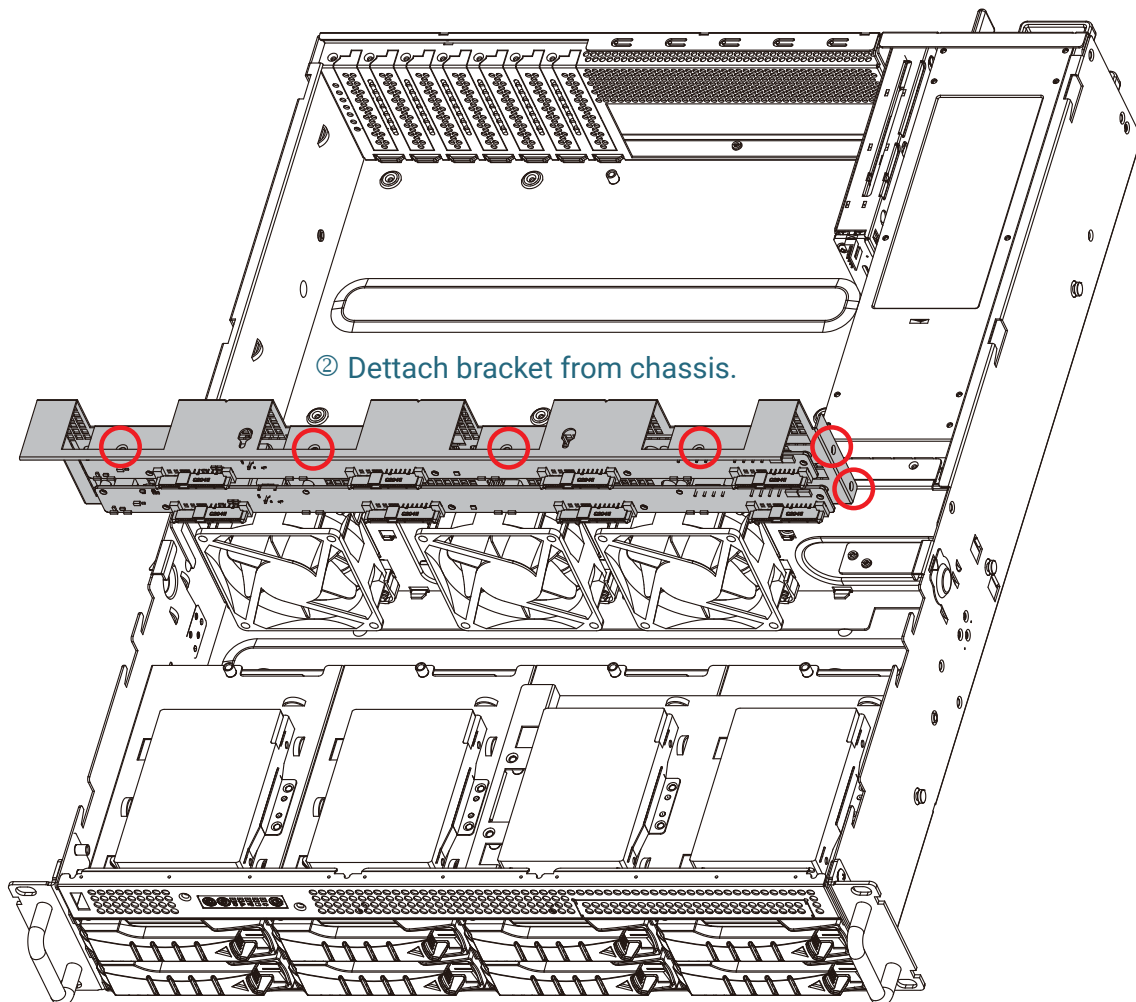

## 2.6 Slide Rail Installation

### NOTE



This section provides a basic instruction for mounting the slide rail onto the system. Tool-less rails vary per order. The rail in this manual may not exactly match the rail for your system. Please refer to the specifications or quick installation guide that came with your purchased product.

### CAUTION



The rack may tilt and fall due to incorrect installation or placed on uneven grounds. The rack must be placed in a flat surface before you begin to slide the system barebone in for servicing.

- ① Pull the inner rail out of the slide rail until it clicks.
- ② Detach the inner rail completely from the slide rail by pulling the white tab forward.

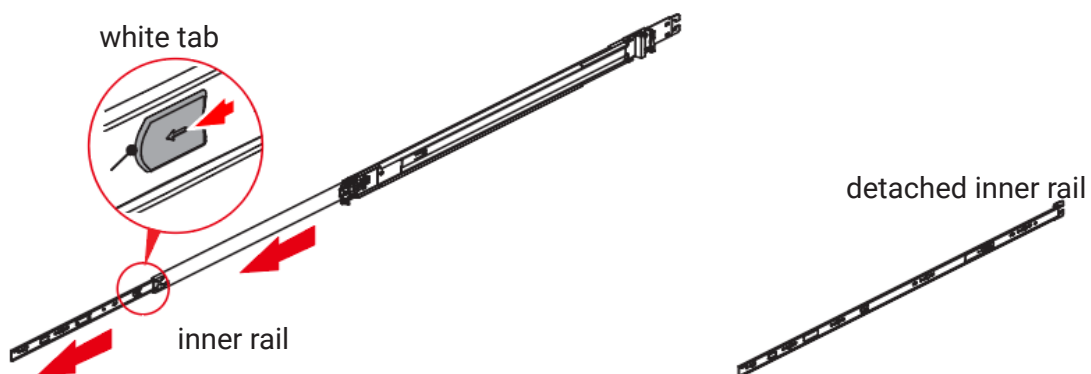

- ③ After the inner rail is dislodged, adjust the middle rail back to its original position by pushing the tab on the middle rail.



- ④ Install the inner rail onto the system barebone. Lock the keyholes and secure the screws.

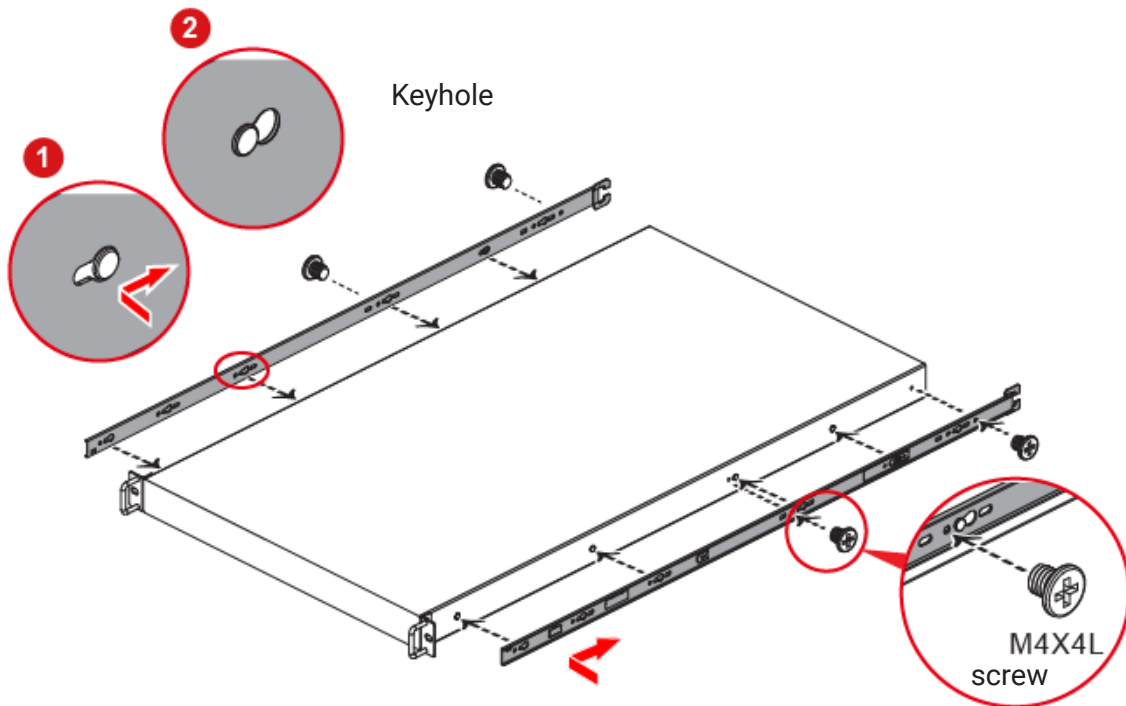

- ⑤ Continue installing the outer rail bracket to the mounting frame. Attach the outer rail assembling to the frame and press the bracket to fix the rail onto the frame. Repeat to fully mount the bracket assembly.

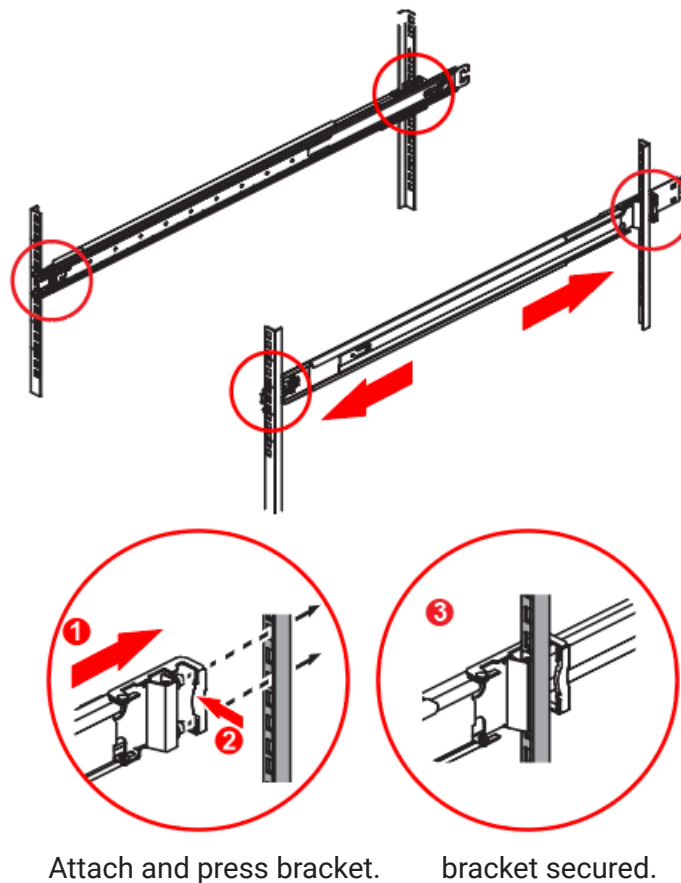

- ⑥ Pull out the middle channel until the ball bearing retainer is locked forward.

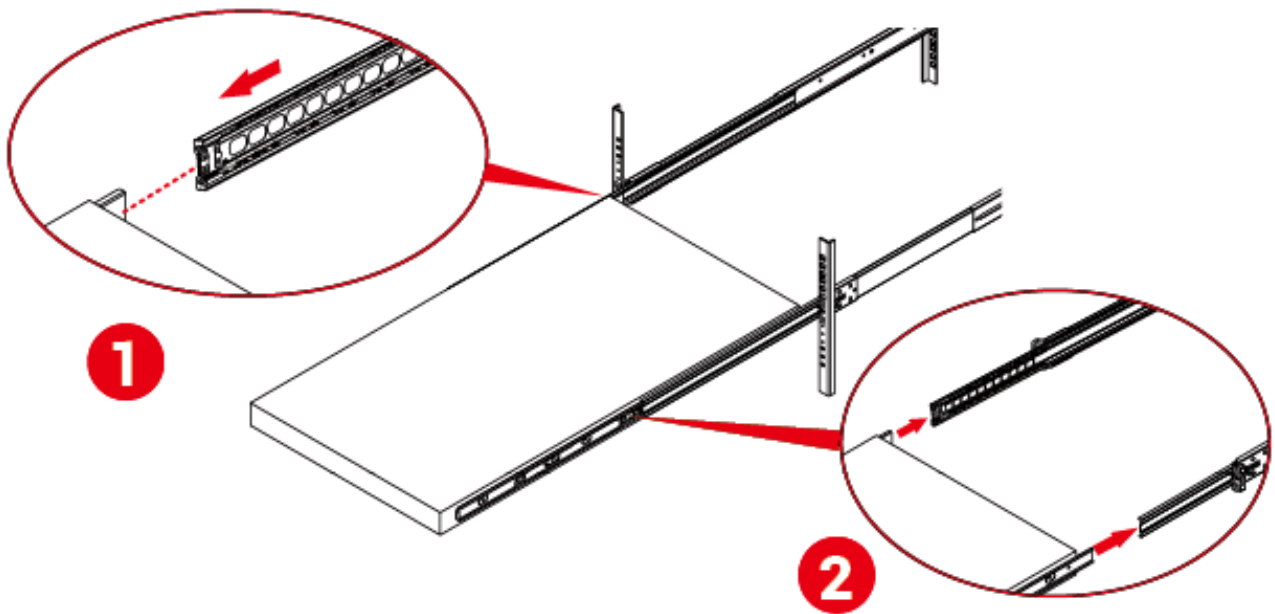
**NOTE**

Verify ball bearing retainer is locked forward.

- ⑦ Slide the release tab and push barebone into rack. Make sure the barebone is completely installed onto the rack.

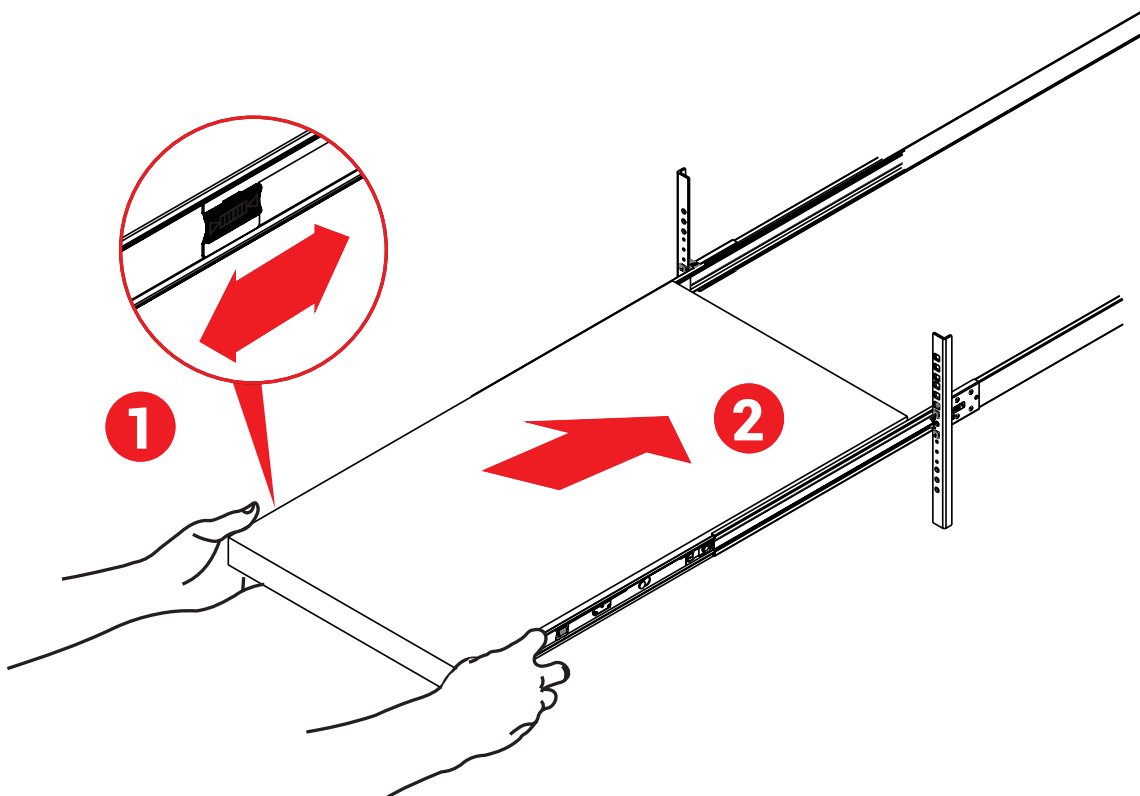

# Chapter 3. Hardware Specifications

## 3.1 Drive Backplane: 4 Bays

### 3.1.1 Placement

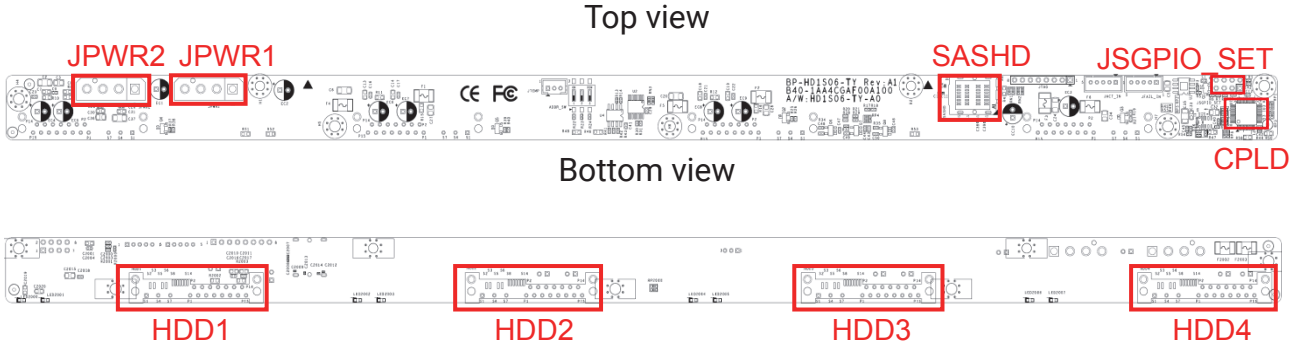

### 3.1.2 Connector and Jumper

#### Power Connector (JPWR1 & JPWR2)

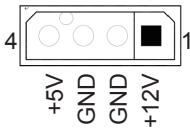

#### SGPIO

#### Function and setting

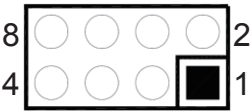

Pin	Status	Description
Pin 1, 2	Open	Disable External LED input.
	Close	Enable External LED input.
Pin 3, 4	Open	Activity LED from HDD Pin P11.
	Close	Activity LED from SGPIO.
Pin 5, 6	Open	Identify behavior according to Host.
	Close	Blinking the Identify LED behavior.
Pin 7, 8	Open	Disable SGPIO.
	Close	Enable SGPIO.

### 3.1.3 LED Indicator



HDD Activity LED	Blue (On)	HDD is present.
	Blue (Blinking)	HDD activity is detected or HDD is located.
	Off	HDD is not connected or the power is off.
HDD Fault/Status LED	Off Red (On)	HDD fault occurred or HDD is located.
	Red (Blinking)	Re-build status.
	Off	Normal.

## 3.2 Drive Backplane: 2 Bays

### 3.2.1 Placement

Top View

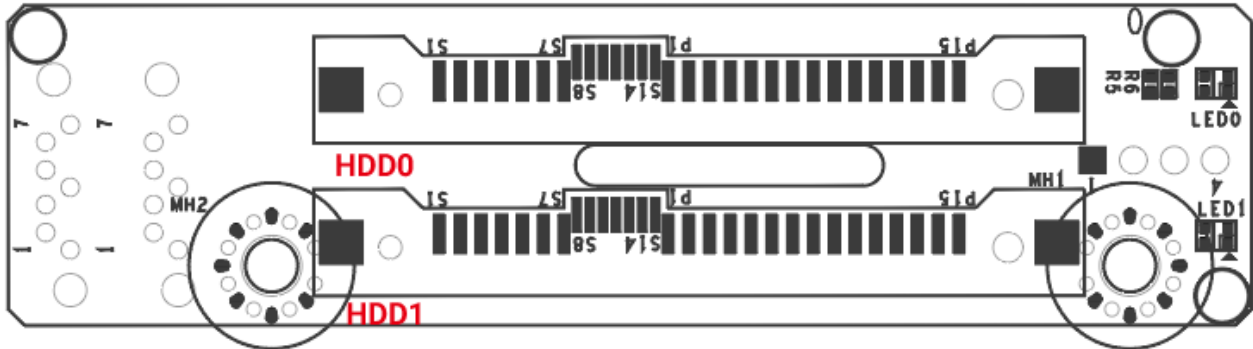

Bottom View

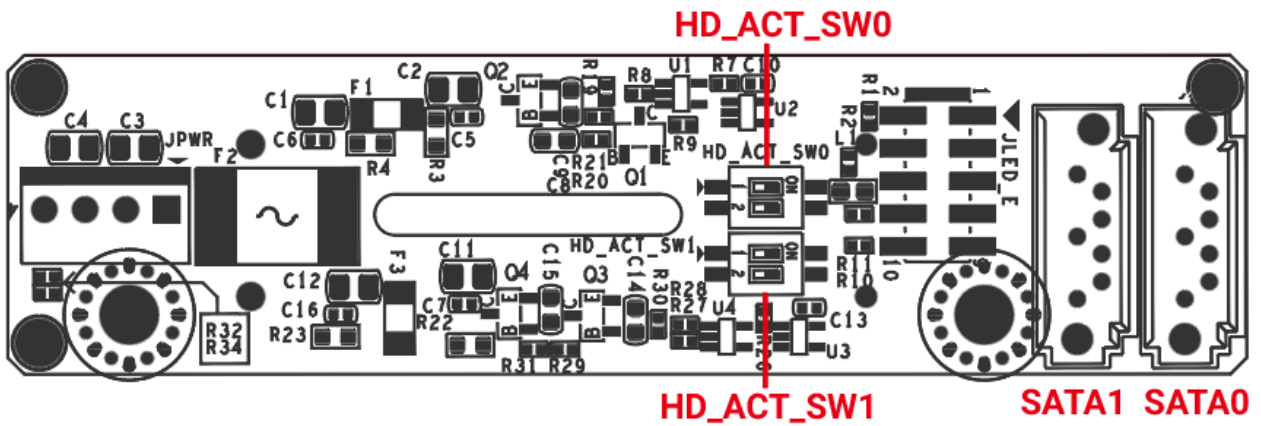

Switch Setting:

HD_ACT_SW0	pin1-2 Off
HD_ACT_SW1	pin1-2 off

# Chapter 4. Technical Support



www.aicipc.com

## Taiwan, Global Headquarters

Address: No. 152, Section 4,  
Linghang N. Rd, Dayuan District,  
Taoyuan City 337, Taiwan  
Tel: +886-3-433-9188  
Fax: +886-3-287-1818  
Sales Email: sales@aicipc.com.tw  
Support Email: support@aicipc.com

## Shanghai, China

Address: Room 1009, No. 777,  
Zhaojia Bang Rd, Shanghai 200032,  
Shanghai, China  
Tel: +86-21-54961421  
Fax +86-21-54961422 #608  
Sales Email: csales@aicipc.com.tw  
Support Email: support@aicipc.com

## Moscow, Russia

Address: No.500, 5th Floor, 5th Entrance,  
32A, Khoroshevskoye Shosse, Moscow,  
123007  
Tel: +7-4997019998  
Sales Email: support-ru@aicipc.com.tw  
Support Email: support-ru@aicipc.com.tw

## North California, United States

Address: 48531 Warm Springs  
Boulevard Suite 404 Fremont, CA  
94539, United States  
Tel: +1-510-573-6730  
Fax: +1-510-573-6729  
Sales Email: sales@aicipc.com  
Support Email: support@aicipc.com

## South California, United States

Address: 21808 Garcia Lane  
City of Industry, CA 91789,  
United States  
Toll free: +7-4997019998  
Tel: +1-909-895-8989  
Fax: +1-909-895-8989#157  
Sales Email: sales@aicipc.com  
Support Email: support@aicipc.com

## New Jersey, United States

Address: 11 Melanie Lane  
Unit #20 & 21  
East Hanover, NJ 07936, United States  
Tel: +1-973-884-8886  
Fax: +1-973-884-4794  
Sales Email: sales@aicipc.com  
Support Email: support@aicipc.com

## Houten, The Netherlands

Address: Peppelkade 58, 3992AK, Houten,  
The Netherlands  
Tel: +31-30-6386789  
Fax: +31-30-6360638  
Sales Email: sales@aicipc.nl  
Support Email: support@aicipc.com

For additional technical support or questions about trouble shooting, please contact the AIC® representative nearest to you or visit our AIC® website for more information.  
AIC® website: <https://www.aicipc.com/en/faq>.