



# RSC-2MS

## Rackmount Chassis User's Manual

# Table of Contents

<b>Preface .....</b>	<b>i</b>
<b>Safety Instructions .....</b>	<b>ii</b>
<b>About This Manual .....</b>	<b>iv</b>
<b>Chapter 1. Product Features .....</b>	<b>1</b>
1.1 Components .....	1
1.2 Specifications .....	2
1.3 Feature .....	3
<b>Chapter 2. Hardware Setup .....</b>	<b>5</b>
2.1 Top Cover .....	5
2.2 Power Supply Unit Module .....	6
2.3 Fan Module .....	7
2.4 Hard Disk Drive .....	8
2.4.1 Disk Drive: 3.5-inch.....	8
2.4.1 Disk Drive: 2.5-inch (7mm) .....	9
2.5 Slide Rail .....	10
<b>Chapter 3. Hardware Specifications.....</b>	<b>11</b>
3.1 HDD Backplane.....	11
3.1.1 Layout .....	11
3.1.2 Connector and Jumper .....	12
<b>Chapter 4. Technical Support.....</b>	<b>13</b>

### Document Release History

<b>Release Date</b>	<b>Version</b>	<b>Update Content</b>
2021 February	1	User's Manual release to public.
2021 May	1.1	Specifications update.
2021 July	1.2	Content update.
2022 June	1.3	Pictures of ME QIG update.



**Copyright© 2021 AIC®, Inc. All Rights Reserved.**

This document contains proprietary information about AIC® products and is not to be disclosed or used except in accordance with applicable agreements.

# Preface

## Copyright

No part of this publication may be reproduced, stored in a retrieval system, or transmitted in any form or by any means, electronic, mechanical, photo-static, recording or otherwise, without the prior written consent of the manufacturer.

## Trademarks

All products and trade names used in this document are trademarks or registered trademarks of their respective holders.

## Changes

The material in this document is for information purposes only and is subject to change without notice.

## Warning

1. A shielded-type power cord is required in order to meet FCC emission limits and also to prevent interference to the nearby radio and television reception. It is essential that only the supplied power cord be used.
2. Use only shielded cables to connect I/O devices to this equipment.
3. You are cautioned that changes or modifications not expressly approved by the party responsible for compliance could void your authority to operate the equipment.

## Disclaimer

AIC® shall not be liable for technical or editorial errors or omissions contained herein. The information provided is provided "as is" without warranty of any kind. To the extent permitted by law, neither AIC® or its affiliates, subcontractors or suppliers will be liable for incidental, special or consequential damages including downtime cost; lost profits; damages relating to the procurement of substitute products or services; or damages for loss of data, or software restoration. The information in this document is subject to change without notice.

# Safety Instructions

*Before you commence, please attentively read the following important discretions below. All cautions and warnings on the equipment or in the manuals should be circumspactly noted and reviewed.*

**Always ground yourself to prevent static electricity.**

請全程接地，以防止靜電。

请全程接地，以防止静电。

**Всегда заземляйте себя, чтобы избежать статического электричества.**

**Aard jezelf altijd om statische elektriciteit te voorkomen.**

- Firmly ground yourself at all times when installing or assembling the internal components of the server. Most of electronic components in the server are highly sensitive to electrical static discharge.
- Use a solid grounding wrist strap and distintively place all electronic components in static-shielded devices to prevent static. Grounding wrist straps can be purchased in any electronic supply store.
- Confirm that the power source is turned off and then disconnect the power cords from your system before performing any type of installation or manual servicing. A sudden surge of power could serverly damage the sensitive electronic components.
- Do not precipitously open the system's top cover. If you must open the cover for maintenance purposes, only a trained technician should be allowed to proceed this action. Integrated circuits on computer boards are highly sensitive to static electricity. Before operating a board or integrated circuit, touch an unpainted portion of the system unit chassis for a couple of seconds to discharge any static electricity on your body.

**Place the server in a stable environment.**

請將伺服器放置在穩定的環境中。

请将伺服器放置在穩定的環境中。

**Поместите сервер в стабильную среду.**

**Plaats de server in een stabiele omgeving.**

- Place this equipment on a stable surface when installing. A small mild drop or fall could cause fatal injury to both the equipment and the person handling the equipment.
- Please keep this equipment away from humidity to prevent vast rust and disintergration.
- Carefully and accurately mount the equipment into the rack. Uneven mechanical loading may lead to hazadous consequences.
- This equipment is to be installed for operation in an environment with maximum ambient temperature below 35°C.
- Review the environment before performing any installation or servicing. Keep the equipment away from hazardous and uneven grounds.
- This server must be installed only in Restricted Acss Locations.

**Handle equipment with care.**

請謹慎操作設備。

请谨慎操作设备。

**Обращайтесь с оборудованием осторожно.**

**Behandel de apparatuur voorzichtig.**

- Do not cover the openings of the system. The openings on the system are for air convection, which intentionally protect the equipment from overheating.
- Never pour any liquid into ventilation openings of the system. This could cause catastrophic fire or electrical shock.

- Ensure that the voltage of the power source is within the specification on the label when connecting the equipment to the power outlet. The current load and output power of loads must be within the specification.
- This equipment must be firmly connected to reliable grounding before usage. Pay special attention to power supplied other than direct connections, e.g. using of power strips.
- Place the power cord out of the way of foot traffic. Do not place anything over the power cord. The power cord must be rated for the product, voltage and current marked on the product's electrical ratings label. The voltage and current rating of the cord should be greater than the voltage and current rating marked on the product.

**Pay attention to hardware maintenance.**

注意硬體維護。

注意硬体维护。

**Обратите внимание на обслуживание оборудования.**

**Besteed aandacht aan hardware-onderhoud.**

- If the equipment is not used for a long time, disconnect the equipment from mains to avoid being damaged by transient over-voltage.
- Module and drive bays must not be empty. They must have a dummy cover.
- Never open the equipment without professional assistance. For safety reasons, only qualified service personnel should open the equipment.
- If one of the following situations arise, the equipment should be checked and tested by service personnel:
  1. The power cord or plug is damaged.
  2. Liquid has penetrated the equipment.
  3. The equipment has been exposed to moisture.
  4. The equipment does not work well or will not work according to its user manual.
  5. The equipment has been dropped and/or damaged.
  6. The equipment has obvious signs of breakage.
  7. Please disconnect this equipment from the AC outlet before cleaning. Do not use liquid or detergent for cleaning. The use of a moisture sheet or cloth is recommended for cleaning.



**CAUTION**

The equipment intended for installation should be placed in Restricted Access Location.



**CAUTION**

There will be a risk of explosion if battery is replaced by an incorrect type. Dispose of used batteries according to the instructions. After performing any installation or servicing, make sure the enclosure is correct in position before turning on the power.



**CAUTION**

This unit may have more than one power supply. Disconnect all power sources before maintenance to avoid electric shock.



# About This Manual

Thank you for selecting and purchasing RSC-2MS

This user's manual is provided for professional technicians to perform easy hardware setup, basic system configurations, and quick software startup. This document pellucidly presents a brief overview of the product design, device installation, and firmware settings for 2MS Rackmount Chassis. For the latest version of this user's manual, please refer to the AIC® website: RSC-2MS is a flexible rackmount storage chassis with tool-less design. This product supports hot swappable HDDs and easy swap fans. For more information about our product, please visit our website at <https://www.aicpc.com/tw/productdetail/51227>.

## **Chapter 1 Product Features**

This chapter delivers the overall layout of the product, including the fundamental components of the rackmount chassis, design specifications, and noteworthy features.

## **Chapter 2 Hardware Setup**

This chapter displays an easy installation guide for assembling the chassis. Utmost caution for proceeding to set up the hardware is highly advised.

## **Chapter 3 Hardware Specifications**

This chapter elaborates the overall layout of the hardware design, including multifarious connectors, jumpers, and LED descriptions.

## **Chapter 4 Technical Support**

For more information or suggestion, please contact the nearest AIC® corporation representative in your district or visit the AIC® website: <http://www.aicpc.com/en/index>. It is our greatest honor to provide the best service for our customers.

# Chapter 1. Product Features

RSC-2MS is a flexible rackmount storage chassis with tool-less design. This product supports hot swappable disk drives and easy swap fans. For more information about our product, please visit our website at <http://www.aicipc.com/en/index>.

Before removing the subsystem from the shipping carton, visually inspect the physical condition of the shipping carton. Exterior damage to the shipping carton may indicate that the contents of the carton are damaged. If any damage is found, do not remove the components; contact the dealer where the subsystem was purchased for further instructions. Before continuing, first unpack the subsystem and verify that the number of components in the shipping carton is accurate and in good condition.

## 1.1 Components

This product contains the components listed below. Please confirm the number and the condition of the components before installation.

- System barebone (includes power supply, fan & hard disk drive tray)
- Power cord (vary per region)
- Slide rail x 1 set (optional)

Pre-installed into the system		Number
✓	800W redundant PSU PMBus 1.2 80+ Platinum	1+1
✓	3.5-inch internal hot swap drive bays	24
✓	60x38mm PWM fans	4
Accessory Item		Number
✓	2 x 2.5-inch HDD bottom screw : F(+),M3X4L,NI	8
✓	screw for PCIe card : K(+),632X5L,NI	10
✓	ASS'Y, motherboard left spacer 4MM KITS: MCB	2
✓	Hex standoff: M3*3.9L-6#32*2L	16
✓	Motherboard screw: RW(+),M3X4L,NI	20
✓	Front board EPE foam: 563*420*105H	1
✓	Rear board EPE foam: 563*465*105H	1
✓	Front tray EPE foam: 563*300*145H	1
✓	Rear tray EPE foam: 563*300*145H	1
✓	EPE PAD for heatsink box: 130*115*100H	1
✓	EPE PAD: 130*100*50T	2
✓	Power cord	vary per region
BTO	33-inch tool-less slide rail assembly	1

**Product specifications and features are subject to change without prior notice.**

## 1.2 Specifications

<b>Dimensions</b> (W x D x H)	mm : 438 x 838 x 88		
	inches : 17.2 x 33 x 3.46		
<b>Industry Standard</b>	EIA-RS310D		
<b>Material</b>	SGCC		
<b>Color</b>	Front Panel : Black		
<b>Cooling</b>	4 x 60x38mm PWM fans		
<b>Power Supply</b>	800W 1+1 redundant PSU PMBus 1.2 80+ Platinum		
<b>Expansion Slots</b>	7 low profile		
<b>Front Panel</b>	System power switch and system reset switch		
<b>LED Indicators</b>	System power, HDD, LAN 1 and LAN 2		
<b>System Board</b>	Up to 12" x 9.6" ATX M/B		
<b>Drive Bays</b>	Internal	3.5" hot swap	24
	External	2.5"	2 (7mm SSD) (optional)

<b>Backplanes</b>	8 x 4-port SATA/SAS backplanes with SFF-8643 connectors	
<b>Storage Temperature</b>	0°C(32°F) ~ 50°C(122°F)	
<b>Humidity</b>	5%~95% non-condensing	
<b>Gross Weight</b>	(w/ PSU & Rail)	kgs : 31
		lbs : 68.35
<b>Packaging Dimensions</b>	(W x D x H)	mm : 602 x 1116 x 292
		inches : 23.7 x 45 x 11.5
<b>Cubic Feet</b>	7.9	
<b>Container Load Quantity</b>	20'	120
	40'	250
	40' H	300
<b>Mounting</b>	Standard	33" slide rail



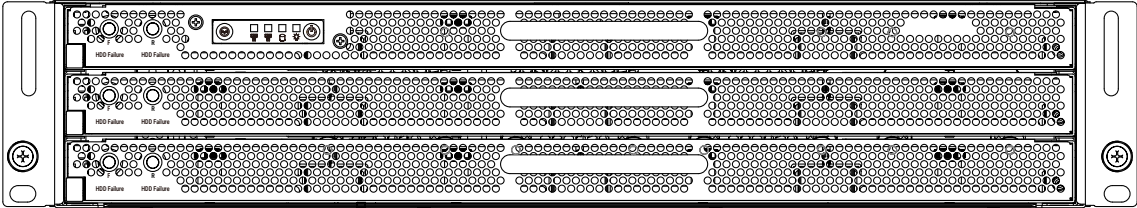

- Tool-less design, support quick installation and maintenance (HDD)
- High-density storage server solution in 2U
- 3 drawers to load up to 24 hot swap drives
- Tool-less 3.5" & 2.5" drive trays
- Silicon gaskets to absorb vibration from the sides of the drives

# 1.3 Feature

## Front Panel



System Button and LED Indicator

Item	Description	Item	Description
	System power button		System power LED
	Drive activity LED		LAN1 & LAN2 LED
	System reset button		

## Rear Panel

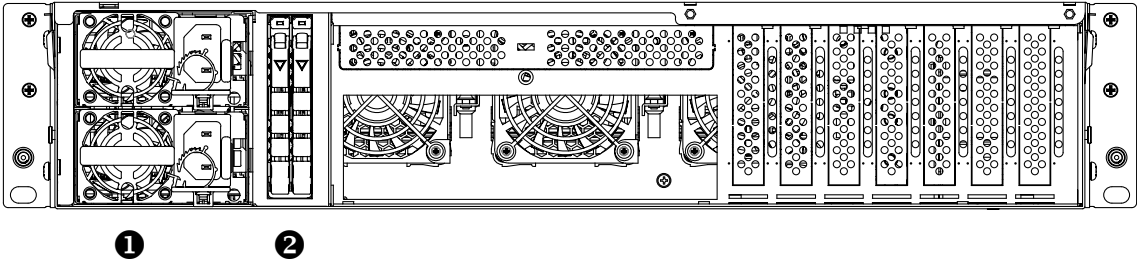

Item	Content	Description
1	PSU socket	800W 1+1 redundant PSU PMBus 1.2 80+ Platinum
2	Disk drive tray	2.5" (7mm) disk drive bay (BTO)

Top View

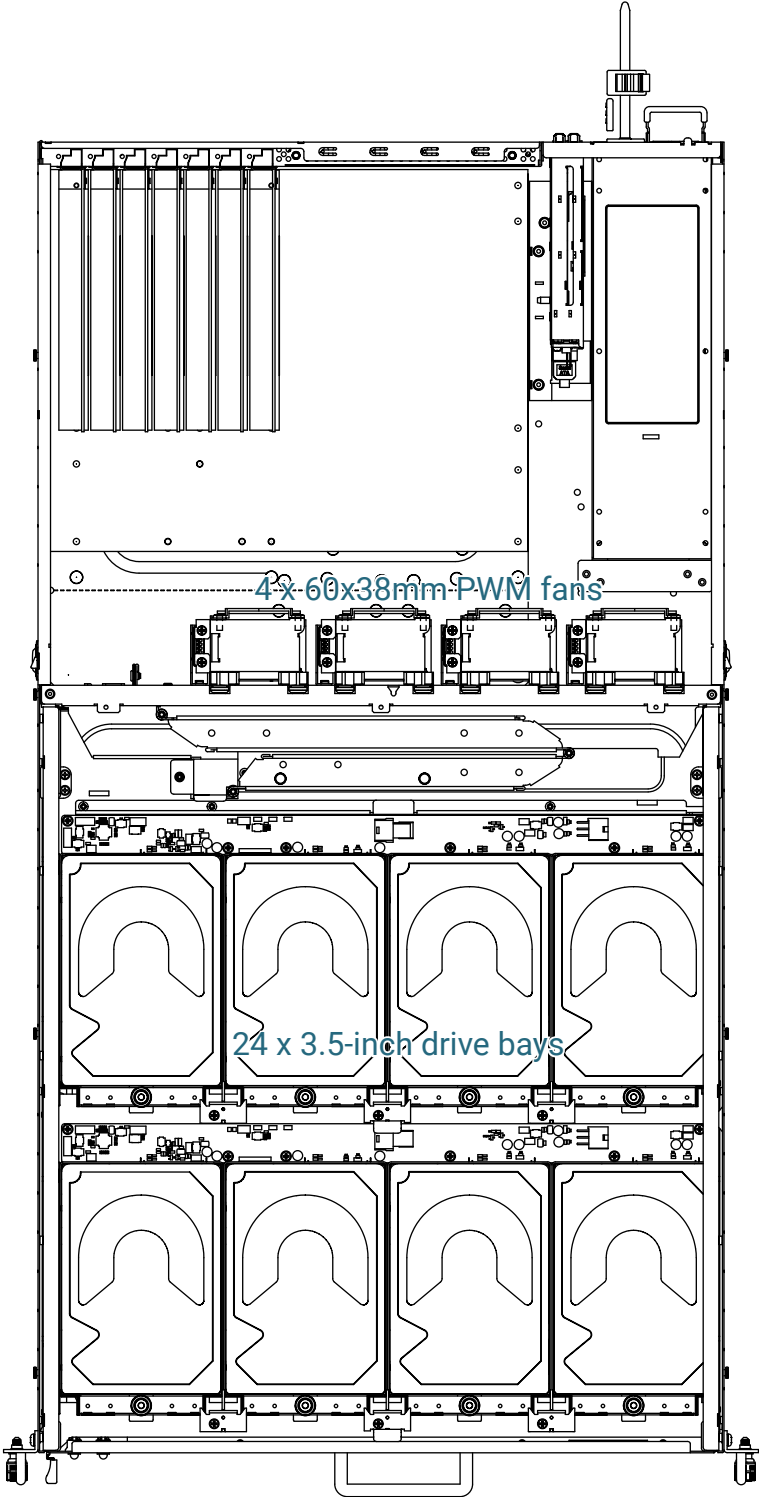

 **NOTE**  
Motherboard is not included in this product.

# Chapter 2. Hardware Setup

## 2.1 Top Cover

- ① Push the release button on both sides of the chassis and push the cover towards the rear panel.
- ② Lift the top cover upward.

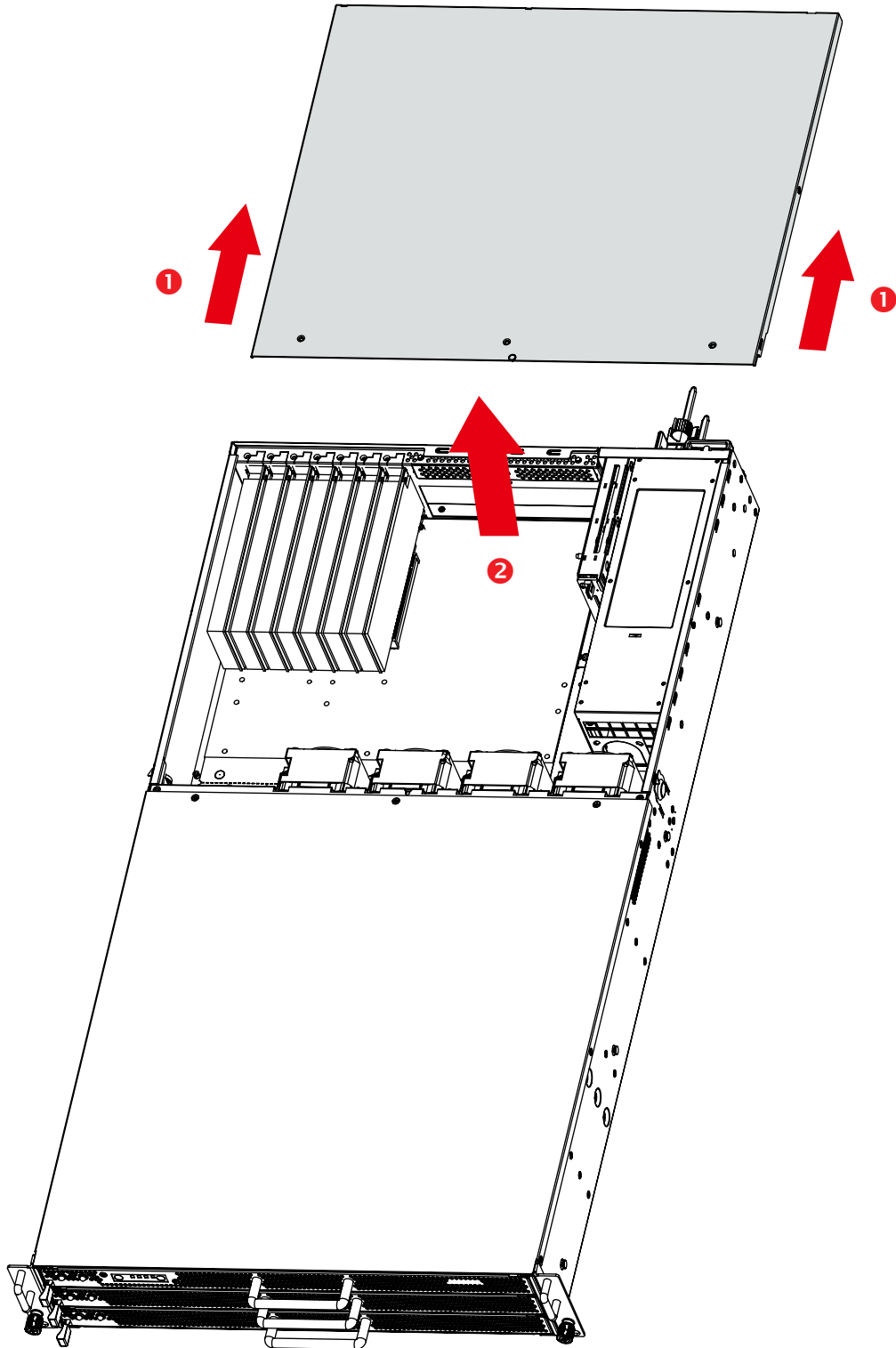

## 2.2 Power Supply Unit Module

- ① Remove the power supply unit by pushing the ejector and pull the power supply unit outward.
- ② Pull the module out of the chassis.
- ③ Push the replaced module into the chassis to complete installation. Ensure that the module is accurately inserted and locked into the chassis.

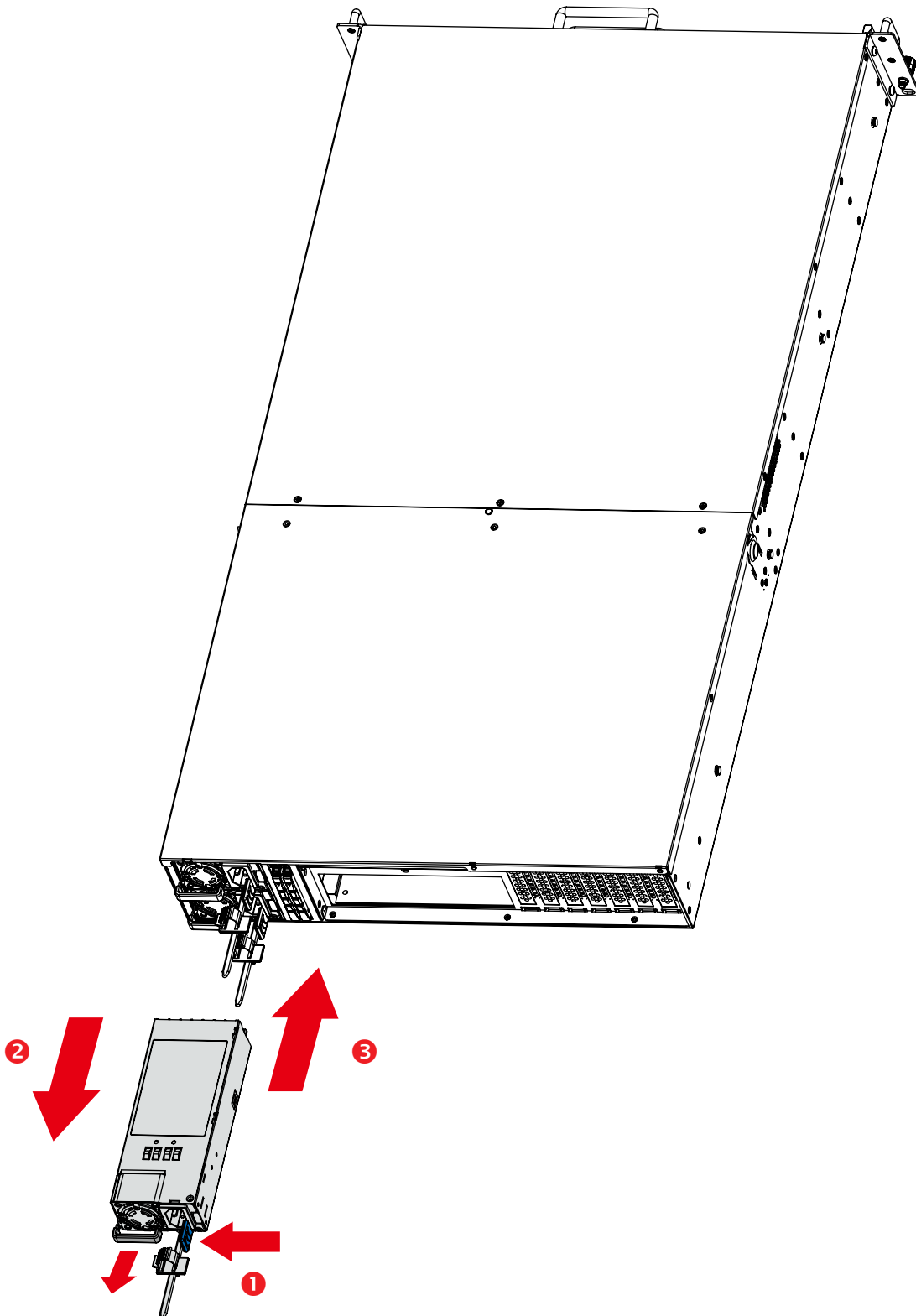

## 2.3 Fan Module

- ① Remove the top cover of the chassis. Please refer to [Section 2.1](#).
- ② Unplug the cables and connectors.
- ③ Remove the fan module by dislodging the screw on the fan bracket.
- ④ Lift the fan module upward. Check to carefully dislodge the rubber connectors from the attached bracket.
- ⑤ Insert the replaced fan into the chassis. Verify to align the rubber connectors with the appropriate slot in the bracket.
- ⑥ Secure the screw to complete installation.

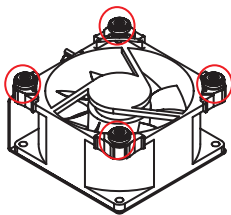

Rubber connectors

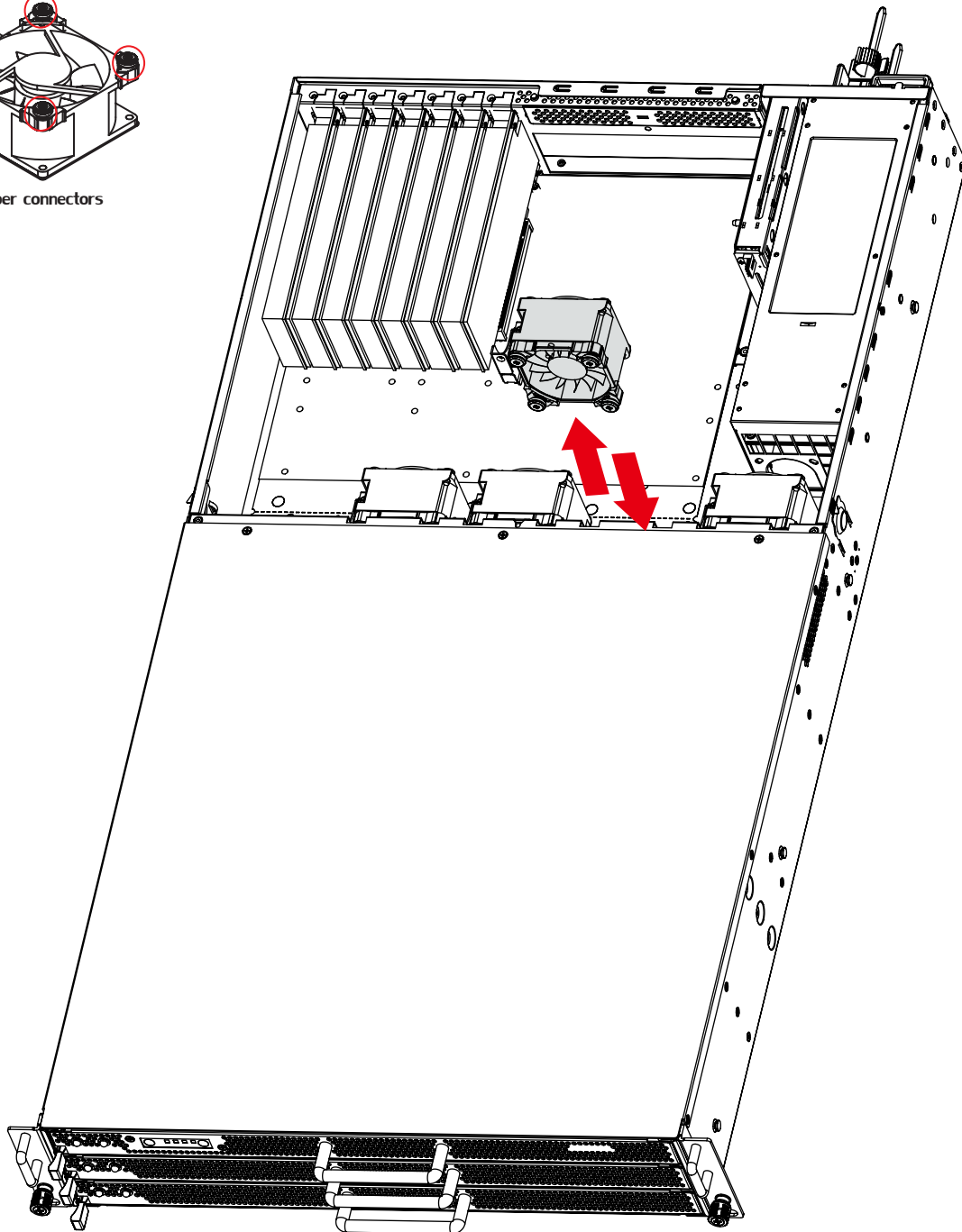

## 2.4 Hard Disk Drive

### 2.4.1 Disk Drive: 3.5-inch

- ① Press the release button on the tray and pull.
- ② Pull the tray out of the chassis.
- ③ Remove the HDD by pushing the plunger inward and lifting the HDD from the chassis.
- ④ Insert the replaced HDD into the chassis. Ensure that the HDD is aligned and locked into the tray.
- ⑤ Push the tray into the chassis to complete installation.

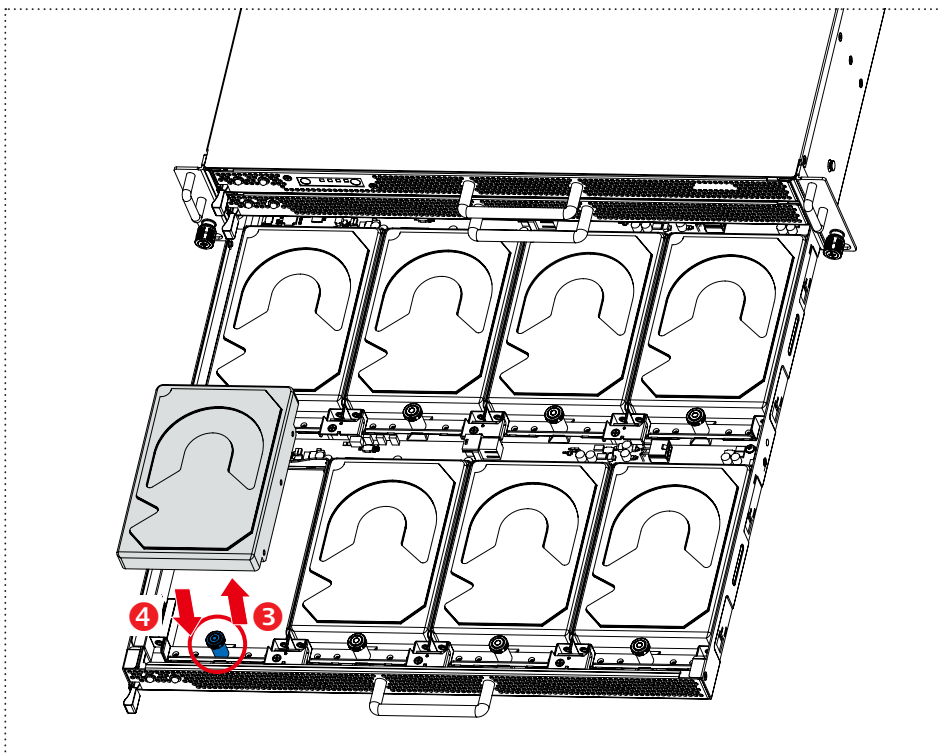
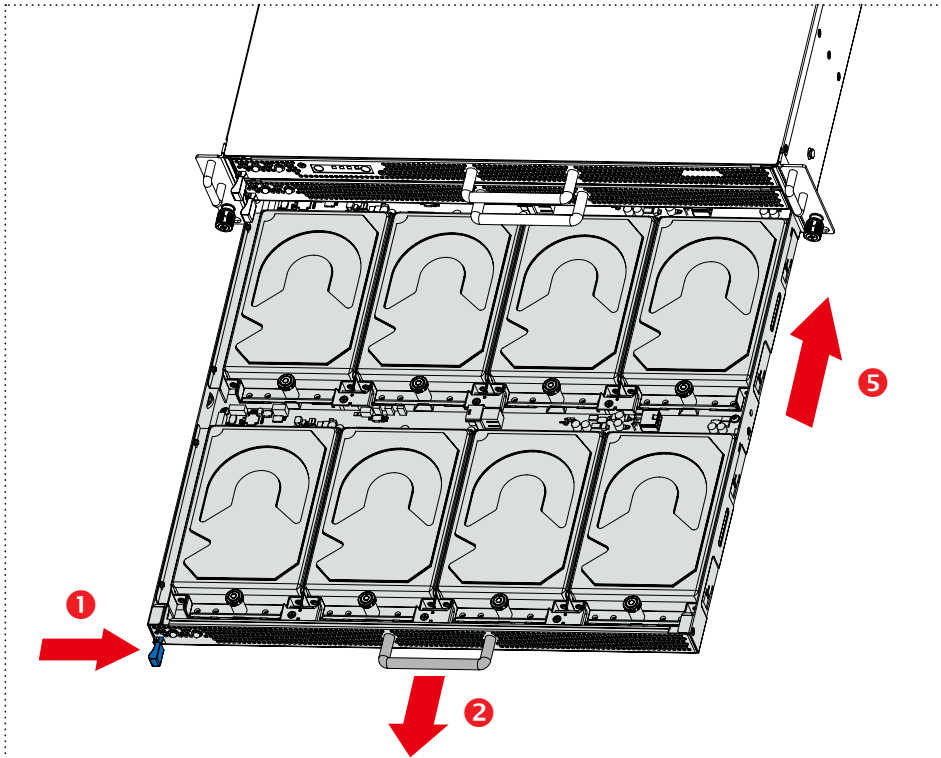

### 2.4.1 Disk Drive: 2.5-inch (7mm)

- ① Press the release button the tray lever to loosen the lever.
- ② Pull the tray lever outward completely.
- ③ Pull the tray out of the system.

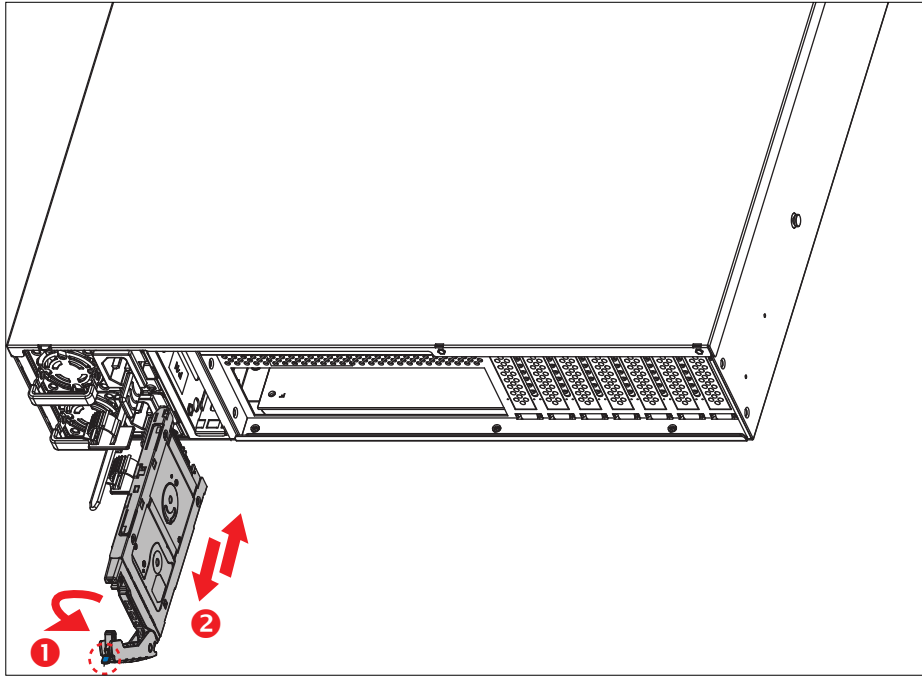

- ④ Insert the hard disk drive into the tray. Ensure that the dimples on the tray match the hard disk drive. For additional assurance, fasten the screws x 4 on the drive tray to secure the hard disk drive.

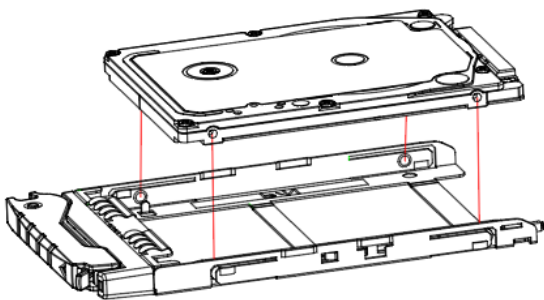

Dimple location

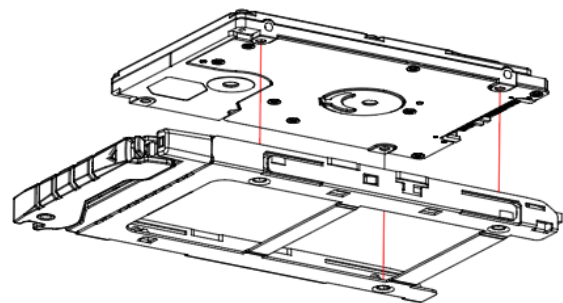

Screw location

## 2.5 Slide Rail

### NOTE



Tool-less rails vary per order. The rail in this manual may not exactly match the rail for your system. Please refer to the specifications or quick installation guide that came with your purchased product.

### CAUTION



The rack may tilt and fall due to incorrect installation or placed on uneven grounds. The rack must be placed in a flat surface before you begin to slide the system barebone in for servicing.

### NOTE



The product installation position is less than 1 meter in height from the supporting surface.

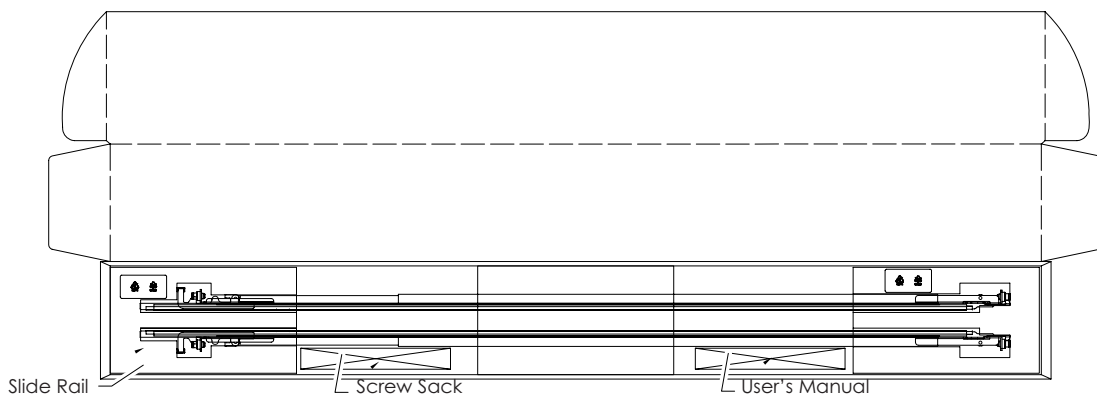
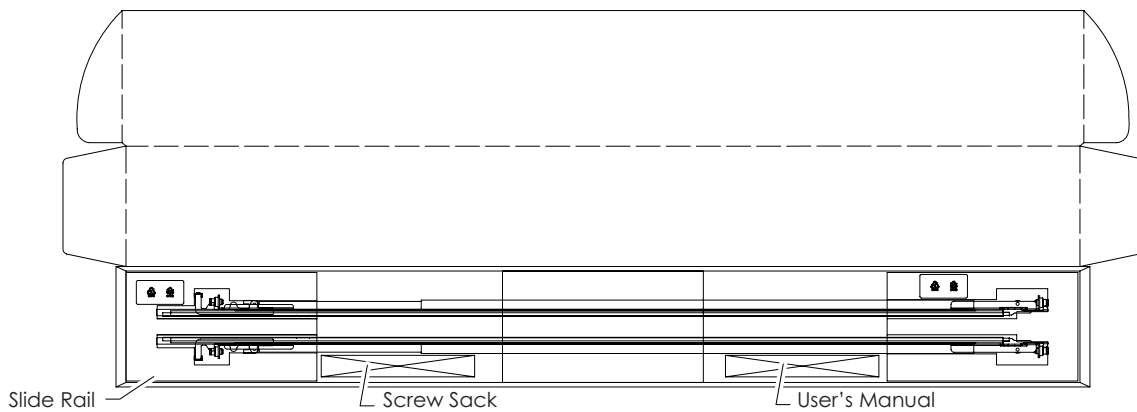

# Chapter 3. Hardware Specifications

This chapter illustrates a detailed instruction guide on hardware specifications.

## 3.1 HDD Backplane

### 3.1.1 Layout

Top view

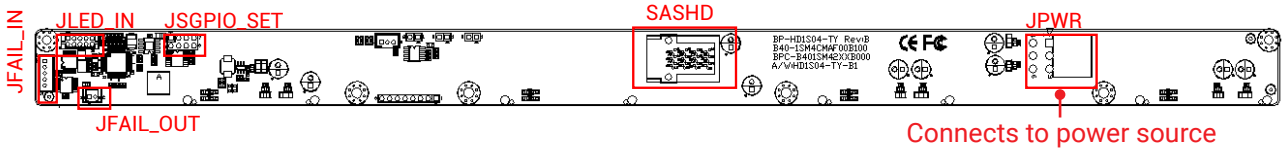

Bottom view

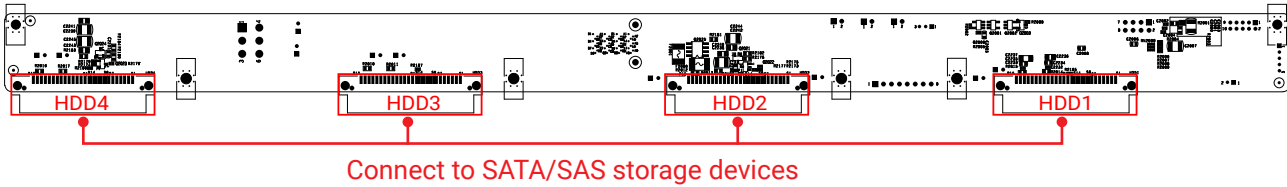

### 3.1.2 Connector and Jumper

#### Power Connector (JPWR)

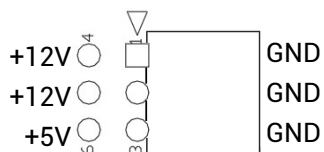

#### Status LED Header (JLED\_IN)

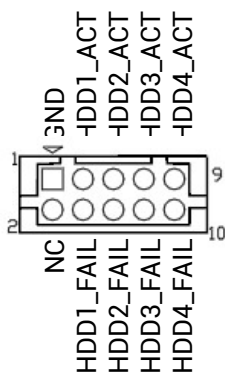

#### Fail LED Header (JFAIL\_OUT)

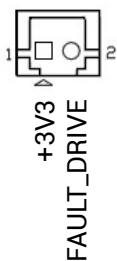

#### Fail LED Status Header (JFAIL\_IN)

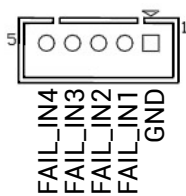

#### SGPIO Jumper Function and Setting

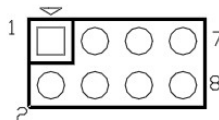

Pin	Status	Description
1,2	Open	Disable External Access LED input.
	Close	Enable External Access LED input.
3,4	Open	Access LED from HDD Pin P11.
	Close	Access LED from SGPIO.
5,6	Open	Identify behavior according to Host.
	Close	Identify LED blinking behavior.
7,8	Open	Disable SGPIO.
	Close	Enable SGPIO.

# Chapter 4. Technical Support



[www.aicipc.com](http://www.aicipc.com)

## Taiwan, Global Headquarters

**Address:** No. 152, Section 4,  
Linghang N. Rd, Dayuan District,  
Taoyuan City 337, Taiwan  
**Tel:** +886-3-433-9188  
**Fax:** +886-3-287-1818  
**Sales Email:** [sales@aicipc.com.tw](mailto:sales@aicipc.com.tw)  
**Support Email:** [support@aicipc.com](mailto:support@aicipc.com)

## Shanghai, China

**Address:** Room 215, Building 4, No.471  
Guiping Road, Xuhui District, Shanghai City,  
200233 China  
**Tel:** +86-21-54961421  
**Sales Email:** [sales@aicipc.com.cn](mailto:sales@aicipc.com.cn)  
**Support Email:** [support@aicipc.com](mailto:support@aicipc.com)

## Moscow, Russia

**Address:** No.500, 5th Floor, 5th Entrance,  
32A, Khoroshevskoye Shosse, Moscow,  
123007  
**Tel:** +7-4997019998  
**Sales Email:** [support-ru@aicipc.com.tw](mailto:support-ru@aicipc.com.tw)  
**Support Email:** [rma.russia@aicipc.com.tw](mailto:rma.russia@aicipc.com.tw)

## North California, United States

**Address:** 48531 Warm Springs  
Boulevard Suite 404 Fremont, CA  
94539, United States  
**Tel:** +1-510-573-6730  
**Sales Email:** [sales@aicipc.com](mailto:sales@aicipc.com)  
**Support Email:** [support@aicipc.com](mailto:support@aicipc.com)

## South California, United States

**Address:** 21808 Garcia Lane  
City of Industry, CA 91789,  
United States  
**Toll free:** + 1-866-800-0056  
**Tel:** +1-909-895-8989  
**Fax:** +1-909-895-8999  
**Sales Email:** [sales@aicipc.com](mailto:sales@aicipc.com)  
**Support Email:** [support@aicipc.com](mailto:support@aicipc.com)

## New Jersey, United States

**Address:** 322 Route 46 West Suite 100  
Parsippany, NJ 07054 United States  
**Tel:** +1-973-884-8886  
**Fax:** +1-973-884-4794  
**Sales Email:** [sales@aicipc.com](mailto:sales@aicipc.com)  
**Support Email:** [support@aicipc.com](mailto:support@aicipc.com)

## Houten, The Netherlands

**Address:** Peppelkade 58, 3992AK, Houten,  
The Netherlands  
**Tel:** +31-30-6386789  
**Fax:** +31-30-6360638  
**Sales Email:** [sales@aicipc.nl](mailto:sales@aicipc.nl)  
**Support Email:** [support@aicipc.com](mailto:support@aicipc.com)

For additional technical support or questions about trouble shooting, please contact the AIC® representative nearest to you or visit our AIC® website for more information.  
AIC® website: <https://www.aicipc.com/en/faq>.