



康舒科技

ACBEL POLYTECH INC.

Approval Sheet

Model No. : FSE052 Option 00CG
MKT Model No. : R1CA2801A Option P00C
Hardware Rev. : A04
Software Rev. : APM12V0100

Customer
Customer PN



Approval by :

Smith Lu

Prepare by : Sonia Chuang

Date: 09/02/2021



康舒科技

ACBEL POLYTECH INC.

Contents

- 1. Specification**
- 2. Mechanical Outline Drawing**
- 3. I/O Label Drawing**
- 4. Carton Drawing**
- 5. Safety**



康舒科技

ACBEL POLYTECH INC.

Specification



ACBEL POLYTECH INC.

R1C Series 800W

Power Module Specification

Model Number: R1CA2801A-P Series

AcBel PN: FSE052-00CG

80Plus Platinum Compliant

Note: Outward Airflow

Revision: A00

Release Date: 2014/11/30

Released by: Johnny Ho

Change Date: 2020/05/04

Changed by: Rwei Zong

REVISION LOG

DATE	SECTION	REVISION	ISSUE / DESCRIPTION
2020/05/04		A00	Reference from FSE052-000G Rev A07
2020/05/04	2.1.6		Modify Holdup time is from 16mS to 12mS.
	2.1.7		The efficiency should be allowed 0.5% tolerance for MP stage.
	2.2.1		AC line voltage shall be reduced from 90VAC/60Hz to 0VAC at constant rate 1 V/secs.
	2.2.2		AC line voltage shall be increased from 0VAC to 90VAC/60Hz at constant rate 1 V/secs
	2.3.4		For dynamic condition +12V min loading is 2A.
	2.3.6		The fan start when standby mode over 2A load, the +12Vsb output ripple noise should be reference to +240 mVp-p.
	3		Delay from PSON# de-asserted to power supply turning off(Minimum Load):TBD ms Delay from PSON# de-asserted to power supply turning off(Maximum Load):15 ms
	4.1		Logic level high (power supply OFF)from 2.7V to 2.0V.
	4.2		Power down delay: T_{pwok_off} form Max 200ms to N/A.
	4.3		Logic level high voltage, Isink=50 μ A form Min 2.4V to 0V.
	5.3		Over Voltage Limits Max(V)form 14.5V to 15V.

1. GENERAL SCOPE

This specification describes the performance characteristic of an **800W** hot swappable AC-DC switching power supply module with a +12V main DC output and a +12Vsb auxiliary output. The power supply shall be able to operate as a single supply or in an N+1 parallel hot-plug able operation with active load sharing in an N+1 redundant configuration.

2. ELETRICAL PERFORMANCE

This Chapter describes the electrical requirements and performance compliances of **R1CA2801A-P** power supply.

2.1 POWER INPUT SPECIFICATION

2.1.1 AC Input Voltage

The power supply must operate within all specified limits over the following input voltage range. Harmonic distortion of up to 10% THD must not cause the power supply to go out of specified limits.

PARAMETER	MIN	RATED	MAX	Brown Out	Brown In
Voltage (115)	90V _{rms}	100-127V _{rms}	140V _{rms}	75Vac+/-4V	85Vac+/-4V
Voltage (230)	180V _{rms}	200-240V _{rms}	264V _{rms}		
Frequency	47Hz		63Hz		

2.1.1.1 HVDC Input Voltage

The power supply supports High Voltage Direct Current (HVDC) input over the C14 Inlet. Allowed HVDC input range as shown in below table. The power supply shall operate within all specified limits, when HVDC input meet requirements defined in this chapter.

PARAMETER	MIN	RATED	MAX	Brown Out	Brown In
HVDC (240)	180V _{DC}	200-240V _{DC}	300V _{DC}	170V _{DC}	170V _{DC} ≤ V _{DC} < 180 V _{DC}

2.1.2 Inrush Current

The power supply must meet inrush requirements for any rated AC voltage; during turn on at any phase of AC voltage, during a single cycle AC dropout condition, during repetitive ON/OFF cycling of AC, and over the specified temperature range (T_{op}). The peak inrush current shall be less than the ratings of its critical components (including input fuse, bulk rectifiers, and surge limiting device), but shall not exceed 35A in general.

2.1.3 Input Current

The maximum input current defines the maximum possible input current to ensure the proper function of the power supply to meet all defined specifications.

Input	Max Current
100Vac – 127Vac	10A
200Vac – 240Vac	5A
240Vdc	5A

2.1.4 Input Power Factor Correction

The input Power Factor shall be greater than values defined in below table at power supply’s rated output, and meet Energy Star® requirements.

Output power	10% load	20% load	50% load	100% load
Power factor	>0.90	>0.95	>0.95	>0.98

Tested at 230VAC, 50Hz and 115VAC, 60Hz.

2.1.5 Harmonic

The harmonic input current defined in below table with various loading conditions which tested at 25 deg. C ambient condition. The input voltages are 115VAC/50Hz and 230VAC/60Hz.

Load Condition	10%	20%	50%	100%
115VAC	10%	10%	5%	5%
230VAC	15%	10%	10%	5%

2.1.6 AC line dropout

An Input line dropout is a transient condition defined as the line input to the power supply drops to 0 VAC at any phase of the AC line or DC line, for any length of time. During an Input dropout the power supply must meet dynamic voltage regulations requirements. An Input line dropout of any duration shall not cause dripping of the control signals and protection circuits. If the Input dropout lasts longer than the holdup time, the power supply should recover when VIN meets $V_{IN\ recover}$ and meet all turn on requirements. An Input dropout of any length shall not cause any damage to the power supply.

Holdup time until Power output goes out of regulations

Loading	Main output	Standby output
100%	12mS	25mS

2.1.7 Efficiency

The efficiency should be measured at 230VAC for AC input power modules only according to Climate Saver / 80Plus efficiency measurement specifications (CSCI-09-10). FAN power loss shall be excluded and need to be deducted from power input.

Efficiency Std.	10% load	20% load	50% load	100% load
Platinum	82%	90%	94%	91%

Note : The efficiency should be allowed 0.5% tolerance for MP stage.

2.1.8 AC Line Transient Specification

AC line transient conditions shall be defined as “sag” and “surge” conditions.

“Sag” conditions are also commonly referred to as “brownout”, these conditions will be defined as the AC line voltage dropping below nominal voltage conditions.

“Surge” will be defined to refer to conditions when the AC line voltage rises above nominal voltage.

The power supply shall meet the requirements under the following AC line sag and surge conditions.

AC Line SAG and SURGE transient performance.

AC Line Sag and Surge (10sec interval between each sagging and surging)

Duration	Sag	Operating AC voltage	Line frequency	Performance criteria
0 to 1/2 AC cycle	95%	Nominal AC Voltage ranges	50/60Hz	No loss of function or performance
>1 AC cycle	>30%	Nominal AC Voltage ranges	50/60Hz	Loss of function acceptable, self-recoverable
Continues	10%	Nominal AC Voltages	50/60Hz	No loss of function or performance
0 to 1/2 AC cycle	30%	Mid-point of nominal AC Voltages	50/60Hz	No loss of function or performance

2.1.9 Power Recovery

The power supply shall recover automatically (auto recover) after an Input power failure. Input power failure is defined to be any loss of Input power that exceeds the dropout criteria.

2.1.10 Input Line Leakage Current

The maximum leakage current to ground for power supply system shall not exceed 3.5mA when tested at 230VAC Input voltages.

2.1.11 Surge Immunity

The power supply shall be tested with the system for immunity to AC Unidirectional wave; 2kV line to ground and 1kV line to line, per EN 55024: 1998/A1: 2001/A2: 2003, EN 6100-4-5: Edition 1.1: 2001-04.

The pass criteria include: No unsafe operation is allowed under any condition all power supply output voltage levels to stay within proper spec levels; No change in operating state or loss of data during and after the test profile No component damage under any condition.

2.2 BROWNOUT

Power supply shall contain protection circuitry such that the application of an input voltage below the minimum specified in section 2.1.3 shall not cause damage to the power supply unit nor cause failure of the input fuse and overstress to any other component. In the event of shutdown due to extended brownout, the power supply shall automatically restart after the AC input is within specified limits. The voltage level between shutdown and recovery shall have a minimum of 5 VAC of voltage hysteresis, so that the power supply will not oscillate on and off due to voltage change condition. The power supply shall meet dynamic voltage regulations (Section 2.3.3) and all turn on requirements or turn off requirements while shutdown or recovery.

2.2.1 AC Turn off Requirements

Power supply shall go to power off state after a slow brownout condition. The brownout condition shall be tested with all valid redundant power system configurations using the system. While the power system is operating at full rated DC load, the AC line voltage shall be reduced from 90VAC/60Hz to 0VAC at constant rate 1 V/sec. Power supply shall shutdown at the AC voltage 75VAC±4VAC.

2.2.2 AC Turn on Requirements

Power supply shall return to normal power up state after a slow recovery condition. The recovery shall be test ed in all valid redundant power system configurations. With the test loads configured for maximum system DC output in resistive mode, the AC line voltage shall be increased from 0VAC to 90VAC/60Hz at constant rate 1 V/sec. Power suppl y shall turn up at th e AC voltage 85VAC±4VAC.

2.3 POWER OUTPUT SPECIFICATION

2.3.1 Output Power/Currents

The following table defines the power and current rating of the **800W** power supply.

Voltage	VAC	Mini	Max	Peak
+12V main	100-240	0.5A	66.7A	86.7A
+12Vsb		0.1A	3A	3.9A

1. Maximum continuous total DC output power should not exceed 800W.
2. Maximum peak total DC output power should not exceed 1120W.

2.3.2 Peak Power Condition

The power supply shall meet the following peak power conditions.

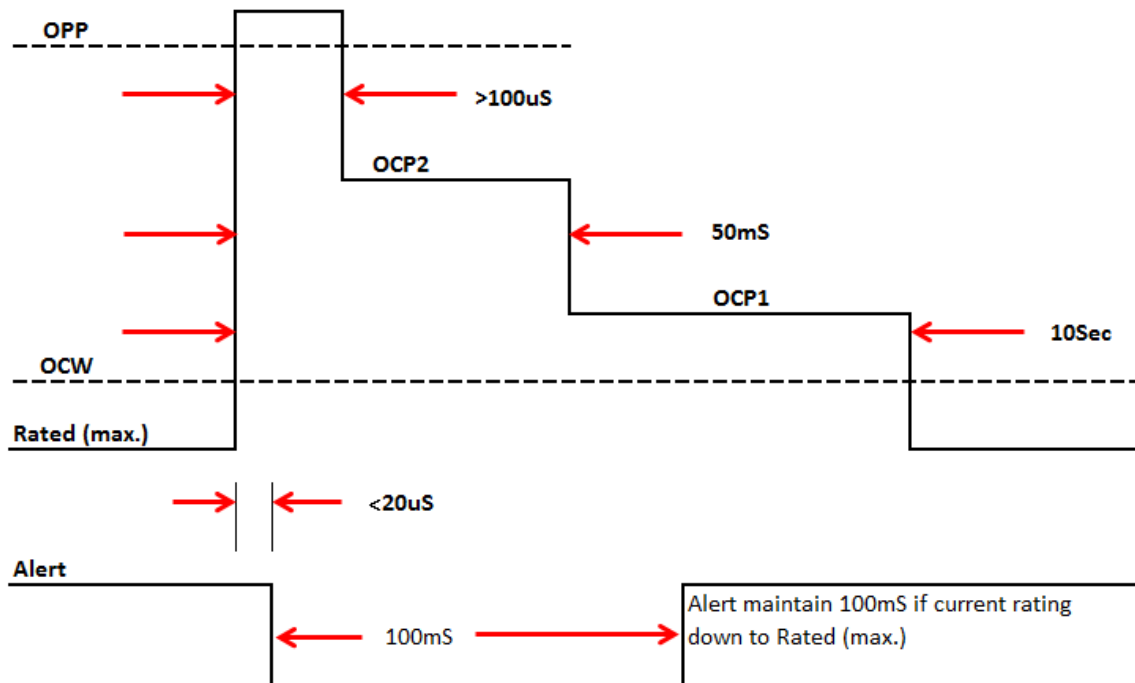

Parameter	MIN	NOM	MAX	Condition
OPP	140%	145%	150%	Keep 100uS at least
OCP2	125%	133%	140%	Keep 50mS at least
OCP1	115%	120%	125%	Keep 10Sec at least
OCW	105%	110%	115%	Continue
Rated	0%		100%	Continue

1. Peak power condition shall be following the peak power table as specify from the above. After exceeding the max. peak power threshold of T_{OFF_PEAK} , the power supply will shut down in a OPP state, and according warning and failures will be reported.

2. The warning signal (OCW) will send to system during 105% - 115% of maximum load, and shuts down after follow by the specified condition.
3. The OPP shall be kept 100uS at least which included < 20uS of SMBAlert and 80uS at least from 12V main rail.

2.3.3 Voltage Regulation

The power supply shall stay within the following voltage limits when operating at steady state and dynamic loading conditions. These limits include the peak-peak ripple/noise conditions specified in paragraph 2.2.5. All outputs are measured with reference to the return remote sense (ReturnS) signal.

Parameter	MIN	NOM	MAX	Units	Tolerance
+12V	+11.40	+12.00	+12.60	V _{rms}	+/-5%
+12Vsb	+11.40	+12.00	+12.60	V _{rms}	+/-5%

2.3.4 Dynamic Loading

The power supply shall operate within specified limits and meet regulation requirements for step loading and capacitive loading specified below.

The load transient repetition rate shall be tested between 50Hz to 5kHz at duty cycles ranging from 10%-90%. The load transient repetition rate is only a test specification. The Δ step load may occur anywhere within the MIN load and the MAX load.

Output	ΔStep Load Size	Load Slew Rate	Capacitive Load
+12V	60% of max load	0.5 A/μs	1,000 μF
+12Vsb	1.0A	0.5 A/μs	1,000 μF

Note: For dynamic condition +12V min loading is 2A.

2.3.5 Capacitive Loading

The power supply shall meet all requirements with the following capacitive loading ranges.

Output	MIN	MAX	Units
+12V	500	36,000	μF
+12Vsb	20	3,100	μF

2.3.6 Ripple and Noise

Ripple and Noise shall be measured over a Bandwidth of 20MHz at the power supply output connector, with minimum capacitive load as specified within paragraph 2.2.4 in parallel with a 10µF tantalum capacitor (minimum 100mΩ ESR) and with a 0.1µF ceramic capacitor placed at the point of measurement. Maximum allowed ripple/noise output of the power supply is defined in table below.

+12V	+12Vsb
120 mVp-p	120 mVp-p

Note : The fan start when standby mode over 2A load, the +12Vsb output ripple noise should be reference to +240 mVp-p.

The test set-up shall be as shown below:

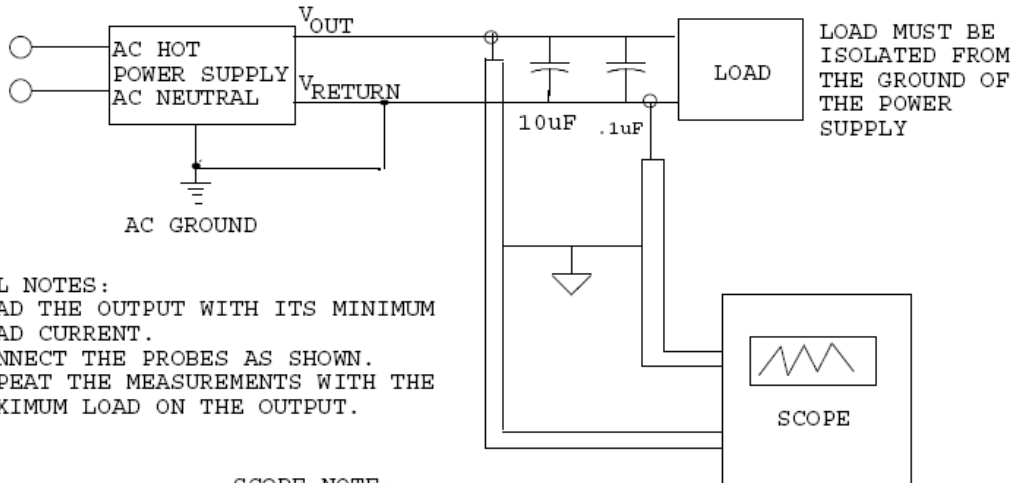

- GENERAL NOTES :
1. LOAD THE OUTPUT WITH ITS MINIMUM LOAD CURRENT.
 2. CONNECT THE PROBES AS SHOWN.
 3. REPEAT THE MEASUREMENTS WITH THE MAXIMUM LOAD ON THE OUTPUT.

SCOPE NOTE:
 USE A TEKTRONIX 7834 OSCILLOSCOPE WITH 7A13 AND DIFFERENTIAL PROBE P6055 OR EQUIVALENT.

3. TIMING REQUIREMENTS

These are the timing requirements for the power supply operation. The output voltages must rise from 10% to within regulation limits (T_{vout_rise}) within 5 to 70ms, and 1 to 25ms for 12Vsb. All main outputs must rise monotonically. Table below shows the timing requirements for the power supply begin turned on and off via the AC input, with PSON held low and the PSON signal, with the AC input applied.

Item	Description	MIN	MAX	Units
T_{vout_rise}	Output voltage rise time for 12V main output	5	70	ms
	Output voltage rise time for 12Vsb output	1	25	ms

Turn On/Off Timing

Item	Description	MIN	MAX	UNITS
$T_{sb_on_delay}$	Delay from ac begin applied to 12Vsb begin within regulation.		1500	ms
$T_{ac_on_delay}$	Delay from AC begin applied to all output voltage begin within regulation.		3000	ms
T_{out_holdup}	Time all output voltages stay within regulation after loss of AC.	17		ms
T_{pwok_holdup}	Delay from loss of AC to de-assertion of PWOK.	16		ms
$T_{pson_off_delay}$	Delay from PSON# de-asserted to power supply turning off(Minimum Load)		TBD	ms
$T_{pson_off_delay}$	Delay from PSON# de-asserted to power supply turning off(Maximum Load)		15	ms
$T_{pson_on_delay}$	Delay from PSON# active to output voltages within regulation limits.	5	400	ms
T_{pson_pwok}	Delay from PSON# de-active to PWOK begins de-asserted.		5	ms
T_{pwok_on}	Delay from output voltages within regulation limits to PWOK asserted at turn on.	100	500	ms
T_{pwok_off}	Delay from PWOK de-asserted to 12V output voltage dropping out of regulation limits.	1		ms
T_{psok_low}	Duration of PWOK begin in the de-asserted state during an off/on cycle using AC or the PSON# signal.	100		ms
T_{sb_vout}	Delay from 12Vsb begin in regulation to O/Ps begin in regulation at AC turn on.	50	1000	ms
T_{12VSB_holdup}	Time the 12VSB output voltage stays within regulation after loss of AC.	70		ms

Turn On/Off Timing (single Power supply)

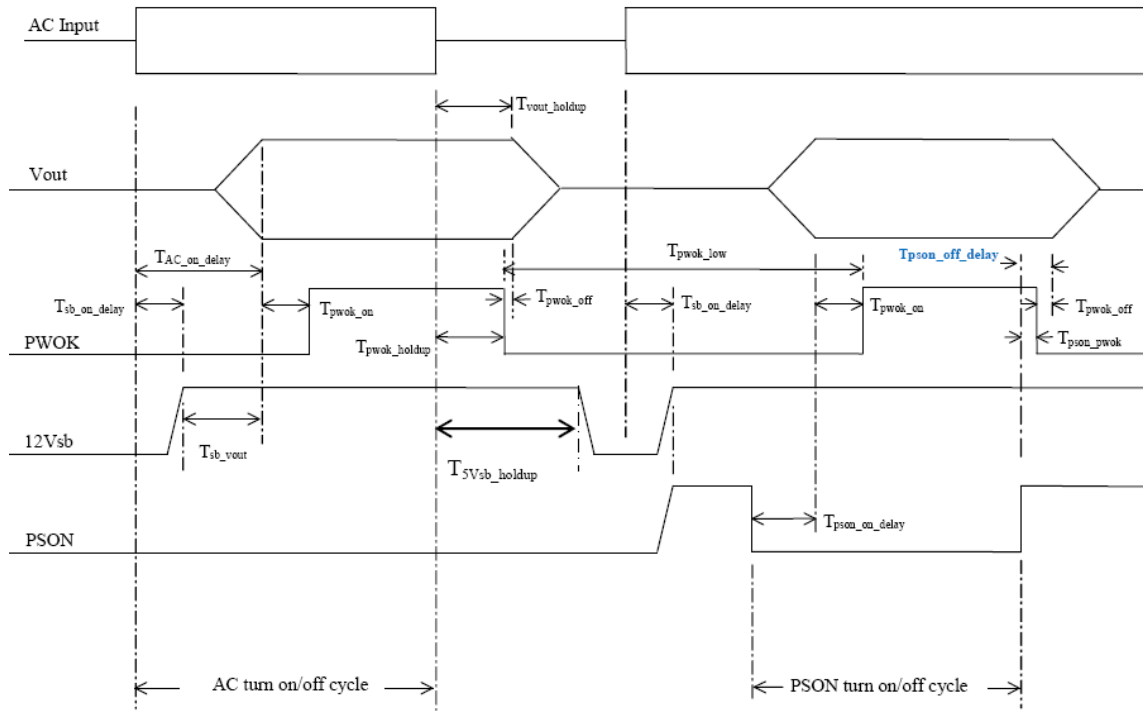

4. CONTROL AND INDICATOR FUNCTIONS

The following section defines the input and output signals from the power supply.

Signals that can be defined as low true use the following convention:

Signal[#] = low true.

4.1 PSON[#] INPUT SIGNAL (POWER SUPPLY ENABLE)

The PSON[#] signal is required to remotely turn on/off the main output of the power supply. PSON[#] is an active low signal that turns on the main output power rail. When this signal is not pulled low by the system or left open, the outputs (except the Standby output) turn off. PSON[#] is pulled to a standby voltage by a pull-up resistor internal to the power supply.

PSON[#] Signal Characteristic

Signal Type	Accepts a drain input from the system. Pull-up to 3.3V located in power supply	
PSON [#] = Low	ON	
PSON [#] = High or Open	OFF	
	MIN	MAX
Logic level low (power supply ON)	0V	0.6V
Logic level high (power supply OFF)	2.0V	3.46V
Source current, $V_{pson} = \text{low}$		4mA
Power off delay: $T_{pson_off_delay}$		5msec
Power up delay: $T_{pson_on_delay}$	5ms	400msec
PWOK delay: T_{pson_pwok}		50msec

4.2 POWER OK (PWOK OR PG) BUS

PWOK is a power good signal and shall be pulled HIGH by the power supply to indicate that all outputs are within regulation limits. When any output voltage falls below regulation limits, an internal failure or when AC power has been removed for a time sufficiently long, so that power supply operation is no longer guaranteed, PWOK will be de-asserted to a LOW state. The start of the PWOK delay time shall inhibited as long as any power supply output is in current limit.

PWOK / PG Signal Characteristics

Signal Type	A drain output from power supply. Pull-up to 3.3V located in the power supply.	
PWOK = High	Power OK	
PWOK = Low	Power Not OK	
	MIN	MAX
Logic level low voltage, $I_{sink} = 4\mu\text{A}$	0V	0.4V
Logic level high voltage, $I_{source} = 200\mu\text{A}$	2.4V	3.46V
Sink current, PWOK = low		400 μA
Source current, PWOK = high		2mA
PWOK delay: T_{pwok_on}	100ms	500ms
PWOK rise and fall time		100 μsec
Power down delay: T_{pwok_off}	1ms	

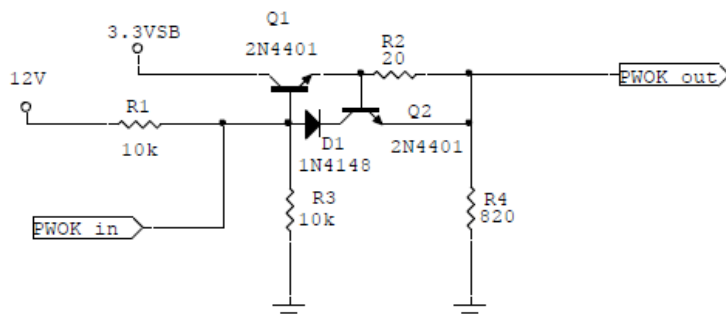

4.3 SMBAlert# Signal

This signal indicates that the power supply is experiencing a problem that the user should investigate. This shall be asserted due to Critical events or Warning events and activate in the case of SMBAlert_mask setting by user(note). This signal may also indicate the power supply is reaching its end of life or is operating in an environment exceeding the specified limits. This signal is to be asserted in parallel with LED turning solid Amber or blink Amber.

Note: There are input UVP 、 output OCW 、 OTW assert SMBAlert# follow Intel SPEC.

SMBAlert# Signal Characteristics

Signal Type (Active Low)	A drain output from power supply. Pull-up to 3.3V located in power supply.	
Alert# = High	OK	
Alert# = Low	Power Alert to system	
	MIN	MAX
Logic level low voltage, Isink=4 mA	0 V	0.4 V
Logic level high voltage, Isink=50 μA		3.46 V
Sink current, Alert# = low		4 mA
Sink current, Alert# = high		50 μA

4.4 Cold Redundant_Bus (CR_BUS) Signal

This signal is used for power supply to power supply communication in front of an interrupt. This interrupt is by default low impedance low. For all power supplies connected to this bus shall have an open collector and a pull high circuitry, which can provide at least 4mA.

This function shall be PMBus controlled and allows the system, to set the power module into four different modes:

1. MASTER – Load dependent function
2. SLAVE – Load dependent function
3. MASTER – HVDC Input dependent function
4. SLAVE – Master dependent function

SLAVE’s in CR Standby shall provide PG and LED should be 1Hz Blink GREEN.

CR_BUS# Signal Characteristics

Signal Type (Active HIGH)	A drain output from power supply. Pull-up to 3.3V located in power supply.	
CR_BUS# = High	CR Standby Allowed	
CR_BUS# = Low	SLAVEs need to be Active ON	
	MIN	MAX
Logic level low voltage, Isink=4 mA	0 V	0.4 V
Logic level high voltage, Isource=4 mA	2.4V	3.46 V
Sink current, CR_BUS# = low		4 mA
Sink current, CR_BUS# = high		4 mA
CR_BUS# rise and fall time		100 μs

5. PROTECTION CIRCUITS

Protection circuits shall cause only the power supply's main outputs to shutdown (latch off). If the power supply latches off due to a protection circuit tripping, an AC cycle OFF for 15 second or a PSON# cycle HIGH for 1 second must be able to reset the power supply. The auxiliary output shall not be affected by any protection circuit, unless the auxiliary output itself is affected.

5.1 CURRENT LIMIT

The power supply shall prevent the main and auxiliary outputs from exceeding the values shown in below Table. If the main current limits are exceeded the power supply will shut down and latch off. The latch will be cleared by toggling the PSON# signal or by an AC power interruption. The power supply shall not be damage from repeated power cycling in this condition. *The auxiliary output shall be auto recover ($V_{sb_{AR}}$) after the OCP/SCP had been removed.*

Over Current Protection

Voltage	Over Current Limit (Iout limit)
+12V	110% minimum, 150% maximum
+12Vsb (<i>Auxiliary</i>)AR	110% minimum, 150% maximum

5.2 FAST OUTPUT CURRENT SENSING

The power supply shall have a circuit to quickly assert the SMBAlert signal when the output current exceeds the $I_{throttle}$ threshold. A current sense resistor on the output side of the PSUs output capacitors shall be used to quickly sense current exceeding the $I_{throttle}$ threshold. The SMBAlert# signal shall assert within $T_{fast_smbalert}$ time. The PSU shall hold the SMBAlert# signal asserted for $T_{smbalert_latch}$ duration then release it.

Key characteristics of the fast output current sensing requirements

- Ithrottle < minimum OPP level (SMBAlert must assert before current/power hits the OPP threshold)
- Tfast_smbalert < 20uSec
- Tsmbalert_latch = 100mSec (+/-50mSec)

5.3 OVER VOLTAGE PROTECTION

The power supply shall shutdown and latch off after an over voltage condition occurs. This latch will be cleared by toggling the PSON# signal or by an AC power interruption.

A shutdown caused by an over-voltage in one power supply will not cause the other (redundant) power supply to shuts down.

The over-voltage threshold is defined in table below.

Over Voltage Limits		
Output Voltage	MIN (V)	MAX (V)
+12V	13.8	15
+12Vsb (<i>Auxiliary</i>)AR	13.3	15

5.4 OVER TEMPERATURE PROTECTION

The power supply shall be protected against over temperature conditions caused by loss of fan cooling or excessive ambient temperature which could cause internal part failures. In an over temperature condition the power supply shall shutdown, then recover after while the temperature back in normal condition. The 12VSB shall not shutdown during an OTP condition on the main outputs.

The temperature warning setting point is showing on below table:

Condition	Warning in °C	Critical in °C	Timing for LED	Timing for SMBAlert[#]
T _{READ}	55	60	1sec	100usec

T_{READ}: Environment Temperature

6. LED IDENTIFICATION

There is one indicator LED located on the front faceplate.
 Status showing on below:

Power Supply Condition	LED State
Output ON and OK	GREEN
Only 12Vsb on (PS off) or PSU in Cold redundant state	1Hz Blink GREEN
Power supply warning events where the power supply continues to operate high temp, high power, high current, slow FAN.	1Hz Blink AMBER
Power supply critical event causing a shutdown; AC cord unplugged or AC power lost, failure, OCP, OVP, FAN fail.	AMBER

7. POWER SUPPLY MANAGEMENT

7.1 HARD WARE LAYER

The serial bus communication devices for Power Supply Management Controller (PSMC) and Field Replacement Unit (FRU) in the power supply shall be compatible with both SMBus 2.0 “high power” and I²C Vdd based power and drive specification.

This bus shall operate at 3.3V. The power supply should have internal pull-ups on the SMBus. Two pins are allocated on the power supply. One pin is the serial clock (SCL). The second pin is used for serial data (SDA). Both pins are bi-directional and are used to form a serial bus. The device(s) in the power supply shall be located at an address(s) determined by addressing pins A0 and A1 on the power supply module. The circuits inside the power supply shall derive their 3.3V power from the 12VSB bus through a buffer. Pull-up resistors shall be on SCL or SDA inside the power supply. Pull-up resistor is 10K ohm for SDA and SCL separately.

7.1.1 Capacitance for SMBus

The recommended Capacitance per pin on SDA and SCL shall be 10pF, and is not allowed to exceed 40pF per pin. In an N+1 configuration of up to four (4) power modules with additional PDB, the total Capacitance of each Bus pin shall not exceed 400pF.

7.1.2 I²C Bus Noise Requirement

The power supplies I²C Bus’ SDA and SCL line shall be clean from noise, which might affect the proper function when utilized with other devices.

The maximum allowed line noise on SDA or SCL is 200mV.

7.2 POWER SUPPLY MANAGEMENT CONTROLLER (PSMC)

The PSMC device on the PDB shall derive its power of the 12Vsb output on the system side of the O’ring device and shall be grounded to return. It shall be compatible with SMBus specification 2.0 and PMBus™ Power System Management Protocol Specification Part I and Part II in Revision 1.2 or later

It shall be located at the address set by the A0 and A1 pins.
 Refer to the specification posted on www.ssiforum.org and www.pmbus.org website for details on the power supply monitoring interface requirements and refer to followed section of supported features. The below table reflect the power module addresses complying with the position in the housing.

PDB position and PSMC address	PM1 B0h/B1h	PM2 B2h/B3h	PM3 B4h/B5h	PM4 B6h/B7h
Pin A0/A1	0/0	1/0	0/1	1/1

Note: Pull-up resistor is 14.3K ohm for A0 and A1 separately.

7.3 Sensor Accuracy

The sensor of the PSMC shall meet below accuracy requirements for sensor readings. The accuracy shall be met at the specified environmental condition and the full range of rated input voltage.

Sensor Accuracy Table

Sensor	0%-10% load	>10%-20% load	>20%-100% load
Current	± 5% or 0.5A	± 5% or 0.5A	± 3%
Voltage	± 5%	± 3%	± 3%
Output Power	± 10W	± 5% or 10W	± 3%
Temperature	± 3°C with Δ5%		
FAN	± 10% from Spec.		
Input Power	± 10W	± 5%	± 3%

**** PMBus compliance please refer to firmware specification ****

8. ENVIRONMENTAL

8.1 TEMPERATURE REQUIREMENTS

The power supply shall operate within all specified limits over the Top temperature range. The average air temperature difference (ΔT_{ps}) from the inlet to the outlet of the power supply shall not exceed the values shown below Table. All airflow shall pass through the power supply and not over the exterior surfaces of the power supply

ITEM	DESCRIPTION	MIN	MAX	UNITS
Top	Operating temperature range.	0	50	°C
Tnon-op	Non-operating temperature range.	-40	70	°C

8.2 HUMIDITY

Operating: 10% to 95% relative humidity, non-condensing.
Storage: 10% to 95% relative humidity, non-condensing.

8.3 ALTITUDE

Operating: to 5,000m
Non-operating: to 15,200m

8.4 VIBRATION

Operating: 0.01G²/Hz at 10Hz, 0.02G²/Hz at 20Hz.
Non-Operating: 0.02G²/Hz form 20Hz to 1000Hz.

8.5 MECHANICAL SHOCK

Operating: 5G, no malfunction.
Non-operating: 50G, no damage. Trapezoidal Wave, Velocity change = 4.3m/sec. Three drops in each of six directions are applied to each of the samples.

8.6 EMI/EMC REQUIREMENTS

The power supply shall comply with FCC part 15, CRISP 22 and EN55-22; Class A for both conducted and radiated emissions with a 3dB margin. Test shall be conducted using a shielded DC output cable to a shielded load. The load shall be adjusted to 100% load. Tests will be performed full load on each output power at 120VAC, 60Hz, and 230VAC, 50Hz.

9. REGULATORY REQUIREMENTS

9.1 PRODUCT SAFETY COMPLIANCE

The power supply will have the following safety approvals with most current editions:

- A) UL 60950-1/CSA 60950-1 Edition 2 (USA/Canada)
- B) TUV EN60950-1 Edition 2 (Europe)
- C) IEC60950-1 Edition 2 (International)
- D) CB Certificate & Report, IEC60950-1 Edition 2
- E) CE – Low Voltage Directive 2006/95/EC (Europe)
- F) BSMI (Taiwan)
- G) GB4943-2011 Certification (China)
- H) KCC (Korea)

9.2 ELECTROSTATIC DISCHARGE

The objective of ESD test is to determine the susceptibility and immunity of products to electrostatic discharge to which the products may be exposed, when operating under all potential environmental conditions. The test conditions and setup shall conform to that outlined in CISPR24-2 and IEC 801-2 (EN55101-2).

Air discharge: 8KV not allow error.

Contact discharge: 4KV not allow error.

Note: The above test discharge time is 1 time/sec and repeats each test 10 times.

9.3 HI-POT

The power supply module in the system shall be test at 1800Vac, with a trigger limit of 30mA.

10. RELIABILITY

The MTBF of the power supply can be calculated with the Part-Stress Analysis method of Bell Core SR332 of the quality factors. A calculated MTBF of the power supply shall be at least 100,000 hours at 50 °C ambient with 230VAC and in full load condition.

11. RoHS COMPLIANCE

The directive 2002/95/EC of the European Parliament and of the Council of the 27th January 2003, on the restriction of the use of certain hazardous substances in electrical and electronic equipment, requires the reduction of the substances Lead, Mercury, Cadmium, Hexavalent Chromium, Polybrominated Biphenyls (PBB), and Polybrominated Biphenyl ethers (PBDE) in electronic products by July 1, 2006. Unless otherwise noted, all materials used will be compliant with this directive and any subsequent revisions or amendments.

12. MECHANICAL DIMENSIONS

Dimension (L x W x H): 185 x 73.5 x 40mm / 7.28 x 2.89 x 1.57inch

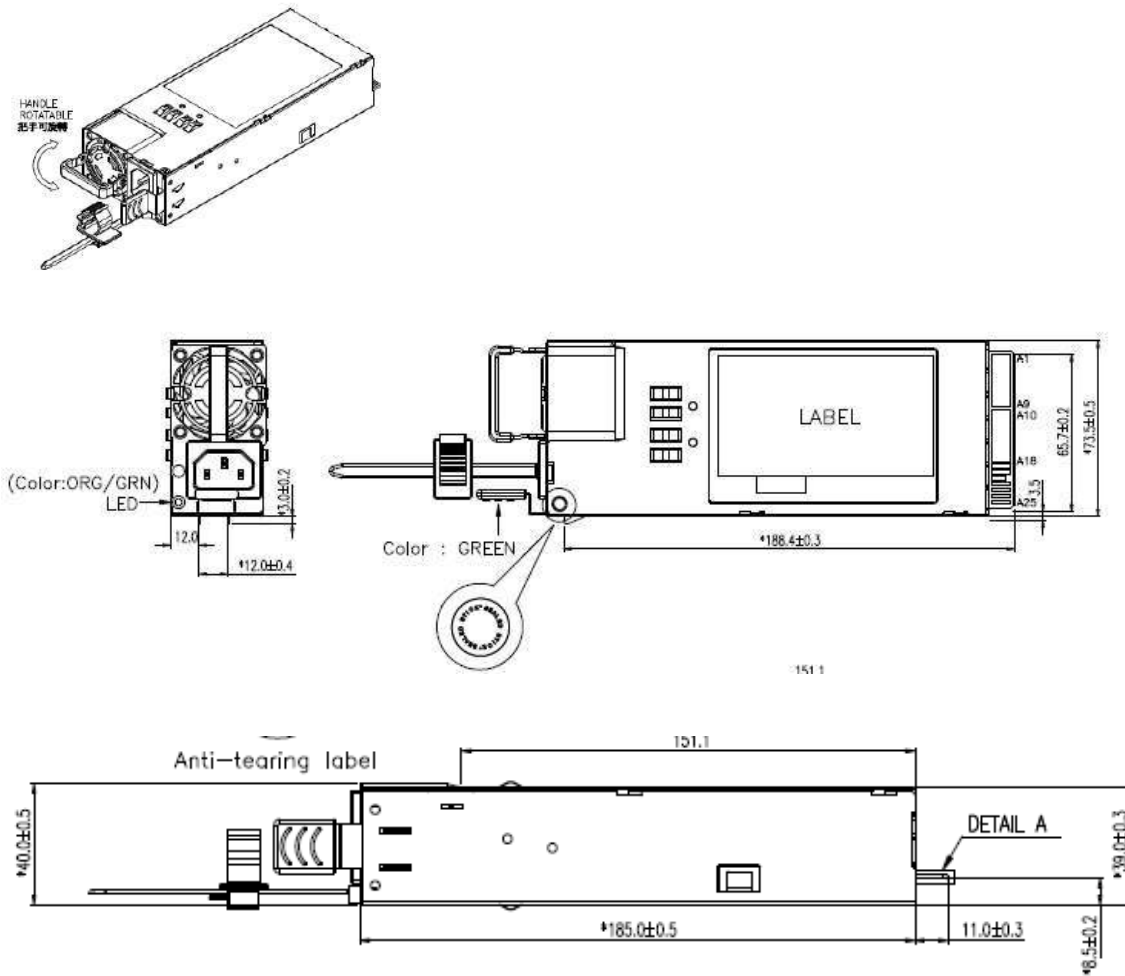

NOTE: Above drawing is for reference only, detail dimension should refer to independent mechanical drawing.

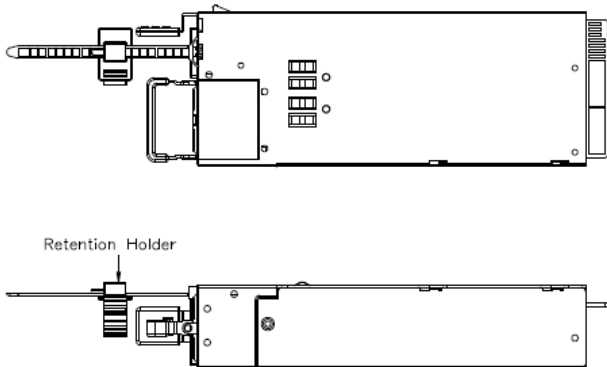

The height of adapter gold finger to the bottom is 8.5mm

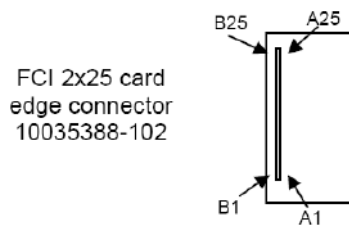
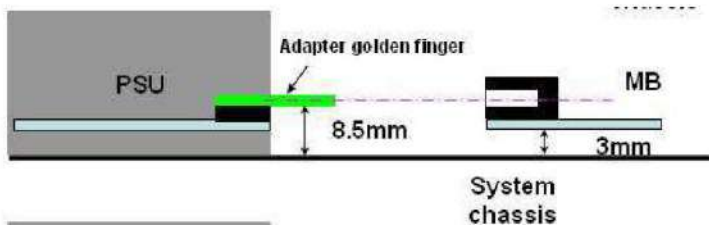

12.1 DC Output connector

The power supply shall use a card edge output connection for power and signal that is compatible with a 2x25 Power Card Edge connector (equivalent to 2x25 pin configuration of the FCI power card connector 10035388-102LF or ALLTOP C21009-102H3-Y).

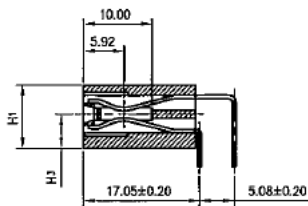
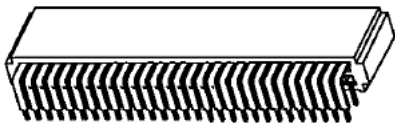
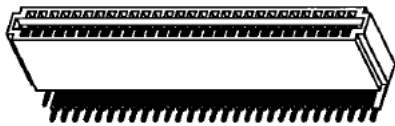

Gold finger pin assignment

OUTPUT PIN ASSIGNMENT

PIN	SIGNAL_NAME	PIN	SIGNAL_NAME
A1	GND	B1	GND
A2	GND	B2	GND
A3	GND	B3	GND
A4	GND	B4	GND
A5	GND	B5	GND
A6	GND	B6	GND
A7	GND	B7	GND
A8	GND	B8	GND
A9	GND	B9	GND
A10	+12V	B10	+12V
A11	+12V	B11	+12V
A12	+12V	B12	+12V
A13	+12V	B13	+12V
A14	+12V	B14	+12V
A15	+12V	B15	+12V
A16	+12V	B16	+12V
A17	+12V	B17	+12V
A18	+12V	B18	+12V
A19	PMBus SDA	B19	A0 (SMBus address)
A20	PMBus SCL	B20	A1 (SMBus address)
A21	PSON	B21	12VSB
A22	SMBAAlert#	B22	CR_BUS#
A23	Return Sense	B23	12V load share Bus
A24	+12V Remote Sense	B24	NC(Reserved)*
A25	PWOK	B25	NC

*Default is internally pulled low after initial.

Description Gold finger

OUTPUT PIN DEFINITION

Pin No.	Pin Name	Pull Up Resistor	Description
A1~A9 B1~B9	GND	N/A	12V main & 12VSB Return
A10~A18 B10~B18	12V	N/A	12V main output
A19	SDA	10K ohm is pulled high to 3.3V(damping 47ohm)	SMBus/PMBus Data
A20	SCL	10K ohm is pulled high to 3.3V(damping 47ohm)	SMBus/PMBus Clock
A21	PSON	14.3K ohm is pulled high to 3.3V	Active low; 12V main output on/off control
A22	SMBAlert	5.1K ohm is pulled high to 3.3V, 0 ohm is pull low to GND.	Active High; Alert Signal (interrupt)
A23	RETURN_S	N/A	12V main output Remote Sense (-)
A24	+12VRS	N/A	12V main output Remote Sense (+)
A25	PWOK	20 ohm is pulled high to 3.3V, 820 ohm is pulled low to GND	Active high; Indicate 12V main is valid.
B19	A0	14.3K ohm is pulled high to 3.3V	PMBus Address 0
B20	A1	14.3K ohm is pulled high to 3.3V	PMBus Address 1
B21	12VSB	N/A	Standby Voltage
B22	CR_Bus#	Connect to other PSU b22	Cold Redundant BUS
B23	12VLS	Connect to other PSU b23.	12V main output load current sharing
B24	N/A	N/A	Power Supply Reserved
B25	NC	N/A	Not connect



康舒科技

ACBEL POLYTECH INC.

Mechanical Outline Drawing

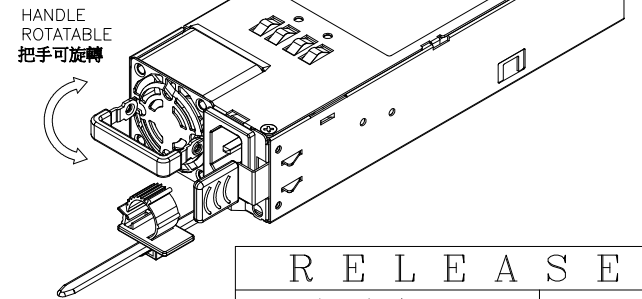
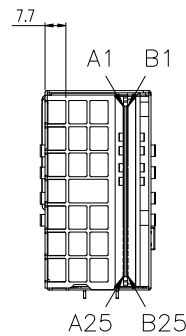
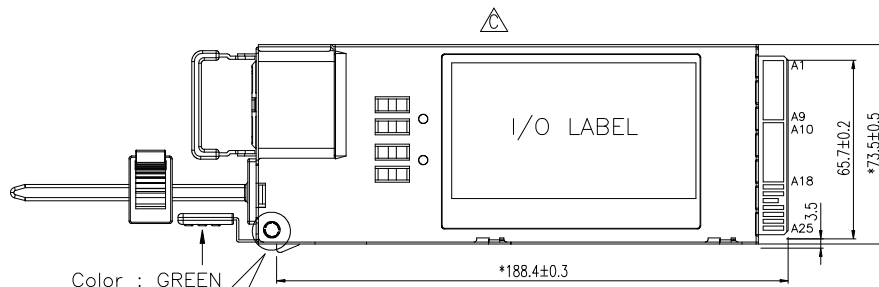
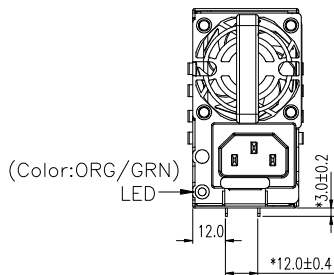
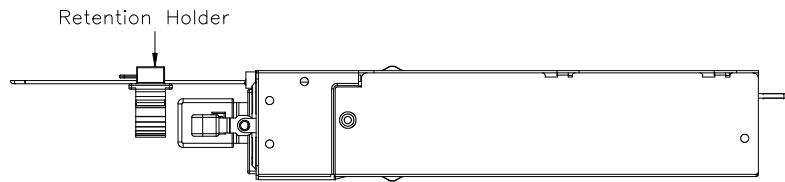
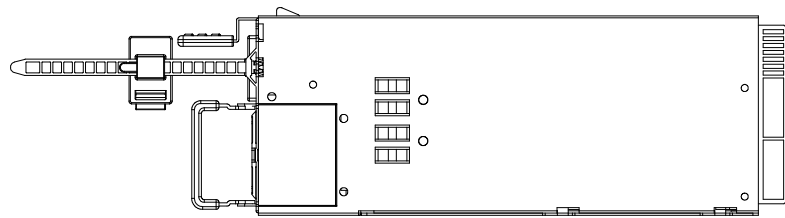

RELEASE	
正式發行圖面	REV: C
ENG. <i>Ting</i>	APPR.

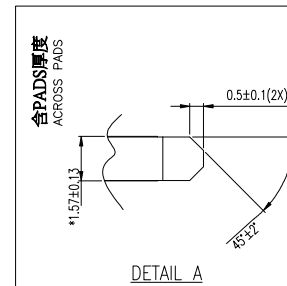
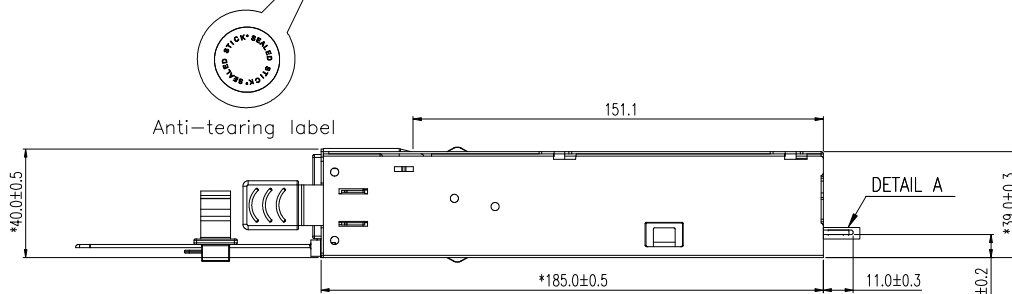

- NOTE :
- UNIT : MM. 單位 : 毫米
 - MATERIAL : SGCC. 材質 : SGCC

THICKNES : COVER 0.8 mm , CHASSIS 0.8 mm
 厚度 : 上蓋 0.8 mm , 下蓋 0.8 mm

- NET WEIGHT : 800g±3% 淨重 : 800克 3%
- " * " CRITICAL DIMENSION. THE SUPPLIER COMPLY TO ACBEL SPEC DIMENSION FOR EVERY SHIPMENT.
 " * " 表示該(尺寸/位置)為設計之重點尺寸, 供應商每次出貨前必須檢驗合格後, 方可出貨.
- THESE MATERIAL/PART/ASSEMBLY MUST COMPLY TO ACBEL SPEC "CRITERIA FOR ENVIRONMENT-RELATED SUBSTANCES".
 材質/零件/製程均必須符合康舒"環境管理物質規範".

REV	DESCRIPTION	BY	DATE
△	刪除上蓋多餘線條	TING	12/17/18
B	COVER & CHASSIS UPDATE	JACKY	04/21/16
A	RELEASE	JACKY	11/19/15
4	增加Retention Holder	JACKY	07/20/15
3	上蓋開孔更正	JACKY	07/15/16
2	INCREASE Anti-tearing label	JACKY	07/13/15
1	PRIMARLY	JACKY	07/08/15

 ACBEL POLYTECH INC.	MODEL NO. FSE052-000G
	PART NO. MO-FSE052-000G
	DWG NO. MO-FSE052-000G_C
TITLE	
MECHANICAL OUTLINE	
DESIGNER	TING 12/17/18
CHECKED	
APPROVED	

SCALE 1:1 SHEET 1 OF 1



康舒科技

ACBEL POLYTECH INC.

I/O Label Drawing

7 6 5 4 3 2 1

厂内自印(详细见条码及文字内容说明
参考NOTE 16/17 虚线不列印)



MODEL 型号(型号): R1CA2801A
SWITCHING POWER SUPPLY
开关电源(交换式电源供应器)

OPTION :
FRU :
AC INPUT : 交流输入(交流输入)
100-127V~, 50/60Hz ; 10.0A
200-240V~, 50/60Hz ; 5.0A
OR 或(或) DC INPUT : 直流输入(直流输入)
240V --- 5A MAX
DC OUTPUT : 直流输出(直流输出)
+ 12.0V --- 66.7A
+ 12Vsb --- 3.0A
TOTAL POWER 800W MAX.
最大总功率800W(最大总功率800W)
MADE IN CHINA 中国制造(中国製造)
Acbel Polytech (UK) Limited
For UK only : 9 Royal Crescent Glasgow G3 7SP

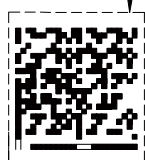

XU100121-16156
정주기술 전원공급장치
제조원 : Acbel Electronic (Dong Gum) Co., Ltd
A/S 연락처 : 070-7094-0600



IS 13252 (Part 1)
IEC60950-1



R-41013579
www.bis.gov.in

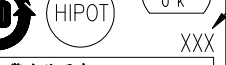

警告使用者:
此为甲類資訊技術設備,於居住環境中使用時,可能會造成射頻擾動,在此種情況下,使用者會被要求採取某些適當的對策。

警告:
此为A级产品,在生活环境中,该产品可能会造成无线电干扰。在这种情况下,可能需要用户对干扰采取切实可行的措施。

此虚线处请由厂商套印厂别码,请参考NOTE19

虚线不列印

厂内自印 NOTE 11
(同SN字印原则)

厂内自印(详细见条码及文字内容说明
参考NOTE 16/17 虚线不列印)

厂内自印(详细见条码及文字内容说明
参考NOTE 16/17 虚线不列印)

厂内自印(详细见条码及文字内容说明
参考NOTE 16/17 虚线不列印)

厂内自印(详细见条码及文字内容说明
参考NOTE 16/17 虚线不列印)

厂内自印(详细见条码及文字内容说明
参考NOTE 16/17 虚线不列印)

厂内自印(详细见条码及文字内容说明
参考NOTE 16/17 虚线不列印)

厂内自印(详细见条码及文字内容说明
参考NOTE 16/17 虚线不列印)

厂内自印(详细见条码及文字内容说明
参考NOTE 16/17 虚线不列印)

厂内自印(详细见条码及文字内容说明
参考NOTE 16/17 虚线不列印)



S-----N

厂内自印 NOTE 11
(同SN字印原则)

厂内自印(详细见条码及文字内容说明
参考NOTE 16/17 虚线不列印)

厂内自印(详细见条码及文字内容说明
参考NOTE 16/17 虚线不列印)

厂内自印(详细见条码及文字内容说明
参考NOTE 16/17 虚线不列印)

厂内自印(详细见条码及文字内容说明
参考NOTE 16/17 虚线不列印)

厂内自印(详细见条码及文字内容说明
参考NOTE 16/17 虚线不列印)

厂内自印(详细见条码及文字内容说明
参考NOTE 16/17 虚线不列印)

厂内自印(详细见条码及文字内容说明
参考NOTE 16/17 虚线不列印)

厂内自印(详细见条码及文字内容说明
参考NOTE 16/17 虚线不列印)

厂内自印(详细见条码及文字内容说明
参考NOTE 16/17 虚线不列印)

厂内自印(详细见条码及文字内容说明
参考NOTE 16/17 虚线不列印)



DEFINITION OF 80PLUS LOGO
THE RADIUS IS 2.5MM
COLOR : PANTONE PMS : COOL GRAY 2C

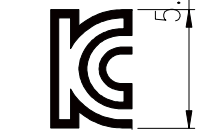
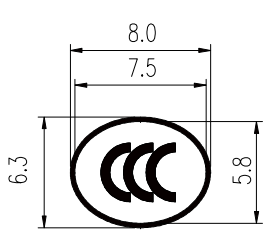

KC LOGO DETAIL DIM.

IS 13252 (Part 1)
IEC60950-1



R-xxxxxxx
www.bis.gov.in

字体: Arial
字号: 6pt



UK CA

RELEASE	
正式發行圖面	REV: J
ENG. Ting	APPR.

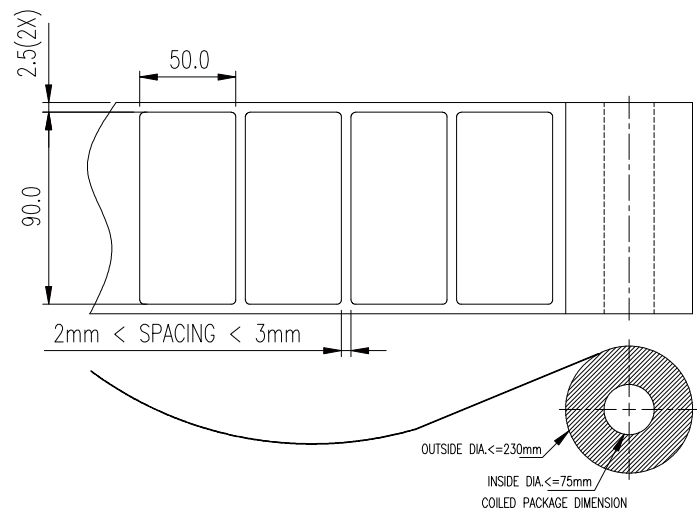

J	UKCA ADDRESS Cresscent -> Crescent	TING	08/13/21
I	ADD UKCA LOGO	TING	03/12/21
H	修改研華二維條碼自印原則	TING	06/09/20
G	增加研華條碼自印原則	TING	09/25/19
F	ADD FCC WARNING STATEMENTS	TING	09/27/18
E	3C LOGO REMOVE S&E	TING	08/15/18
D	CHANGE BSMI LOGO TO BSMI RoHS	JianTing	06/06/17
C	ADD BIS LOGO	JianTing	06/06/17
B	MODIFY KC NUMBER	ALEX	10/19/16
A	RELEASE	JACKY	10/14/15
1	PRIMARY	JACKY	07/03/15
REV	DESCRIPTION	BY	DATE

 ACBEL POLYTECH INC.	MODEL NO. FSE052-00AG
	PART NO. R01AAA-7415II
	DWG. NO :R01AAA-7415II_J
 Metric A3	TITLE I/O LABEL
SCALE NONE SHEET 1 OF 3	DESIGNER TING 08/13/21 CHECKED APPROVED

7 6 5 4 3 2 1

康舒一维条码自印原则: (24码)

1 2 3 4 5 6 7 8 9 10 11 12 13 14 15 16 17 18 19 20 21 22 23 24
 | | | | | | | | | | | | | | | | | | | | | | | |
 □ □ □ □ □ R R R N N N N X Y Y W W S S S S S S

SERIAL NO 000001~999999

DATE CODE (YY: YEAR WW: WEEK)
 FOR EXAMPLE: 2019 30TH WEEK 则此4栏位为"1930"

MFG. FACTORY CODE:
 (东莞康舒印: B; 东莞康展印: T; 武汉康舒印: W)

ID CODE (若机种FSE052-00AG, 则印制"00AG"于此4个栏位)

API REVISION CONTROL CODE (S1印: 0S1; S2印: 0S2; A印: A00; A1印: A01)

API PART NUMBER (若机种FSE052-00AG, 则印制"FSE052"于此6个栏位)

研华一维条码自印原则: (15码)

1 2 3 4 5 6 7 8 9 10 11 12 13 14 15
 | | | | | | | | | | | | | | |
 P P R R R Y Y W W S S S S S S

SERIAL NO 000001~999999

DATE CODE (YY: YEAR WW: WEEK)
 FOR EXAMPLE: 2019 30TH WEEK 则此4栏位为"1930"

API REVISION CONTROL CODE (S1印: 0S1; S2印: 0S2; A印: A00; A1印: A01)

PRODUCTS CODE: 产品自订码 (由业务提供)

R E L E A S E	
正式發行圖面	REV: J
ENG. <i>Ting</i>	APPR.

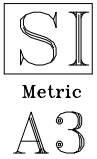
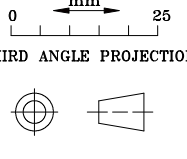
 ACBEL POLYTECH INC.	MODEL NO. FSE052-00AG
	PART NO. R01AAA-7415II
	DWG. NO R01AAA-7415II_J
 	TITLE I/O LABEL
SCALE NONE	DESIGNER TING 08/13/21
SHEET 2 OF 3	CHECKED
	APPROVED

NOTES:

- UNIT : MM.
单位 : 毫米.
- MATERIAL :
2.1 FACE STOCK 底材 :
WHITE POLYESTER, THICKNESS = 0.05 MM.
白雾龙50#, 厚度= 0.05毫米
2.2 OVERLAMINATION 保护膜 :
 A TRANSPARENT FILM 透明胶膜 NONE 无
2.3 ADHESIVE 背胶 : PRESSURE SENSITIVE ACRYLIC 压克力压膜胶
THICKNESS 厚度 = 0.025 MM
2.4 BACKED WITH RELEASE LINER. 背面附离型纸
2.5 LABEL TO BE AFFIXED TO AND MAXIMUM TEMPERATURE RATING 贴纸所贴附之材质与最大耐温等级 :
 GALVANIZED STEEL 镀锌钢 ALUMINUM 铝
 NICKEL PLATED METAL 镀镍金属
 ZINC PLATED METAL WITH CHROMATE POST TREATMENT 后处理之镀铬酸锌金属
 100°C 摄氏100度
2.6 MATERIAL MUST BE UL RECOGNIZED AND COMPLY TO UL 969 STANDARD.
材质必须符合 UL 认证, 并且遵从 UL 969 标准.
- LABEL MUST BE MADE BY A UL RECOGNIZED AND CSA APPROVED VENDOR.
贴纸之制造商必须是 UL 与 CSA 所认证.
- TOLERANCE : XX = +/- 0.5 XX.X = +/- 0.2
XX.XX = +/- 0.15
公差 : XX = +/- 0.5 XX.X = +/- 0.2
XX.XX = +/- 0.15
- "*" CRITICAL DIMENSION SYMBOL, SUPPLIER MUST INSPECT THIS DIMENSION FOR EVERY SHIPMENT
"*" 表示该(尺寸/位置)为设计之重点尺寸, 供应商每次出货前必须检验合格后, 方可出货.
- ALL PRODUCTS MUST BE THE SAME AS ENGINEERING API MECHANICAL ENGINEERING APPROVED SAMPLES, ANY MODIFICATION MUST BE APPROVED BY ACBEL MECHANICAL ENGINEERING SECTION.
所有产品必须与认可的样品一致, 任何的修改都必须经由康舒机构工程师同意及认可.
- LABEL MUST CONTAIN THE VENDOR'S ID MARK LOCATED IN THE AREA INDICATED. ID MARK LETTER HEIGHT TO BE 1.5MM.
贴纸必须印制厂商代码, 代码字高为 1.5 毫米.
- CHARACTER HEIGHT : 1.5 MM , UNLESS OTHERWISE SPECIFIED.
图面未标示之字体高度皆为 1.5 毫米
- PRINTED COLOR :
BLACK - TEXT, GRAPHICS, IMAGE, LOGO SURROUND SHAPE.
WHITE - BACKGROUND.
列印颜色 :
黑色 - 文字、图形、图象、标志、外围图形 白色 - 背景

- THESE MATERIAL/PART/ASSEMBLY MUST COMPLY TO ACBEL SPEC"CRITERIA FOR ENVIRONMENT-RELATED SUBSTANCES".
材质/零件/制程均必须符合康舒"环境管理物质规范".
- BAR CODE FORMAT: CODE 128 / CPI : 13.64
THE NARROW ELEMENT DIMENSION (X DIMENSION) SHOULD BE WITHIN A RANGE OF 0.170MM(0.0067 INCH)
条码格式 : CODE 128 / CPI 13.64 宽/窄比 : 0.17毫米(0.0067英寸)
- BAR CODE & SN & FRU 厂内自印
- REV: XXX (S1印: 0S1; S2印: 0S2; A印: A00; A1印: A01)
- DATE : YYYYWW 为厂内自印, 4码 YYWW 为制造周期, X为工厂代码*
工厂代码 : 康舒东莞厂印B, 康展东莞厂印T, 康舒武汉厂印W
- FRU自印原则
AXXS□□□□□
FW REVISION (印: A0000; A0001; A0002...Z9999)
MINOR REVISION (印: 1; 2; 3...)
MAJOR REVISION (印: 1; 2; 3...)
TYP (PMBUS印: PM; SMBUS印: SM; EEPROM印: EP)
API

16. 二维条码

康舒二维条码自印原则

XXXXXXXXXXXXX;00000ORRNNNNNNXYWWSSSSSS;YYMMDD;XXXXXXXXXXXXX

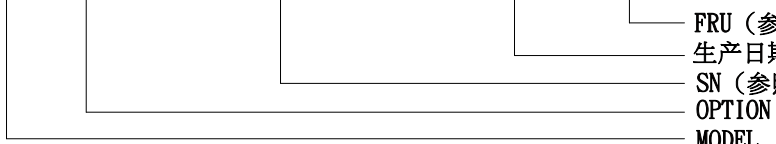

研华二维条码自印原则

XXXXXXXXXXXXX;00000ORRNNNNNNXYWWSSSSSS;YYMMDD;XXXXXXXXXXXXX;P PRRRYWWSSSSSS

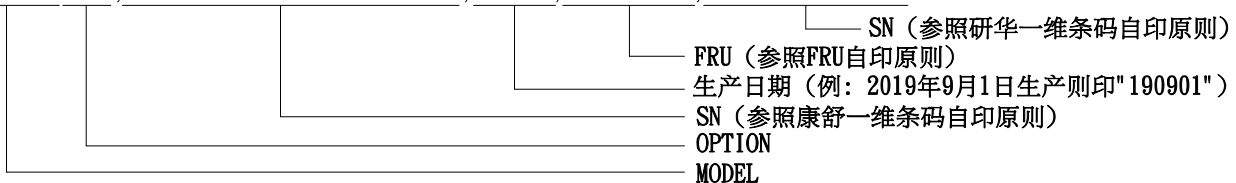

17. 条码及文字内容说明

编码: DATAMATRIX

RELEASE	
正式發行圖面	REV: J
ENG. Ting	APPR.

- 警告符号颜色定义如下 :
PMC BlackC黑色 - 文字 . 图形 . 图象 . 标志
PMC 108C黄色 - 背景

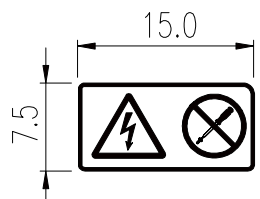

- 加入工厂代码, 如康舒东莞厂生产即印制(B) 如图示, 如康展东莞厂生产即印制(T) 如康舒武汉厂生产即印制(W)

- USES OF RED PHOSPHORUS MATERIAL IS PROHIBITED.
禁止使用含有红磷材料

		MODEL NO. FSE052-00AG
		PART NO. R01AAA-7415II
ACBEL POLYTECH INC.		DWG. NO R01AAA-7415II_J
		TITLE I/O LABEL
		DESIGNER TING 08/13/21
SCALE NONE SHEET 3 OF 3		CHECKED
		APPROVED



康舒科技

ACBEL POLYTECH INC.

Carton Drawing

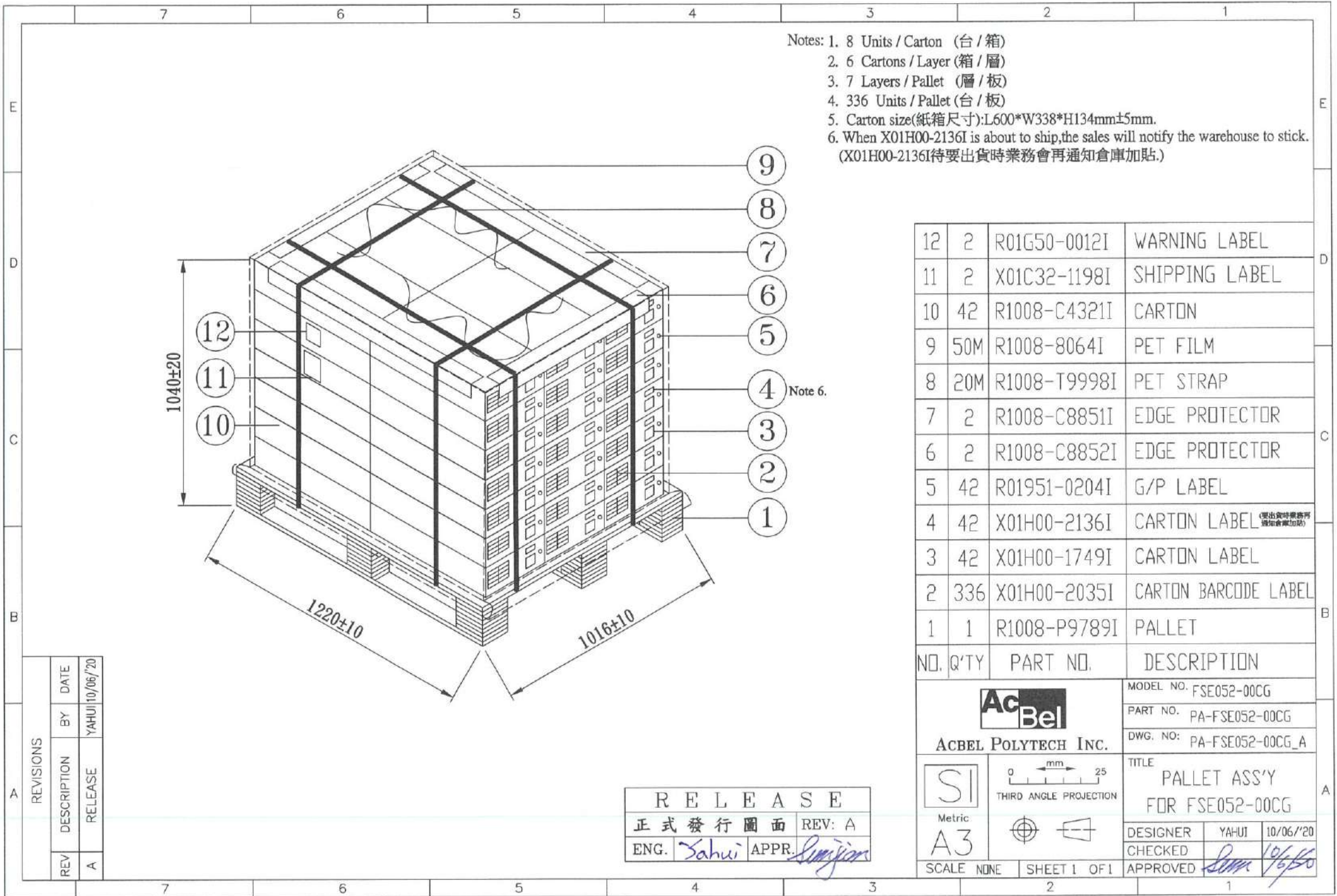

- Notes: 1. 8 Units / Carton (台 / 箱)
 2. 6 Cartons / Layer (箱 / 層)
 3. 7 Layers / Pallet (層 / 板)
 4. 336 Units / Pallet (台 / 板)
 5. Carton size (紙箱尺寸): L600*W338*H134mm±5mm.
 6. When X01H00-2136I is about to ship, the sales will notify the warehouse to stick. (X01H00-2136I待要出貨時業務會再通知倉庫加貼.)

12	2	R01G50-0012I	WARNING LABEL
11	2	X01C32-1198I	SHIPPING LABEL
10	42	R1008-C4321I	CARTON
9	50M	R1008-8064I	PET FILM
8	20M	R1008-T9998I	PET STRAP
7	2	R1008-C8851I	EDGE PROTECTOR
6	2	R1008-C8852I	EDGE PROTECTOR
5	42	R01951-0204I	G/P LABEL
4	42	X01H00-2136I	CARTON LABEL (出貨時業務再通知倉庫加貼)
3	42	X01H00-1749I	CARTON LABEL
2	336	X01H00-2035I	CARTON BARCODE LABEL
1	1	R1008-P9789I	PALLET
NO.	Q'TY	PART NO.	DESCRIPTION

AcBel ACBEL POLYTECH INC.		MODEL NO. FSE052-00CG	
		PART NO. PA-FSE052-00CG	
		DWG. NO: PA-FSE052-00CG_A	
 THIRD ANGLE PROJECTION 		TITLE PALLET ASS'Y FOR FSE052-00CG	
		DESIGNER	YAHUI
SCALE NONE		SHEET 1 OF 1	APPROVED <i>Sum</i> 10/6/20

RELEASE
 正式發行圖面 REV: A
 ENG. *Yahui* APPR. *Sumjion*

REVISIONS		DATE
REV	DESCRIPTION	BY
A	RELEASE	YAHUI 10/06/'20

S:\3000\3000-001\3000-001.dwg 10/06/2010 10:00:00



康舒科技

ACBEL POLYTECH INC.

Safety



Ref. Certif. No.

JPTUV-094096

IEC SYSTEM FOR MUTUAL RECOGNITION OF TEST
CERTIFICATES FOR ELECTRICAL EQUIPMENT
(IECEE) CB SCHEMESYSTEME CEI D'ACCEPTATION MUTUELLE DE
CERTIFICATS D'ESSAIS DES EQUIPEMENTS
ELECTRIQUES (IECEE) METHODE OC

CB TEST CERTIFICATE

CERTIFICAT D'ESSAI OC

Product
Produit

Switching Power Supply

Name and address of the applicant
Nom et adresse du demandeurAcbel Polytech Inc.
No. 159, Sec. 3, Danjin Rd.,
Tamsui Dist., New Taipei City 251 TaiwanName and address of the manufacturer
Nom et adresse du fabricantName and address of the factory
Nom et adresse de l'usine

See additional page(s)

Ratings and principal characteristics
Valeurs nominales et caractéristiques principalesInput: 1) AC 100-127V; 50/60Hz; 10.0A, AC 200-240V; 50/60Hz; 5.0A
or DC 240V; 5A MAX. or AC 100-240V; 50/60Hz; 10.0-5.0A
for other ratings, refer to the test report, Class I
Output: refer to the test reportTrademark (if any)
Marque de fabrique (si elle existe)Type of Manufacturer's Testing Laboratories used
Type de programme du laboratoire d'essais constructeur

CTF Stage 1

Model / Type Ref.
Ref. de type1) R1CA2801A, R1CA2801B
2) R1CA2551B, R1CA2551CAdditional information (if necessary may also be
reported on page 2)
Les informations complémentaires (si nécessaire,
peuvent être indiqués sur la 2^{ème} page)

For model differences, refer to the test report.

A sample of the product was tested and found
to be in conformity with
Un échantillon de ce produit a été essayé et a été
considéré conforme à laIEC 62368-1:2014
See Test Report for National DifferencesAs shown in the Test Report Ref. No. which forms part
of this Certificate
Comme indiqué dans le Rapport d'essais numéro de
référence qui constitue partie de ce Certificat

50214655 001

This CB Test Certificate is issued by the National Certification Body
Ce Certificat d'essai OC est établi par l'Organisme National de CertificationTÜV Rheinland Japan Ltd.
Global Technology Assessment Center
4-25-2 Kita-Yamata, Tsuzuki-ku
Yokohama 224-0021 Japan
Phone + 81 45 914-3888
Fax + 81 45 914-3354
Mail: info@jpn.tuv.com
Web: www.tuv.com

Date: 29.01.2019

Signature:

Dipl.-Ing. F. Stoelzel

1. Acbel Electronic (Dong Guan)
Co., Ltd.
No. 17-28, Hong Yeh Road, Hong
Yeh Ind. District, Tang Xia Town
Dongguan, Guangdong 523710, P. R. China

2. Acbel Polytech Inc.
No. 159, Sec. 3, Danjin Rd.,
Tamsui Dist., New Taipei City 251
Taiwan

3. AcTel Electronic (Dong Guan) Co., Ltd.
No. 13-16, Hong Yeh 11 Rd.
Hong Yeh Industrial District
Tang Xia Town Dong Guan City,
Guang Dong, P. R. China

4. ACBEL ELECTRONIC (WUHAN) CO., LTD
No. 1, DuTai North Road
Economic Development Zone
XianTao City, HuBei Province
P. R. China

5. Acbel Polytech(Philippines) INC.
No. 2 Tagaytay Ridge Drive,
Carmelray Industrial Park II,
Km. 54 National Highway,
Calamba City, Laguna 4027, Philippines

Additional information (if necessary)
Information complémentaire (si nécessaire)

Report Ref. No.: 50214655 001

Date: 29.01.2019

Signature:

Dipl.-Ing. F. Stoezel

Acbel Polytech Inc.
Mr. Howard Lin Safety Engineer
Safety. DQ Dept.
No. 159, Sec. 3, Danjin Rd.,
Tamsui Dist., New Taipei City 251
Taiwan

Date : 20.02.2019
Our ref. : KKC ZTW1
Your ref.: 12111630/HL291118

Ref : R TÜV-Mark Approval

Type of Equipment : Switching Power Supply
Model Designation : See Certificate
Certificate No. : R 50429841 0001
Report No. : 50214657 001

Dear Mr. Howard Lin,

The above specified equipment has been tested and found to be in accordance with the relevant requirements.

Please find enclosed your certificate as specified above.

If cancellation of the certificate is submitted by 15 November in a given year, no fee will be charged for the following year.

The certificate is issued with the reservation that the license holder applies all information required in § 6 of the ProdSG related to name and address of the manufacturer or his authorized representative / importer, including their respective contact addresses on the product prior to marketing of the product in the European Economic Area.

With kind regards,

Certification Body

Dipl.-Ing. F. Stoelzel

Enclosure

TÜV RHEINLAND TAIWAN LTD.

11F., No. 758, Sec. 4, Bade Rd.,
Songshan Dist., Taipei City 105,
Taiwan R. O. C.
Tel. (02) 2172-7000
Fax (02) 2172-1322
<http://www.tuv.com>

TAICHUNG BRANCH:
No. 9, Lane 36, Sec. 3, Minsheng Rd.,
Daya Dist., Taichung City 428,
Taiwan, R. O. C.
Tel. (04) 2521-8888
Fax (04) 2521-8899

KAOSHIUNG BRANCH:
27F-3, No.80, Minzu 1st Rd.,
Sanmin Dist., Kaohsiung City 807,
Taiwan, R. O. C.
Tel. (07) 262-6000
Fax (07) 380-0577

Zertifikat

Certificate



Zertifikat Nr. *Certificate No.*
R 50429841

Blatt *Sheet*
0001

Ihr Zeichen *Client Reference*
12111630/HL291118

Unser Zeichen *Our Reference*
ZTW1-KKC-50214657 001

Ausstellungsdatum *Date of Issue*
20.02.2019
(day/mo/yr)

Genehmigungsinhaber *License Holder*
Acbel Polytech Inc.
No. 159, Sec. 3, Danjin Rd.,
Tamsui Dist., New Taipei City 251
Taiwan

Fertigungsstätte *Manufacturing Plant*
Refer to latest revision
of the annex list of factories

Prüfzeichen *Test Mark*



Regelmäßige
Produktions-
überwachung
Sicherheit
Bauart geprüft

www.tuv.com
ID 1419066415

Geprüft nach *Tested acc. to*
EN 62368-1:2014+A11

Zertifiziertes Produkt (Geräteidentifikation)
Certified Product (Product Identification)

Lizenzentgelte - Einheit
License Fee - Unit

Einbauschaltnetzteil (Switching Power Supply)

Bezeichnung : FSE052 (AcBel) 10
(Type Designation)

Eingang : AC 100-127V; 50/60Hz; 10.0A,
(Input) AC 200-240V; 50/60Hz; 5.0A oder (or)
DC 240V; 5A MAX oder (or)
AC 100-240V; 50/60Hz; 10.0-5.0A

Ausgang : DC +12.0V/66.7A, +12Vsb/3.0A
(Output)

max. Ausgangsleistung (max. Output Power) : 800W
max. Umgebungstemperatur (max. Ambient Temperature): 50°C
Schutzklasse (Protection Class) : I
Verschmutzungsgrad (Pollution Degree) : 2
max. Betriebshöhe (max. Operating Altitude) : 5,000m

10

ANLAGE (Appendix) : 1

Dem Zertifikat liegt unsere Prüf- und Zertifizierungsordnung zugrunde und es bestätigt die Konformität des Produktes mit den oben genannten Standards und Prüfgrundlagen. Zusätzliche Anforderungen in Ländern, in denen das Produkt in Verkehr gebracht werden soll, müssen zusätzlich betrachtet werden. Die Herstellung des zertifizierten Produktes wird überwacht.

This certificate is based on our Testing and Certification Regulation and states the conformity of the product with the standards and testing requirements as indicated above. Any additional requirements in countries where the product is going to be marketed have to be considered additionally. The manufacturing of the certified product is subject to surveillance.

TÜV Rheinland LGA Products GmbH, Tillystraße 2, 90431 Nürnberg

Tel.: +49 221 806-1371 e-mail: cert-validity@de.tuv.com
Fax: +49 221 806-3935 http://www.tuv.com/safety

Zertifizierungsstelle



Dipl.-Ing. F. Stölzel

**Anlage Fertigungsstättenliste
/Attachment List of Factories**



R 50429841 0001

1 Acbel Electronic (Dong Guan)
Co., Ltd.
No. 17-28, Horng Yeh Road, Horng
Yeh Ind. District, Tang Xia Town
Dongguan, Guangdong 523710
P. R. China

2 Acbel Polytech Inc.
No. 159, Sec. 3, Danjin Rd.,
Tamsui Dist., New Taipei City 251
Taiwan

3 AcTel Electronic (Dong Guan) Co., Ltd.
No. 13-16, Hong Yeh 11Rd.
Hong Yeh Industrial District
Tang Xia Town Dong Guan City,
Guang Dong
P. R. China

4 ACBEL ELECTRONIC (WUHAN) CO., LTD
No. 1, DuTai North Road
Economic Development Zone
XianTao City, HuBei Province
P. R. China

5 Acbel Polytech(Philippines) INC.
No. 2 Tagaytay Ridge Drive,
Carmelray Industrial Park II,
Km. 54 National Highway,
Calamba City, Laguna 4027
Philippines

Dieser Anhang ersetzt den Vorgänger vom/
This annex replaces the previous annex dated

Datum / Date 20.02.2019

Zertifizierungsstelle
/ Certification Body

Dipl.-Ing. F. Stöelzel



Zertifikat

Certificate



Zertifikat Nr. *Certificate No.*
R 50429841

Blatt *Sheet*
0002

Ihr Zeichen <i>Client Reference</i>	Unser Zeichen <i>Our Reference</i>	Ausstellungsdatum <i>Date of Issue</i>	<i>(day/mo/yr)</i>
12111630/HL291118	ZTW1-KKC-50214657 001	20.02.2019	

Genehmigungsinhaber *License Holder*
Acbel Polytech Inc.
No. 159, Sec. 3, Danjin Rd.,
Tamsui Dist., New Taipei City 251
Taiwan

Fertigungsstätte *Manufacturing Plant*
Refer to latest revision
of the annex list of factories

Prüfzeichen *Test Mark*



Regelmäßige
Produktions-
überwachung
Sicherheit
Bauart geprüft

www.tuv.com
ID 1419086415

Geprüft nach *Tested acc. to*
EN 62368-1:2014+A11

Zertifiziertes Produkt (Geräteidentifikation)
Certified Product (Product Identification)

Lizenzentgelte - Einheit
License Fee - Unit

Einbauschaltnetzteil (Switching Power Supply)

wie Blatt (as page) 01, Ergänzung (Addition)

Bezeichnung (Type Designation)	: R1CA2801A, FSF037, R1CA2801B (AcBel)	3
	FSF059, R1CA2551B (AcBel)	2
	FSF065, R1CA2551C (AcBel)	2
	FSG007, R1CH2801A (AcBel)	2
	FSG016, R1CH2551A (AcBel)	2

Eingang
(Input) : siehe Aufbau-Übersicht
(see constructional dataform)

Ausgang
(Output) : siehe Aufbau-Übersicht
(see constructional dataform)

11

ANLAGE (Appendix): 1

Dem Zertifikat liegt unsere Prüf- und Zertifizierungsordnung zugrunde und es bestätigt die Konformität des Produktes mit den oben genannten Standards und Prüfgrundlagen. Zusätzliche Anforderungen in Ländern, in denen das Produkt in Verkehr gebracht werden soll, müssen zusätzlich betrachtet werden. Die Herstellung des zertifizierten Produktes wird überwacht.
This certificate is based on our Testing and Certification Regulation and states the conformity of the product with the standards and testing requirements as indicated above. Any additional requirements in countries where the product is going to be marketed have to be considered additionally. The manufacturing of the certified product is subject to surveillance.

TÜV Rheinland LGA Products GmbH, Tillystraße 2, 90431 Nürnberg

Tel.: +49 221 806-1371 e-mail: cert-validity@de.tuv.com
Fax: +49 221 806-3935 http://www.tuv.com/safety

Zertifizierungsstelle



Dipl.-Ing. F. Stöckel

CERTIFICATE OF COMPLIANCE

Certificate Number 20190220-E131875
Report Reference E131875-20190219
Issue Date 2019-FEBRUARY-20

Issued to: ACBEL POLYTECH INC
No159 Sec 3 Danjin Rd
TamSui District
New Taipei 251 TAIWAN

**This certificate confirms that
representative samples of**

COMPONENT - POWER SUPPLIES FOR USE WITH
AUDIO/VIDEO, INFORMATION AND COMMUNICATION
TECHNOLOGY EQUIPMENT

SWITCHING POWER SUPPLY Model

- (1) FSE052, R1CA2801A, FSF037, R1CA2801B
- (2) FSF059, R1CA2551B, FSF065, R1CA2551C

Have been investigated by UL in accordance with the component requirements in the Standard(s) indicated on this Certificate. UL Recognized components are incomplete in certain constructional features or restricted in performance capabilities and are intended for installation in complete equipment submitted for investigation to UL LLC.

Standard(s) for Safety:

UL 62368-1 and CAN/CSA C22.2 No.62368-1-14
Audio/video, information and communication technology
equipment – Part 1: Safety requirements

Additional Information:

See the UL Online Certifications Directory at
<https://iq.ulprospector.com> for additional information.

This *Certificate of Compliance* does not provide authorization to apply the UL Recognized Component Mark. Only the UL Follow-Up Services Procedure provides authorization to apply the UL Mark.

Only those products bearing the UL Recognized Component Mark should be considered as being UL Certified and covered under UL's Follow-Up Services.

Look for the UL Recognized Component Mark on the product.



Bruce Mahrenholz, Director North American Certification Program

UL LLC

Any information and documentation involving UL Mark services are provided on behalf of UL LLC (UL) or any authorized licensee of UL. For questions, please contact a local UL Customer Service Representative at <http://ul.com/aboutul/locations/>



Declaration of Conformity

For the following equipment :

Product : Switching Power Supply
Type Designation : FSE052, R1CA2801A, FSF037, R1CA2801B,
FSF059, R1CA2551B, FSF065, R1CA2551C
Trademark : 
Manufacturer's Name : ACBEL POLYTECH INC
Manufacturer's Address : No.159, Sec. 3, Danjin Rd., Tamsui Dist., New Taipei City, Taiwan

Is herewith confirmed to comply with the following legal requirements set out in the Official Journal of the European Union. Products sold in the European Economic Area (EEA) have been assessed to meet high safety, health, and environmental protection requirements.

- Low-Voltage Directive EN 62368 -1:2014+A11:2017
2014/35/EU :
- EMC Directive EN 55032:2015 ; EN 55024:2010 ;
2014/30/EU : EN 61000-3-2:2014 ; EN 61000-3-3:2013
- RoHS Directive EN 50581:2012
2011/65/EU
((EU) 2015/863) :
- Additional information : DECISION No 768/2008/EC

Responsible for making this declaration is the :

- Manufacturer
 Authorized representative established within the EU
 Authorized representative established within the EU (if applicable) :

Company Name : _____
Company Address : _____

Person responsible for making this declaration

Name , Surname : Howard Lin
Position / Title : Safety Supervisor / Acbel Polytech Inc.

Taipei , Taiwan
Place

2020-12-14
Date

Legal Signature

UK Declaration of Conformity

For the following equipment :

Product : Switching Power Supply
Type Designation : FSE052, R1CA2801A, FSF037, R1CA2801B, FSF059,
R1CA2551B, FSF065, R1CA2551C
Trademark : 
Manufacturer's Name : ACBEL POLYTECH INC.
Manufacturer's Address : No.159, Sec. 3, Danjin Rd., Tamsui Dist., New Taipei City, Taiwan

Is herewith confirmed to comply with the following legal requirements. Products sold in the Great Britain (GB) have been assessed to meet high safety, health, and environmental protection requirements.

- Electrical Equipment (Safety) Regulations 2016 : BS EN 62368-1:2014 +A11:2017
- Electromagnetic Compatibility Regulations 2016 : BS EN 55032:2015 ; BS EN 55024:2010 ;
BS EN 61000-3-2:2014 ; BS EN 61000-3-3:2013
- The Ecodesign for Energy-Related Products and Energy Information (Amendment) (EU Exit) Regulations 2019 : BS EN 50563:2011/A1:2013
- The Restriction of the Use of Certain Hazardous Substances in Electrical and Electronic Equipment Regulations 2012 : BS EN 50581:2012

Responsible for making this declaration is the :

- Manufacturer
 Authorized representative established within the UK
 Authorized representative established within the UK (if applicable) :

Company Name : _____
Company Address : _____

Person responsible for making this declaration

Name , Surname : Howard Lin/ Acbel Polytech Inc
Position / Title : Safety Supervisor

Taipei , Taiwan
Place

2021-03-26
Date

Legal Signature



經濟部標準檢驗局

BUREAU OF STANDARDS, METROLOGY AND INSPECTION,
MINISTRY OF ECONOMIC AFFAIRS



商品驗證登錄電子證書

CERTIFICATE OF THE REGISTRATION OF PRODUCT CERTIFICATION

證書號碼： CI334065675512 號 99

Certificate No.

茲據 康舒科技股份有限公司

申請驗證登錄，經審查結果符合規

定，准予登錄並使用商品安全標章及識別號碼：

R33567

。其登錄事項如下：

The application made by

for Registration of Product

Certification has been reviewed and found to be in compliance with related regulations. Therefore, registration is granted with the

Product Safety Mark and the Identification No.

R33567

. Details of the registration are follows :

申請人：康舒科技股份有限公司

統一編號：12341051

Applicant

Uniform No.

地址：台北市松山區南京東路5段99號11樓

Address

生產廠場：詳如附表

Factory

廠址：詳如附表

Factory Address

商品種類名稱：

Type/name of product

商品分類號列：8504.40.91.00.7-A

C.C.C Code

中文名稱：交換式電源供應器

Chinese name

英文名稱：Switching Power Supply

English name

型式：FSE052

Type

系列型式：FSF037, R1CA2801A, R1CA2801B(以下空白)

Series of the type

依據標準：CNS13438 (095/06/01年版)、CNS14336-1 (099/09/30年版)、符合CNS 15663

Standards 第5節「含有標示」規定。102年版

標準檢驗局發證(發證地址：100臺北市中正區濟南路1段4號)

This certificate is issued by the BSMI. (No.4, Sec. 1, Jinan Rd., Zhongzheng Dist., Taipei City 100, Taiwan)

本證書以電子文件行之，所載內容若有不符之處，以標準局電腦資料為主，查詢驗證資料

網址：<http://bsmi.gov.tw>

登錄日期：中華民國	104	年	10	月	29	日
Registration Date	2015	(year)	10	(month)	29	(day)
本證書有效期限至	110	年	10	月	28	日
Expiration Date	2021	(year)	10	(month)	28	(day)
發證日期：中華民國	107	年	08	月	22	日
Date of issue	2018	(year)	08	(month)	22	(day)



註1：持本證書進口驗證登錄商品時，進口人須與本證書名義人相同。

註2：次年度商品驗證登錄年費繳納期限為當年11月30日，逾期未繳納者，經限期繳納屆期未繳納，即依商品檢驗法第42條第7款規定廢止驗證登錄，並自次年度1月1日起生效。

經濟部標準檢驗局

BUREAU OF STANDARDS, METROLOGY AND INSPECTION,
MINISTRY OF ECONOMIC AFFAIRS

商品驗證登錄電子證書

CERTIFICATE OF THE REGISTRATION OF PRODUCT CERTIFICATION

證書號碼： CI334065675512 號 99

Certificate No.

- 生產廠場：
Factory：
1. ACBEL ELECTRONIC (WUHAN) CO., LTD / 康舒電子(武漢)有限公司
No.1, DuTai North Road, Economic Development Zone, XianTao City, HuBei Province, People's Republic Of China/ 湖北省仙桃市經濟開發區杜台北路1號
 2. AcTel Electronic (Dong Guan) Co., Ltd. / 康展電子(東莞)有限公司
No. 13-16, Hong Yeh 11 Rd., Hong Yeh Industrial District, Tang Xia Town, DongGuan City, Guang Dong, P.R. China/ 廣東省東莞市塘廈鎮宏業工業區宏業11路13-16號
 3. Acbel Polytech Inc. / 康舒科技股份有限公司
No.159, Sec. 3, Danjin Rd., Tamsui Dist., New Taipei City 251, Taiwan/ 新北市淡水區淡金路3段159號
 4. Acbel Polytech (Philippines) Inc.
No. 2 Tagaytay Ridge Drive, Carmelray Industrial Park II, Km. 54 National Highway, Calamba City, Laguna 4027, Philippines
 5. Acbel Electronic (Dong Guan) Co., Ltd. / 康舒電子(東莞)有限公司
No. 17-28, Horng Yeh Road, Horng Yeh Ind. District, Tang Xia Town, Dongguan, Guangdong 523710, P.R. China/ 廣東省東莞市塘廈鎮宏業工業區宏業大道17-28號

(以下空白)



中国国家强制性产品认证证书

证书编号：2015010907793861

委托人名称、地址

康舒科技股份有限公司
中国台北市松山区南京东路5段99号11楼

生产者（制造商）名称、地址

康舒科技股份有限公司
中国台北市松山区南京东路5段99号11楼

生产企业名称、地址

康舒电子（东莞）有限公司
广东省东莞市塘厦镇宏业工业区宏业大道17-28号

产品名称和系列、规格、型号

开关电源

FSE052、R1CA2801A、FSF037、R1CA2801B 输入：100-127Vac, 10.0A, 50/60Hz; 200-240Vac, 5.0A, 50/60Hz 或 240Vdc, 5A MAX. 或 100-240V~, 50/60Hz, 10.0-5.0A 输出：DC +12.0V/66.7A, +12Vsb/3.0A, 最大输出功率：800W; FSF059、R1CA2551B、FSF065、R1CA2551C 输入：100-127Vac, 50/60Hz, 7.0A; 200-240Vac, 50/60Hz, 3.5A 或 240VDC, 3.5A MAX. 输出：DC+12.0V/45.8A, +12Vsb/3.0A, 最大输出功率：550W (仅适用于海拔 5000 米及以下)(不带电线组件销售)

产品标准和技术要求

GB 17625.1-2012; GB 4943.1-2011; GB/T 9254-2008

上述产品符合强制性产品认证实施规则 CNCA-C09-01:2014 的要求，
特发此证。

发证日期：2020年07月13日 有效期至：2025年07月13日
证书有效期内本证书的有效性依据发证机构的定期监督获得保持。

本证书为变更证书，证书首次颁发日期：2015年07月31日

本证书的相关信息可通过国家认监委网站 www.cnca.gov.cn 查询

经中国合格评定国家认可委员会认可 CNAS C001-P



主任：

陆楠

中国质量认证中心



CERTIFICATE FOR CHINA COMPULSORY PRODUCT CERTIFICATION

CERTIFICATE NO.: 2015010907793861

NAME AND ADDRESS OF THE APPLICANT

Acbel Polytech Inc.

11F., No.99, Sec. 5, Nan-King E. Road, Sungshan Chiu, Taipei, Taiwan, Province Of China.

NAME AND ADDRESS OF THE MANUFACTURER

Acbel Polytech Inc.

11F., No.99, Sec. 5, Nan-King E. Road, Sungshan Chiu, Taipei, Taiwan, Province Of China.

NAME AND ADDRESS OF THE FACTORY

Acbel Electronic (Dong Guan) Co., Ltd.

No. 17-28, Horng Yeh Road, Horng Yeh Ind. District, Tang Xia Town, Dongguan, Guangdong 523710, P.R. China

PRODUCT NAME, MODEL AND SPECIFICATION

Switching Power Supply

FSE052、R1CA2801A、FSF037、R1CA2801B 输入: 100-127Vac, 10.0A,50/60Hz; 200-240Vac, 5.0A, 50/60Hz 或 240Vdc, 5A MAX. 或 100-240V~, 50/60Hz, 10.0-5.0A 输出: DC +12.0V/66.7A, +12Vsb/3.0A , 最大输出功率: 800W; FSF059、R1CA2551B、FSF065、R1CA2551C 输入: 100-127Vac, 50/60Hz,7.0A; 200-240Vac, 50/60Hz, 3.5A 或 240VDC, 3.5A MAX. 输出: DC+12.0V/45.8A, +12Vsb/3.0A, 最大输出功率: 550W (仅适用于海拔 5000 米及以下)(不带电线组件销售)

THE STANDARDS AND TECHNICAL REQUIREMENTS FOR THE PRODUCTS

GB 17625.1-2012;GB 4943.1-2011;GB/T 9254-2008

This is to certify that the above mentioned product(s) complies with the requirements of implementation rules for compulsory certification(REFNO.CNCA-C09-01:2014).

Valid from: Jul.13,2020

Valid until: Jul.13,2025

The validity of the certificate is subject to positive result of the regular follow up inspection by issuing certification body until the expiry date.

Date of original issued: Jul.31,2015

The certificate information is available through CNCA's website: www.cnca.gov.cn

Accredited by China National Accreditation Service for Conformity Assessment CNAS C001-P



President:

Lu Mei



CHINA QUALITY CERTIFICATION CENTRE



भारतीय मानक ब्यूरो

(उपभोक्ता मामले, खाद्य एवं सार्वजनिक वितरण मंत्रालय, भारत सरकार)

BUREAU OF INDIAN STANDARDS

(Ministry of Consumer Affairs, Food & Public Distribution,
Govt. of India)

मानक भवन, 9 बहादुर शाह जफर मार्ग, नई दिल्ली - 110002
Manak Bhavan, 9 Bahadur Shah Zafar Marg, New Delhi - 110002
दूरभाष/Phone: +91-11-23230856/2323010131/23233375/23239402
ई-मेल/E-mail: registration@bis.gov.in
वेबसाइट/Website: <https://bis.gov.in/>, <https://www.crsbis.in/BIS/>

Our Ref: REGISTRATION/CRS 2015-0272/R-41013579

Date:19-03-2020

Inclusion Id: 34784

Subject :Inclusion of Additional Model(s)

MANUFACTURING UNIT :	Acbel Electronics (Dong Guan) Co Ltd HORNG YEH INDUSTRIAL DISTRICT TANG XIA TOWN DONGGUAN GUANGDONG CHINA GUANGDONG,China-0 Andy_zhou@apitech.com.tw 8676987915950	
----------------------	---	---

Dear Sir,

1. This has reference to your request for inclusion of models of "Power Adapter for IT Equipment" as per IS 13252(Part 1):2010/ IEC 60950-1 : 2005 in Licence No. R-41013579 already granted to you which is valid upto 15-04-2024.

2. It is intimated that the additional Models as per details given below have been agreed to be included in your scope of Licence. R-41013579 w.e.f. 19-03-2020:

Product	Power Adapter for IT Equipment
IS No.	IS 13252(Part 1):2010/ IEC 60950-1 : 2005
Brand (As Declared by Manufacturer):	ACBEL
Inclusion of Additional Models (w.e.f. 19-03-2020)	FSE052,FSF037
Factory Address	HORNG YEH INDUSTRIAL DISTRICT TANG XIA TOWN DONGGUAN GUANGDONG CHINA GUANGDONG,China-0

3. Other terms and conditions of the licence shall remain same.

4. This letter is being issued with the approval of competent authority.

Kindly acknowledge receipt of this letter.

Thanking you,

Yours faithfully,
(Supriya Minz)
Sc. C
Telfax : +91-11-23230856
E-mail: registration@bis.gov.in

Note: This is a system generated letter. Hence signature is not required.
To verify authentication of letter, kindly scan the QR code on this letter.



안전확인신고증명서 Confirmation Letter of Declaration

신고번호: XU100121-16156B
 (Application No.)
신고회사명: Acbel Electronic (Dongguan) Co.,Ltd.
 (Applicant)
주소: No.17-28 (Hong Yeh Rd) Hong Yeh Industrial District, Tang Xia
 (Address) Town, Dongguan, Guangdong, China
제품명: 컴퓨터용 전원공급장치
 (Product)
기본모델명: FSE052
 (Basic Model)
파생모델명 (Series Model):
 R1CA2801A FSF037
 R1CA2801B

정격/안전기준상의 모델구분: I/P: 100-127 V~, 50/60 Hz, 10.0 A; 200-240 V~, 50/60
 (Rating) Hz, 5.0 A or 240 Vdc, 5 A MAX.
안전기준: K 60950-1(2011-12)
 (Standard)

본 확인신고는 **제조국명:** 중국
제조업자명: Acbel Electronic (Dongguan) Co.,Ltd.
제조공장의 주소: No.17-28 (Hong Yeh Rd) Hong Yeh Industrial District, Tang Xia
 Town, Dongguan, Guangdong, China
 의 제품에만 해당함

「전기용품 및 생활용품 안전관리법 시행규칙」 제27조제1항·제3항 또는 제28조제2항에 따라 안전확인신고 증명서를 발급합니다.
 We issue this Confirmation Letter of Declaration of the Safety Confirmation for the above appliances in accordance with Article 27(1), 27(3) or 28(2) of the Electrical Appliances and Consumer Products Safety Control Act.

2018 년 05 월 18 일
 (Year) (Month) (Day)



한국기계전기전자시험연구원장
Korea Testing Certification



※ 이 신고증명서는 「전기용품 및 생활용품 안전관리법」에 따른 제품의 안전성 확인에 한정된 것이며, 그 밖의 다른 법률이 적용되는 제품의 경우에는 해당 법률에 따라 추가로 인증·허가 등을 받아야 합니다.

첨부서류	1. 전기용품의 안전관리부품 및 재질목록 (List of Critical Components)(전기용품에 한정한다) 2. 기본모델·파생모델의 내용 (Descriptions of the basic and series model) 3. 안전확인신고 내용의 변경 현황 (Revisions Status)
-------------	---

기술 문서 Technical Document

page: 1 / 11

안전인증번호: XU100121-16156B
(Certificate No)

접수번호: 20180509 - 0024
(Receipt No)

1. 기본모델 · 파생모델의 내용 (General Descriptions of Certified Products)

1.1 제품의 설명 (Product description)

인증제품의 개요는 다음과 같다.

(Information on certified basic model product is as follow)

구분 (Section)	내용 (Description)
용도 (Normal use)	Switching power supplies with metal chassis for the use into IT equipment.
내부구조 (Internal construction)	Consist of switching transformer, rectifying part, etc.
외부구조 (External construction)	Provided tieh metalic enclosure and appliance inlet.
기타(Others)	(O/P: DC +12.0 V/66.7 A, +12 Vsb/3.0 A, Total power 800W MAX.) Class I, CB Test Certifiante is issued by TUV Rheinland (JPTUV-087341).

1.2 전기용품의 표시: 전기용품 및 생활용품 안전관리법 시행규칙 제35조(안전확인대상제품의 표시)에 따라 표시한다.

(Marking of KC Mark: Marking shall comply with the Article 35 of the Enforcement Rule of the Electrical Appliances and Consumer Products Safety Control Act.)

1.3 등록모델 (Registered Models)

구분 (Class)	모델명 및 정격 (Model / Rating)	기본모델과의 차이점 (Difference between basic model and series model)
기본모델 (Basic model)	FSE052 I/P: 100-127 V~, 50/60 Hz, 10.0 A; 200-240 V~, 50/60 Hz, 5.0 A or 240 Vdc, 5 A MAX.	
파생모델 (Series model)	R1CA2801A	Identical to basic model except for model designation.
	FSF037	Similar to basic model except for direction of DC Fan.
	R1CA2801B	Similar to basic model except for direction of DC Fan.



기술 문서 Technical Document

page: 2 / 11

안전인증번호: XU100121-16156B
(Certificate No)

접수번호: 20180509 - 0024
(Receipt No)

2. 안전관리 부품 및 재질목록(List of Critical Components)

부품명(회로기호) Components(Part no.)	제조사(상표명) Manufacturer(Brand)	모델명(형식) Model(Type)	정격 또는 특성 (Technical Data)	인증규격 (Certification)
Inlet	Tecx-Unions Technology Corp.	TU-301 series (-A/AP/AP-A/S/SP)	10 A, 250 Vac; 10 A, 250 Vdc (TUV)	IEC
Inlet (Alt.)	Inalways Corp (International All Ways Ind Co Ltd)	0711 series	10 A, 250 Vac; 10 A, 250 Vdc (TUV) 3.5 A, 360 Vdc (TUV)	IEC
Inlet (Alt.)	Rong Feng Industrial Co Ltd	SS-120	10 A, 250 Vac; 10 A, 250 Vdc (TUV)	IEC
Inlet (Alt.)	Sheng Ming Enterprise Co., Ltd.	S14-102	10 A, 250 Vdc (TUV)	IEC
Fuse (F1)	Hollyland Co Ltd	50CF	F 15 A, 250 V	IEC
Fuse (F1) (Alt.)	Littelfuse Inc (Littelfuse Ltd, Suzhou Littelfuse OVS Ltd, Littelfuse B V)	487 Series	F 15 A, 420 Vac/dc	IEC
Fuse (F201)	Conquer Electronics Co Ltd	PBU	F 1 A, 250 Vac	IEC
Fuse (F3)	Conquer Electronics Co Ltd	PGU	F 6.3 A, 250 Vac	IEC
Fuse (F3) (Alt.)	Conquer Electronics Co., Ltd.	PBU	F 6.3 A, 250 Vac	IEC
Fuse (F3) (Alt.)	WALTER ELECTRONIC CO LTD	FDP	F 6.3 A, 250 Vac	IEC
X-Capacitor (C4, C7)	Arcotronics Italia SPA	R.46	250 Vac min., 110 °C C4 = 1 µF, C7 = 0.47 µF (X2 type)	IEC
X-Capacitor (C4, C7) (Alt.)	Hua Jung Components Co Ltd	MKP	250 Vac min., 110 °C C4 = 1 µF, C7 = 0.47 µF (X2 type)	IEC
X-Capacitor (C4, C7) (Alt.)	SHENZHEN JINGHAO CAPACITOR CO LTD	CBB62B	250 Vac min., 110 °C C4 = 1 µF, C7 = 0.47 µF (X2 type)	IEC
X-Capacitor (C4, C7) (Alt.)	YIMANFENG SCIENCE AND TECHNOLOGY LTD CO	MPX/MKP	250 Vac min., 110 °C C4 = 1 µF, C7 = 0.47 µF (X2 type)	IEC

[서식 CP401-18-00]



기술문서 Technical Document

page: 3 / 11

안전인증번호: XU100121-16156B
(Certificate No)

접수번호: 20180509 - 0024
(Receipt No)

부품명(회로기호) Components(Part no.)	제조사(상표명) Manufacturer(Brand)	모델명(형식) Model(Type)	정격 또는 특성 (Technical Data)	인증규격 (Certification)
X-Capacitor (C4, C7) (Alt.)	Okaya Electric Industries Co., Ltd	XF	250 Vac min., 110 °C C4 = 1 μ F, C7 = 0.47 μ F (X2 type)	IEC
X-Capacitor (C4, C7) (Alt.)	Strong Capacitor Co. Ltd.	Type MPX	250 Vac min., 110 °C C4 = 1 μ F, C7 = 0.47 μ F (X2 type)	IEC
X-Capacitor (C4, C7) (Alt.)	Vishay Capacitors Belgium NV	F1778	250 Vac min., 110 °C C4 = 1 μ F, C7 = 0.47 μ F (X2 type)	IEC
X-Capacitor (C4, C7) (Alt.)	ZHUHAI SUNG HO ELECTRONICS CO LTD	CMPP	250 Vac min., 105 °C; C4 = 1 μ F, C7 = 0.47 μ F (X2 type)	IEC
X-Capacitor (C4, C7) (Alt.)	Okaya Electric Industries Co., Ltd	RE series	250 Vac min., 100 °C, C4 = 1 μ F, C7 = 0.47 μ F (X2 type)	IEC
X-Capacitor (C4, C7) (Alt.)	Okaya Electric Industries Co Ltd	LE series	250 Vac min., 100 °C, C4 = 1 μ F, C7 = 0.47 μ F (X2 type)	IEC
X-Capacitor (C4, C7) (Alt.)	Cheng Tung Industrial Co Ltd	CTX	250 Vac min., 100 °C, C4 = 1 μ F, C7 = 0.47 μ F (X2 type)	IEC
X-Capacitor (C4, C7) (Alt.)	Epcos Electronic Components S.A.	B3292 series	250 Vac min., 100 °C, C4 = 1 μ F, C7 = 0.47 μ F (X2 type)	IEC
X-Capacitor (C4, C7) (Alt.)	Vishay Capacitors Belgium NV	F1772	250 Vac min., 100 °C, C4 = 1 μ F, C7 = 0.47 μ F (X2 type)	IEC
X-Capacitor (C4, C7) (Alt.)	KEMET ELECTRONICS OY(Evox Rifa Group Oyj)	PHE840M	250 Vac min., 100 °C, C4 = 1 μ F, C7 = 0.47 μ F (X2 type)	IEC
X-Capacitor (C4, C7) (Alt.)	Carli Electronics Co Ltd	MPX	250 Vac min., 100 °C, C4 = 1 μ F, C7 = 0.47 μ F (X2 type)	IEC
X-Capacitor (C4, C7) (Alt.)	Panasonic Corporation	ECQUL	250 Vac min., 100 °C, C4 = 1 μ F, C7 = 0.47 μ F (X2 type)	IEC
X-Capacitor (C4, C7) (Alt.)	SHENZHEN SURONG CAPACITORS CO LTD	MPX/MKP	250 Vac min., 100 °C, C4 = 1 μ F, C7 = 0.47 μ F (X2 type)	IEC
Y-Capacitor (C198, C199, C5, C6)	Murata Mfg Co Ltd	KX	250 Vac min., 125 °C, C198, C199 = 2200 pF, C5, C6 = 3300 pF (Y2 type)	IEC
Y-Capacitor (C198, C199, C5, C6) (Alt.)	TDK-EPC Corporation	CD	250 Vac min., 125 °C, C198, C199 = 2200 pF, C5, C6 = 3300 pF (Y2 type)	IEC

[서식 CP401-18-00]



기술문서 Technical Document

page: 4 / 11

안전인증번호: XU100121-16156B
(Certificate No)

접수번호: 20180509 - 0024
(Receipt No)

부품명(회로기호) Components(Part no.)	제조사(상표명) Manufacturer(Brand)	모델명(형식) Model(Type)	정격 또는 특성 (Technical Data)	인증규격 (Certification)
Y-Capacitor (C198, C199, C5, C6) (Alt.)	Walsin Technology Corp (Pan Overseas Electronic Co Ltd)	AH	250 Vac min., 125 ℃, C198, C199 = 2200 pF, C5, C6 = 3300 pF (Y2 type)	IEC
Y-Capacitor (C198, C199, C5, C6) (Alt.)	Success Electronics Co Ltd	SE	250 Vac min., 125 ℃, C198, C199 = 2200 pF, C5, C6 = 3300 pF (Y2 type)	IEC
Y-Capacitor (C198, C199, C5, C6) (Alt.)	Vishay Electronic GMBH Draloric for VDE; (Roederstein Electronics Inc)	VY1	250 Vac min., 125 ℃, C198, C199 = 2200 pF, C5, C6 = 3300 pF (Y2 type)	IEC
Y-Capacitor (C198, C199, C5, C6) (Alt.)	JERRO ELECTRONICS CORP	JX	250 Vac min., 125 ℃, C198, C199 = 2200 pF, C5, C6 = 3300 pF (Y2 type)	IEC
Y-Capacitor (C198, C199, C5, C6) (Alt.)	Holy Stone Enterprise Co., Ltd.	SDC series	250 Vac min., 125 ℃, C198, C199 = 2200 pF, C5, C6 = 3300 pF (Y2 type)	IEC
Y-Capacitor (C198, C199, C5, C6) (Alt.)	Success Electronics Co Ltd	SB	250 Vac min., 125 ℃, C198, C199 = 2200 pF, C5, C6 = 3300 pF (Y2 type)	IEC
Y-Capacitor (C198, C199, C5, C6) (Alt.)	YINAN DON'S ELECTRONIC COMPONENT CO LTD	CT81	250 Vac min., 125 ℃, C198, C199 = 2200 pF, C5, C6 = 3300 pF (Y2 type)	IEC
Y-Capacitor (C198, C199, C5, C6) (Alt.)	NAN JING YUYUE ELECTRONICS CO LTD	CT7	250 Vac min., 125 ℃, C198, C199 = 2200 pF, C5, C6 = 3300 pF (Y2 type)	IEC
Y-Capacitor (C198, C199, C5, C6) (Alt.)	Murata Mfg Co Ltd	KH	250 Vac min., 125 ℃, C198, C199 = 2200 pF, C5, C6 = 3300 pF (Y2 type)	IEC
Y-Capacitor (C198, C199, C5, C6) (Alt.)	TDK-EPC Corporation	CS	250 Vac min., 125 ℃, C198, C199 = 2200 pF, C5, C6 = 3300 pF (Y2 type)	IEC
Y-Capacitor (C198, C199, C5, C6) (Alt.)	Walsin Technology Corp (Pan Overseas Electronic Co Ltd)	AC	250 Vac min., 125 ℃, C198, C199 = 2200 pF, C5, C6 = 3300 pF (Y2 type)	IEC
Y-Capacitor (C198, C199, C5, C6) (Alt.)	Success Electronics Co Ltd	SF	250 Vac min., 125 ℃, C198, C199 = 2200 pF, C5, C6 = 3300 pF (Y2 type)	IEC
Y-Capacitor (C198, C199, C5, C6) (Alt.)	Vishay Electronic GMBH Draloric (Roederstein Electronics Inc)	VY2	250 Vac min., 125 ℃, C198, C199 = 2200 pF, C5, C6 = 3300 pF (Y2 type)	IEC
Y-Capacitor (C198, C199, C5, C6) (Alt.)	JERRO ELECTRONICS CORP	JL	250 Vac min., 125 ℃, C198, C199 = 2200 pF, C5, C6 = 3300 pF (Y2 type)	IEC

[서식 CP401-18-00]



기술문서 Technical Document

page: 5 / 11

안전인증번호: XU100121-16156B
(Certificate No)

접수번호: 20180509 - 0024
(Receipt No)

부품명(회로기호) Components(Part no.)	제조사(상표명) Manufacturer(Brand)	모델명(형식) Model(Type)	정격 또는 특성 (Technical Data)	인증규격 (Certification)
Y-Capacitor (C198, C199, C5, C6) (Alt.)	Murata Mfg Co Ltd	KY	250 Vac min., 125 °C, C198, C199 = 2200 pF, C5, C6 = 3300 pF (Y2 type)	IEC
Bridge Capacitor (C17)	Murata Mfg Co Ltd	KX	250 Vac min., 125 °C, C17 = 2200 pF (Y1 type)	IEC
Bridge Capacitor (C17) (Alt.)	TDK-EPC Corporation	CD	250 Vac min., 125 °C, C17 = 2200 pF (Y1 type)	IEC
Bridge Capacitor (C17) (Alt.)	Walsin Technology Corp (Pan Overseas Electronic Co Ltd)	AH	250 Vac min., 125 °C, C17 = 2200 pF (Y1 type)	IEC
Bridge Capacitor (C17) (Alt.)	Success Electronics Co Ltd	SE	250 Vac min., 125 °C, C17 = 2200 pF (Y1 type)	IEC
Bridge Capacitor (C17) (Alt.)	Vishay Electronic GMBH Draloric (Roederstein Electronics Inc)	VY1	250 Vac min., 125 °C, C17 = 2200 pF (Y1 type)	IEC
Bridge Capacitor (C17) (Alt.)	Holy Stone Enterprise Co., Ltd.	SDC series	250 Vac min., 125 °C, C17 = 2200 pF (Y1 type)	IEC
Bridge Capacitor (C17) (Alt.)	Success Electronics Co Ltd	SB	250 Vac min., 125 °C, C17 = 2200 pF (Y1 type)	IEC
Bridge Capacitor (C17) (Alt.)	YINAN DON'S ELECTRONIC COMPONENT CO LTD	CT81	250 Vac min., 125 °C, C17 = 2200 pF (Y1 type)	IEC
Bridge Capacitor (C17) (Alt.)	JERRO ELECTRONICS CORP	JX	250 Vac min., 125 °C, C17 = 2200 pF (Y1 type)	IEC
Bridge Capacitor (C17) (Alt.)	NAN JING YUYUE ELECTRONICS CO LTD	CT7	250 Vac min., 125 °C, C17 = 2200 pF (Y1 type)	IEC
Varistor (MOV1) (Optional)	Lien Shun Electronics Co., Ltd.	xxDyyyK (xx: 14, 20, 25; yyy: 471, 511, 561, 621, 681, 751, 781, 821, 911, 102, 112, 122).	300, 320, 350, 385, 420, 460, 485, 510, 550, 625, 680, 750 Vac; 40/85/56 6KV/3KA pulse test passed (coating V-0)	VDE
Varistor (MOV1) (Optional) (Alt.)	Thinking Electronic Industrial Co Ltd (Wujin Thinking Electronic Co Ltd)	TVR10yyy-D series (yyy: 471, 511, 561, 621, 681, 751, 821, 911, 102, 112)	300, 320, 350, 395, 420, 465, 510, 550, 625, 680 Vac, 40/85/56 6KV/3KA pulse test passed (coating V-0)	VDE
Varistor (MOV1) (Optional) (Alt.)	Thinking Electronic Industrial Co Ltd (Wujin Thinking Electronic Co Ltd)	TVR10yyy-V series (yyy: 471, 511, 561, 621, 681, 751, 821, 911, 102, 112)	300, 320, 350, 395, 420, 465, 510, 550, 625, 680 Vac, 40/85/56 6KV/3KA pulse test passed (coating V-0)	VDE

[서식 CP401-18-00]



기술문서 Technical Document

page: 6 / 11

안전인증번호: XU100121-16156B
(Certificate No)

접수번호: 20180509 - 0024
(Receipt No)

부품명(회로기호) Components(Part no.)	제조사(상표명) Manufacturer(Brand)	모델명(형식) Model(Type)	정격 또는 특성 (Technical Data)	인증규격 (Certification)
Varistor (MOV1) (Optional) (Alt.)	Thinking Electronic Industrial Co Ltd (Wujin Thinking Electronic Co Ltd)	TVRxxyyy-M series (xx: 14, 20; yyy: 471, 511, 561, 621, 681, 751, 821, 911, 102, 112)	300, 320, 350, 395, 420, 465, 510, 550, 625, 680 Vac, 40/125/56 6KV/3KA pulse test passed (coating V-0)	VDE
Varistor (MOV1) (Optional) (Alt.)	Thinking Electronic Industrial Co Ltd (Wujin Thinking Electronic Co Ltd)	TVRxxyyy series (xx: 14, 20; yyy: 471, 511, 561, 621, 681, 751, 821, 911, 102, 112)	300, 320, 350, 395, 420, 465, 510, 550, 625, 680 Vac, 40/85/56 6KV/3KA pulse test passed (coating V-0)	VDE
Varistor (MOV1) (Optional) (Alt.)	Joyin Co. Ltd	xxSyyyK (xx: 10, 14, 20; yyy: 471, 511, 561, 621, 681, 751, 781, 821, 911, 102, 112)	300, 320, 350, 385, 420, 460, 485, 510, 550, 625, 680 Vac; 40/85/56 6KV/3KA pulse test passed (coating V-0)	VDE
Varistor (MOV1) (Optional) (Alt.)	Joyin Co. Ltd	xxNyyyK (xx: 10, 14, 20; yyy: 471, 511, 561, 621, 681, 751, 781, 821, 911, 102, 112, 182)	300, 320, 350, 385, 420, 460, 485, 510, 550, 625, 680, 1000 Vac; 40/85/56 6KV/3KA pulse test passed (coating V-0)	VDE
Varistor (MOV1) (Optional) (Alt.)	DongGuan Littelfuse Electronics Co Ltd	CIII series / LA series VxxxLAyy series for UL (xxx:300, 320, 385, 420, 460, 480, 510, 550, 575, 625, 660, 680; yy:10, 20, 40, 50, 80, 100)	300, 320, 385, 420, 460, 480, 510, 550, 575, 625, 660, 680 Vac; 40/85/56 6KV/3KA pulse test passed (coating V-0)	VDE
Varistor (MOV1) (Optional) (Alt.)	EPCOS (ZHUHAI FTZ) CO LTD (Epcos OHG(Siemens AG))	S(NF)xxKyyy (xx: 14, 20; yyy: 300, 320, 350, 385, 420, 440, 460, 510, 550, 625, 680, 1000)	300, 320, 350, 385, 420, 440, 460, 510, 550, 625, 680, 1100 Vac, 40/85/56 6KV/3KA pulse test passed (coating V-0)	VDE
Varistor (MOV1) (Optional) (Alt.)	EPCOS (ZHUHAI FTZ) CO LTD (Epcos OHG(Siemens AG))	Q20Kyyy (yyy: 300, 320)	300, 320 Vac, 40/85/56 6KV/3KA pulse test passed (coating V-0)	VDE
Varistor (MOV1) (Optional) (Alt.)	EPCOS (ZHUHAI FTZ) CO LTD (Epcos OHG(Siemens AG))	S(NF)10KyyyE2K1 (yyy: 300, 320, 350, 385, 420, 460, 510, 550, 625, 680)	300, 320, 350, 385, 420, 440, 460, 510, 550, 625, 680 Vac, 40/85/56 6KV/3KA pulse test passed (coating V-0)	VDE
Varistor (MOV1) (Optional) (Alt.)	BRIGHTKING (SHENZHEN) CO LTD	yyyKDxx (xx: 10, 14, 20; yyy: 471, 511, 561, 621, 681, 751, 781, 821, 911, 102, 112)	300, 320, 350, 385, 420, 460, 485, 510, 550, 625, 680 Vac, 40/85/56 6KV/3KA pulse test passed (coating V-0)	VDE



기술문서 Technical Document

page: 7 / 11

안전인증번호: XU100121-16156B
(Certificate No)

접수번호: 20180509 - 0024
(Receipt No)

부품명(회로기호) Components(Part no.)	제조사(상표명) Manufacturer(Brand)	모델명(형식) Model(Type)	정격 또는 특성 (Technical Data)	인증규격 (Certification)
Optical Isolator (M12, M13, M14, M16, M202, M203)	Everlight Elertronic (China) Co., Ltd.	CNY-171 series., CNY17F1 series., EL610. ("." Can be "blank, A-Z or numbers and denote different pin shape.)	Minimum 3000 Vac, thermal cycling test passed by FIMKO, Insulation thickness =0.5mm, internal creepage=6mm, external creepage=7.7 mm; 110 °C	VDE
Optical Isolator (M12, M13, M14, M16, M202, M203) (Alt.)	Vishay semiconductor GMBH (Vishay Infrared Components Inc)	TCLT10xx series (xx can be "00-03, 06-09"), TCLT11xx series (xx can be "01-03, 06-09"), TCLT1600 series.	Minimum 4800 Vac, Thermal cycling test passed by FIMKO, external creepage=8.2 mm, 100 °C	VDE
Optical Isolator (M12, M13, M14, M16, M202, M203) (Alt.)	RENESAS ELECTRONICS CORPORATION (NEC Electronics Corp Compound Semiconductor Device Div)	PS2381-1	Minimum 5000 Vac Insulation thickness = 0.4mm, thermal cycling test passed by FIMKO, external creepage 8mm min., 115 °C	VDE
Optical Isolator (M12, M13, M14, M16, M202, M203) (Alt.)	Cosmo Electronics Corporation	KT1yxx series (y can be "0-4 and 6", xx can be "CTR Rank, 00-zz")	Minimum 4800 Vac, Insulation thickness = 0.7mm, thermal cycling test passed by FIMKO, external creepage=8.6 mm, 115 °C	VDE
Optical Isolator (M12, M13, M14, M16, M202, M203) (Alt.)	Everlight Elertronic (China) Co., Ltd.	EL817 series	Minimum 3000 Vac, thermal cycling test passed by NEMKO, Insulation thickness=0.5mm,internal creepage=6mm, external creepage=7.7 mm;110 °C	VDE
Optical Isolator (M12, M13, M14, M16, M202, M203) (Alt.)	RENESAS ELECTRONICS CORPORATION (NEC Electronics Corp Compound Semiconductor Device Div)	PS2561 series	Minimum 5000 Vac, Insulation thickness =0.4mm, thermal cycling test passed by FIMKO, external creepage=7mm, 100 °C	VDE
Optical Isolator (M12, M13, M14, M16, M202, M203) (Alt.)	Cosmo Electronics Corporation	K1010 series	Minimum 5000 Vac Insulation thickness =0.5mm, thermal cycling tested by FIMKO , external creepage=6.5 mm, 115 °C	VDE



기술문서 Technical Document

page: 8 / 11

안전인증번호: XU100121-16156B
(Certificate No)

접수번호: 20180509 - 0024
(Receipt No)

부품명(회로기호) Components(Part no.)	제조사(상표명) Manufacturer(Brand)	모델명(형식) Model(Type)	정격 또는 특성 (Technical Data)	인증규격 (Certification)
Optical Isolator (M12, M13, M14, M16, M202, M203) (Alt.)	Vishay Semiconductor GMBH (Vishay Infrared Components Inc)	VOL617 series/ VOL618A series	Minimum 5000 Vac Insulation thickness=0.4mm,thermal cycling tested by FIMKO, external creepage=8.0 mm, 110 ℃	VDE
Optical Isolator (M12, M13, M14, M16, M202, M203) (Alt.)	Lite-on Technology Co. (Lite-on Electronic, Inc.)	LTV-817	Minimum 5000 Vac Insulation thickness =0.8mm, thermal cycling test pass, external creepage=7.8 mm, 100 ℃	VDE
Optical Isolator (M12, M13, M14, M16, M202, M203) (Alt.)	EVERLIGHT ELECTRONICS CO LTD	EL101 series	Minimum 3000 Vac, thermal cycling test passed by NEMKO, Insulation thickness =0.4mm, external creepage=8.1 mm; 110 ℃	VDE
Optical Isolator (M12, M13, M14, M16, M202, M203) (Alt.)	LITE-ON TECHNOLOGY CORP	LTV-100x(x can be 0~9)	Minimum 5000 Vac Insulation thickness =0.4mm, thermal cycling tested by FIMKO, external creepage=8.3 mm,100 ℃	VDE
Optical Isolator (M6, M8)	SILICON LABORATORIES	Si8233BD-D	Minimum 5000 Vac Insulation thickness =0.4mm, thermal cycling tested by VDE, external creepage=8.6 mm, 125 ℃	VDE
Relay (REL1) (optional)	Song Chuan Precision Co Ltd	307HN-1AH-F-C	250 Vac, 10A for VDE	-
Relay (REL1) (optional) (Alt.)	HONGFA	HF32F series	250 Vac, 10A	-
Relay (REL1) (optional) (Alt.)	DONGGUAN GOLDEN	GI-1A-12LHF, GI series	250 Vac, 10A	-
Choke (L1)	AcBel Polytech Inc.(API)	21Q84	130 ℃ min.	-
Choke (L4)	AcBel Polytech Inc.(API)	21O11	130 ℃ min.	-
Choke (L5)	AcBel Polytech Inc.(API)	21Q79	130 ℃ min.	-
Choke (L403)	Various	Various	130 ℃	-
Transformer (T5)	AcBel Polytech Inc.(API)	25P07	Class B	-
Triple Insulated Wire	Totoku Electric Co Ltd	TIW-2	(For T5), Electric strength: 4000 Vrms, 130 ℃	UL

[서식 CP401-18-00]



기술문서 Technical Document

page: 9 / 11

안전인증번호: XU100121-16156B
(Certificate No)

접수번호: 20180509 - 0024
(Receipt No)

부품명(회로기호) Components(Part no.)	제조사(상표명) Manufacturer(Brand)	모델명(형식) Model(Type)	정격 또는 특성 (Technical Data)	인증규격 (Certification)
Triple Insulated Wire (Alt.)	Totoku Electric Co Ltd	TIW-3	(For T5), Electric strength: 4000 Vrms, 155 °C	UL
Triple Insulated Wire (Alt.)	Furukawa Electric Co Ltd	TEX-E	(For T5), Electric strength: 3000 Vrms, 130 °C	UL
Transformer (T201)	AcBel Polytech Inc.(API)	25P05	Class B	-
Triple Insulated Wire	Cosmolink Co Ltd	TIW-M	(For T201), Electric strength: 3000 Vrms, 130 °C	UL
Transformer (T401)	AcBel Polytech Inc.(API)	25P06	Class B	-
Transformer (T401) (Alt.)	AcBel Polytech Inc.(API)	25P59	Class B	-
Triple Insulated Wire	Cosmolink Co Ltd	TIW-2	(For T401), Electric strength: 4000 Vrms, 130 °C	UL
Triple Insulated Wire (Alt.)	TA YA CO.	TILW-B	(For T401), Electric strength: 3000 Vrms, 130 °C	UL
DC Fan	ASIA VITAL COMPONENTS CO LTD	DBTD0428B2G(V) where (V) may be xxxx, where x may be A through Z, 0 through 9, "-", or blank.	12 V, 1.5 A, 31.16 CFM	-
DC Fan (Alt.)	Foxconn Technology Co., Ltd.	PIA040H12Q	12 V, 1.7 A, 30.64 CFM	-
DC Fan (Alt.)	NIDEC AMERICA CORP	(a)40S12BGD5-07T where (a) may be b, c, h, i, l, r~w.	12 V, 1 A, 27.8 CFM	-
DC Fan (Alt.)	NMB Technologies Corporation/MINEE CO LTD	04028DA-12S-(d)(e) where(d) may be "A", "B", "C", "E", "F", "G", "S", "T", "U", "W", "Y", or "Z"; (e) may be "A", "B", "L", "M", "T", "U", "E", "F", "G", "H", "J", "K", "C", "D", "N", "P", "V", "W" or 1-6	12 V, 1.4 A, 27.6 CFM	-
PCB1	Interchangeable	Interchangeable	V-0, 140 °C max.	UL
PCB	Interchangeable	Interchangeable	V-1 min., 105 °C min.	UL

[서식 CP401-18-00]



기술 문서 Technical Document

page: 10 / 11

안전인증번호: XU100121-16156B
(Certificate No)

접수번호: 20180509 - 0024
(Receipt No)

부품명(회로기호) Components(Part no.)	제조사(상표명) Manufacturer(Brand)	모델명(형식) Model(Type)	정격 또는 특성 (Technical Data)	인증규격 (Certification)
Thermistor (RT1) (optional)	Interchangeable	Interchangeable	25 Ω at 25 °C, 4A; 80 Ω at 25 °C , 2A; 80 Ω at 25 °C , 6A.	-
Thermistor (TR301)	Interchangeable	Interchangeable	10 kΩ at 25 °C , NTC	-
Bridge Diode (BD1)	Interchangeable	Interchangeable	600 V min., 25 A min.	-



기술문서 Technical Document

page: 11 / 11

안전인증번호: XU100121-16156B
(Certificate No)

접수번호: 20180509 - 0024
(Receipt No)

3. 전기용품안전인증의 변경현황(Status of Certificate Revisions)

일자(Date)	발급현황(Status of issues)
	변경내용(Modification of Contents)
2016/08/03	안전확인(기본+파생)
2018/05/18	안전확인(부품)

4. 기타(Carefully Informed Note)

- 1) 안전관리부품 및 재질목록에 기재된 사항은 안전에 직접적인 영향을 주는 부분이므로 내용을 변경 또는 복수등재를 원하는 경우 안전인증변경신청 또는 안전확인변경신고를 하여야 합니다. 안전인증변경신청 또는 안전확인변경신고를 하지 않고 임의로 변경하는 경우에는 전기용품 및 생활용품 안전관리법에 따라 행정조치 될 수 있습니다.

The certificate holder should apply for a revision of the certificate if the registered critical components are to be changed, modified or alternated. Should the contents of Certificate are altered without the application for the modification, the administrative measures can occur according to the Electrical Appliances and Consumer Products Safety Control Act.

- 2) 공장주소(전화번호포함), 대표자, 상호 및 부품변경, 신고인정보 등 안전인증 또는 안전확인신고의 내용이 변경되었을 때, 안전인증변경신청 또는 안전확인변경신고를 하지 않을 경우에는 전기용품 및 생활용품 안전관리법에 따라 행정조치 될 수 있습니다.

Should a factory address, president name, manufacturer name and critical component are altered without the application for the modification, the administrative measures can occur according to the Electrical Appliances and Customer Products Safety Control Act.

- 3) 조건부 인증사항 (Conditional certification items):



FCC Test Report

Project No. : 1510T059H
Equipment : Switching Power Supply
Model Name : FSE052, R1CA2801A, FSF037, R1CA2801B,
FSF059, R1CA2551B, FSF065, R1CA2551C
Applicant : Acbel Polytech Inc.
Address : No.159, Sec. 3, Danjin Rd., Tamsui Dist., New Taipei
City 251, Taiwan

Date of Receipt : Jan. 07, 2016
Date of Test : Jan. 07, 2016 ~ Jan. 15, 2016
Issued Date : Jul. 31, 2018
Tested by : BTL Inc.

Testing Engineer :
(Pike Lee)
Technical Manager :
(James Chiu)
Authorized Signatory :
(Andy Chiu)

B T L I N C .

No.18, Ln. 171, Sec. 2, Jiuzong Rd.,
Neihu Dist., Taipei City 114, Taiwan (R.O.C.)
TEL: +886-2-2657-3299 FAX: +886-2-2657-3331



Declaration

BTL represents to the client that testing is done in accordance with standard procedures as applicable and that test instruments used has been calibrated with standards traceable to international standard(s) and/or national standard(s).

BTL's reports apply only to the specific samples tested under conditions. It is manufacture's responsibility to ensure that additional production units of this model are manufactured with the identical electrical and mechanical components. **BTL** shall have no liability for any declarations, inferences or generalizations drawn by the client or others from **BTL** issued reports.

The report must not be used by the client to claim product certification, approval, or endorsement by NVLAP, NIST, or any agency of the U.S. Government.

This report is the confidential property of the client. As a mutual protection to the clients, the public and ourselves, the test report shall not be reproduced, except in full, without our written approval.

BTL's laboratory quality assurance procedures are in compliance with the **ISO Guide 17025** requirements, and accredited by the conformity assessment authorities listed in this test report.

BTL is not responsible for the sampling stage, so the results only apply to the sample as received.

The information, data and test plan are provided by manufacturer, so it is manufacturer's responsibility to ensure that the apparatus meets the essential requirements in all the possible configurations as representative of its intended use.

Limitation

For the use of the authority's logo is limited unless the Test Standard(s)/Scope(s)/Item(s) mentioned in this test report is (are) included in the conformity assessment authorities acceptance respective.

Table of Contents	Page
REPORT ISSUED HISTORY	4
1 . VERIFICATION	5
2 . SUMMARY OF TEST RESULTS	6
2.1 TEST FACILITY	7
2.2 MEASUREMENT UNCERTAINTY	7
3 . GENERAL INFORMATION	8
3.1 GENERAL DESCRIPTION OF EUT	8
3.2 DESCRIPTION OF TEST MODES	9
3.3 BLOCK DIAGRAM SHOWING THE CONFIGURATION OF SYSTEM TESTED	10
3.4 DESCRIPTION OF SUPPORT UNITS	10
4 . EMC EMISSION TEST	11
4.1 CONDUCTED EMISSION TEST	11
4.1.1 LIMITS	11
4.1.2 MEASUREMENT INSTRUMENTS LIST	11
4.1.3 TEST PROCEDURE	12
4.1.4 DEVIATION FROM TEST STANDARD	12
4.1.5 TEST SETUP	12
4.1.6 EUT OPERATING CONDITIONS	12
4.1.7 TEST RESULTS	13
4.2 RADIATED EMISSION TEST	15
4.2.1 LIMITS	15
4.2.2 MEASUREMENT INSTRUMENTS LIST	16
4.2.3 TEST PROCEDURE	17
4.2.4 DEVIATION FROM TEST STANDARD	17
4.2.5 TEST SETUP	17
4.2.6 EUT OPERATING CONDITIONS	17
4.2.7 TEST RESULTS-BELOW 1 GHZ	18
5 . EUT TEST PHOTO	20

REPORT ISSUED HISTORY

Issue No.	Description	Issued Date
BTL-FCCE-1-1510059	Original report.	Oct. 16, 2015
BTL-FCCE-1-1510059A	Compared with previous report (BTL-FCCE-1-1510059), the model FSF059, R1CA2551B, FSF065 and R1CA2551C are added, all tests have been re-evaluated and recorded in the test report. In this test report only records the test results of the added model, the original models' test results please refer to original report.	Jan. 18, 2016
BTL-FCCE-1-1510059B	Compared with previous report (BTL-FCCE-1-1510059A), a brand name is added only, all rest are kept as same.	Apr. 29, 2016
BTL-FCCE-1-1510T059H	Compared with the previous report (BTL-FCCE-1-1510059B), Added Input specification (100-127V~, 50/60Hz, 10.0A; 200-240V~, 50/60Hz, 5.0A or 240VDC, 5A MAX. or 100-240V~, 50/60Hz, 10.0-5.0A) for Model (FSE052, R1CA2801A, FSF037, R1CA2801B), the rest are kept the same.	Jul. 31, 2018

1. VERIFICATION

Equipment : Switching Power Supply
BrandName : AcBel
ModelName : FSE052,R1CA2801A,FSF037,R1CA2801B,FSF059,R1CA2551B,FSF065,
R1CA2551C
Applicant : AcbelPolytechInc.
Manufacturer: AcbelPolytechInc.
Address : No.159,Sec.3,DanjinRd.,TamsuiDist.,NewTaipeiCity251,Taiwan
Factory : 1) AcbelPolytechInc
2) Acbel Electronic (Dong Guan) Co., Ltd.
3) AcTel Electronic (Dong Guan) Co., Ltd.
4) Acbel Polytech (Philippines) Inc.
5) ACBEL ELECTRONIC (WUHAN) CO., LTD
Address : 1) No.159, Sec. 3, Danjin Rd., Tamsui Dist., New Taipei City 251, Taiwan
2) No. 17-28, Horng Yeh Road, Horng Yeh Ind. District, Tang Xia Town,
Dongguan, Guangdong 523710, P.R. China
3) No. 13-16, Hong Yeh 11 Rd., Hong Yeh Industrial District, Tang Xia Town,
DongGuan City, Guang Dong, P.R. China
4) No. 2 Tagaytay Ridge Drive, Carmelray Industrial Park II, Km. 54 National
Highway, Calamba City, Laguna 4027, Philippines
5) No.1, DuTai North Road, Economic Development Zone, XianTao City,
HuBei Province, People's Republic Of China
Date of Test : Jan. 07, 2016 ~ Jan. 15, 2016
Test Sample : Engineering Sample
Standard(s) : FCC Part 15, Subpart B Class A
ICES-003 Issue 5: 2012+Update:2014 Class A
CAN/CSA-CISPR 22-10 Class A
CISPR 22: 2008 Class A
ANSI C63.4-2014

The above equipment has been tested and found compliance with the requirement of the relative standards by BTL Inc.

The test data, data evaluation, and equipment configuration contained in our test report (Ref No. BTL-FCCE-1-1510T059H) were obtained utilizing the test procedures, test instruments, test sites that has been accredited by the Authority of TAF according to the ISO-17025 quality assessment standard and technical standard(s).

2. SUMMARY OF TEST RESULTS

Test procedures according to the technical standards:

Emission				
Standard(s)	Test Item	Limit	Judgment	Remark
FCC Part 15, Subpart B ICES-003 Issue 5: 2012+Update:2014 CAN/CSA-CISPR 22-10 CISPR 22: 2008	Conducted emission	Class A	PASS	-----
	Radiated emission Below 1 GHz	Class A	PASS	-----
	Radiated emission Above 1 GHz	Class A	N/A	NOTE (1) NOTE (2)

NOTE:

- (1) "N/A" denotes test is not applicable to this device.
- (2) The EUT's max operating frequency is 65 kHz which does not exceed 108 MHz, so the test will not be performed.

2.1 TEST FACILITY

The test facilities used to collect the test data in this report:

Conducted emission Test:

C05: (VCCI RN: C-4742; FCC RN:965108; FCC DN:TW1082)
No. 68-1, Ln. 169, Sec.2, Datong Rd., Xizhi Dist., New Taipei City 221, Taiwan

Radiated emission Test (Below 1 GHz):

CB08: (VCCI RN: R-4259; FCC RN:965108; FCC DN:TW1082; IC Assigned Code:20088)
No. 68-1, Ln. 169, Sec.2, Datong Rd., Xizhi Dist., New Taipei City 221, Taiwan

2.2 MEASUREMENT UNCERTAINTY

The reported uncertainty of measurement $y \pm U$, where expanded uncertainty U is based on a standard uncertainty multiplied by a coverage factor of $k=2$, providing a level of confidence of approximately **95%**.

The measurement instrumentation uncertainty considerations contained in CISPR 16-4-2. The BTL measurement uncertainty is less than the CISPR 16-4-2 U_{CISPR} requirement.

A. Conducted emission test:

Test Site	Method	Measurement Frequency Range	U, (dB)
C05	CISPR	150 kHz~30MHz	2.04

B. Radiated emission test:

Test Site	Method	Measurement Frequency Range	Ant. H / V	U, (dB)
CB08 (10m)	CISPR	30 MHz ~ 200 MHz	V	4.04
		30 MHz ~ 200 MHz	H	4.04
		200 MHz ~ 1, 000 MHz	V	4.08
		200 MHz ~ 1, 000 MHz	H	4.02

Our calculated Measurement Instrumentation Uncertainty is shown in the tables above.

These are our U_{lab} values in CISPR 16-4-2 terminology.

Since Table 1 of CISPR 16-4-2 has values of measurement instrumentation uncertainty, called U_{CISPR} , as follows:

Conducted Disturbance (mains port) – 150 kHz – 30 MHz : 3.6 dB

Radiated Disturbance (electric field strength on an open area test site or alternative test site) – 30 MHz – 1000 MHz : 5.2 dB

It can be seen that our U_{lab} values are smaller than U_{CISPR} .

Note: Unless specifically mentioned, the uncertainty of measurement has not been taken into account to declare the compliance or non-compliance to the specification.

3. GENERAL INFORMATION

3.1 GENERAL DESCRIPTION OF EUT

Equipment	Switching Power Supply		
Model Name	FSE052, R1CA2801A, FSF037, R1CA2801B, FSF059, R1CA2551B, FSF065, R1CA2551C		
Brand Name	AcBel		
OEM Brand/Model Name	N/A.		
Model Difference	Only differ in model name and fan direction.		
	Model	Fan Direction	Power Rating
	FSE052, R1CA2801A, FSF059, R1CA2551B	IN	Please refer to Power Rating
	FSF037, R1CA2801B, FSF065, R1CA2551C	OUT	Please refer to Power Rating
Power Source	AC Mains.		
Power Rating	<p>Model (FSE052, R1CA2801A, FSF037, R1CA2801B): I/P: AC100-127V~, 50/60Hz, 10.0A; 200-240V~, 50/60Hz, 5.0A or 240VDC, 5A MAX. or 100-240V~, 50/60Hz, 10.0-5.0A O/P: DC +12.0V/66.7A, +12Vsb/3.0A TOTAL POWER 800W MAX.</p> <p>Model (FSF059, R1CA2551B, FSF065, R1CA2551C): I/P: AC 100-127V~, 50/60Hz, 7.0A; 200-240V~, 50/60Hz, 3.5A or 240VDC, 3.5A MAX. O/P: DC +12.0V/45.8A, +12Vsb/3.0A TOTAL POWER 550W MAX.</p>		
Products Covered	N/A		

Note:

1. For a more detailed features description, please refer to the manufacturer's specifications or the user's manual.

3.2 DESCRIPTION OF TEST MODES

To investigate the maximum EMI emission characteristics generates from EUT, the test system was pre-scanning tested base on the consideration of following EUT operation mode or test configuration mode which possible have effect on EMI emission level. Each of these EUT operation mode(s) or test configuration mode(s) mentioned above was evaluated respectively.

Pretest Mode	Description
Mode 1	FULL LOAD (AC in)
Mode 2	FULL LOAD (DC in)

Conducted emission test	
Final Test Mode	Description
Mode 1	FULL LOAD (AC in)

Radiated emission test	
Final Test Mode	Description
Mode 1	FULL LOAD (AC in)

3.3 BLOCK DIAGRAM SHOWING THE CONFIGURATION OF SYSTEM TESTED

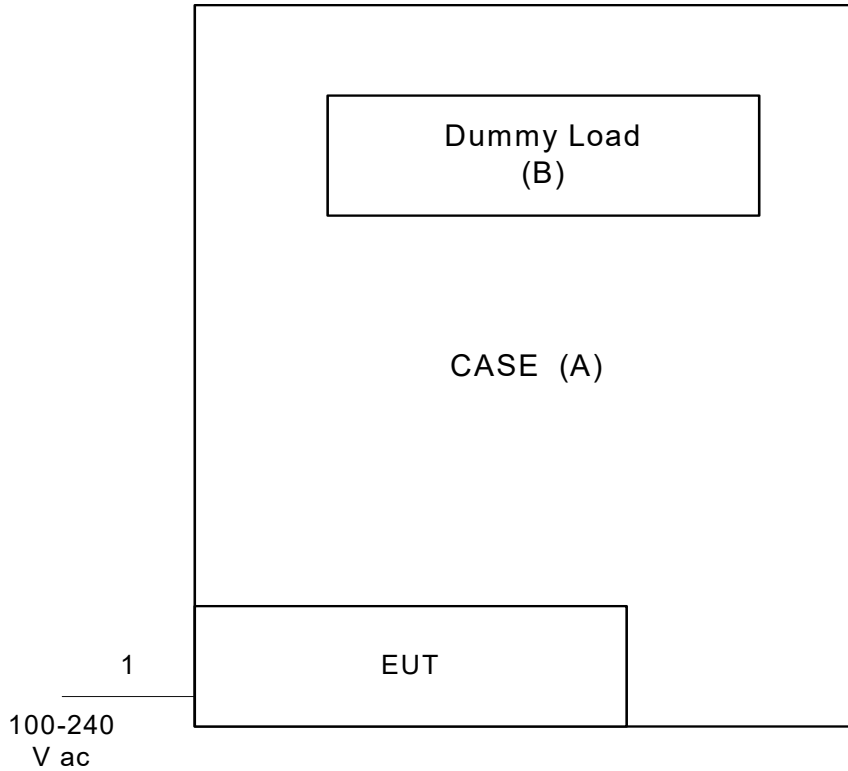

3.4 DESCRIPTION OF SUPPORT UNITS

The EUT has been tested as an independent unit together with other necessary accessories or support units. The following support units or accessories were used to form a representative test configuration during the tests.

Item	Equipment	Brand	Model/Type No.	FCC ID	Series No.
A	CASE	N/A	N/A	N/A	N/A
B	Dummy Load	N/A	N/A	N/A	N/A

Item	Shielded Type	Ferrite Core	Length	Note
1	NO	NO	1.7m	Power Cable

Note:

- (1) The support equipment was authorized by Declaration of Conformity (DOC).

4. EMC EMISSION TEST

4.1 CONDUCTED EMISSION TEST

4.1.1 LIMITS (FREQUENCY RANGE 150 KHZ-30MHZ)

FREQUENCY (MHz)	Class A (dBuV)		Class B (dBuV)	
	Quasi-peak	Average	Quasi-peak	Average
0.15 - 0.5	79.00	66.00	66 - 56 *	56 - 46 *
0.50 - 5.0	73.00	60.00	56.00	46.00
5.0 - 30.0	73.00	60.00	60.00	50.00

NOTE:

- (1) The tighter limit applies at the band edges.
- (2) The limit of " * " marked band means the limitation decreases linearly with the logarithm of the frequency in the range.
- (3) The test result calculated as following:
 Measurement Value = Reading Level + Correct Factor
 Correct Factor = Insertion Loss + Cable Loss + Attenuator Factor(if use)
 Margin Level = Measurement Value – Limit Value

4.1.2 MEASUREMENT INSTRUMENTS LIST

Item	Kind of Equipment	Manufacturer	Type No.	Serial No.	Calibrated until
1	TWO-LINE V-NETWORK	R&S	ENV216	101050	Feb. 01, 2016
2	Test Cable	TIMES	CFD300-NL	C05	Jun. 14, 2016
3	EMI Test Receiver	R&S	ESR3	101854	Dec. 10, 2016
4	Measurement Software	EZ	EZ_EMCC (Version NB-03A)	N/A	N/A

Remark: "N/A" denotes no model name, no serial no. or no calibration specified.
 All calibration period of equipment list is one year.

4.1.3 TEST PROCEDURE

- a. The EUT was placed 0.8 meters from the horizontal ground plane with EUT being connected to the power mains through a line impedance stabilization network (LISN). All other support equipments powered from additional LISN(s). The LISN provide 50 Ohm/ 50uH of coupling impedance for the measuring instrument.
- b. Interconnecting cables that hang closer than 40 cm to the ground plane shall be folded back and forth in the center forming a bundle 30 to 40 cm long.
- c. I/O cables that are not connected to a peripheral shall be bundled in the center. The end of the cable may be terminated, if required, using the correct terminating impedance. The overall length shall not exceed 1 m.
- d. LISN at least 80 cm from nearest part of EUT chassis.
- e. For the actual test configuration, please refer to the related Item –EUT Test Photos.

NOTE:

- a. Reading in which marked as Peak, QP or AVG means measurements by using are Quasi-Peak or Average Mode with Detector BW=9 kHz (6 dB Bandwidth).
- b. All readings are Peak Mode value unless otherwise stated QP or AVG in column of Note. If the Peak or QP Mode Measured value compliance with the QP Limits and lower than AVG Limits, the EUT shall be deemed to meet both QP & AVG Limits and then only Peak or QP Mode was measured, but AVG Mode didn't perform.

4.1.4 DEVIATION FROM TEST STANDARD

No deviation

4.1.5 TEST SETUP

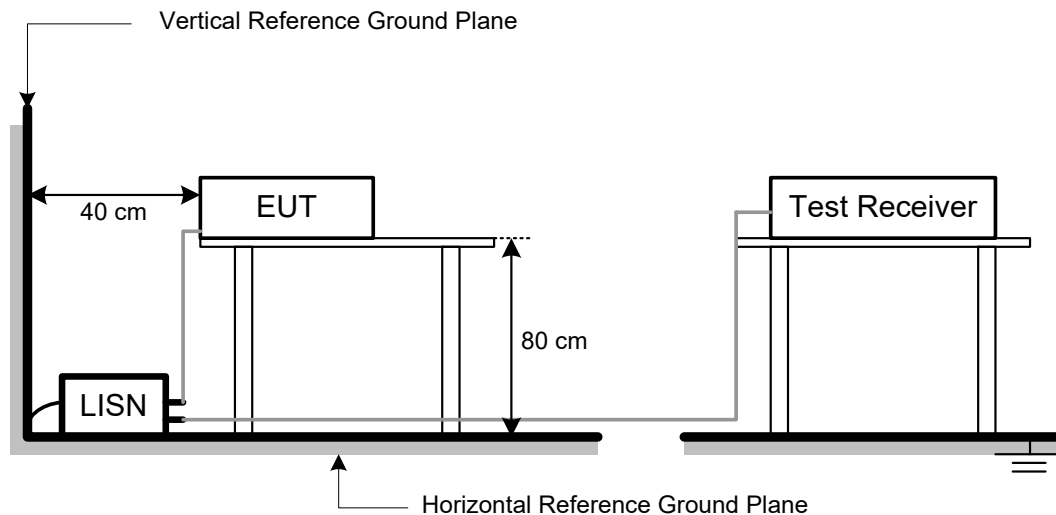

4.1.6 EUT OPERATING CONDITIONS

The EUT exercise program used during radiated and/or conducted emission measurement was designed to exercise the various system components in a manner similar to a typical use.

4.1.7 TEST RESULTS

E.U.T	Switching Power Supply	Model Name	FSF059
Temperature	24 °C	Relative Humidity	50%
Test Voltage	AC 120V/60Hz		
Test Mode	FULL LOAD (AC in)		

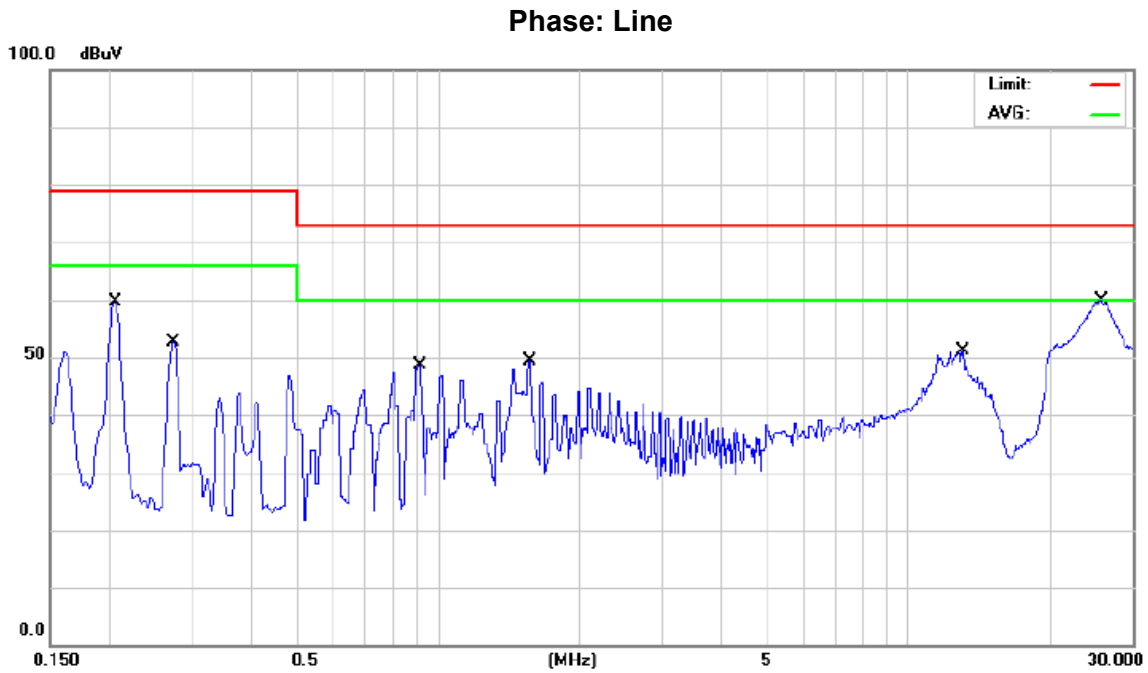

No. Mk.	Freq. MHz	Reading Level dBuV	Correct Factor dB	Measurement dBuV	Limit dBuV	Margin dB	Detector	Comment
1	0.2053	48.20	9.66	57.86	79.00	-21.14	QP	
2	0.2053	44.60	9.66	54.26	66.00	-11.74	AVG	
3	0.2739	41.40	9.66	51.06	79.00	-27.94	QP	
4	0.2739	35.90	9.66	45.56	66.00	-20.44	AVG	
5	0.9140	37.50	9.70	47.20	73.00	-25.80	QP	
6	0.9140	36.20	9.70	45.90	60.00	-14.10	AVG	
7	1.5620	36.90	9.74	46.64	73.00	-26.36	QP	
8	1.5620	35.20	9.74	44.94	60.00	-15.06	AVG	
9	13.0500	34.10	9.89	43.99	73.00	-29.01	QP	
10	13.0500	29.00	9.89	38.89	60.00	-21.11	AVG	
11	25.6000	45.20	9.92	55.12	73.00	-17.88	QP	
12 *	25.6000	41.00	9.92	50.92	60.00	-9.08	AVG	

E.U.T	Switching Power Supply	Model Name	FSF059
Temperature	24 °C	Relative Humidity	50%
Test Voltage	AC 120V/60Hz		
Test Mode	FULL LOAD (AC in)		

Phase: Neutral

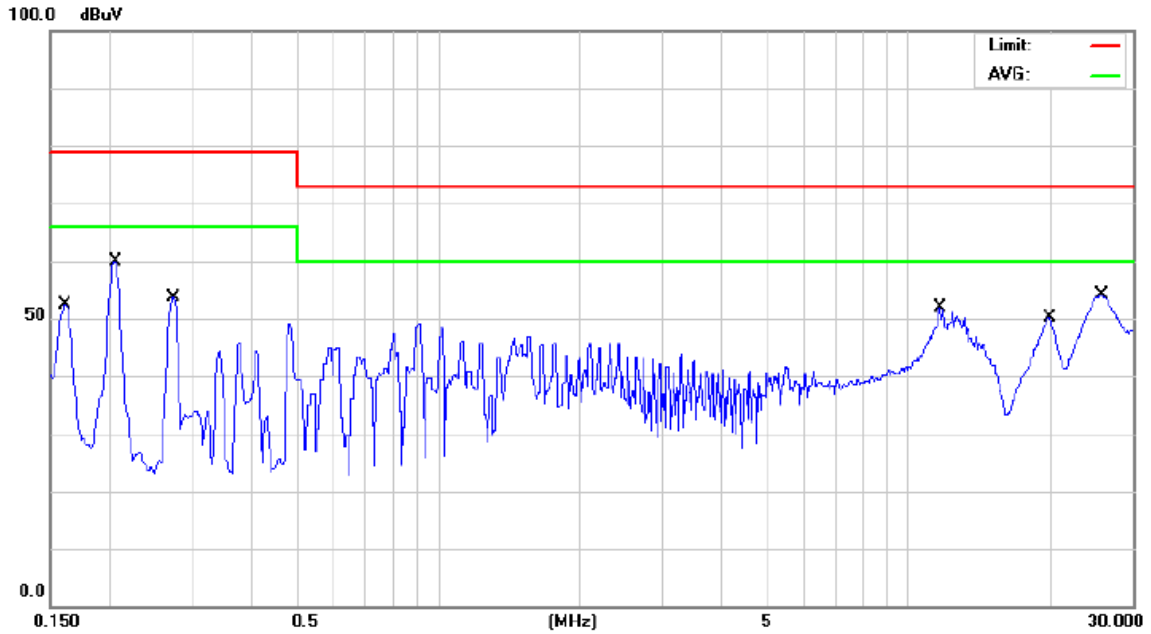

No.	Mk.	Freq. MHz	Reading Level dBuV	Correct Factor dB	Measure- ment dBuV	Limit dBuV	Margin dB	Detector	Comment
1		0.1612	41.80	9.66	51.46	79.00	-27.54	QP	
2		0.1612	40.90	9.66	50.56	66.00	-15.44	AVG	
3		0.2053	48.20	9.66	57.86	79.00	-21.14	QP	
4	*	0.2053	44.70	9.66	54.36	66.00	-11.64	AVG	
5		0.2732	42.10	9.66	51.76	79.00	-27.24	QP	
6		0.2732	36.40	9.66	46.06	66.00	-19.94	AVG	
7		11.6500	36.90	9.92	46.82	73.00	-26.18	QP	
8		11.6500	30.50	9.92	40.42	60.00	-19.58	AVG	
9		19.8500	34.20	9.90	44.10	73.00	-28.90	QP	
10		19.8500	29.60	9.90	39.50	60.00	-20.50	AVG	
11		25.7000	37.70	9.95	47.65	73.00	-25.35	QP	
12		25.7000	32.50	9.95	42.45	60.00	-17.55	AVG	

4.2 RADIATED EMISSION TEST

4.2.1 LIMITS

Below 1 GHz

Measurement Method and Applied Limits:

ANSI C63.4:

Frequency (MHz)	Class A (at 10m)		Class B (at 3m)	
	(uV/m) Field strength	(dBuV/m) Field strength	(uV/m) Field strength	(dBuV/m) Field strength
30 - 88	90	39	100	40
88 - 216	150	43.5	150	43.5
216 - 960	210	46.4	200	46
Above 960	300	49.5	500	54

CISPR 22 or CAN/CSA-CISPR 22-10:

Frequency (MHz)	Class A (at 10m)	Class B (at 10m)
	dBuV/m	dBuV/m
30 - 230	40	30
230 - 1000	47	37

NOTE:

- (1) The limit for radiated test was performed according to as following:
FCC Part 15, Subpart B, ICES-003 Issue 5: 2012+Update:2014
- (2) The tighter limit applies at the band edges.
- (3) Emission level (dBuV/m) = 20log Emission level (uV/m).
3m Emission level = 10m Emission level + 20log(10m/3m).
- (4) The test result calculated as following:
Measurement Value = Reading Level + Correct Factor
Correct Factor = Antenna Factor + Cable Loss - Amplifier Gain(if use)
Margin Level = Measurement Value - Limit Value

4.2.2 MEASUREMENT INSTRUMENTS LIST

Below 1 GHz:

Item	Kind of Equipment	Manufacturer	Type No.	Serial No.	Calibrated until
1	Log-Bicon Antenna	Schwarzbeck	VULB 9168	9168-641	Sep. 10, 2016
2	Log-Bicon Antenna	Schwarzbeck	VULB 9168	9168-642	Sep. 10, 2016
3	Pre-Amplifier	EMCI	EMC9135	980281	Oct. 05, 2016
4	Pre-Amplifier	EMCI	EMC9135	980282	Oct. 05, 2016
5	Test Cable	EMCI	EMC8D-NM-NM-80 0	150102	Jan. 23, 2016
6	Test Cable	EMCI	EMC8D-NM-NM-80 0	150103	Jan. 23, 2016
7	Test Cable	EMCI	EMC8D-NM-NM-50 00	150105	Jan. 23, 2016
8	Test Cable	EMCI	EMC8D-NM-NM-50 00	150106	Jan. 23, 2016
9	Test Cable	EMCI	EMC8D-NM-NM-10 000	150107	Jan. 23, 2016
10	Test Cable	EMCI	EMC8D-NM-NM-20 000	150116	Jan. 23, 2016
11	EXA Spectrum Analyzer	Keysight Technologies	N9010A	MY54200483	Sep. 21, 2016
12	EMI Receiver	Keysight Technologies	N9038A	MY54130009	Oct. 02, 2016
13	Measurement Software	EZ	EZ EMC (Version NB-03A)	N/A	N/A
14	Attenuator	Inmet	AT-N0507	01	Sep. 10, 2016
15	Attenuator	Inmet	AT-N0508	02	Sep. 10, 2016

Remark: "N/A" denotes no model name, no serial no. or no calibration specified.

All calibration period of equipment list is one year.

4.2.3 TEST PROCEDURE

- The measuring distance of 10 m shall be used for measurements. The EUT was placed on the top of a rotating table 0.8 meter above the ground at a 10 meter semi-anechoic chamber. The table was rotated 360 degrees to determine the position of the highest radiation.(below 1GHz)
- The height of the equipment or of the substitution antenna shall be 0.8 m, the height of the test antenna shall vary between 1 m to 4 m. Both horizontal and vertical polarizations of the antenna are set to make the measurement.
- The initial step in collecting radiated emission data is a receiver peak detector mode pre-scanning the measurement frequency range. Significant peaks are then marked and then Quasi Peak detector mode re-measured.
- All readings are Peak unless otherwise stated QP in column of Note. Peak denotes that the Peak reading compliance with the QP Limits and then QP Mode measurement didn't perform. (below 1GHz)
- For the actual test configuration, please refer to the related Item - Block Diagram of system tested (please refer to 3.3).

4.2.4 DEVIATION FROM TEST STANDARD

No deviation

4.2.5 TEST SETUP

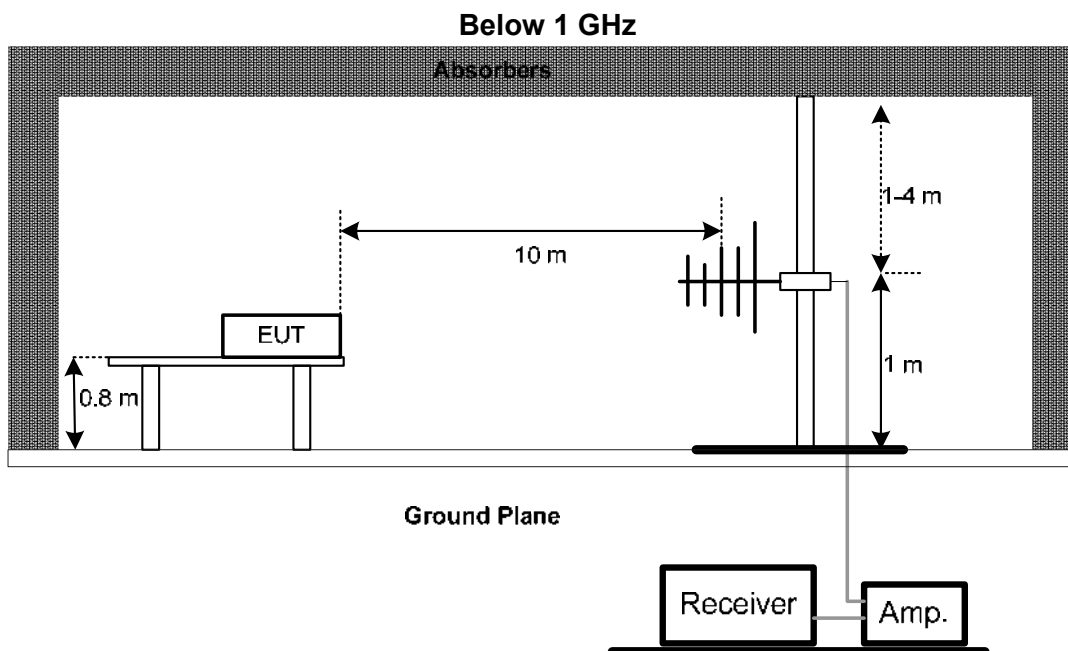

4.2.6 EUT OPERATING CONDITIONS

The EUT tested system was configured as the statements of 4.1.6 unless otherwise a special operating condition is specified in the follows during the testing.

4.2.7 TEST RESULTS-BELOW 1 GHZ

E.U.T	Switching Power Supply	Model Name	FSF059
Temperature	24°C	Relative Humidity	67%
Test Voltage	AC 120V/60Hz		
Test Mode	FULL LOAD (AC in)		

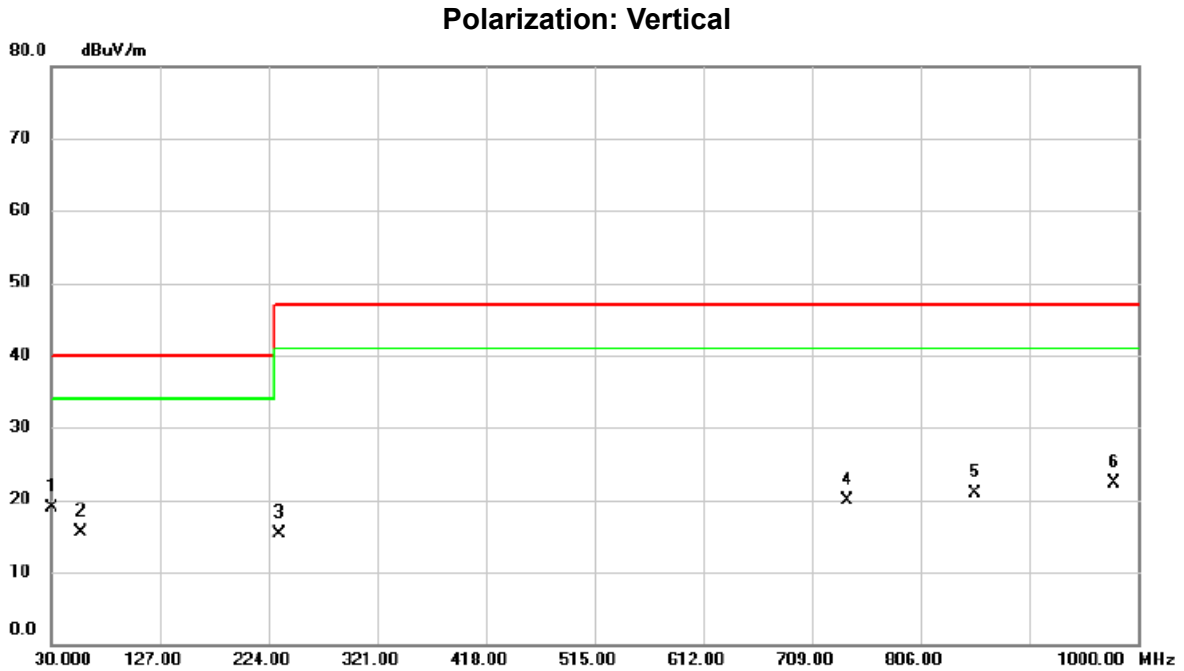

No.	Mk.	Freq. MHz	Reading Level dBuV	Correct Factor dB	Measure- ment dBuV/m	Limit dBuV/m	Margin dB	Detector	Antenna Height cm	Table Degree	Comment
1	*	30.0000	38.41	-19.54	18.87	40.00	-21.13	QP	100	360	
2		56.6750	33.75	-18.15	15.60	40.00	-24.40	QP	200	146	
3		233.7000	34.85	-19.62	15.23	47.00	-31.77	QP	100	120	
4		740.5250	28.33	-8.35	19.98	47.00	-27.02	QP	299	360	
5		854.5000	28.51	-7.67	20.84	47.00	-26.16	QP	400	0	
6		978.1750	28.43	-6.17	22.26	47.00	-24.74	QP	400	155	

E.U.T	Switching Power Supply	Model Name	FSF059
Temperature	24°C	Relative Humidity	67%
Test Voltage	AC 120V/60Hz		
Test Mode	FULL LOAD (AC in)		

Polarization: Horizontal

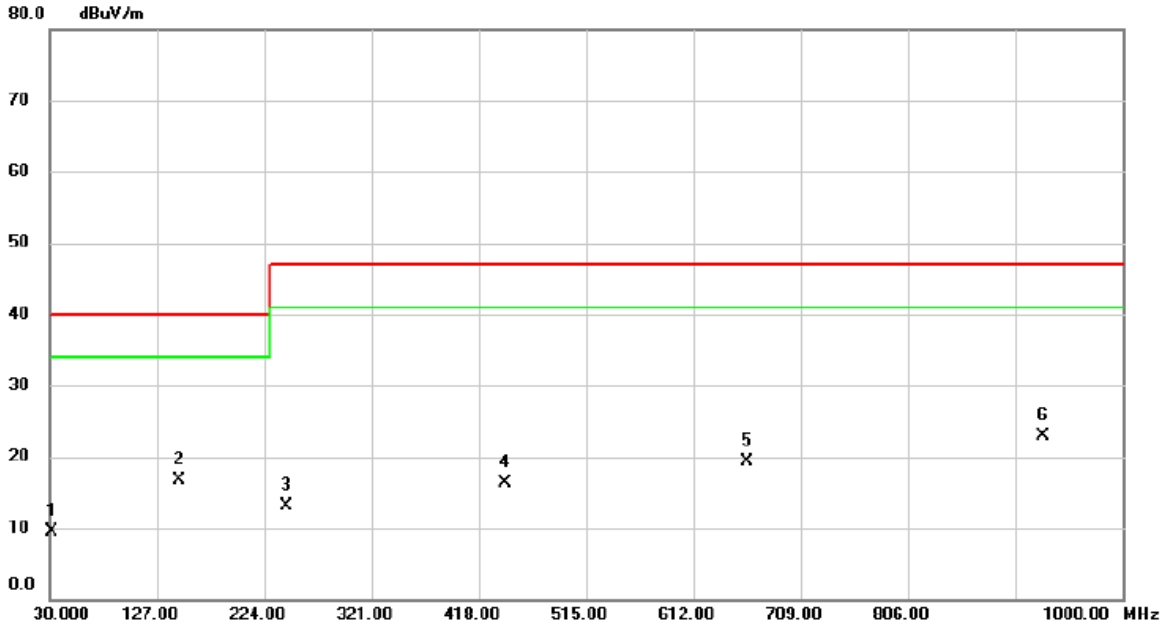

No.	Mk.	Freq. MHz	Reading Level dBuV	Correct Factor dB	Measure- ment dBuV/m	Limit dBuV/m	Margin dB	Antenna Height cm	Table Degree	Comment
1		31.9400	28.22	-18.77	9.45	40.00	-30.55	199	268	
2	*	147.3700	33.39	-16.61	16.78	40.00	-23.22	399	97	
3		243.4000	31.09	-17.98	13.11	47.00	-33.89	199	284	
4		441.2800	27.05	-10.83	16.22	47.00	-30.78	100	201	
5		660.5000	27.63	-8.34	19.29	47.00	-27.71	100	147	
6		928.2200	27.77	-4.80	22.97	47.00	-24.03	399	189	

5. EUT TEST PHOTO

Conducted emission test photos



Radiated emission below 1 GHz test photos

