

抽換

抽換原因: 導入UKCA & silicon lab替代料.20211001



康舒科技

ACBEL POLYTECH INC.

Approval Sheet

Model No. : FSF059 Option 00CG
MKT Model No. : R1CA2551B Option P00C
Hardware Rev. : A04
Software Rev. : APM12V0101

Customer
Customer PN

Approval by :

Smith Lu

Prepare by : Sonia Chuang

Date: 2021/09/24





康舒科技

ACBEL POLYTECH INC.

Contents

- 1. Specification**
- 2. Mechanical Outline Drawing**
- 3. I/O Label Drawing**
- 4. ATE test report**



康舒科技

ACBEL POLYTECH INC.

Specification



ACBEL POLYTECH INC.

R1C Series 550W

Power Module Specification

Model Number: R1CA2551B-P Series

AcBel PN: FSF059-00CG

80Plus Platinum Compliant

Note: Outward Airflow

Revision: A00

Release Date: 2015/11/04

Released by: Addy Lee

Change Date: 2020/05/04

Changed by: Rwei Zong

REVISION LOG

DATE	SECTION	REVISION	ISSUE / DESCRIPTION
2020/05/04		A00	Reference from FSF059-000G Rev A06
2020/05/04	2.1.7		The efficiency should be allowed 0.5% tolerance for MP stage.
	2.2.1		AC line voltage shall be reduced from 90VAC/60Hz to 0VAC at constant rate 1 V/secs.
	2.2.2		AC line voltage shall be increased from 0VAC to 90VAC/60Hz at constant rate 1 V/secs.
	2.3.4		For dynamic condition +12V min loading is 2A.
	2.3.6		The fan start when standby mode over 2A load, the +12Vsb output ripple noise should be reference to +240 mVp-p.
	3		Delay from PSON# de-asserted to power supply turning off(Minimum Load):TBD ms Delay from PSON# de-asserted to power supply turning off(Maximum Load):15 ms
	4.1		Logic level high (power supply OFF)from 2.7V to 2.0V.
	4.2		Power down delay: T_{pwok_off} form Max 200ms to N/A.
	4.3		Logic level high voltage, Isink=50 μ A form Min 2.4V to 0V.
	5.3		Over Voltage Limits Max(V)form 14.5V to 15V.

1. GENERAL SCOPE

This specification describes the performance characteristic of an **550W** hot swappable AC-DC switching power supply module with a +12V main DC output and a +12Vsb auxiliary output. The power supply shall be able to operate as a single supply or in an N+1 parallel hot-plug able operation with active load sharing in an N+1 redundant configuration.

2. ELETRICAL PERFORMANCE

This Chapter describes the electrical requirements and performance compliances of **R1CA2551B-P** power supply.

2.1 POWER INPUT SPECIFICATION

2.1.1 AC Input Voltage

The power supply must operate within all specified limits over the following input voltage range. Harmonic distortion of up to 10% THD must not cause the power supply to go out of specified limits.

PARAMETER	MIN	RATED	MAX	Brown Out	Brown In
Voltage (115)	90V _{rms}	100-127V _{rms}	140V _{rms}	75Vac+/-4V	85Vac+/-4V
Voltage (230)	180V _{rms}	200-240V _{rms}	264V _{rms}		
Frequency	47Hz		63Hz		

2.1.1.1 HVDC Input Voltage

The power supply supports High Voltage Direct Current (HVDC) input over the C14 Inlet. Allowed HVDC input range as shown in below table. The power supply shall operate within all specified limits, when HVDC input meet requirements defined in this chapter.

PARAMETER	MIN	RATED	MAX	Brown Out	Brown In
HVDC (240)	180V _{DC}	200-240V _{DC}	300V _{DC}	170V _{DC}	170V _{DC} ≤ V _{DC} < 180 V _{DC}

2.1.2 Inrush Current

The power supply must meet inrush requirements for any rated AC voltage; during turn on at any phase of AC voltage, during a single cycle AC dropout condition, during repetitive ON/OFF cycling of AC, and over the specified temperature range (T_{op}). The peak inrush current shall be less than the ratings of its critical components (including input fuse, bulk rectifiers, and surge limiting device), but shall not exceed 35A in general.

2.1.3 Input Current

The maximum input current defines the maximum possible input current to ensure the proper function of the power supply to meet all defined specifications.

Input	Max Current
100Vac – 127Vac	7A
200Vac – 240Vac	3.5A
240Vdc	3.5A

2.1.4 Input Power Factor Correction

The input Power Factor shall be greater than values defined in below table at power supply’s rated output, and meet Energy Star® requirements.

Output power	10% load	20% load	50% load	100% load
Power factor	>0.85	>0.95	>0.95	>0.98

Tested at 230VAC/50Hz and 115VAC/60Hz.

2.1.5 Input Current Total Harmonic Distortion (iTHD)

iTHD requirements for below table shall be meet at 25 deg. C ambient condition. Input voltage criteria shall be 115VAC/60Hz and 230VAC/50Hz.

Load Condition	10%	20%	50%	100%
115VAC	10%	10%	5%	5%
230VAC	15%	10%	10%	5%

2.1.6 AC line dropout

An Input line dropout is a transient condition defined as the line input to the power supply drops to 0 VAC at any phase of the AC line or DC line, for any length of time. During an Input dropout the power supply must meet dynamic voltage regulations requirements. An Input line dropout of any duration shall not cause dipping of the control signals and protection circuits. If the Input dropout lasts longer than defined holdup time, the power supply is allowed to shut down and recover when VIN meets VIN_{recover} and meet all turn on requirements.

An Input dropout of any length shall not cause any damage to the power supply.

Holdup time until Power output goes out of regulations

Loading	Main output	Standby output
100%	12mS	70mS

2.1.7 Efficiency

The efficiency should be measured at 230VAC for AC input power modules only according to Climate Saver / 80Plus efficiency measurement specifications (CSCI-09-10). FAN power loss shall be excluded and need to be deducted from power input.

Efficiency Std.	10% load	20% load	50% load	100% load
Platinum	82%	90%	94%	91%

Note : The efficiency should be allowed 0.5% tolerance for MP stage.

2.1.8 AC Line Transient Specification

AC line transient conditions shall be defined as “sag” and “surge” conditions.

“Sag” conditions are also commonly referred to as “brownout”, these conditions will be defined as the AC line voltage dropping below nominal voltage conditions.

“Surge” will be defined to refer to conditions when the AC line voltage rises above nominal voltage.

The power supply shall meet the requirements under the following AC line sag and surge conditions.

AC Line SAG and SURGE transient performance.

AC Line Sag and Surge (10sec interval between each sagging and surging)

Duration	Sag	Operating AC voltage	Line frequency	Performance criteria
0 to 1/2 AC cycle	95%	Nominal AC Voltage ranges	50/60Hz	No loss of function or performance
>1 AC cycle	>30%	Nominal AC Voltage ranges	50/60Hz	Loss of function acceptable, self-recoverable
Continues	10%	Nominal AC Voltages	50/60Hz	No loss of function or performance
0 to 1/2 AC cycle	30%	Mid-point of nominal AC Voltages	50/60Hz	No loss of function or performance

2.1.9 Power Recovery

The power supply shall recover automatically (auto recover) after an Input power failure. Input power failure is defined to be any loss of Input power that exceeds the dropout criteria.

2.1.10 Input Line Leakage Current

The maximum leakage current to ground for power supply system shall not exceed 3.5mA when tested at 230VAC Input voltages.

2.1.11 Surge Immunity

The power supply shall be tested with the system for immunity to AC Unidirectional wave; 2kV line to ground and 1kV line to line, per EN 55024: 1998/A1: 2001/A2: 2003, EN 6100-4-5: Edition 1.1: 2001-04.

The pass criteria include: No unsafe operation is allowed under any condition all power supply output voltage levels to stay within proper spec levels; No change in operating state or loss of data during and after the test profile No component damage under any condition.

2.2 BROWNOUT

Power supply shall contain protection circuitry such that the application of an input voltage below the minimum specified in section 2.1.3 shall not cause damage to the power supply unit nor cause failure of the input fuse and overstress to any other component. In the event of shutdown due to extended brownout, the power supply shall automatically restart after the AC input is within specified limits. The voltage level between shutdown and recovery shall have a minimum of 5 VAC of voltage hysteresis, so that the power supply will not oscillate on and off due to voltage change condition. The power supply shall meet dynamic voltage regulations (Section 2.3.3) and all turn on requirements or turn off requirements while shutdown or recovery.

2.2.1 AC Turn off Requirements

Power supply shall go to power off state after a slow brownout condition. The brownout condition shall be tested with all valid redundant power system configurations using the system. While the power system is operating at full rated DC load, the AC line voltage shall be reduced from 90VAC/60Hz to 0VAC at constant rate 1 V/secs. Power supply shall shutdown at the AC voltage 75VAC±4VAC.

2.2.2 AC Turn on Requirements

Power supply shall return to normal power up state after a slow recovery condition. The recovery shall be test ed in all valid redundant power system configurations. With the test loads configured for maximum system DC output in resistive mode, the AC line voltage shall be increased from 0VAC to 90VAC/60Hz at constant rate 1 V/secs. Power suppl y shall turn up at th e AC voltage 85VAC±4VAC.

2.3 POWER OUTPUT SPECIFICATION

2.3.1 Output Power/Currents

The following table defines the power and current rating of the **550W** power supply.

Voltage	VAC	Mini	Max	Peak ^{*see note}
+12V main	100-240	0.5A	45.8A	59.54A
+12Vsb		0.1A	3A	3.9A

1. Maximum continuous total DC output power should not exceed 550W.
2. Maximum peak total DC output power should not exceed 770W.

2.3.2 Peak Power Condition

The power supply shall meet the following peak power conditions.

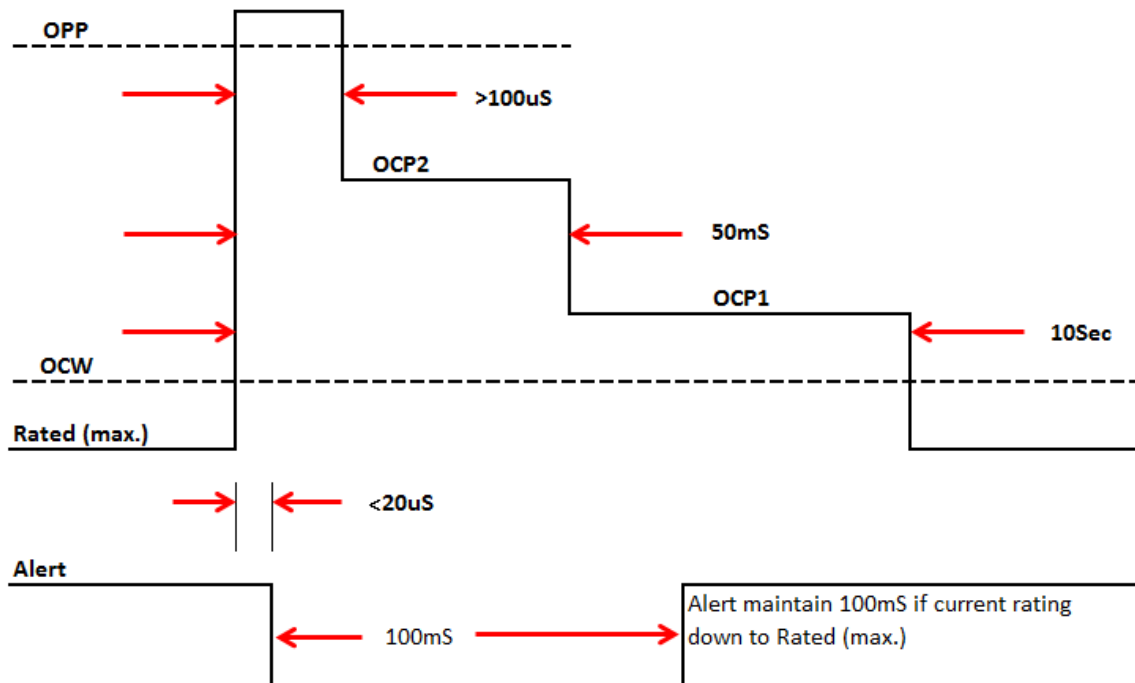

Parameter	MIN	NOM	MAX	Condition
OPP	140%	145%	150%	Keep 100uS at least
OCP2	125%	133%	140%	Keep 50mS at least
OCP1	115%	120%	125%	Keep 10Sec at least
OCW	105%	110%	115%	Continue
Rated	0%		100%	Continue

1. Peak power condition shall be following the peak power table as specify from the above after exceeding the max. Peak power threshold of T_{OFF_PEAK} , the power supply will shut down in OPP state, and according warning and failures will be reported.

2. The warning signal (OCW) will send to system during 105% - 115% of maximum load, and shuts down after follow by the specified condition.
3. After OCW event had been triggered the SMBAlert signal shall be asserted within 20uS to activate CLST. It shall be kept low for at least 100mS or longer till the system returns within 100% load or thermal condition allow it.

After OPP had been triggered the power shall be able to support 12V for at least 100uS.

2.3.3 Voltage Regulation

The power supply shall stay within the following voltage limits when operating at steady state and dynamic loading conditions. These limits include the peak-peak ripple/noise conditions specified in paragraph 2.3.6. All outputs are measured with reference to the return remote sense (ReturnS) signal.

Parameter	MIN	NOM	MAX	Units	Tolerance
+12V	+11.40	+12.00	+12.60	V _{rms}	+/-5%
+12Vsb	+11.40	+12.00	+12.60	V _{rms}	+/-5%

2.3.4 Dynamic Loading

The power supply shall operate within specified limits and meet regulation requirements for step loading and capacitive loading specified below.

The load transient repetition rate shall be tested between 50Hz to 5kHz at duty cycles ranging from 10%-90%. The load transient repetition rate is only a test specification. The Δ step load may occur anywhere within the MIN load and the MAX load.

Output	ΔStep Load Size	Load Slew Rate	Capacitive Load
+12V	60% of max load	0.5 A/μs	1,000 μF
+12Vsb	1.0A	0.5 A/μs	1,000 μF

Note : For dynamic condition +12V min loading is 2A.

2.3.5 Capacitive Loading

The power supply shall meet all requirements with the following capacitive loading ranges.

Output	MIN	MAX	Units
+12V	500	36,000	μF
+12Vsb	20	3,100	μF

2.3.6 Ripple and Noise

Ripple and Noise shall be measured over a Bandwidth of 20MHz at the power supply output connector, with minimum capacitive load as specified within paragraph 2.2.4 in parallel with a 10µF tantalum capacitor (minimum 100mΩESR) and with a 0.1µF ceramic capacitor placed at the point of measurement. Maximum allowed ripple/noise output of the power supply is defined in table below.

+12V	+12Vsb
120 mVp-p	120 mVp-p

Note : The fan start when standby mode over 2A load, the +12Vsb output ripple noise should be reference to +240 mVp-p.

The test set-up shall be as shown below:

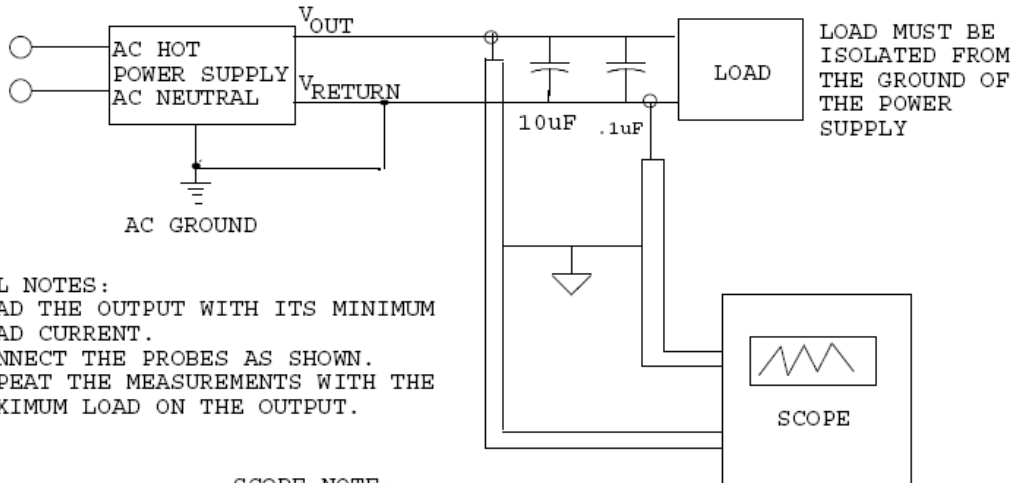

- GENERAL NOTES:
1. LOAD THE OUTPUT WITH ITS MINIMUM LOAD CURRENT.
 2. CONNECT THE PROBES AS SHOWN.
 3. REPEAT THE MEASUREMENTS WITH THE MAXIMUM LOAD ON THE OUTPUT.

SCOPE NOTE:
 USE A TEKTRONIX 7834 OSCILLOSCOPE WITH 7A13 AND DIFFERENTIAL PROBE P6055 OR EQUIVALENT.

3. TIMING REQUIREMENTS

These are the timing requirements for the power supply operation. The output voltages must rise from 10% to within regulation limits (T_{vout_rise}) within 5 to 70ms, and 1 to 25ms for 12Vsb. All main outputs must rise monotonically. Table below shows the timing requirements for the power supply begin turned on and off via the AC input, with PSON held low and the PSON signal, with the AC input applied.

Item	Description	MIN	MAX	Units
T_{vout_rise}	Output voltage rise time for 12V main output	5	70	ms
	Output voltage rise time for 12Vsb output	1	25	ms

Turn On/Off Timing

Item	Description	MIN	MAX	UNITS
$T_{sb_on_delay}$	Delay from ac begin applied to 12Vsb begin within regulation.		1500	ms
$T_{ac_on_delay}$	Delay from AC begin applied to all output voltage begin within regulation.		3000	ms
T_{out_holdup}	Time all output voltages stay within regulation after loss of AC.	13		ms
T_{pwok_holdup}	Delay from loss of AC to de-assertion of PWOK.	12		ms
$T_{pson_off_delay}$	Delay from PSON# de-asserted to power supply turning off(Minimum Load)		TBD	ms
$T_{pson_off_delay}$	Delay from PSON# de-asserted to power supply turning off(Maximum Load)		15	ms
$T_{pson_on_delay}$	Delay from PSON# active to output voltages within regulation limits.	5	400	ms
T_{pson_pwok}	Delay from PSON# de-active to PWOK begins de-asserted.		5	ms
T_{pwok_on}	Delay from output voltages within regulation limits to PWOK asserted at turn on.	100	500	ms
T_{pwok_off}	Delay from PWOK de-asserted to 12V output voltage dropping out of regulation limits.	1		ms
T_{psok_low}	Duration of PWOK begin in the de-asserted state during an off/on cycle using AC or the PSON# signal.	100		ms
T_{sb_vout}	Delay from 12Vsb begin in regulation to O/Ps begin in regulation at AC turn on.	50	1000	ms
T_{12VSB_holdup}	Time the 12VSB output voltage stays within regulation after loss of AC.	70		ms

Turn On/Off Timing (single Power supply)

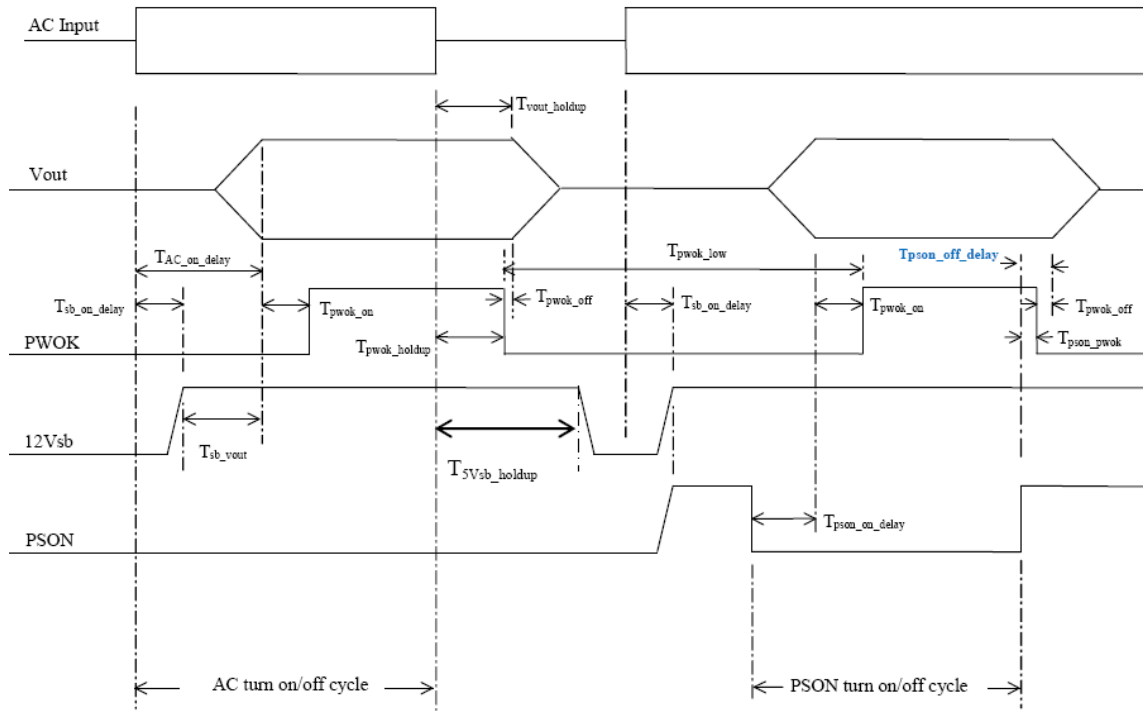

4. CONTROL AND INDICATOR FUNCTIONS

The following section defines the input and output signals from the power supply.

Signals that can be defined as low true use the following convention:

Signal[#] = low true.

4.1 PSON[#] INPUT SIGNAL (POWER SUPPLY ENABLE)

The PSON[#] signal is required to remotely turn on/off the main output of the power supply.

PSON[#] is an active low signal that turns on the main output power rail. When this signal is not pulled low by the system or left open, the outputs (except the Standby output) turn off.

PSON[#] is pulled to a standby voltage by a pull-up resistor internal to the power supply.

PSON[#] Signal Characteristic

Signal Type	Accepts a drain input from the system. Pull-up to 3.3V located in power supply	
PSON [#] = Low	ON	
PSON [#] = High or Open	OFF	
	MIN	MAX
Logic level low (power supply ON)	0V	0.6V
Logic level high (power supply OFF)	2.0V	3.46V
Source current, $V_{pson} = \text{low}$		4mA
Power off delay: $T_{pson_off_delay}$		5msec
Power up delay: $T_{pson_on_delay}$	5ms	400msec
PWOK delay: T_{pson_pwok}		50msec

4.2 POWER OK (PWOK OR PG) BUS

PWOK is a power good signal and shall be pulled HIGH by the power supply to indicate that all outputs are within regulation limits. When any output voltage falls below regulation limits, an internal failure or when AC power has been removed for a time sufficiently long, so that power supply operation is no longer guaranteed, PWOK will be de-asserted to a LOW state. The start of the PWOK delay time shall inhibited as long as any power supply output is in current limit.

PWOK / PG Signal Characteristics

Signal Type	A drain output from power supply. Pull-up 3.3V located in the power supply	
PWOK = High	Power OK	
PWOK = Low	Power Not OK	
	MIN	MAX
Logic level low voltage, $I_{sink} = 4\mu\text{A}$	0V	0.4V
Logic level high voltage, $I_{source} = 200\mu\text{A}$	2.4V	3.46V
Sink current, PWOK = low		400 μA
Source current, PWOK = high		2mA
PWOK delay: T_{pwok_on}	100ms	500ms
PWOK rise and fall time		100 μsec
Power down delay: T_{pwok_off}	1ms	

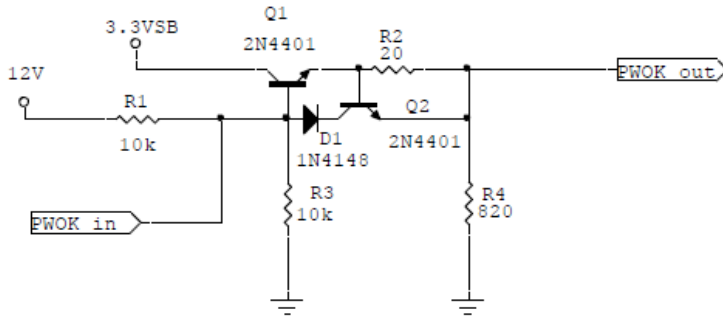

4.3 SMBAlert# Signal

This signal indicates that the power supply is experiencing a problem that the user should investigate. This shall be asserted due to Critical events or Warning events and activate in the case of SMBAlert mask setting by user(note). This signal may also indicate the power supply is reaching its end of life or is operating in an environment exceeding the specified limits. This signal is to be asserted in parallel with LED turning solid Amber or blink Amber.

Note: There are input UVP 、 output OCW 、 OTW assert SMBAlert# follow Intel SPEC.

SMBAlert# Signal Characteristics

Signal Type (Active Low)	A drain output from power supply. Pull-up to 3.3V located in power supply.	
Alert# = High	OK	
Alert# = Low	Power Alert to system	
	MIN	MAX
Logic level low voltage, Isink=4 mA	0 V	0.4 V
Logic level high voltage, Isink=50 μA		3.46 V
Sink current, Alert# = low		4 mA
Sink current, Alert# = high		50 μA

4.4 Cold Redundant_Bus (CR_BUS) Signal

This signal is used for power supply to power supply communication in front of an interrupt. This interrupt is by default low impedance low. For all power supplies connected to this bus shall have an open collector and a pull high circuitry, which can provide at least 4mA. This function shall be PMBus controlled and allows the system, to set the power module into four different modes:

1. MASTER – Load dependent function
2. SLAVE – Load dependent function
3. MASTER – HVDC Input dependent function
4. SLAVE – Master dependent function

SLAVE's in CR Standby shall provide PG and LED should be 1Hz Blink GREEN.

CR_BUS# Signal Characteristics

Signal Type (Active HIGH)	A drain output from power supply. Pull-up to 3.3V located in power supply.	
CR_BUS# = High	CR Standby Allowed	
CR_BUS# = Low	SLAVEs need to be Active ON	
	MIN	MAX
Logic level low voltage, Isink=4 mA	0 V	0.4 V
Logic level high voltage, Isource=4 mA	2.4V	3.46 V
Sink current, CR_BUS# = low		4 mA
Sink current, CR_BUS# = high		4 mA
CR_BUS# rise and fall time		100 μs

5. PROTECTION CIRCUITS

Protection circuits shall cause only the power supply’s main outputs to shutdown (latch off). If the power supply latches off due to a protection circuit tripping, an AC cycle OFF for 15 second or a PSON# cycle HIGH for 1 second must be able to reset the power supply. The auxiliary output shall not be affected by any protection circuit unless the auxiliary output itself is affected.

5.1 Output CURRENT LIMIT

The power supply shall prevent the main and auxiliary outputs from exceeding the values shown in below Table. If the main current limits are exceeded the power supply will shut down and latch off. The latch will be cleared by toggling the PSON# signal or by an AC power interruption. The power supply shall not be damage from repeated power cycling in this condition. *The auxiliary output shall be auto recover (Vsb_{AR}) after the OCP/SCP had been removed.*

Over Current Protection

Voltage	Over Current Limit (Iout limit)
+12V	110% minimum, 140% maximum
+12Vsb (Auxiliary)AR	110% minimum, 150% maximum

5.2 FAST OUTPUT CURRENT SENSING

The power supply shall have a circuit to quickly assert the SMBAlert signal when the output current exceeds the I_{throttle} threshold. A current sense resistor on the output side of the PSUs output capacitors shall be used to quickly sense current exceeding the I_{throttle} threshold. The SMBAlert# signal shall assert within T_{fast_smbalert} time. The PSU shall hold the SMBAlert# signal asserted for T_{smbalert_latch} duration then release it.

Key characteristics of the fast output current sensing requirements

- I_{throttle} < minimum OPP level (SMBAlert must assert before current/power hits the OPP threshold)
- T_{fast_smbalert} < 20uSec
- T_{smbalert_latch} = 100mSec (+/-50mSec)

5.3 Output OVER VOLTAGE PROTECTION

The power supply shall shutdown and latch off after the over voltage condition has occurred. This latch will be cleared by toggling the PSON# signal or by an AC power interruption. A shutdown caused by an over-voltage in one power supply will not cause the other (redundant) power supply to shuts down. The over-voltage threshold is defined in table below.

Output Voltage	MIN (V)	MAX (V)
+12V	13.8	15
+12Vsb (<i>Auxiliary</i>)AR	13.3	15

5.4 OVER TEMPERATURE PROTECTION

The power supply shall be protected against over temperature conditions caused by loss of fan cooling or excessive ambient temperature which could cause internal part failures. In an over temperature condition the power supply shall shutdown, then recover after while the temperature back in normal condition. The 12VSB shall not shutdown during an OTP condition on the main outputs.

The temperature warning setting point is showing on below table:

Condition	Warning in °C	Critical in°C	Timing for LED	Timing for SMBAlert
T _{READ}	60	65	1sec	100usec

T_{READ}: Environment Temperature

6. LED IDENTIFICATION

There is one indicator LED located on the front faceplate. Status showing on below:

Power Supply Condition	LED State
Output ON and OK	GREEN
Only 12Vsb on (PS off) or PSU in Cold redundant state	1Hz Blink GREEN
Power supply warning events where the power supply continues to operate high temp, high power, high current, slow FAN.	1Hz Blink AMBER
Power supply critical event causing a shutdown; AC cord unplugged or AC power lost, failure, OCP, OVP, FAN fail.	AMBER

7. POWER SUPPLY MANAGEMENT

7.1 HARD WARE LAYER

The serial bus communication devices for Power Supply Management Controller (PSMC) and Field Replacement Unit (FRU) in the power supply shall be compatible with both SMBus 2.0 “high power” and I²C Vdd based power and drive specification.

This bus shall operate at 3.3V. The power supply should have internal pull-ups on the SMBus. Two pins are allocated on the power supply. One pin is the serial clock (SCL). The second pin is used for serial data (SDA). Both pins are bi-directional and are used to form a serial bus. The device(s) in the power supply shall be located at an address(s) determined by addressing pins A0 and A1 on the power supply module. The circuits inside the power supply shall derive their 3.3V power from the 12VSB bus through a buffer. Pull-up resistors shall be on SCL or SDA inside the power supply. Pull-up resistor is 10K ohm for SDA and SCL separately.

7.1.1 Capacitance for SMBus

The recommended Capacitance per pin on SDA and SCL shall be 10pF, and is not allowed to exceed 40pF per pin. In an N+1 configuration of up to four (4) power modules with additional PDB, the total Capacitance of each Bus pin shall not exceed 400pF.

7.1.2 I²C Bus Noise Requirement

The power supplies I²C Bus’ SDA and SCL line shall be clean from noise, which might affect the proper function when utilized with other devices.

The maximum allowed line noise on SDA or SCL is 200mV.

7.2 POWER SUPPLY MANAGEMENT CONTROLLER (PSMC)

The PSMC device on the PDB shall derive its power of the 12Vsb output on the system side of the O’ring device and shall be grounded to return. It shall be compatible with SMBus specification 2.0 and PMBus™ Power System Management Protocol Specification Part I and Part II in Revision 1.2 or later

It shall be located at the address set by the A0 and A1 pins.

Refer to the specification posted on www.ssiforum.org and www.pmbus.org website for details on the power supply monitoring interface requirements and refer to followed section of supported features. The below table reflect the power module addresses complying with the position in the housing.

PDB position and PSMC address	PM1 B0h/B1h	PM2 B2h/B3h	PM3 B4h/B5h	PM4 B6h/B7h
Pin A0/A1	0/0	1/0	0/1	1/1

Note: Pull-up resistor is 14.3K ohm for A0 and A1 separately.

7.2.1 Power Supply Field Replacement Unit (FRU)

The power supply shall support electronic access of FRU information over an I²C bus. Six pins at the power supply connector are allocated for this. They are named SCL, SDA, A2, A1, A0 and Write protect. SCL is serial clock. SDA is serial data. These two bidirectional signals from the basic communication lines over the I²C bus. A0, A1 and A2 are input address lines to the power supply. The backplane defines the state of these lines such that the address to the power supply is unique within the system. The resulting I²C address shall be per table below. The Write protection pin is to ensure that data will not accidentally overwritten.

The device used for this shall be powered from a 3.3V bias voltage derived from the +12 VSB output . No pull-up resistors shall be on SCL or SDA inside the power supply.

PDB position and FRU address	PM1	PM2	PM3	PM4
	A0h/A1h	A2h/A3h	A4h/A5h	A6h/A7h
Pin A1/A0	0/0	0/1	1/0	1/1

7.3 Sensor Accuracy

The sensor of the PSMC shall meet below accuracy requirements for sensor readings. The accuracy shall be met at the specified environmental condition and the full range of rated input voltage.

Sensor Accuracy Table

Sensor	0%-10% load	>10%-20% load	>20%-100% load
Current	± 5% or 0.5A	± 5% or 0.5A	± 3%
Voltage	± 5%	± 3%	± 3%
Output Power	± 10W	± 5% or 10W	± 3%
Temperature	± 3°C with Δ5%		
FAN	± 10% from Spec.		
Input Power	± 10W	± 5%	± 3%

8. ENVIRONMENTAL

8.1 TEMPERATURE REQUIREMENTS

The power supply shall operate within all specified limits over the Top temperature range. The average air temperature difference (ΔT_{ps}) from the inlet to the outlet of the power supply shall not exceed the values shown below Table. All airflow shall pass through the power supply and not over the exterior surfaces of the power supply

ITEM	DESCRIPTION	MIN	MAX	UNITS
Top	Operating temperature range.	0	50	°C
Tnon-op	Non-operating temperature range.	-40	70	°C

8.2 HUMIDITY

Operating: 10% to 95% relative humidity, non-condensing.
Storage: 10% to 95% relative humidity, non-condensing.

8.3 ALTITUDE

Operating: to 5,000m
Non-operating: to 15,200m

8.4 VIBRATION

Operating: 0.01G²/Hz at 10Hz, 0.02G²/Hz at 20Hz.
Non-Operating: 0.02G²/Hz form 20Hz to 1000Hz.

8.5 MECHANICAL SHOCK

Operating: 5G, no malfunction.
Non-operating: 50G, no damage. Trapezoidal Wave, Velocity change = 4.3m/sec. Three drops in each of six directions are applied to each of the samples.

8.6 EMI/EMC REQUIREMENTS

The power supply shall comply with FCC part 15, CRISP 22 and EN55-22; Class A for both conducted and radiated emissions with a 3dB margin. Test shall be conducted using a shielded DC output cable to a shielded load. The load shall be adjusted to 100% load. Tests will be performed full load on each output power at 120VAC, 60Hz, and 230VAC, 50Hz.

9. REGULATORY REQUIREMENTS

9.1 PRODUCT SAFETY COMPLIANCE

The power supply will have the following safety approvals with most current editions:

- A) UL 60950-1/CSA 60950-1 Edition 2 (USA/Canada)
- B) TUV EN60950-1 Edition 2 (Europe)
- C) IEC60950-1 Edition 2 (International)
- D) CB Certificate & Report, IEC60950-1 Edition 2
- E) CE – Low Voltage Directive 2006/95/EC (Europe)
- F) BSMI (Taiwan)
- G) GB4943-2011 Certification (China)
- H) KCC (Korea)

9.2 ELECTROSTATIC DISCHARGE

The objective of ESD test is to determine the susceptibility and immunity of products to electrostatic discharge to which the products may be exposed, when operating under all potential environmental conditions. The test conditions and setup shall conform to that outlined in CISPR24-2 and IEC 801-2 (EN55101-2).

Air discharge: 8KV not allow error.

Contact discharge: 4KV not allow error.

Note: The above test discharge time is 1 time/sec and repeats each test 10 times.

9.3 HI-POT

The power supply module in the system shall be test at 1800Vac, with a trigger limit of 30mA.

10. RELIABILITY

The MTBF of the power supply can be calculated with the Part-Stress Analysis method of Bell Core SR332 of the quality factors. A calculated MTBF of the power supply shall be at least 100,000 hours at 50°C ambient with 230VAC and in full load condition.

10.1 Electrolyte Capacitor Life

The used electrolyte capacitor shall have a minimum life of 5 years.

- Perform the test for 230Vac/50Hz input voltage.
- Perform the test for 80% maximum load and Only Standby Load(3A).
- Perform the test at 35°C ambient temperature.

11. RoHS COMPLIANCE

The directive 2002/95/EC of the European Parliament and of the Council of the 27th January 2003, on the restriction of the use of certain hazardous substances in electrical and electronic equipment, requires the reduction of the substances Lead, Mercury, Cadmium, Hexavalent Chromium, Polybrominated Biphenyls (PBB), and Polybrominated Biphenyl ethers (PBDE) in electronic products by July 1, 2006. Unless otherwise noted, all materials used will be compliant with this directive and any subsequent revisions or amendments.

12. MECHANICAL DIMENSIONS

Dimension (L x W x H): 185 x 73.5 x 40mm / 7.28 x 2.89 x 1.57inch

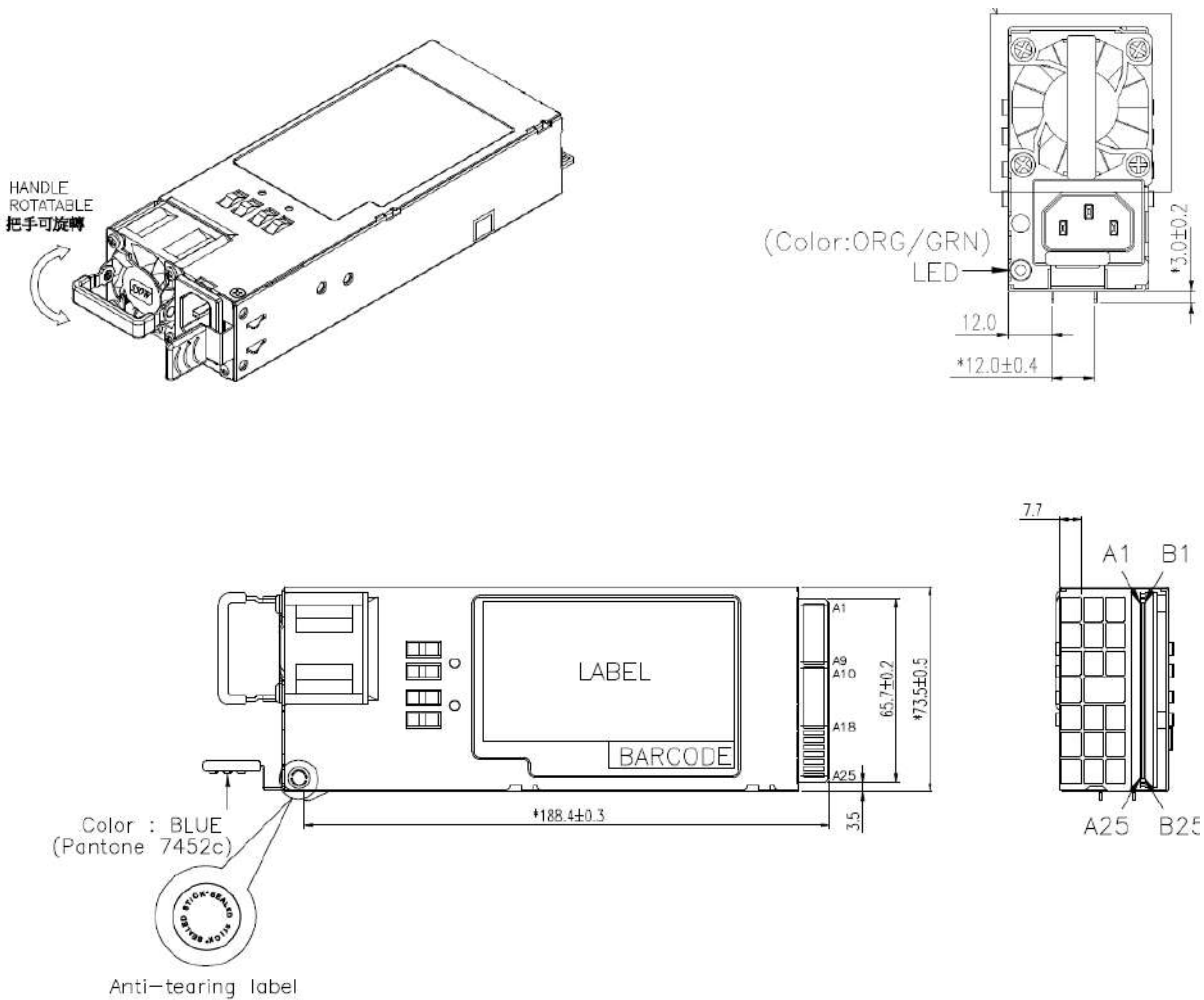

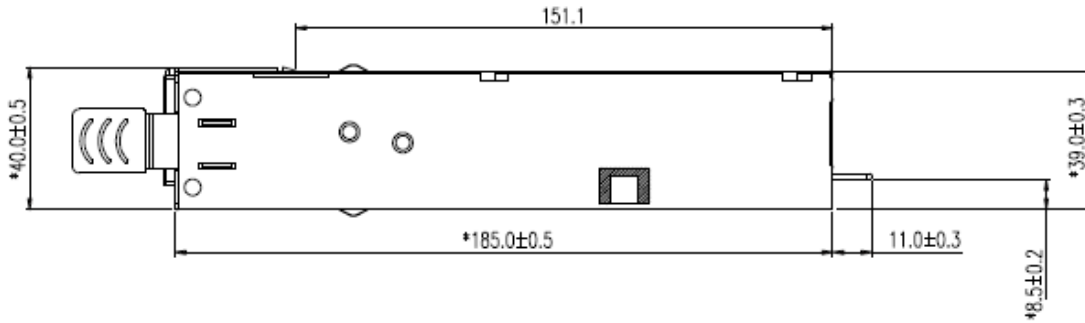

NOTE: Above drawing is for reference only, detail dimension should refer to independent mechanical drawing.

The height of adapter gold finger to the bottom is 8.5mm

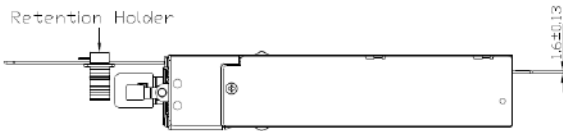
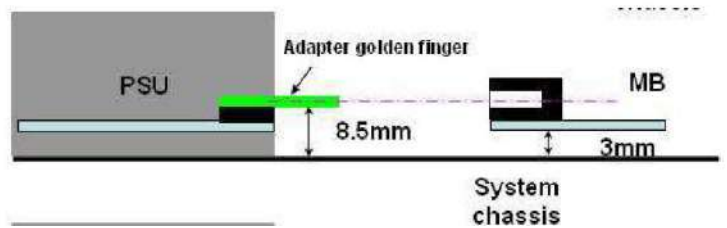

12.1 DC Output connector

The power supply shall use a card edge output connection for power and signal that is compatible with a 2x25 Power Card Edge connector (equivalent to 2x25 pin configuration of the FCI power card connector 10035388-102LF or ALLTOP C21009-102H3-Y).

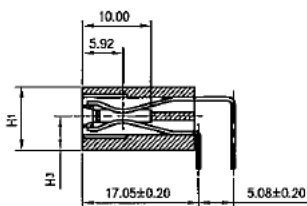
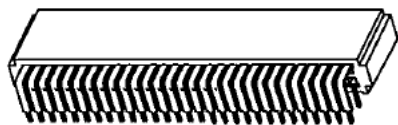
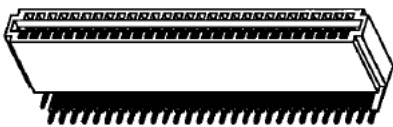

FCI 2x25 card edge connector 10035388-102

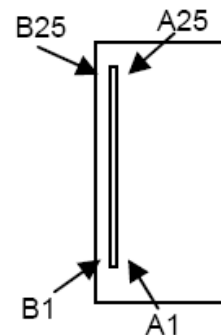

Gold finger pin assignment

OUTPUT PIN ASSIGNMENT

PIN	SIGNAL_NAME	PIN	SIGNAL_NAME
A1	GND	B1	GND
A2	GND	B2	GND
A3	GND	B3	GND
A4	GND	B4	GND
A5	GND	B5	GND
A6	GND	B6	GND
A7	GND	B7	GND
A8	GND	B8	GND
A9	GND	B9	GND
A10	+12V	B10	+12V
A11	+12V	B11	+12V
A12	+12V	B12	+12V
A13	+12V	B13	+12V
A14	+12V	B14	+12V
A15	+12V	B15	+12V
A16	+12V	B16	+12V
A17	+12V	B17	+12V
A18	+12V	B18	+12V
A19	PMBus SDA	B19	A0 (SMBus address)
A20	PMBus SCL	B20	A1 (SMBus address)
A21	PSON	B21	12VSB
A22	SMBAAlert#	B22	CR_BUS#
A23	Return Sense	B23	12V load share Bus
A24	+12V Remote Sense	B24	NC (Reserved)*
A25	PWOK	B25	NC

*Default is internally pulled low after initial.

Description Gold finger

OUTPUT PIN DEFINITION

Pin No.	Pin Name	Pull Up Resistor	Description
A1~A9 B1~B9	GND	N/A	12V main & 12VSB Return
A10~A18 B10~B18	12V	N/A	12V main output
A19	SDA	10K ohm is pulled high to 3.3V(damping 47ohm)	SMBus/PMBus Data
A20	SCL	10K ohm is pulled high to 3.3V(damping 47ohm)	SMBus/PMBus Clock
A21	PSON	14.3K ohm is pulled high to 3.3V	Active low; 12V main output on/off control
A22	SMBAlert	5.1K ohm is pulled high to 3.3V, 0 ohm is pull low to GND.	Active High; Alert Signal (interrupt)
A23	RETURN_S	N/A	12V main output Remote Sense (-)
A24	+12VRS	N/A	12V main output Remote Sense (+)
A25	PWOK	20 ohm is pulled high to 3.3V, 820 ohm is pulled low to GND	Active high; Indicate 12V main is valid.
B19	A0	14.3K ohm is pulled high to 3.3V	PMBus Address 0
B20	A1	14.3K ohm is pulled high to 3.3V	PMBus Address 1
B21	12VSB	N/A	Standby Voltage
B22	CR_Bus#	Connect to other PSU b22	Cold Redundant BUS
B23	12VLS	Connect to other PSU b23.	12V main output load current sharing
B24	N/A	N/A	Power Supply Reserved
B25	NC	N/A	Not connect



康舒科技

ACBEL POLYTECH INC.

Mechanical Outline Drawing

2017/03/13 09:55:00

RELEASE

MO-FSF059-00AG_01

105217林建廷JianTing_Lin

NOTE :

1. UNIT : MM. 單位 : 毫米
2. MATERIAL : SGCC. 材質 : SGCC
THICKNES : COVER 0.8 mm , CHASSIS 0.8 mm
厚度 : 上蓋 0.8 mm , 下蓋 0.8 mm
3. NET WEIGHT : 800g±3% 淨重 : 800克 ±3%
4. " * " CRITICAL DIMENSION. THE SUPPLIER COMPLY TO ACBEL SPEC DIMENSION FOR EVERY SHIPMENT.
" * " 表示該(尺寸/位置)為設計之重點尺寸, 供應商每次出貨前必須檢驗合格後, 方可出貨。
5. THESE MATERIAL/PART/ASSEMBLY MUST COMPLY TO ACBEL SPEC "CRITERIA FOR ENVIRONMENT-RELATED SUBSTANCES".
材質/零件/製程均必須符合康舒"環境管理物質規範".

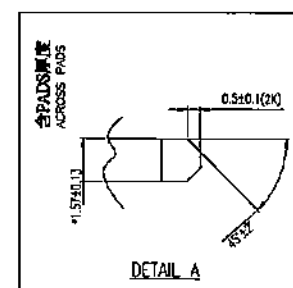
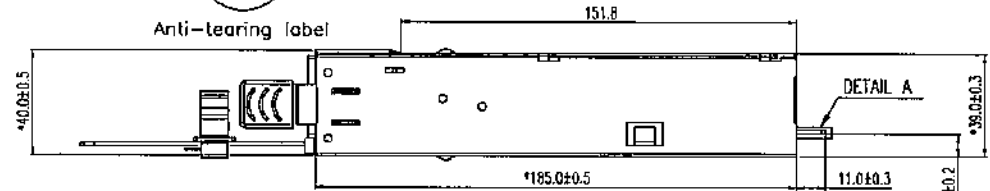
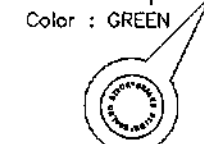
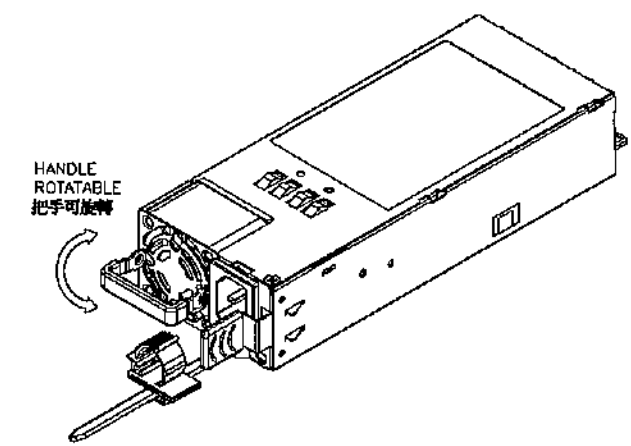
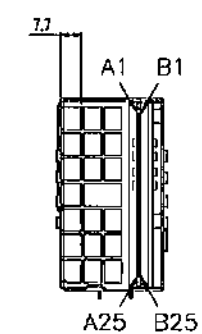
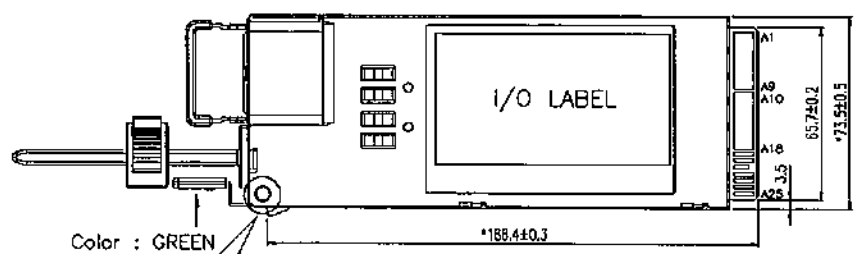
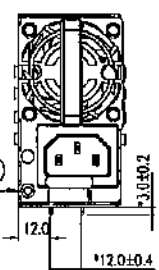
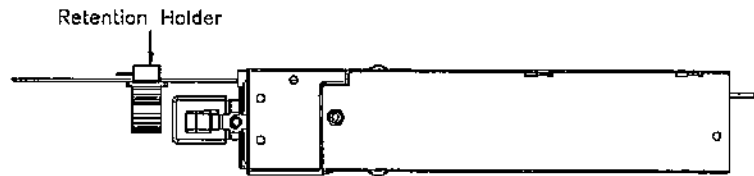
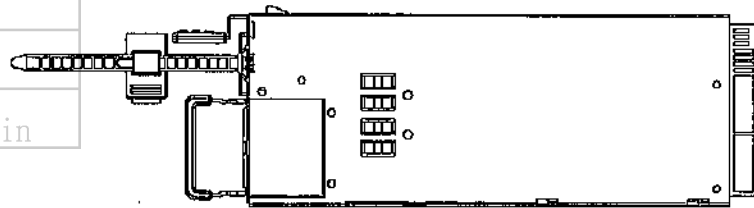

RELEASE	
正式發行圖面	
ENG. JianTing	REV: A
APPR. [Signature]	

A	RELEASE	JianTing 02/24/17
1	PRIMARY	JianTing 02/24/17
REV	DESCRIPTION	BY DATE
ACBel ACBEL POLYTECH INC.		MODEL NO. FSF059-00CG
		PART NO. MO-FSF059-00CG
		DWG NO. MO-FSF059-00CG_A
SI Metric A1		TITLE MECHANICAL OUTLINE
THIRD ANGLE PROJECTION		DESIGNER JianTing 02/24/17
		CHECKED [Signature]
SCALE NONE		APPROVED [Signature]
SHEET 1 OF 1		

A105217



康舒科技

ACBEL POLYTECH INC.

I/O Label Drawing

厂内自印(详细见条码及文字内容说明
参考NOTE 16/17 虚线不列印)

AcBel MODEL 型号(型号): R1CA2551B
SWITCHING POWER SUPPLY
开关电源(交换式电源供应器)
OPTION : REV. :
FRU :
AC INPUT : 交流输入(交流输入)
100-127V~, 50/60Hz, 7.0A
200-240V~, 50/60Hz, 3.5A
OR 或(或) DC INPUT : 直流输入(直流输入)
240V --- 3.5A MAX
DC OUTPUT : 直流输出(直流输出)
+ 12.0V --- 45.8A
+ 12Vsb --- 3.0A
TOTAL POWER 550W MAX.
最大总功率550W(最大总功率550W)
MADE IN CHINA 中国制造(中国製造)
Acbel Polytech (UK) Limited
For UK only : 9 Royal Crescent Glasgow G3 7SP

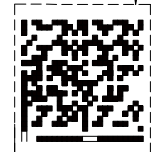

IS 13252 (Part 1)
IEC60950-1

R-41013579
www.bis.gov.in

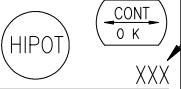

This device complies with Part 15 of the FCC Rules.
Operation is subject to the following two conditions:
(1) This device may not cause harmful interference, and
(2) this device must accept any interference received,
including interference that may cause undesired operation.

警告使用者:
此为甲類資訊技術設備,於居住環境中使用時,可能會造成射頻擾動,在此種情況下,使用者會被要求採取某些適當的對策。
警告:
此为A级产品,在生活环境中,该产品可能会造成无线电干扰。在这种情况下,可能需要用户对干扰采取切实可行的措施。



厂内自印 NOTE 11
(同SN字印原则)

虚线不列印

此虚线处请由厂商套印厂别码,请参考NOTE19

SN自印原则:

1 2 3 4 5 6 7 8 9 10 11 12 13 14 15 16 17 18 19 20 21 22 23 24

□ □ □ □ □ N N N N N N N X Y Y W W S S S S S S

RELEASE
正式發行圖面 REV: G
ENG. Ting APPR.

SERIAL NO 000001~999999

DATE CODE(YY : YEAR WW:WEEK
FOR EXAMPLE : 2012 13TH WEEK 则此4栏位为"1213")

MFG. FACTORY CODE:
(东莞康舒印: B ; 东莞康展印: T ; 武汉康舒印: W)

ID CODE (Ex. : 若机种FSA035-001G印001G)

API REVISION CONTROL CODE (S1印 : 0S1 ; S2印 : 0S2 ; A印 : A00)

API PART NUMBER (Ex. : 若机种FSA035-001G, 则印制" FSA035"于此6个栏位)

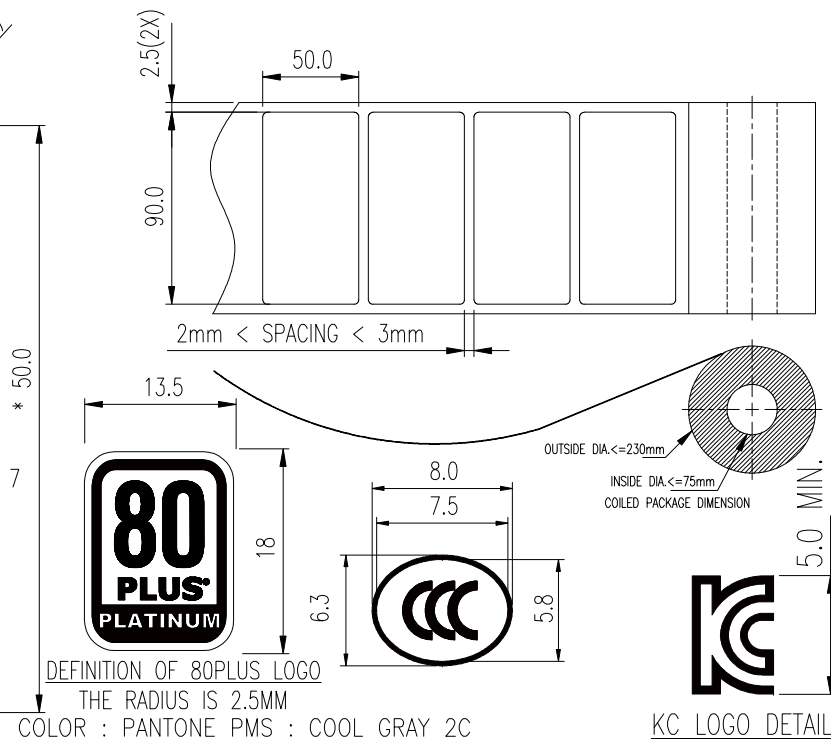

G	UKCA ADDRESS Cresscent -> Crescent	TING	08/13/21
F	ADD UKCA LOGO	TING	03/12/21
E	ADD FCC WARNING STATEMENTS	TING	09/27/18
D	3C LOGO REMOVE S&E	TING	08/15/18
C	ADD BIS LOGO & CHANGE BSMI LOGO TO BSMI RoHS	JianTing	06/06/17
A	RELEASE	Y.C	08/24/16
1	PRIMARY	JACKY	04/19/16
REV	DESCRIPTION	BY	DATE

AcBel ACBEL POLYTECH INC.	MODEL NO.	FSF059-00AG	
	PART NO.	R01AAA-7493IF	
	DWG. NO	R01AAA-7493IF_G	
SI Metric A3	THIRD ANGLE PROJECTION		TITLE I/O LABEL
	DESIGNER	TING	
SCALE	NONE	SHEET 1 OF 2	APPROVED

NOTES:

1. UNIT : MM.
单位：毫米
2. MATERIAL :
2.1 FACE STOCK 底材 :
WHITE POLYESTER, THICKNESS = 0.05 MM.
白雾龙50#, 厚度= 0.05毫米
- 2.2 OVERLAMINATION 保护膜 :
 A TRANSPARENT FILM 透明胶膜 NONE 无
- 2.3 ADHESIVE 背胶 : PRESSURE SENSITIVE ACRYLIC 压克力压膜胶
THICKNESS 厚度 = 0.025 MM
- 2.4 BACKED WITH RELEASE LINER. 背面附离型纸
- 2.5 LABEL TO BE AFFIXED TO AND MAXIMUM TEMPERATURE RATING 贴纸所贴附之材质与最大耐温等级 :
 GALVANIZED STEEL 镀锌钢 ALUMINUM 铝
 NICKEL PLATED METAL 镀镍金属
 ZINC PLATED METAL WITH CHROMATE POST TREATMENT 后处理之镀铬酸锌金属
 100°C 摄氏100度
- 2.6 MATERIAL MUST BE UL RECOGNIZED AND COMPLY TO UL 969 STANDARD.
材质必须符合 UL 认证, 并且遵从 UL 969 标准.
3. LABEL MUST BE MADE BY A UL RECOGNIZED AND CSA APPROVED VENDOR.
贴纸之制造商必须是 UL 与 CSA 所认证.
4. TOLERANCE : XX = +/- 0.5 XX.X = +/- 0.2
XX.XX = +/- 0.15
公差 : XX = +/- 0.5 XX.X = +/- 0.2
XX.XX = +/- 0.15
5. "*" CRITICAL DIMENSION SYMBOL, SUPPLIER MUST INSPECT THIS DIMENSION FOR EVERY SHIPMENT
"*" 表示该(尺寸/位置)为设计之重点尺寸, 供应商每次出货前必须检验合格后, 方可出货.
6. ALL PRODUCTS MUST BE THE SAME AS ENGINEERING API MECHANICAL ENGINEERING APPROVED SAMPLES, ANY MODIFICATION MUST BE APPROVED BY ACBEL MECHANICAL ENGINEERING SECTION.
所有产品必须与认可的样品一致, 任何的修改都必须经由康舒机构工程师同意及认可.
7. LABEL MUST CONTAIN THE VENDOR'S ID MARK LOCATED IN THE AREA INDICATED. ID MARK LETTER HEIGHT TO BE 1.5MM.
贴纸必须印制厂商代码, 代码字高为 1.5 毫米.
8. CHARACTER HEIGHT : 1.5 MM , UNLESS OTHERWISE SPECIFIED.
图面未标示之字体高度皆为 1.5 毫米
9. PRINTED COLOR :
BLACK - TEXT, GRAPHICS, IMAGE, LOGO SURROUND SHAPE.
WHITE - BACKGROUND.
列印颜色 :
黑色 - 文字、图形、图象、标志、外围图形 白色 - 背景

10. THESE MATERIAL/PART/ASSEMBLY MUST COMPLY TO ACBEL SPEC"CRITERIA FOR ENVIRONMENT-RELATED SUBSTANCES".
材质/零件/制程必须符合康舒"环境管理物质规范".
20. USES OF RED PHOSPHORUS MATERIAL IS PROHIBITED
禁止使用含有红磷材料

11. BAR CODE FORMAT: CODE 128 / CPI : 13.64
THE NARROW ELEMENT DIMENSION (X DIMENSION) SHOULD BE WITHIN A RANGE OF 0.170MM(0.0067 INCH)
条码格式 : CODE 128 / CPI 13.6毫/窄比 : 0.17毫米(0.0067英寸)

12. BAR CODE & SN & FRU 厂内自印
13. REV : XXX (S1印 : 0S1 ; S2印 : 0S2 ; A印 : A00)
14. DATE : YYYYWW 为厂内自印, 4码 YYWW为制造周期, X为工厂代码*
工厂代码 : 康舒东莞厂印B, 康展东莞厂印T, 康舒武汉厂印W

15. FRU自印原则

AXXSS□□□□□

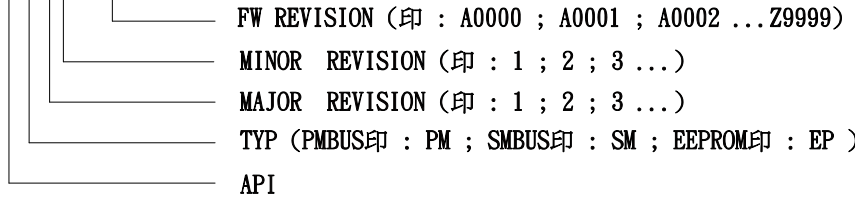

16. 条码自印原则

XXXXXXXXXX;00000NNNNNNNXYWWSSSSSS;YYMMDD;XXXXXXXXXX

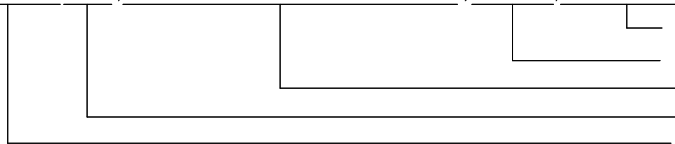

17. 条码及文字内容说明

编码: DATAMATRIX

18. 警告符号颜色定义如下 :

- PMC BlackC黑色 - 文字 . 图形 . 图象 . 标志
- PMC 108C黄色 - 背景

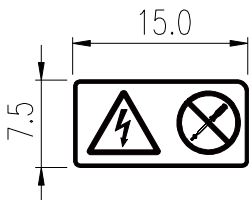

19. 加入工厂代码, 如康舒东莞厂生产即印制(B)如图所示, 如康展东莞厂生产即印制(T); 如康舒武汉厂生产即印制(W)

IS 13252 (Part 1)
IEC60950-1



R-xxxxxxx
www.bis.gov.in

字体: Arial
字号: 6pt



RELEASE			
正式發行圖面		REV: G	
ENG.	Ting	APPR.	

 ACBEL POLYTECH INC.		MODEL NO.	FSF059-00AG	
		PART NO.	R01AAA-7493IF	
 THIRD ANGLE PROJECTION		DWG. NO :	R01AAA-7493IF_G	
		TITLE	I/O LABEL	
		DESIGNER	TING	08/13/21
SCALE NONE		CHECKED		
SHEET 2 OF 2		APPROVED		







康舒科技

ACBEL POLYTECH INC.

ATE Test Report

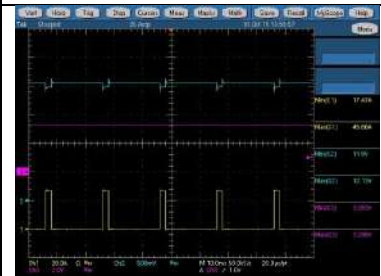

12V Dynamic									
Input		Period	Output		Test Limits		Test Results		Pass/Fail
Vin	Freq		12V	12Vsb	Min	Max	Min	Max	
90.00	63.00	50Hz/10%	1~27.3	2	11.400	12.600	11.957	12.167	PASS
			1~28.44	0.1	11.400	12.600	11.958	12.170	PASS
			17.53~43.83	2	11.400	12.600	11.906	12.128	PASS
			18.29~45.73	0.1	11.400	12.600	11.902	12.130	PASS
		500Hz/10%	1~27.3	2	11.400	12.600	11.920	12.182	PASS
			1~28.44	0.1	11.400	12.600	11.950	12.184	PASS
			17.53~43.83	2	11.400	12.600	11.899	12.134	PASS
			18.29~45.73	0.1	11.400	12.600	11.892	12.138	PASS
		5kHz/10%	1~27.3	2	11.400	12.600	12.019	12.132	PASS
			1~28.44	0.1	11.400	12.600	12.023	12.129	PASS
			17.53~43.83	2	11.400	12.600	11.970	12.102	PASS
			18.29~45.73	0.1	11.400	12.600	11.968	12.102	PASS
264.00	47.00	50Hz/10%	1~27.3	2	11.400	12.600	11.957	12.165	PASS
			1~28.44	0.1	11.400	12.600	11.954	12.174	PASS
			17.53~43.83	2	11.400	12.600	11.908	12.127	PASS
			18.29~45.73	0.1	11.400	12.600	11.902	12.134	PASS
		500Hz/10%	1~27.3	2	11.400	12.600	11.920	12.181	PASS
			1~28.44	0.1	11.400	12.600	11.950	12.186	PASS
			17.53~43.83	2	11.400	12.600	11.898	12.135	PASS
			18.29~45.73	0.1	11.400	12.600	11.891	12.138	PASS
		5kHz/10%	1~27.3	2	11.400	12.600	12.019	12.134	PASS
			1~28.44	0.1	11.400	12.600	12.020	12.127	PASS
			17.53~43.83	2	11.400	12.600	11.971	12.102	PASS
			18.29~45.73	0.1	11.400	12.600	11.975	12.103	PASS
90.00	63.00	50Hz/50%	1~27.3	2	11.400	12.600	11.959	12.165	PASS
			1~28.44	0.1	11.400	12.600	11.956	12.173	PASS
			17.53~43.83	2	11.400	12.600	11.914	12.123	PASS
			18.29~45.73	0.1	11.400	12.600	11.902	12.133	PASS
		500Hz/50%	1~27.3	2	11.400	12.600	11.974	12.196	PASS
			1~28.44	0.1	11.400	12.600	11.984	12.217	PASS
			17.53~43.83	2	11.400	12.600	11.903	12.142	PASS
			18.29~45.73	0.1	11.400	12.600	11.899	12.146	PASS
		5kHz/50%	1~27.3	2	11.400	12.600	11.961	12.179	PASS
			1~28.44	0.1	11.400	12.600	11.956	12.186	PASS
			17.53~43.83	2	11.400	12.600	11.934	12.148	PASS
			18.29~45.73	0.1	11.400	12.600	11.929	12.151	PASS
264.00	47.00	50Hz/50%	1~27.3	2	11.400	12.600	11.956	12.169	PASS
			1~28.44	0.1	11.400	12.600	11.956	12.171	PASS
			17.53~43.83	2	11.400	12.600	11.908	12.128	PASS
			18.29~45.73	0.1	11.400	12.600	11.905	12.128	PASS
		500Hz/50%	1~27.3	2	11.400	12.600	11.974	12.195	PASS
			1~28.44	0.1	11.400	12.600	11.984	12.217	PASS
			17.53~43.83	2	11.400	12.600	11.903	12.141	PASS
			18.29~45.73	0.1	11.400	12.600	11.899	12.145	PASS
		5kHz/50%	1~27.3	2	11.400	12.600	11.963	12.179	PASS
			1~28.44	0.1	11.400	12.600	11.957	12.185	PASS
			17.53~43.83	2	11.400	12.600	11.930	12.146	PASS
			18.29~45.73	0.1	11.400	12.600	11.930	12.148	PASS

90.00	63.00	50Hz/90%	1~27.3	2	11.400	12.600	11.959	12.169	PASS
			1~28.44	0.1	11.400	12.600	11.964	12.169	PASS
			17.53~43.83	2	11.400	12.600	11.907	12.128	PASS
			18.29~45.73	0.1	11.400	12.600	11.906	12.130	PASS
		500Hz/90%	1~27.3	2	11.400	12.600	11.979	12.185	PASS
			1~28.44	0.1	11.400	12.600	11.977	12.190	PASS
			17.53~43.83	2	11.400	12.600	11.912	12.140	PASS
			18.29~45.73	0.1	11.400	12.600	11.908	12.145	PASS
		5kHz/90%	1~27.3	2	11.400	12.600	11.994	12.115	PASS
			1~28.44	0.1	11.400	12.600	11.995	12.118	PASS
			17.53~43.83	2	11.400	12.600	11.954	12.070	PASS
			18.29~45.73	0.1	11.400	12.600	11.950	12.069	PASS
264.00	47.00	50Hz/90%	1~27.3	2	11.400	12.600	11.959	12.170	PASS
			1~28.44	0.1	11.400	12.600	11.958	12.176	PASS
			17.53~43.83	2	11.400	12.600	11.908	12.124	PASS
			18.29~45.73	0.1	11.400	12.600	11.906	12.125	PASS
		500Hz/90%	1~27.3	2	11.400	12.600	11.980	12.184	PASS
			1~28.44	0.1	11.400	12.600	11.977	12.191	PASS
			17.53~43.83	2	11.400	12.600	11.912	12.140	PASS
			18.29~45.73	0.1	11.400	12.600	11.907	12.145	PASS
		5kHz/90%	1~27.3	2	11.400	12.600	11.994	12.116	PASS
			1~28.44	0.1	11.400	12.600	11.996	12.116	PASS
			17.53~43.83	2	11.400	12.600	11.952	12.071	PASS
			18.29~45.73	0.1	11.400	12.600	11.949	12.071	PASS

		
90Vac, 50Hz, 10% Duty, 12V@1~27.3A ;12Vsb@2A, CH1:+12V current, CH2:+12V, CH3:PG	90Vac, 50Hz, 10% Duty, 12V@1~28.44A ;12Vsb@0.1A, CH1:+12V current, CH2:+12V, CH3:PG	90Vac, 50Hz, 10% Duty, 12V@17.53~43.83A ;12Vsb@2A, CH1:+12V current, CH2:+12V, CH3:PG
		
90Vac, 50Hz, 10% Duty, 12V@18.29~45.73A ;12Vsb@0.1A, CH1:+12V current, CH2:+12V, CH3:PG	90Vac, 500Hz, 10% Duty, 12V@1~27.3A ;12Vsb@2A, CH1:+12V current, CH2:+12V, CH3:PG	90Vac, 500Hz, 10% Duty, 12V@1~28.44A ;12Vsb@0.1A, CH1:+12V current, CH2:+12V, CH3:PG

<p>90Vac, 500Hz, 10% Duty, 12V@17.53~43.83A ;12Vsb@2A, CH1:+12V current, CH2:+12V, CH3:PG</p>	<p>90Vac, 500Hz, 10% Duty, 12V@18.29~45.73A ;12Vsb@0.1A, CH1:+12V current, CH2:+12V, CH3:PG</p>	<p>90Vac, 5kHz, 10% Duty, 12V@1~ 27.3A ;12Vsb@2A, CH1:+12V current, CH2:+12V, CH3:PG</p>
<p>90Vac, 5kHz, 10% Duty, 12V@1~ 28.44A ;12Vsb@0.1A, CH1:+12V current, CH2:+12V, CH3:PG</p>	<p>90Vac, 5kHz, 10% Duty, 12V@17.53~43.83A ;12Vsb@2A, CH1:+12V current, CH2:+12V, CH3:PG</p>	<p>90Vac, 5kHz, 10% Duty, 12V@18.29~45.73A ;12Vsb@0.1A, CH1:+12V current, CH2:+12V, CH3:PG</p>

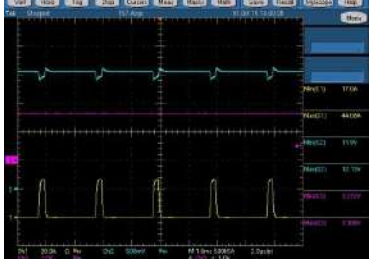
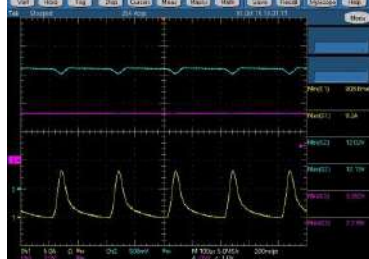
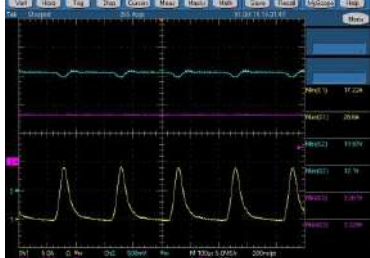
<p>264Vac, 50Hz, 10% Duty, 12V@1~ 27.3A ;12Vsb@2A, CH1:+12V current, CH2:+12V, CH3:PG</p>	<p>264Vac, 50Hz, 10% Duty, 12V@1~ 28.44A ;12Vsb@0.1A, CH1:+12V current, CH2:+12V, CH3:PG</p>	<p>264Vac, 50Hz, 10% Duty, 12V@17.53~43.83A ;12Vsb@2A, CH1:+12V current, CH2:+12V, CH3:PG</p>
<p>264Vac, 50Hz, 10% Duty,</p>	<p>264Vac, 500Hz, 10% Duty, 12V@1~</p>	<p>264Vac, 500Hz, 10% Duty, 12V@1~</p>

<p>12V@18.29~45.73A ;12Vsb@0.1A, CH1:+12V current, CH2:+12V, CH3:PG</p>	<p>27.3A ;12Vsb@2A, CH1:+12V current, CH2:+12V, CH3:PG</p>	<p>28.44A ;12Vsb@0.1A, CH1:+12V current, CH2:+12V, CH3:PG</p>
		
<p>264Vac, 500Hz, 10% Duty, 12V@17.53~43.83A ;12Vsb@2A, CH1:+12V current, CH2:+12V, CH3:PG</p>	<p>264Vac, 500Hz, 10% Duty, 12V@18.29~45.73A ;12Vsb@0.1A, CH1:+12V current, CH2:+12V, CH3:PG</p>	<p>264Vac, 5kHz, 10% Duty, 12V@1~ 27.3A ;12Vsb@2A, CH1:+12V current, CH2:+12V, CH3:PG</p>
		
<p>264Vac, 5kHz, 10% Duty, 12V@1~ 28.44A ;12Vsb@0.1A, CH1:+12V current, CH2:+12V, CH3:PG</p>	<p>264Vac, 5kHz, 10% Duty, 12V@17.53~43.83A ;12Vsb@2A, CH1:+12V current, CH2:+12V, CH3:PG</p>	<p>264Vac, 5kHz, 10% Duty, 12V@18.29~45.73A ;12Vsb@0.1A, CH1:+12V current, CH2:+12V, CH3:PG</p>
		
<p>90Vac, 50Hz, 50% Duty, 12V@1~ 27.3A ;12Vsb@2A, CH1:+12V current, CH2:+12V, CH3:PG</p>	<p>90Vac, 50Hz, 50% Duty, 12V@1~ 28.44A ;12Vsb@0.1A, CH1:+12V current, CH2:+12V, CH3:PG</p>	<p>90Vac, 50Hz, 50% Duty, 12V@17.53~43.83A ;12Vsb@2A, CH1:+12V current, CH2:+12V, CH3:PG</p>
		



90Vac, 50Hz, 50% Duty,
12V@18.29~45.73A ;12Vsb@0.1A,
CH1:+12V current, CH2:+12V,
CH3:PG

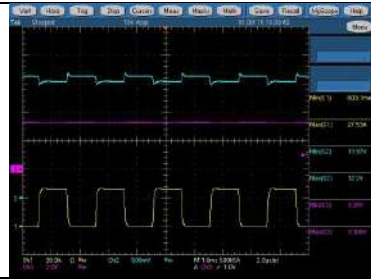

90Vac, 500Hz, 50% Duty, 12V@1~
27.3A ;12Vsb@2A,
CH1:+12V current, CH2:+12V,
CH3:PG

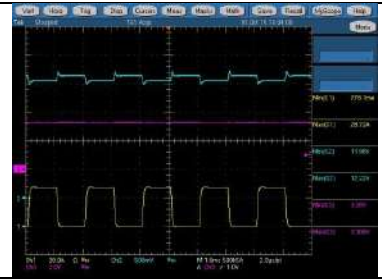

90Vac, 500Hz, 50% Duty, 12V@1~
28.44A ;12Vsb@0.1A,
CH1:+12V current, CH2:+12V,
CH3:PG



90Vac, 500Hz, 50% Duty,
12V@17.53~43.83A ;12Vsb@2A,
CH1:+12V current, CH2:+12V,
CH3:PG



90Vac, 500Hz, 50% Duty,
12V@18.29~45.73A ;12Vsb@0.1A,
CH1:+12V current, CH2:+12V,
CH3:PG

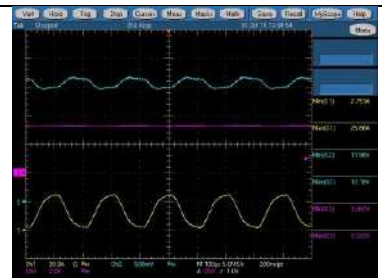

90Vac, 5kHz, 50% Duty, 12V@1~
27.3A ;12Vsb@2A,
CH1:+12V current, CH2:+12V,
CH3:PG

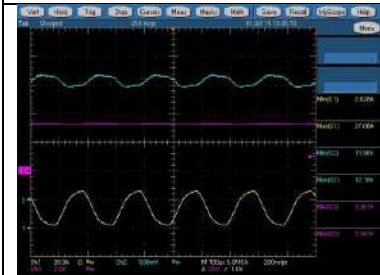

90Vac, 5kHz, 50% Duty, 12V@1~
28.44A ;12Vsb@0.1A,
CH1:+12V current, CH2:+12V,
CH3:PG

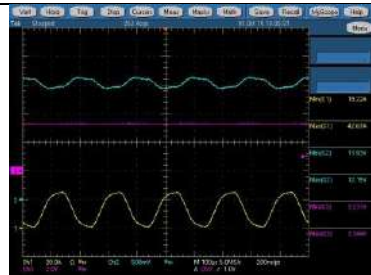

90Vac, 5kHz, 50% Duty,
12V@17.53~43.83A ;12Vsb@2A,
CH1:+12V current, CH2:+12V,
CH3:PG

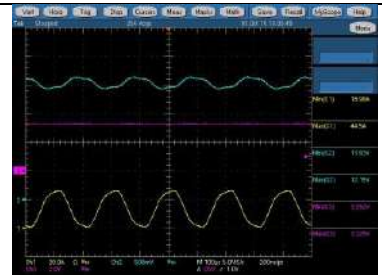

90Vac, 5kHz, 50% Duty,
12V@18.29~45.73A ;12Vsb@0.1A,
CH1:+12V current, CH2:+12V,
CH3:PG

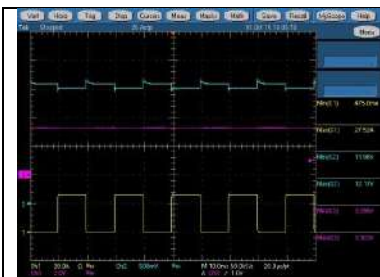

<p>264Vac, 50Hz, 50% Duty, 12V@1~27.3A ;12Vsb@2A, CH1:+12V current, CH2:+12V, CH3:PG</p>	<p>264Vac, 50Hz, 50% Duty, 12V@1~28.44A ;12Vsb@0.1A, CH1:+12V current, CH2:+12V, CH3:PG</p>	<p>264Vac, 50Hz, 50% Duty, 12V@17.53~43.83A ;12Vsb@2A, CH1:+12V current, CH2:+12V, CH3:PG</p>
		
<p>264Vac, 50Hz, 50% Duty, 12V@18.29~45.73A ;12Vsb@0.1A, CH1:+12V current, CH2:+12V, CH3:PG</p>	<p>264Vac, 500Hz, 50% Duty, 12V@1~27.3A ;12Vsb@2A, CH1:+12V current, CH2:+12V, CH3:PG</p>	<p>264Vac, 500Hz, 50% Duty, 12V@1~28.44A ;12Vsb@0.1A, CH1:+12V current, CH2:+12V, CH3:PG</p>
		
<p>264Vac, 500Hz, 50% Duty, 12V@17.53~43.83A ;12Vsb@2A, CH1:+12V current, CH2:+12V, CH3:PG</p>	<p>264Vac, 500Hz, 50% Duty, 12V@18.29~45.73A ;12Vsb@0.1A, CH1:+12V current, CH2:+12V, CH3:PG</p>	<p>264Vac, 5kHz, 50% Duty, 12V@1~27.3A ;12Vsb@2A, CH1:+12V current, CH2:+12V, CH3:PG</p>
		
<p>264Vac, 5kHz, 50% Duty, 12V@1~28.44A ;12Vsb@0.1A, CH1:+12V current, CH2:+12V, CH3:PG</p>	<p>264Vac, 5kHz, 50% Duty, 12V@17.53~43.83A ;12Vsb@2A, CH1:+12V current, CH2:+12V, CH3:PG</p>	<p>264Vac, 5kHz, 50% Duty, 12V@18.29~45.73A ;12Vsb@0.1A, CH1:+12V current, CH2:+12V, CH3:PG</p>

<p>90Vac, 50Hz, 90% Duty, 12V@1~ 27.3A ;12Vsb@2A, CH1:+12V current, CH2:+12V, CH3:PG</p>	<p>90Vac, 50Hz, 90% Duty, 12V@1~ 28.44A ;12Vsb@0.1A, CH1:+12V current, CH2:+12V, CH3:PG</p>	<p>90Vac, 50Hz, 90% Duty, 12V@17.53~43.83A ;12Vsb@2A, CH1:+12V current, CH2:+12V, CH3:PG</p>
<p>90Vac, 50Hz, 90% Duty, 12V@18.29~45.73A ;12Vsb@0.1A, CH1:+12V current, CH2:+12V, CH3:PG</p>	<p>90Vac, 500Hz, 90% Duty, 12V@1~ 27.3A ;12Vsb@2A, CH1:+12V current, CH2:+12V, CH3:PG</p>	<p>90Vac, 500Hz, 90% Duty, 12V@1~ 28.44A ;12Vsb@0.1A, CH1:+12V current, CH2:+12V, CH3:PG</p>
<p>90Vac, 500Hz, 90% Duty, 12V@17.53~43.83A ;12Vsb@2A, CH1:+12V current, CH2:+12V, CH3:PG</p>	<p>90Vac, 500Hz, 90% Duty, 12V@18.29~45.73A ;12Vsb@0.1A, CH1:+12V current, CH2:+12V, CH3:PG</p>	<p>90Vac, 5kHz, 90% Duty, 12V@1~ 27.3A ;12Vsb@2A, CH1:+12V current, CH2:+12V, CH3:PG</p>
<p>90Vac, 5kHz, 90% Duty, 12V@1~ 28.44A ;12Vsb@0.1A, CH1:+12V current, CH2:+12V, CH3:PG</p>	<p>90Vac, 5kHz, 90% Duty, 12V@17.53~43.83A ;12Vsb@2A, CH1:+12V current, CH2:+12V, CH3:PG</p>	<p>90Vac, 5kHz, 90% Duty, 12V@18.29~45.73A ;12Vsb@0.1A, CH1:+12V current, CH2:+12V, CH3:PG</p>

CH3:PG	CH3:PG	CH3:PG
--------	--------	--------

<p>264Vac, 50Hz, 90% Duty, 12V@1~27.3A ;12Vsb@2A, CH1:+12V current, CH2:+12V, CH3:PG</p>	<p>264Vac, 50Hz, 90% Duty, 12V@1~28.44A ;12Vsb@0.1A, CH1:+12V current, CH2:+12V, CH3:PG</p>	<p>264Vac, 50Hz, 90% Duty, 12V@17.53~43.83A ;12Vsb@2A, CH1:+12V current, CH2:+12V, CH3:PG</p>
<p>264Vac, 500Hz, 90% Duty, 12V@18.29~45.73A ;12Vsb@0.1A, CH1:+12V current, CH2:+12V, CH3:PG</p>	<p>264Vac, 500Hz, 90% Duty, 12V@1~27.3A ;12Vsb@2A, CH1:+12V current, CH2:+12V, CH3:PG</p>	<p>264Vac, 500Hz, 90% Duty, 12V@1~28.44A ;12Vsb@0.1A, CH1:+12V current, CH2:+12V, CH3:PG</p>
<p>264Vac, 500Hz, 90% Duty, 12V@17.53~43.83A ;12Vsb@2A, CH1:+12V current, CH2:+12V, CH3:PG</p>	<p>264Vac, 500Hz, 90% Duty, 12V@18.29~45.73A ;12Vsb@0.1A, CH1:+12V current, CH2:+12V, CH3:PG</p>	<p>264Vac, 5kHz, 90% Duty, 12V@1~27.3A ;12Vsb@2A, CH1:+12V current, CH2:+12V, CH3:PG</p>



264Vac, 5kHz, 90% Duty, 12V@1~
28.44A ;12Vsb@0.1A,
CH1:+12V current, CH2:+12V,
CH3:PG



264Vac, 5kHz, 90% Duty,
12V@17.53~43.83A ;12Vsb@2A,
CH1:+12V current, CH2:+12V,
CH3:PG





264Vac, 5kHz, 90% Duty,
12V@18.29~45.73A ;12Vsb@0.1A,
CH1:+12V current, CH2:+12V,
CH3:PG

12Vsb Dynamic									
Input		Period	Output		Test Limits		Test Results		Pass/Fail
Vin	Freq		12V	12Vsb	Min	Max	Min	Max	
90.00	63.00	50Hz/10%	44.73	0.1~1.1	11.400	12.600	11.925	12.003	PASS
			0.5	0.1~1.1	11.400	12.600	11.975	12.123	PASS
			42.83	2~3	11.400	12.600	11.808	11.881	PASS
			0.5	2~3	11.400	12.600	11.868	11.950	PASS
		OFF	2~3	11.400	12.600	11.701	11.854	PASS	
		500Hz/10%	44.73	0.1~1.1	11.400	12.600	11.918	12.008	PASS
			0.5	0.1~1.1	11.400	12.600	11.978	12.115	PASS
			42.83	2~3	11.400	12.600	11.797	11.887	PASS
			0.5	2~3	11.400	12.600	11.863	11.953	PASS
		OFF	2~3	11.400	12.600	11.649	11.868	PASS	
		5kHz/10%	44.73	0.1~1.1	11.400	12.600	11.917	12.012	PASS
			0.5	0.1~1.1	11.400	12.600	12.004	12.096	PASS
42.83	2~3		11.400	12.600	11.794	11.887	PASS		
0.5	2~3		11.400	12.600	11.862	11.955	PASS		
OFF	2~3	11.400	12.600	11.670	11.844	PASS			
264.00	47.00	50Hz/10%	44.73	0.1~1.1	11.400	12.600	11.927	12.004	PASS
			0.5	0.1~1.1	11.400	12.600	11.975	12.123	PASS
			42.83	2~3	11.400	12.600	11.806	11.882	PASS
			0.5	2~3	11.400	12.600	11.868	11.950	PASS
		OFF	2~3	11.400	12.600	11.677	11.848	PASS	
		500Hz/10%	44.73	0.1~1.1	11.400	12.600	11.920	12.009	PASS
			0.5	0.1~1.1	11.400	12.600	11.977	12.115	PASS
			42.83	2~3	11.400	12.600	11.797	11.885	PASS
			0.5	2~3	11.400	12.600	11.863	11.953	PASS
		OFF	2~3	11.400	12.600	11.663	11.868	PASS	
		5kHz/10%	44.73	0.1~1.1	11.400	12.600	11.918	12.013	PASS
			0.5	0.1~1.1	11.400	12.600	12.003	12.096	PASS
42.83	2~3		11.400	12.600	11.795	11.889	PASS		
0.5	2~3		11.400	12.600	11.862	11.955	PASS		
OFF	2~3	11.400	12.600	11.667	11.843	PASS			
90.00	63.00	50Hz/50%	44.73	0.1~1.1	11.400	12.600	11.927	12.005	PASS
			0.5	0.1~1.1	11.400	12.600	11.976	12.122	PASS
			42.83	2~3	11.400	12.600	11.809	11.885	PASS
			0.5	2~3	11.400	12.600	11.867	11.950	PASS
		OFF	2~3	11.400	12.600	11.689	11.866	PASS	
		500Hz/50%	44.73	0.1~1.1	11.400	12.600	11.919	12.009	PASS
			0.5	0.1~1.1	11.400	12.600	11.962	12.131	PASS
			42.83	2~3	11.400	12.600	11.803	11.889	PASS
			0.5	2~3	11.400	12.600	11.863	11.953	PASS
		OFF	2~3	11.400	12.600	11.678	11.876	PASS	
		5kHz/50%	44.73	0.1~1.1	11.400	12.600	11.917	12.012	PASS
			0.5	0.1~1.1	11.400	12.600	12.001	12.100	PASS
42.83	2~3		11.400	12.600	11.799	11.894	PASS		
0.5	2~3		11.400	12.600	11.862	11.956	PASS		
OFF	2~3	11.400	12.600	11.679	11.886	PASS			
264.00	47.00	50Hz/50%	44.73	0.1~1.1	11.400	12.600	11.926	12.004	PASS
			0.5	0.1~1.1	11.400	12.600	11.976	12.122	PASS
			42.83	2~3	11.400	12.600	11.809	11.885	PASS

			0.5	2~3	11.400	12.600	11.866	11.950	PASS
			OFF	2~3	11.400	12.600	11.698	11.879	PASS
		500Hz/50%	44.73	0.1~1.1	11.400	12.600	11.920	12.009	PASS
			0.5	0.1~1.1	11.400	12.600	11.961	12.130	PASS
			42.83	2~3	11.400	12.600	11.800	11.890	PASS
			0.5	2~3	11.400	12.600	11.864	11.953	PASS
			OFF	2~3	11.400	12.600	11.673	11.878	PASS
			44.73	0.1~1.1	11.400	12.600	11.917	12.002	PASS
		5kHz/50%	0.5	0.1~1.1	11.400	12.600	12.003	12.083	PASS
			42.83	2~3	11.400	12.600	11.806	11.893	PASS
			0.5	2~3	11.400	12.600	11.867	11.949	PASS
			OFF	2~3	11.400	12.600	11.712	11.901	PASS
			44.73	0.1~1.1	11.400	12.600	11.928	12.005	PASS
			0.5	0.1~1.1	11.400	12.600	11.975	12.123	PASS
90.00	63.00	50Hz/90%	42.83	2~3	11.400	12.600	11.815	11.887	PASS
			0.5	2~3	11.400	12.600	11.868	11.950	PASS
			OFF	2~3	11.400	12.600	11.714	11.883	PASS
			44.73	0.1~1.1	11.400	12.600	11.921	12.010	PASS
			0.5	0.1~1.1	11.400	12.600	11.991	12.122	PASS
		500Hz/90%	42.83	2~3	11.400	12.600	11.806	11.893	PASS
			0.5	2~3	11.400	12.600	11.865	11.953	PASS
			OFF	2~3	11.400	12.600	11.682	11.891	PASS
			44.73	0.1~1.1	11.400	12.600	11.919	12.002	PASS
		5kHz/90%	0.5	0.1~1.1	11.400	12.600	12.005	12.084	PASS
			42.83	2~3	11.400	12.600	11.805	11.893	PASS
			0.5	2~3	11.400	12.600	11.868	11.950	PASS
			OFF	2~3	11.400	12.600	11.728	11.895	PASS
			44.73	0.1~1.1	11.400	12.600	11.928	12.005	PASS
264.00	47.00	50Hz/90%	0.5	0.1~1.1	11.400	12.600	11.975	12.123	PASS
			42.83	2~3	11.400	12.600	11.815	11.888	PASS
			0.5	2~3	11.400	12.600	11.869	11.950	PASS
			OFF	2~3	11.400	12.600	11.702	11.881	PASS
			44.73	0.1~1.1	11.400	12.600	11.920	12.010	PASS
		500Hz/90%	0.5	0.1~1.1	11.400	12.600	11.992	12.123	PASS
			42.83	2~3	11.400	12.600	11.804	11.894	PASS
			0.5	2~3	11.400	12.600	11.865	11.953	PASS
			OFF	2~3	11.400	12.600	11.686	11.889	PASS
		5kHz/90%	44.73	0.1~1.1	11.400	12.600	11.917	12.001	PASS
			0.5	0.1~1.1	11.400	12.600	12.005	12.084	PASS
			42.83	2~3	11.400	12.600	11.806	11.893	PASS
			0.5	2~3	11.400	12.600	11.868	11.949	PASS
			OFF	2~3	11.400	12.600	11.727	11.894	PASS

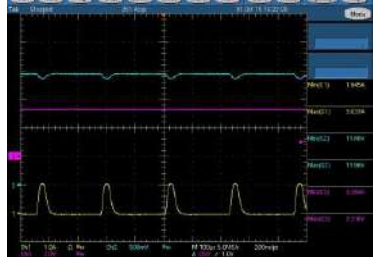
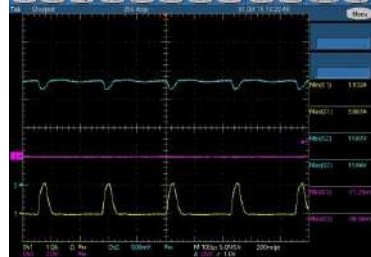
<p>90Vac, 50Hz, 10% Duty, 12Vsb@0.1~ 1.1A;12V@44.73A, CH1:+12Vsb current, CH2:+12Vsb, CH3:PG</p>	<p>90Vac, 50Hz, 10% Duty, 12Vsb@0.1~ 1.1A;12V@0.5A, CH1:+12Vsb current, CH2:+12Vsb, CH3:PG</p>	<p>90Vac, 50Hz, 10% Duty, 12Vsb@2~ 3A;12V@42.83A, CH1:+12Vsb current, CH2:+12Vsb, CH3:PG</p>
<p>90Vac, 50Hz, 10% Duty, 12Vsb@2~ 3A;12V@0.5A, CH1:+12Vsb current, CH2:+12Vsb, CH3:PG</p>	<p>90Vac, 50Hz, 10% Duty, 12Vsb@2~ 3A;12V@OFF, CH1:+12Vsb current, CH2:+12Vsb, CH3:PG</p>	<p>90Vac, 500Hz, 10% Duty, 12Vsb@0.1~ 1.1A;12V@44.73A, CH1:+12Vsb current, CH2:+12Vsb, CH3:PG</p>
<p>90Vac, 500Hz, 10% Duty, 12Vsb@0.1~ 1.1A;12V@0.5A, CH1:+12Vsb current, CH2:+12Vsb, CH3:PG</p>	<p>90Vac, 500Hz, 10% Duty, 12Vsb@2~ 3A;12V@42.83A, CH1:+12Vsb current, CH2:+12Vsb, CH3:PG</p>	<p>90Vac, 500Hz, 10% Duty, 12Vsb@2~ 3A;12V@0.5A, CH1:+12Vsb current, CH2:+12Vsb, CH3:PG</p>
<p>90Vac, 500Hz, 10% Duty, 12Vsb@2~ 3A;12V@OFF, CH1:+12Vsb current, CH2:+12Vsb,</p>	<p>90Vac, 5kHz, 10% Duty, 12Vsb@0.1~ 1.1A;12V@44.73A, CH1:+12Vsb current, CH2:+12Vsb,</p>	<p>90Vac, 5kHz, 10% Duty, 12Vsb@0.1~ 1.1A;12V@0.5A, CH1:+12Vsb current, CH2:+12Vsb,</p>

CH3:PG	CH3:PG	CH3:PG
		
<p>90Vac, 5kHz, 10% Duty, 12Vsb@2~3A;12V@42.83A, CH1:+12Vsb current, CH2:+12Vsb, CH3:PG</p>	<p>90Vac, 5kHz, 10% Duty, 12Vsb@2~3A;12V@0.5A, CH1:+12Vsb current, CH2:+12Vsb, CH3:PG</p>	<p>90Vac, 5kHz, 10% Duty, 12Vsb@2~3A;12V@OFF, CH1:+12Vsb current, CH2:+12Vsb, CH3:PG</p>

		
<p>264Vac, 50Hz, 10% Duty, 12Vsb@0.1~1.1A;12V@44.73A, CH1:+12Vsb current, CH2:+12Vsb, CH3:PG</p>	<p>264Vac, 50Hz, 10% Duty, 12Vsb@0.1~1.1A;12V@0.5A, CH1:+12Vsb current, CH2:+12Vsb, CH3:PG</p>	<p>264Vac, 50Hz, 10% Duty, 12Vsb@2~3A;12V@42.83A, CH1:+12Vsb current, CH2:+12Vsb, CH3:PG</p>
		
<p>264Vac, 50Hz, 10% Duty, 12Vsb@2~3A;12V@0.5A, CH1:+12Vsb current, CH2:+12Vsb, CH3:PG</p>	<p>264Vac, 50Hz, 10% Duty, 12Vsb@2~3A;12V@OFF, CH1:+12Vsb current, CH2:+12Vsb, CH3:PG</p>	<p>264Vac, 500Hz, 10% Duty, 12Vsb@0.1~1.1A;12V@44.73A, CH1:+12Vsb current, CH2:+12Vsb, CH3:PG</p>

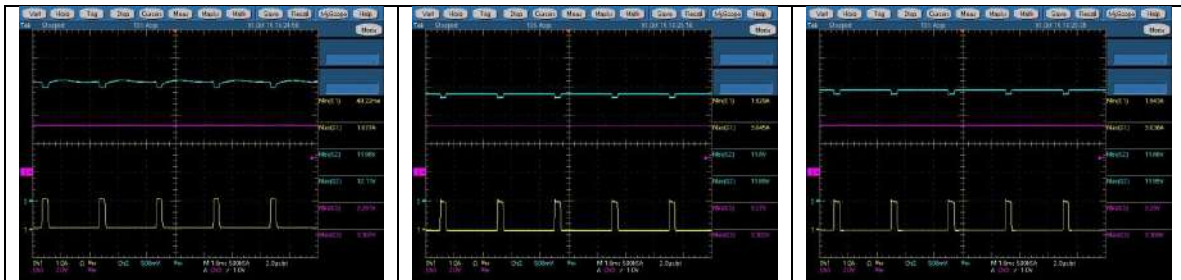

264Vac, 500Hz, 10% Duty,
12Vsb@0.1~ 1.1A;12V@0.5A,
CH1:+12Vsb current, CH2:+12Vsb,
CH3:PG

264Vac, 500Hz, 10% Duty,
12Vsb@2~ 3A;12V@42.83A,
CH1:+12Vsb current, CH2:+12Vsb,
CH3:PG

264Vac, 500Hz, 10% Duty,
12Vsb@2~ 3A;12V@0.5A,
CH1:+12Vsb current, CH2:+12Vsb,
CH3:PG

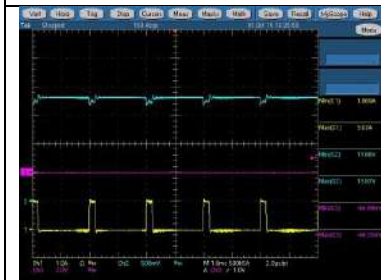

264Vac, 500Hz, 10% Duty,
12Vsb@2~ 3A;12V@OFF,
CH1:+12Vsb current, CH2:+12Vsb,
CH3:PG



264Vac, 5kHz, 10% Duty,
12Vsb@0.1~ 1.1A;12V@44.73A,
CH1:+12Vsb current, CH2:+12Vsb,
CH3:PG

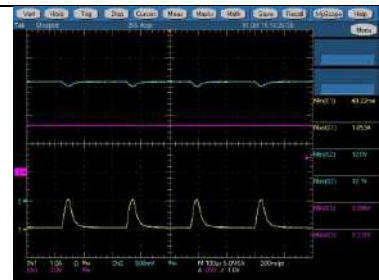

264Vac, 5kHz, 10% Duty,
12Vsb@0.1~ 1.1A;12V@0.5A,
CH1:+12Vsb current, CH2:+12Vsb,
CH3:PG

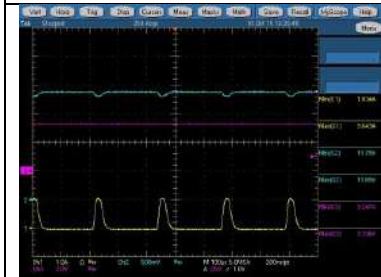

264Vac, 5kHz, 10% Duty, 12Vsb@2~
3A;12V@42.83A,
CH1:+12Vsb current, CH2:+12Vsb,
CH3:PG

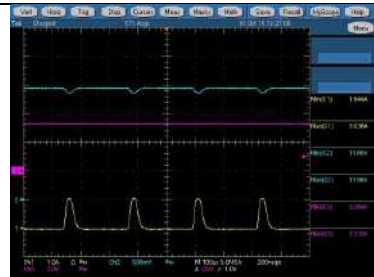

264Vac, 5kHz, 10% Duty, 12Vsb@2~
3A;12V@0.5A,
CH1:+12Vsb current, CH2:+12Vsb,
CH3:PG

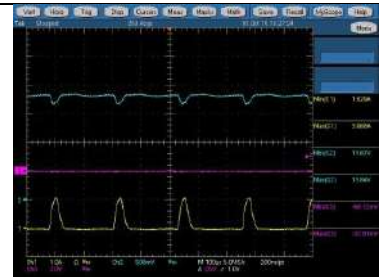

264Vac, 5kHz, 10% Duty, 12Vsb@2~
3A;12V@OFF,
CH1:+12Vsb current, CH2:+12Vsb,
CH3:PG

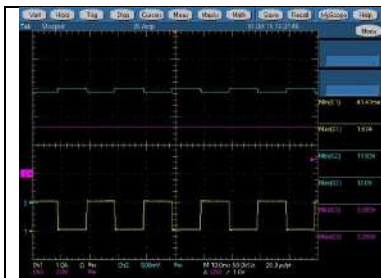



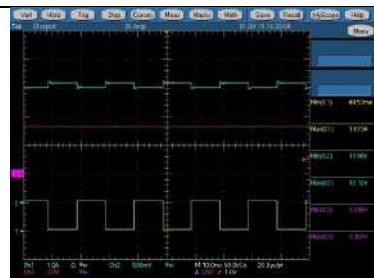



90Vac, 50Hz, 50% Duty,
12Vsb@0.1~ 1.1A;12V@44.73A,

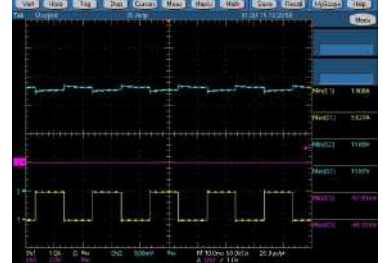
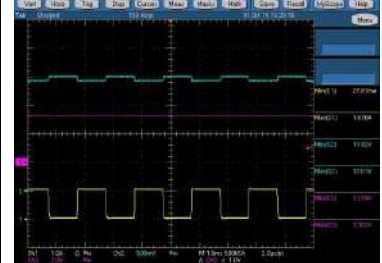

90Vac, 50Hz, 50% Duty,
12Vsb@0.1~ 1.1A;12V@0.5A,

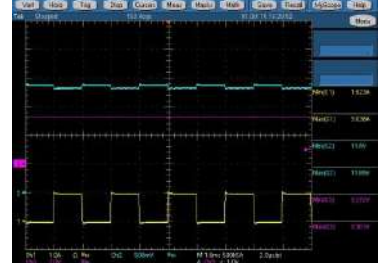

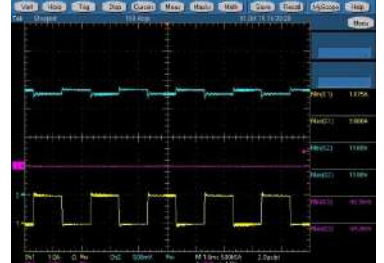
90Vac, 50Hz, 50% Duty, 12Vsb@2~
3A;12V@42.83A,

<p>CH1:+12Vsb current, CH2:+12Vsb, CH3:PG</p>	<p>CH1:+12Vsb current, CH2:+12Vsb, CH3:PG</p>	<p>CH1:+12Vsb current, CH2:+12Vsb, CH3:PG</p>
		
<p>90Vac, 50Hz, 50% Duty, 12Vsb@2~ 3A;12V@0.5A, CH1:+12Vsb current, CH2:+12Vsb, CH3:PG</p>	<p>90Vac, 50Hz, 50% Duty, 12Vsb@2~ 3A;12V@OFF, CH1:+12Vsb current, CH2:+12Vsb, CH3:PG</p>	<p>90Vac, 500Hz, 50% Duty, 12Vsb@0.1~ 1.1A;12V@44.73A, CH1:+12Vsb current, CH2:+12Vsb, CH3:PG</p>
		
<p>90Vac, 500Hz, 50% Duty, 12Vsb@0.1~ 1.1A;12V@0.5A, CH1:+12Vsb current, CH2:+12Vsb, CH3:PG</p>	<p>90Vac, 500Hz, 50% Duty, 12Vsb@2~ 3A;12V@42.83A, CH1:+12Vsb current, CH2:+12Vsb, CH3:PG</p>	<p>90Vac, 500Hz, 50% Duty, 12Vsb@2~ 3A;12V@0.5A, CH1:+12Vsb current, CH2:+12Vsb, CH3:PG</p>
		
<p>90Vac, 500Hz, 50% Duty, 12Vsb@2~ 3A;12V@OFF, CH1:+12Vsb current, CH2:+12Vsb, CH3:PG</p>	<p>90Vac, 5kHz, 50% Duty, 12Vsb@0.1~ 1.1A;12V@44.73A, CH1:+12Vsb current, CH2:+12Vsb, CH3:PG</p>	<p>90Vac, 5kHz, 50% Duty, 12Vsb@0.1~ 1.1A;12V@0.5A, CH1:+12Vsb current, CH2:+12Vsb, CH3:PG</p>

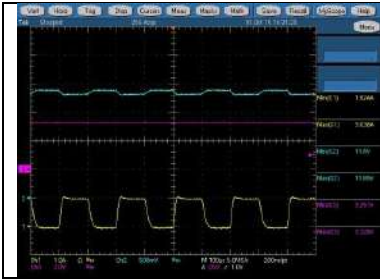

90Vac, 5kHz, 50% Duty, 12Vsb@2~3A;12V@42.83A,
CH1:+12Vsb current, CH2:+12Vsb,
CH3:PG

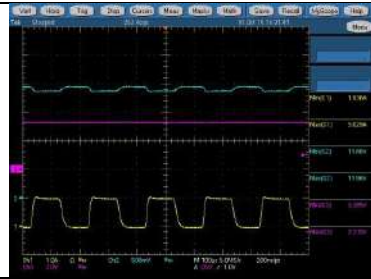

90Vac, 5kHz, 50% Duty, 12Vsb@2~3A;12V@0.5A,
CH1:+12Vsb current, CH2:+12Vsb,
CH3:PG

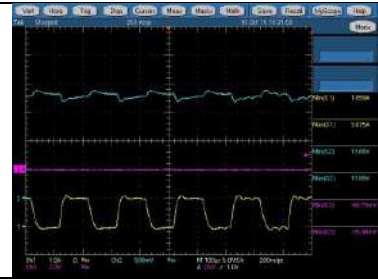

90Vac, 5kHz, 50% Duty, 12Vsb@2~3A;12V@OFF,
CH1:+12Vsb current, CH2:+12Vsb,
CH3:PG

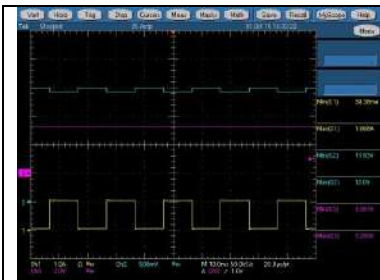

264Vac, 50Hz, 50% Duty,
12Vsb@0.1~1.1A;12V@44.73A,
CH1:+12Vsb current, CH2:+12Vsb,
CH3:PG



264Vac, 50Hz, 50% Duty,
12Vsb@0.1~1.1A;12V@0.5A,
CH1:+12Vsb current, CH2:+12Vsb,
CH3:PG

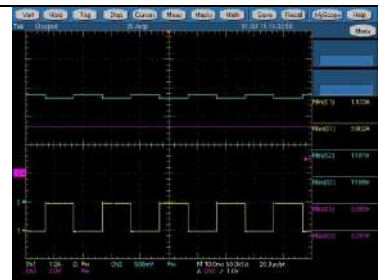

264Vac, 50Hz, 50% Duty, 12Vsb@2~3A;12V@42.83A,
CH1:+12Vsb current, CH2:+12Vsb,
CH3:PG

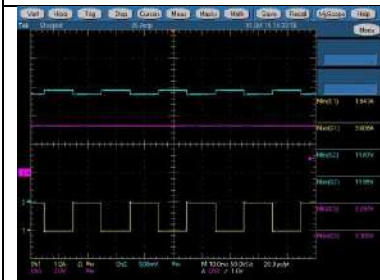

264Vac, 50Hz, 50% Duty, 12Vsb@2~3A;12V@0.5A,
CH1:+12Vsb current, CH2:+12Vsb,
CH3:PG

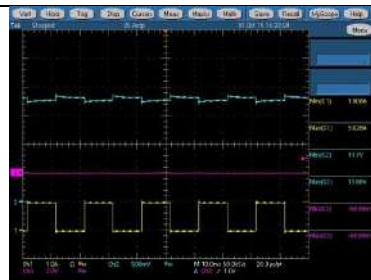



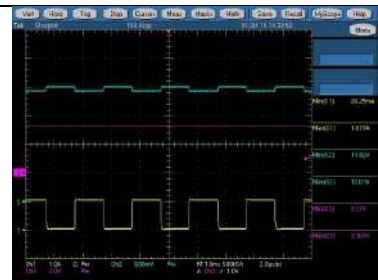









264Vac, 50Hz, 50% Duty, 12Vsb@2~3A;12V@OFF,
CH1:+12Vsb current, CH2:+12Vsb,
CH3:PG



264Vac, 500Hz, 50% Duty,
12Vsb@0.1~1.1A;12V@44.73A,
CH1:+12Vsb current, CH2:+12Vsb,
CH3:PG

<p>264Vac, 500Hz, 50% Duty, 12Vsb@0.1~ 1.1A;12V@0.5A, CH1:+12Vsb current, CH2:+12Vsb, CH3:PG</p>	<p>264Vac, 500Hz, 50% Duty, 12Vsb@2~ 3A;12V@42.83A, CH1:+12Vsb current, CH2:+12Vsb, CH3:PG</p>	<p>264Vac, 500Hz, 50% Duty, 12Vsb@2~ 3A;12V@0.5A, CH1:+12Vsb current, CH2:+12Vsb, CH3:PG</p>
<p>264Vac, 500Hz, 50% Duty, 12Vsb@2~ 3A;12V@OFF, CH1:+12Vsb current, CH2:+12Vsb, CH3:PG</p>	<p>264Vac, 5kHz, 50% Duty, 12Vsb@0.1~ 1.1A;12V@44.73A, CH1:+12Vsb current, CH2:+12Vsb, CH3:PG</p>	<p>264Vac, 5kHz, 50% Duty, 12Vsb@0.1~ 1.1A;12V@0.5A, CH1:+12Vsb current, CH2:+12Vsb, CH3:PG</p>
<p>264Vac, 5kHz, 50% Duty, 12Vsb@2~ 3A;12V@42.83A, CH1:+12Vsb current, CH2:+12Vsb, CH3:PG</p>	<p>264Vac, 5kHz, 50% Duty, 12Vsb@2~ 3A;12V@0.5A, CH1:+12Vsb current, CH2:+12Vsb, CH3:PG</p>	<p>264Vac, 5kHz, 50% Duty, 12Vsb@2~ 3A;12V@OFF, CH1:+12Vsb current, CH2:+12Vsb, CH3:PG</p>

		
<p>90Vac, 50Hz, 90% Duty, 12Vsb@0.1~1.1A;12V@44.73A, CH1:+12Vsb current, CH2:+12Vsb, CH3:PG</p>	<p>90Vac, 50Hz, 90% Duty, 12Vsb@0.1~1.1A;12V@0.5A, CH1:+12Vsb current, CH2:+12Vsb, CH3:PG</p>	<p>90Vac, 50Hz, 90% Duty, 12Vsb@2~ 3A;12V@42.83A, CH1:+12Vsb current, CH2:+12Vsb, CH3:PG</p>
		
<p>90Vac, 50Hz, 90% Duty, 12Vsb@2~ 3A;12V@0.5A, CH1:+12Vsb current, CH2:+12Vsb, CH3:PG</p>	<p>90Vac, 50Hz, 90% Duty, 12Vsb@2~ 3A;12V@OFF, CH1:+12Vsb current, CH2:+12Vsb, CH3:PG</p>	<p>90Vac, 500Hz, 90% Duty, 12Vsb@0.1~1.1A;12V@44.73A, CH1:+12Vsb current, CH2:+12Vsb, CH3:PG</p>
		
<p>90Vac, 500Hz, 90% Duty, 12Vsb@0.1~1.1A;12V@0.5A, CH1:+12Vsb current, CH2:+12Vsb, CH3:PG</p>	<p>90Vac, 500Hz, 90% Duty, 12Vsb@2~ 3A;12V@42.83A, CH1:+12Vsb current, CH2:+12Vsb, CH3:PG</p>	<p>90Vac, 500Hz, 90% Duty, 12Vsb@2~ 3A;12V@0.5A, CH1:+12Vsb current, CH2:+12Vsb, CH3:PG</p>
		
<p>90Vac, 500Hz, 90% Duty, 12Vsb@2~ 3A;12V@OFF,</p>	<p>90Vac, 5kHz, 90% Duty, 12Vsb@0.1~ 1.1A;12V@44.73A,</p>	<p>90Vac, 5kHz, 90% Duty, 12Vsb@0.1~ 1.1A;12V@0.5A,</p>

<p>CH1:+12Vsb current, CH2:+12Vsb, CH3:PG</p>	<p>CH1:+12Vsb current, CH2:+12Vsb, CH3:PG</p>	<p>CH1:+12Vsb current, CH2:+12Vsb, CH3:PG</p>
<p>90Vac, 5kHz, 90% Duty, 12Vsb@2~ 3A;12V@42.83A, CH1:+12Vsb current, CH2:+12Vsb, CH3:PG</p>	<p>90Vac, 5kHz, 90% Duty, 12Vsb@2~ 3A;12V@0.5A, CH1:+12Vsb current, CH2:+12Vsb, CH3:PG</p>	<p>90Vac, 5kHz, 90% Duty, 12Vsb@2~ 3A;12V@OFF, CH1:+12Vsb current, CH2:+12Vsb, CH3:PG</p>

<p>264Vac, 50Hz, 90% Duty, 12Vsb@0.1~ 1.1A;12V@44.73A, CH1:+12Vsb current, CH2:+12Vsb, CH3:PG</p>	<p>264Vac, 50Hz, 90% Duty, 12Vsb@0.1~ 1.1A;12V@0.5A, CH1:+12Vsb current, CH2:+12Vsb, CH3:PG</p>	<p>264Vac, 50Hz, 90% Duty, 12Vsb@2~ 3A;12V@42.83A, CH1:+12Vsb current, CH2:+12Vsb, CH3:PG</p>
<p>264Vac, 50Hz, 90% Duty, 12Vsb@2~ 3A;12V@0.5A, CH1:+12Vsb current, CH2:+12Vsb, CH3:PG</p>	<p>264Vac, 50Hz, 90% Duty, 12Vsb@2~ 3A;12V@OFF, CH1:+12Vsb current, CH2:+12Vsb, CH3:PG</p>	<p>264Vac, 500Hz, 90% Duty, 12Vsb@0.1~ 1.1A;12V@44.73A, CH1:+12Vsb current, CH2:+12Vsb, CH3:PG</p>

<p>264Vac, 500Hz, 90% Duty, 12Vsb@0.1~1.1A;12V@0.5A, CH1:+12Vsb current, CH2:+12Vsb, CH3:PG</p>	<p>264Vac, 500Hz, 90% Duty, 12Vsb@2~3A;12V@42.83A, CH1:+12Vsb current, CH2:+12Vsb, CH3:PG</p>	<p>264Vac, 500Hz, 90% Duty, 12Vsb@2~3A;12V@0.5A, CH1:+12Vsb current, CH2:+12Vsb, CH3:PG</p>
<p>264Vac, 500Hz, 90% Duty, 12Vsb@2~3A;12V@OFF, CH1:+12Vsb current, CH2:+12Vsb, CH3:PG</p>	<p>264Vac, 5kHz, 90% Duty, 12Vsb@0.1~1.1A;12V@44.73A, CH1:+12Vsb current, CH2:+12Vsb, CH3:PG</p>	<p>264Vac, 5kHz, 90% Duty, 12Vsb@0.1~1.1A;12V@0.5A, CH1:+12Vsb current, CH2:+12Vsb, CH3:PG</p>
<p>264Vac, 5kHz, 90% Duty, 12Vsb@2~3A;12V@42.83A, CH1:+12Vsb current, CH2:+12Vsb, CH3:PG</p>	<p>264Vac, 5kHz, 90% Duty, 12Vsb@2~3A;12V@0.5A, CH1:+12Vsb current, CH2:+12Vsb, CH3:PG</p>	<p>264Vac, 5kHz, 90% Duty, 12Vsb@2~3A;12V@OFF, CH1:+12Vsb current, CH2:+12Vsb, CH3:PG</p>

Line Voltage Regulation								
Input		Output		Test Limits		Test Results	Pass/Fail	Remarks
Vin	Freq	Volt	Load	Min	Max			
90.00	47.00	+12V	43.830	11.400	12.600	11.969	PASS	90Vac/47Hz Max Load
		+12Vsb	2.000	11.400	12.600	11.849		
90.00	47.00	+12V	0.500	11.400	12.600	12.102	PASS	90Vac/47Hz Min Load
		+12Vsb	0.100	11.400	12.600	12.101		
90.00	47.00	+12V	8.766	11.400	12.600	12.085	PASS	90Vac/47Hz 20% Load
		+12Vsb	0.400	11.400	12.600	12.063		
90.00	47.00	+12V	21.915	11.400	12.600	12.045	PASS	90Vac/47Hz 50% Load
		+12Vsb	1.000	11.400	12.600	11.980		
90.00	47.00	+12V	32.873	11.400	12.600	12.007	PASS	90Vac/47Hz 75% Load
		+12Vsb	1.500	11.400	12.600	11.910		
90.00	47.00	+12V	45.830	11.400	12.600	11.967	PASS	90Vac/47Hz Cross1 Load
		+12Vsb	0.100	11.400	12.600	11.999		
90.00	47.00	+12V	0.500	11.400	12.600	12.097	PASS	90Vac/47Hz Cross2 Load
		+12Vsb	3.000	11.400	12.600	11.855		
264.00	63.00	+12V	43.830	11.400	12.600	11.969	PASS	264Vac/63Hz Max Load
		+12Vsb	2.000	11.400	12.600	11.851		
264.00	63.00	+12V	0.500	11.400	12.600	12.102	PASS	264Vac/63Hz Min Load
		+12Vsb	0.100	11.400	12.600	12.101		
264.00	63.00	+12V	8.766	11.400	12.600	12.085	PASS	264Vac/63Hz 20% Load
		+12Vsb	0.400	11.400	12.600	12.063		
264.00	63.00	+12V	21.915	11.400	12.600	12.042	PASS	264Vac/63Hz 50% Load
		+12Vsb	1.000	11.400	12.600	11.979		
264.00	63.00	+12V	32.873	11.400	12.600	12.007	PASS	264Vac/63Hz 75% Load
		+12Vsb	1.500	11.400	12.600	11.910		
264.00	63.00	+12V	45.830	11.400	12.600	11.967	PASS	264Vac/63Hz Cross1 Load
		+12Vsb	0.100	11.400	12.600	11.999		
264.00	63.00	+12V	0.500	11.400	12.600	12.097	PASS	264Vac/63Hz Cross2 Load
		+12Vsb	3.000	11.400	12.600	11.855		
90.00	47.00	+12V	0.500	*	*	0.222	PASS	90Vac/47Hz SB Mode @3A
		+12Vsb	3.000	11.400	12.600	11.759		
264.00	63.00	+12V	0.500	*	*	0.049	PASS	264Vac/63Hz SB Mode @3A
		+12Vsb	3.000	11.400	12.600	11.762		

Ripple									
Input		Load		Test Limits		Test Results		Pass/Fail	Remarks
Vin	Freq	12V	12Vsb	12V	12Vsb	12V	12Vsb		
90.00	47.00	43.83	2.00	120.00	120.00	43.56	29.76	PASS	90Vac/47Hz Max Load
		0.50	0.10	120.00	120.00	21.60	25.20	PASS	90Vac/47Hz Min Load
		45.83	0.10	120.00	120.00	42.24	37.12	PASS	90Vac/47Hz Cross Load 1
		0.50	3.00	120.00	120.00	22.68	18.72	PASS	90Vac/47Hz Cross Load 2
264.00	63.00	43.83	2.00	120.00	120.00	43.56	29.76	PASS	264Vac/63Hz Max Load
		0.50	0.10	120.00	120.00	22.68	26.88	PASS	264Vac/63Hz Min Load
		45.83	0.10	120.00	120.00	42.24	33.64	PASS	264Vac/63Hz Cross Load 1
		0.50	3.00	120.00	120.00	23.52	19.44	PASS	264Vac/63Hz Cross Load 2
90.00	47.00	0.50	3.00	*	120.00	0.00	36.72	PASS	90Vac/47Hz Standby Mode
264.00	63.00	0.50	3.00	*	120.00	0.00	18.00	PASS	264Vac/63Hz Standby Mode

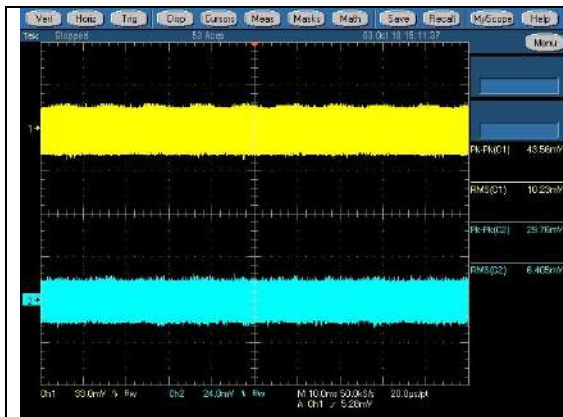

90Vac/47Hz Max Load
CH1: +12V, CH2: +12Vsb

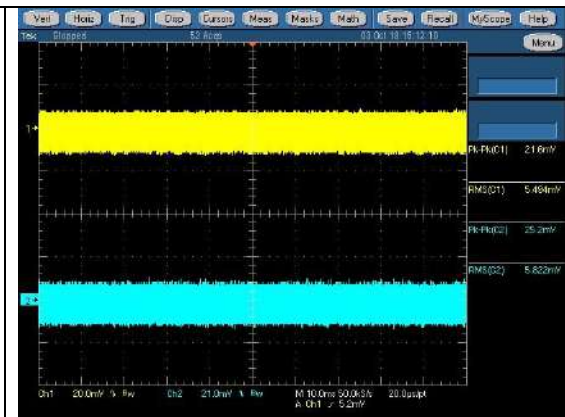

90Vac/47Hz Min Load
CH1: +12V, CH2: +12Vsb

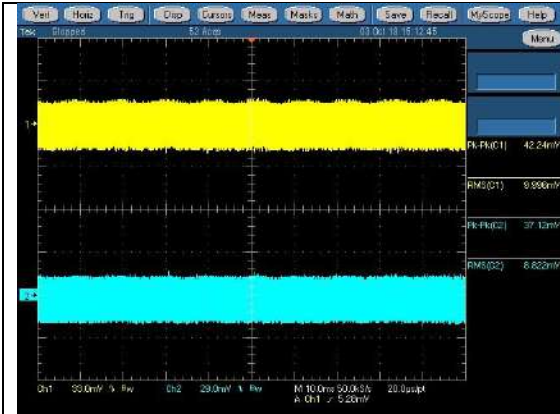

90Vac/47Hz Cross Load 1
CH1: +12V, CH2: +12Vsb

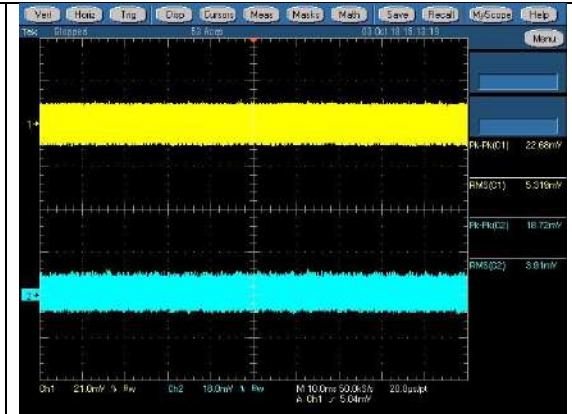

90Vac/47Hz Cross Load 2
CH1: +12V, CH2: +12Vsb

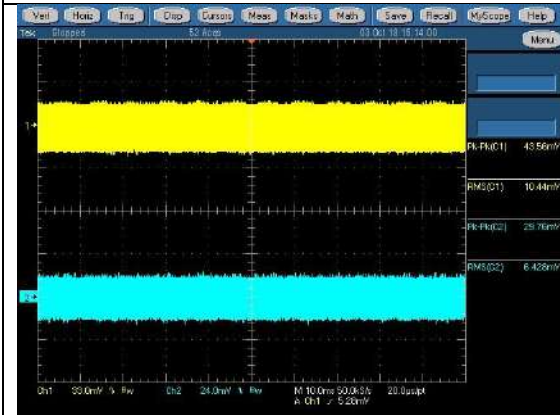

264Vac/63Hz Max Load
CH1: +12V, CH2: +12Vsb

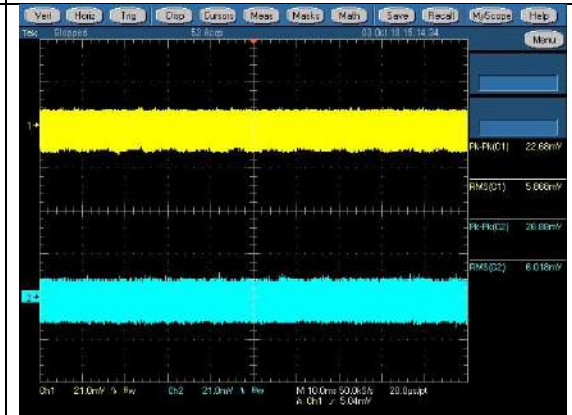

264Vac/63Hz Min Load
CH1: +12V, CH2: +12Vsb

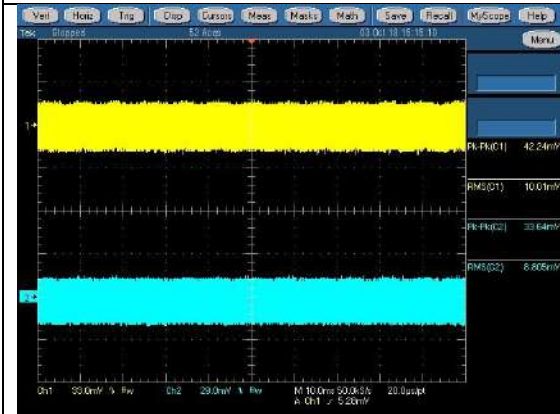

264Vac/63Hz Cross Load 1
CH1: +12V, CH2: +12Vsb

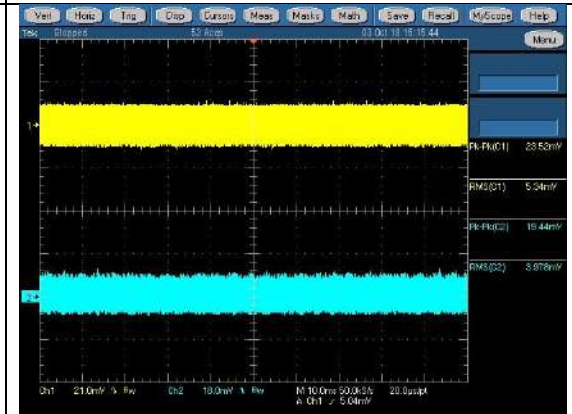

264Vac/63Hz Cross Load 2
CH1: +12V, CH2: +12Vsb

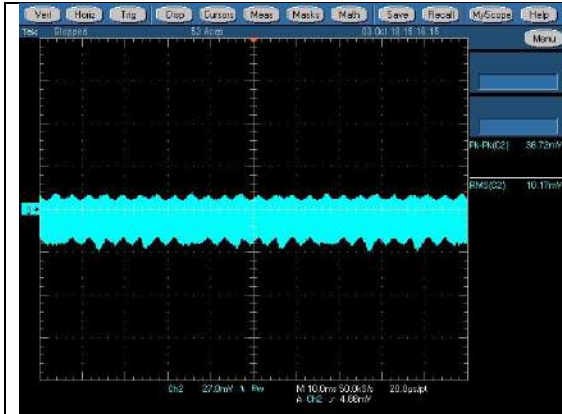

90Vac/47Hz Standby Mode
CH2: +12Vsb

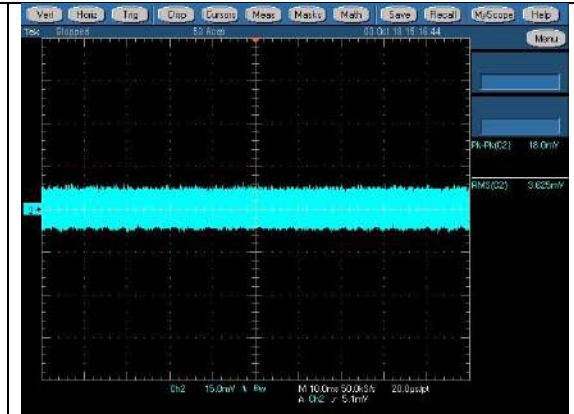

264Vac/63Hz Standby Mode
CH2: +12Vsb

T ac_on_delay								
Input		Output		Test Limits		Test Results	Pass / Fail	Remarks
Vin	Freq	Volt	Load	Min	Max			
90.00	47.00	+12V	43.830	*	1500.000	54.400	PASS	90V +12Vsb max CH1:+12Vsb, CH4:Vin
		+12Vsb	2.000					
90.00	47.00	+12V	0.500	*	1500.000	252.200	PASS	90V +12Vsb min CH1:+12Vsb, CH4:Vin
		+12Vsb	0.100					
264.00	63.00	+12V	43.830	*	1500.000	189.840	PASS	264V +12Vsb max CH1:+12Vsb, CH4:Vin
		+12Vsb	2.000					
264.00	63.00	+12V	0.500	*	1500.000	265.600	PASS	264V +12Vsb min CH1:+12Vsb, CH4:Vin
		+12Vsb	0.100					
90.00	47.00	+12V	43.830	*	3000.000	871.600	PASS	90V +12V max CH1:+12V, CH4:Vin
		+12Vsb	2.000					
90.00	47.00	+12V	0.500	*	3000.000	730.000	PASS	90V +12V min CH1:+12V, CH4:Vin
		+12Vsb	0.100					
264.00	63.00	+12V	43.830	*	3000.000	700.000	PASS	264V +12V max CH1:+12V, CH4:Vin
		+12Vsb	2.000					
264.00	63.00	+12V	0.500	*	3000.000	625.600	PASS	264V +12V min CH1:+12V, CH4:Vin
		+12Vsb	0.100					

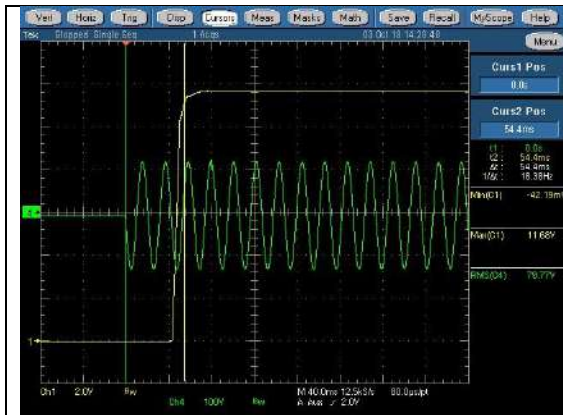

90V +12Vsb max CH1:+12Vsb, CH4:Vin

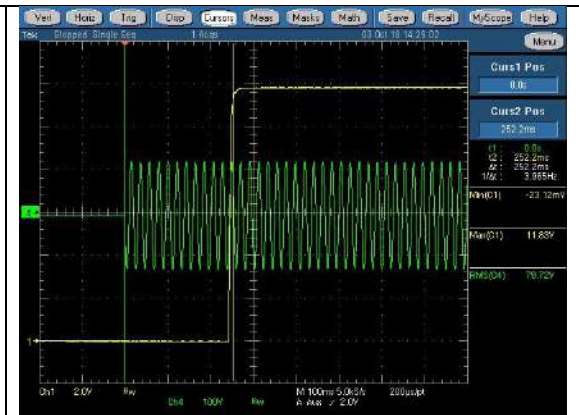

90V +12Vsb min CH1:+12Vsb, CH4:Vin

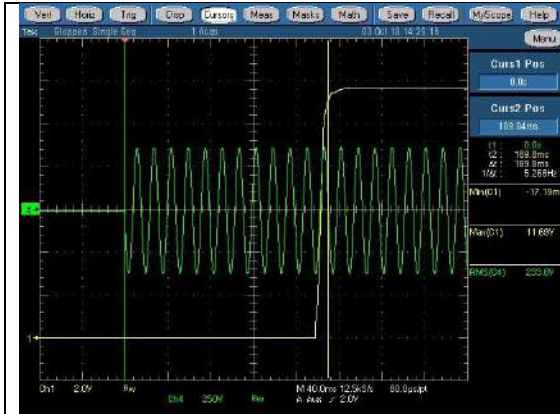

264V +12Vsb max CH1:+12Vsb, CH4:Vin

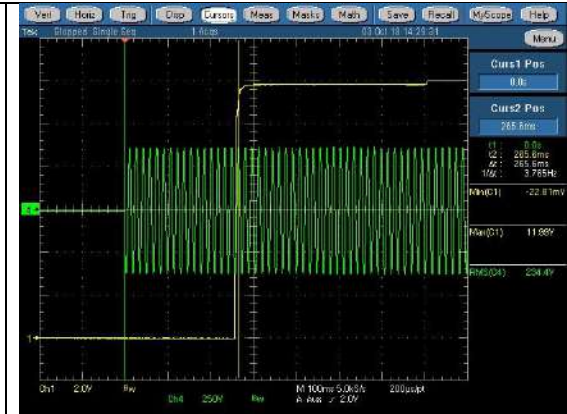

264V +12Vsb min CH1:+12Vsb, CH4:Vin

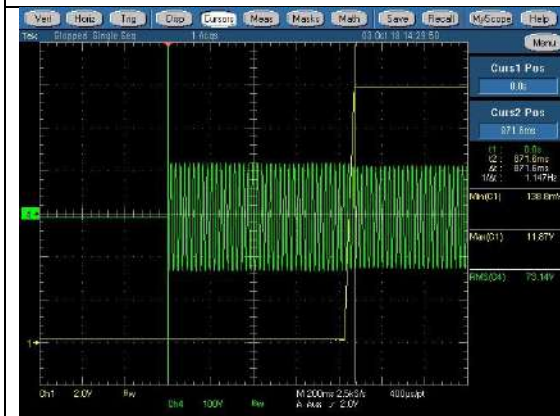

90V +12V max CH1:+12V, CH4:Vin

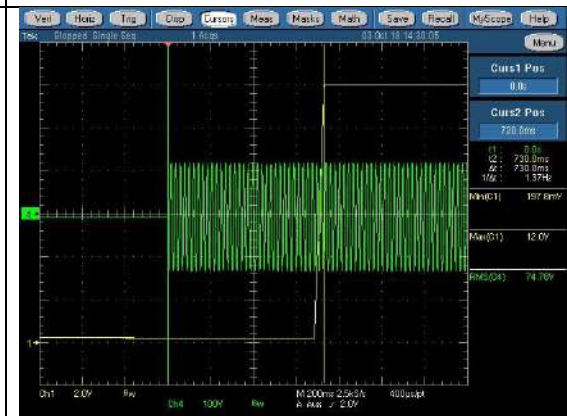

90V +12V min CH1:+12V, CH4:Vin



264V +12V max CH1:+12V, CH4:Vin

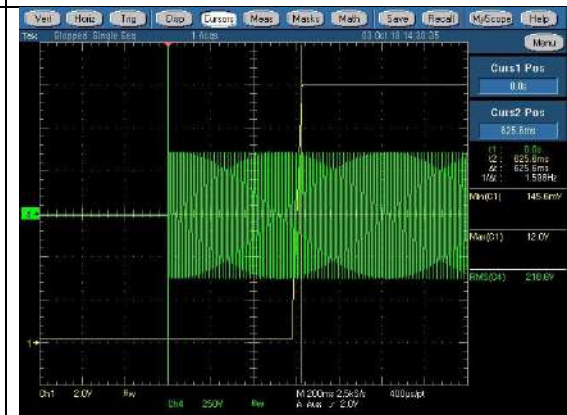

264V +12V min CH1:+12V, CH4:Vin

T vout_holdup								
Input		Output		Test Limits		Test Results	Pass / Fail	Remarks
Vin	Freq	Volt	Load	Min	Max			
90.00	47.00	+12V	43.830	13.000	*	15.760	PASS	90V +12V max

		+12Vsb	2.000					CH1:+12Vsb, CH2:+12V, CH3:PG, CH4:Vin
264.00	63.00	+12V	43.830	13.000	*	15.420	PASS	264V +12V max CH1:+12Vsb, CH2:+12V, CH3:PG, CH4:Vin
		+12Vsb	2.000					
90.00	47.00	+12V	43.830	12.000	*	16.100	PASS	90V PG max CH3:PG, CH4:Vin
		+12Vsb	2.000					
264.00	63.00	+12V	43.830	12.000	*	16.380	PASS	264V PG max CH3:PG, CH4:Vin
		+12Vsb	2.000					
90.00	47.00	+12V	43.830	70.000	*	748.400	PASS	90V +12Vsb max CH1:+12Vsb, CH2:+12V, CH3:PG, CH4:Vin
		+12Vsb	2.000					
90.00	47.00	+12V	0.500	70.000	*	6620.000	PASS	90V +12Vsb min CH1:+12Vsb, CH2:+12V, CH3:PG, CH4:Vin
		+12Vsb	0.100					
264.00	63.00	+12V	43.830	70.000	*	764.000	PASS	264V +12Vsb max CH1:+12Vsb, CH2:+12V, CH3:PG, CH4:Vin
		+12Vsb	2.000					
264.00	63.00	+12V	0.500	70.000	*	6704.000	PASS	264V +12Vsb min CH1:+12Vsb, CH2:+12V, CH3:PG, CH4:Vin
		+12Vsb	0.100					

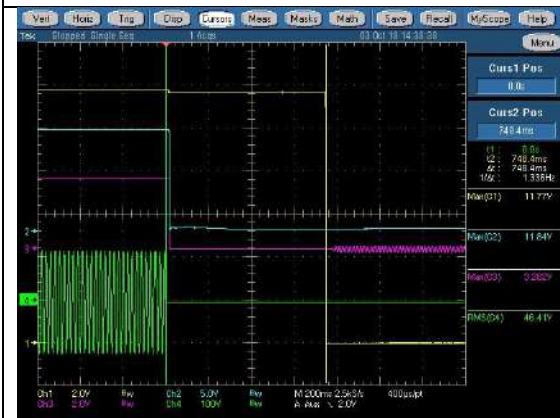
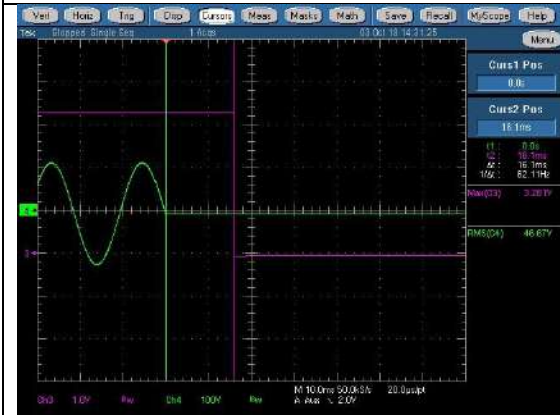

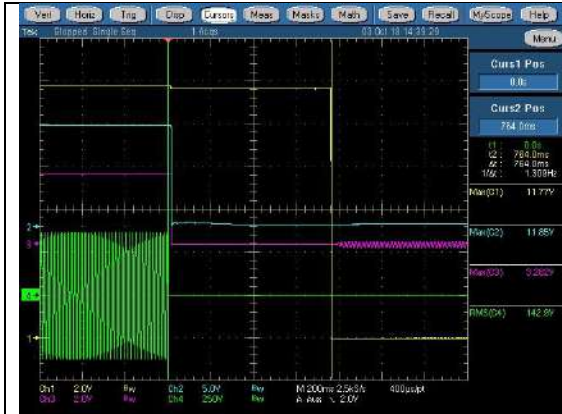

264V +12Vsb max CH1:+12Vsb, CH2:+12V, CH3:PG, CH4:Vin



264V +12Vsb min CH1:+12Vsb, CH2:+12V, CH3:PG, CH4:Vin

T pson_off_delay						Test Results	Pass / Fail	Remarks
Input		Output		Test Limits				
Vin	Freq	Volt	Load	Min	Max			
90.00	47.00	+12V	43.830	*	15.000	2.684	PASS	90V +12V max CH1:+12V, CH4:PS_On
		+12Vsb	2.000					
90.00	47.00	+12V	0.500	*	15.000	4.920	PASS	90V +12V min CH1:+12V, CH4:PS_On
		+12Vsb	0.100					
90.00	47.00	+12V	43.830	*	15.000	3.004	PASS	264V +12V max CH1:+12V, CH4:PS_On
		+12Vsb	2.000					
264.00	63.00	+12V	0.500	*	15.000	5.000	PASS	264V +12V min CH1:+12V, CH4:PS_On
		+12Vsb	0.100					



90V +12V max CH1:+12V, CH4:PS_On



90V +12V min CH1:+12V, CH4:PS_On



264V +12V max CH1:+12V, CH4:PS_On

264V +12V min CH1:+12V, CH4:PS_On

T pson_on_delay								
Input		Output		Test Limits		Test Results	Pass / Fail	Remarks
Vin	Freq	Volt	Load	Min	Max			
90.00	47.00	+12V	43.830	5.000	400.000	262.600	PASS	90V +12V max CH1:+12V, CH4:PS_On
		+12Vsb	2.000					
90.00	47.00	+12V	0.500	5.000	400.000	261.600	PASS	90V +12V min CH1:+12V, CH4:PS_On
		+12Vsb	0.100					
264.00	63.00	+12V	43.830	5.000	400.000	261.800	PASS	264V +12V max CH1:+12V, CH4:PS_On
		+12Vsb	2.000					
264.00	63.00	+12V	0.500	5.000	400.000	262.000	PASS	264V +12V min CH1:+12V, CH4:PS_On
		+12Vsb	0.100					



90V +12V max CH1:+12V, CH4:PS_On



90V +12V min CH1:+12V, CH4:PS_On



264V +12V max CH1:+12V, CH4:PS_On



264V +12V min CH1:+12V, CH4:PS_On

T _{pson_pwok_off_delay}								
Input		Output		Test Limits		Test Results	Pass / Fail	Remarks
Volt	Freq	Volt	Load	Min	Max			
90.00	47.00	+12V	43.830	*	5.000	0.400	PASS	90V PG_PSON max CH3:PG, CH4:PS_On
		+12Vsb	2.000					
90.00	47.00	+12V	0.500	*	5.000	0.667	PASS	90V PG_PSON min CH3:PG, CH4:PS_On
		+12Vsb	0.100					
264.00	63.00	+12V	43.830	*	5.000	0.359	PASS	264V PG_PSON max CH3:PG, CH4:PS_On
		+12Vsb	2.000					
264.00	63.00	+12V	0.500	*	5.000	0.676	PASS	264V PG_PSON
		+12Vsb	0.100					

								CH4:Vin
264.00	63.00	+12V	43.830	100.000	500.000	199.200	PASS	AC ON_264V +12V max CH1:+12Vsb, CH2:+12V, CH3:PG, CH4:Vin
		+12Vsb	2.000					
264.00	63.00	+12V	0.500	100.000	500.000	200.800	PASS	AC ON_264V +12V min CH1:+12Vsb, CH2:+12V, CH3:PG, CH4:Vin
		+12Vsb	0.100					

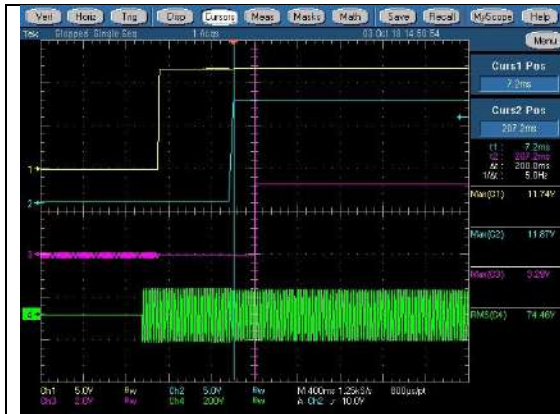

AC ON_90V +12V max CH1:+12Vsb, CH2:+12V, CH3:PG, CH4:Vin

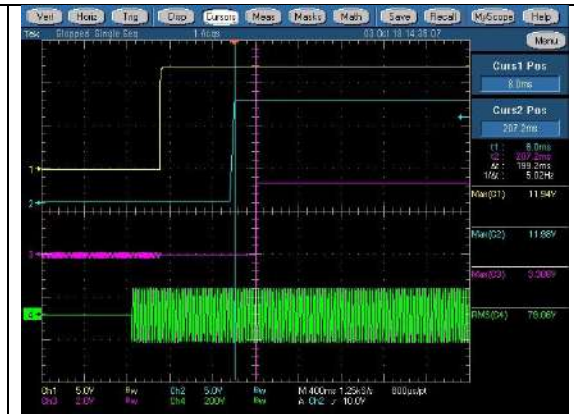

AC ON_90V +12V min CH1:+12Vsb, CH2:+12V, CH3:PG, CH4:Vin



AC ON_264V +12V max CH1:+12Vsb, CH2:+12V, CH3:PG, CH4:Vin



AC ON_264V +12V min CH1:+12Vsb, CH2:+12V, CH3:PG, CH4:Vin

T sb_vout_on_delay								
Input		Output		Test Limits		Test Results	Pass / Fail	Remarks
Volt	Freq	Volt	Load	Min	Max			
90.00	47.00	+12V	43.830	50.000	1000.000	688.800	PASS	90V +12Vsb_+12V max CH1:+12Vsb, CH2:+12V, CH4:Vin
		+12Vsb	2.000					
90.00	47.00	+12V	0.500	50.000	1000.000	687.200	PASS	90V +12Vsb_+12V min CH1:+12Vsb, CH2:+12V, CH4:Vin
		+12Vsb	0.100					
264.00	63.00	+12V	43.830	50.000	1000.000	436.000	PASS	264V +12Vsb_+12V max CH1:+12Vsb, CH2:+12V, CH4:Vin
		+12Vsb	2.000					
264.00	63.00	+12V	0.500	50.000	1000.000	436.400	PASS	264V +12Vsb_+12V min CH1:+12Vsb, CH2:+12V, CH4:Vin
		+12Vsb	0.100					



90V +12Vsb_+12V max CH1:+12Vsb, CH2:+12V, CH4:Vin



90V +12Vsb_+12V min CH1:+12Vsb, CH2:+12V, CH4:Vin



264V +12Vsb_ +12V max CH1:+12Vsb,
CH2:+12V, CH4:Vin



264V +12Vsb_ +12V min CH1:+12Vsb,
CH2:+12V, CH4:Vin

Rise Time								
Input		Load		Test Limits		Test Results	Pass/Fail	Remarks
Vin	Freq	12V	12Vsb	Min	Max			
90.00	47.00	43.830	2.000	5.000	70.000	36.095	PASS	90V +12V max CH1:+12V
90.00	47.00	0.500	0.100	5.000	70.000	36.864	PASS	90V +12V min CH1:+12V
264.00	63.00	43.830	2.000	5.000	70.000	33.955	PASS	264V +12V max CH1:+12V
264.00	63.00	0.500	0.100	5.000	70.000	36.901	PASS	264V +12V min CH1:+12V
90.00	47.00	43.830	2.000	1.000	25.000	7.562	PASS	90V +12Vsb max CH1:+12Vsb
90.00	47.00	0.500	0.100	1.000	25.000	6.988	PASS	90V +12Vsb min CH1:+12Vsb
264.00	63.00	43.830	2.000	1.000	25.000	7.861	PASS	264V +12Vsb max CH1:+12Vsb
264.00	63.00	0.500	0.100	1.000	25.000	6.799	PASS	264V +12Vsb min CH1:+12Vsb

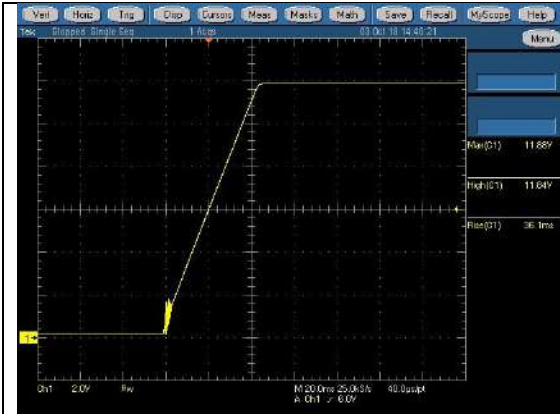

90V +12V max CH1:+12V



90V +12V min CH1:+12V



264V +12V max CH1:+12V

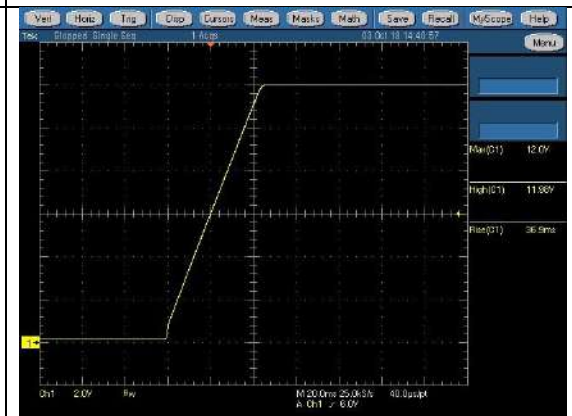

264V +12V min CH1:+12V

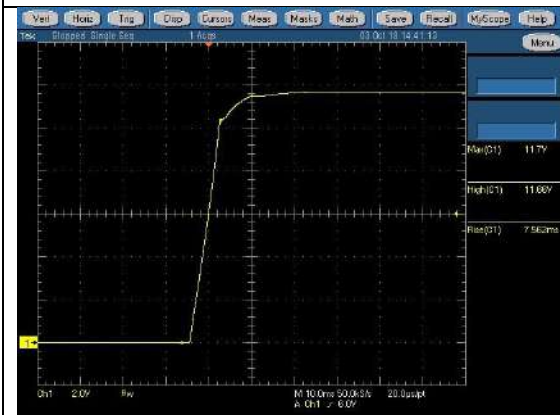

90V +12Vsb max CH1:+12Vsb

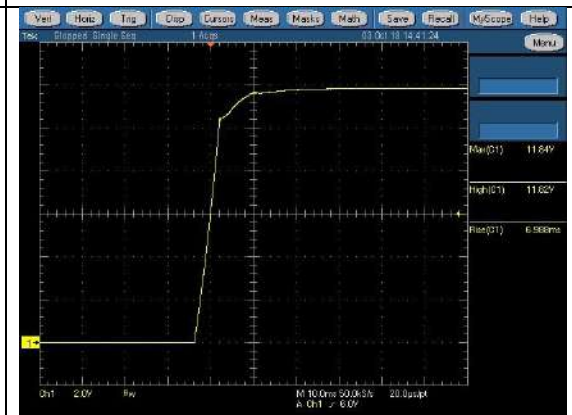

90V +12Vsb min CH1:+12Vsb

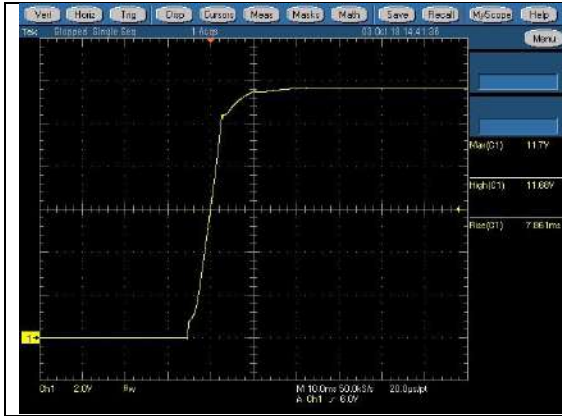

264V +12Vsb max CH1:+12Vsb



264V +12Vsb min CH1:+12Vsb