



# 康舒科技

ACBEL POLYTECH INC.



## Approval Sheet

**Model No.** : FSD002 Option 4QAG  
**MKT Model No.** : R1BU5301 Option G4QA  
**Hardware Rev.** : A02  
**Software Rev.** : APM12V0308

**Customer** : AIC INC.  
**Customer PN** : PH-000000020\_A03

**Approval by :** Smith Lu

**Prepare by** : Sonia Chuang

**Date:** 04/15/2019





**康舒科技**

ACBEL POLYTECH INC.

# Contents

- 1. Specification**
- 2. Mechanical Outline Drawing**
- 3. I/O Label Drawing**
- 4. ATE Test Report**



**康舒科技**

ACBEL POLYTECH INC.

# Specification



ACBEL POLYTECH INC.

# ERP1U 300W

---

## 1U 1+1 Redundant Distribution Board Specification

Model Number: R1BU5301B-G Series  
AcBel PN: FSD002 Series

use R1Bb Module Series

Revision: S03

Release Date: 2014/04/23

Released by: Johnny Ho

Change Date: 2015/07/08

Changed by: Johnny Ho



### 1. GENERAL SCOPE

This specification describes the performance characteristic of a DC-DC switching power distribution board (PDB) with a +12V main DC input and a +5Vsb auxiliary input. The PDB will switch into +5V, +3.3V, -12V main and +5Vsb auxiliary output and distribute +12V main output. The PDB operates with a single power supply or in N+1 parallel. Power modules shall support hot-plug and active load share for 12V Main output. Mixed operation of different input type power modules (AC-DC and DC-DC) is allowed. The PDB shall limit the OPP to 300W continuous power operation.

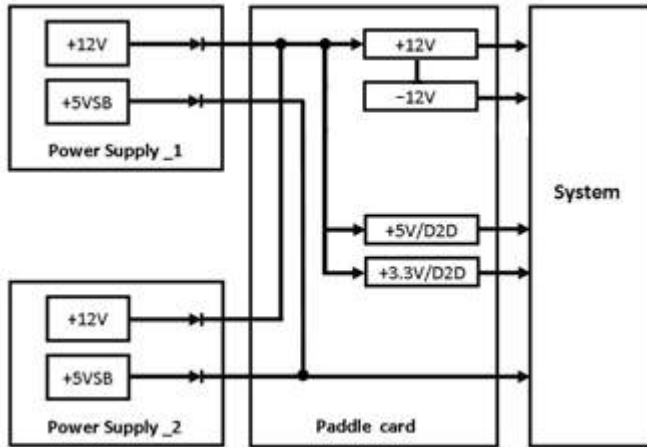

Figure 1- General Architecture

### 2. ELETRICAL PERFORMANCE

#### 2.1 POWER BUS AND SIGNAL CONNECTOR

The PDB shall have a common Power Bus and signal connector complying with Molex interconnects series. The exact PN for interconnect is **Molex PN 45984-4143 or equivalent.**

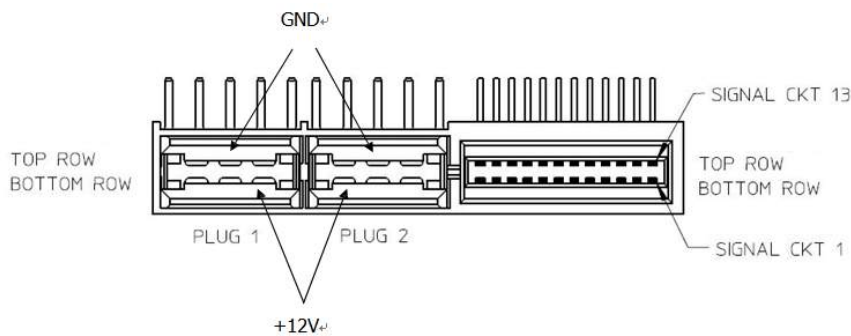

Figure 2 – PDB Connector – PDB sides.

The Pin definition shall comply with table 1 below and shall provide 12VDC as main input and 5VsbDC as auxiliary input.

PSU DC +12V output is on the bottom set of 2 power pins (blades). And PSU DC GROUND is on the top set of 2 power pins (blades). The +12V pins should touch last and break first and

the DC GROUND pins should touch first and break last when the PSU is mated to the PDB connector.

The PSU must have tabs on its card edge to mate with the PDB connector, similar to that shown in the following figure.

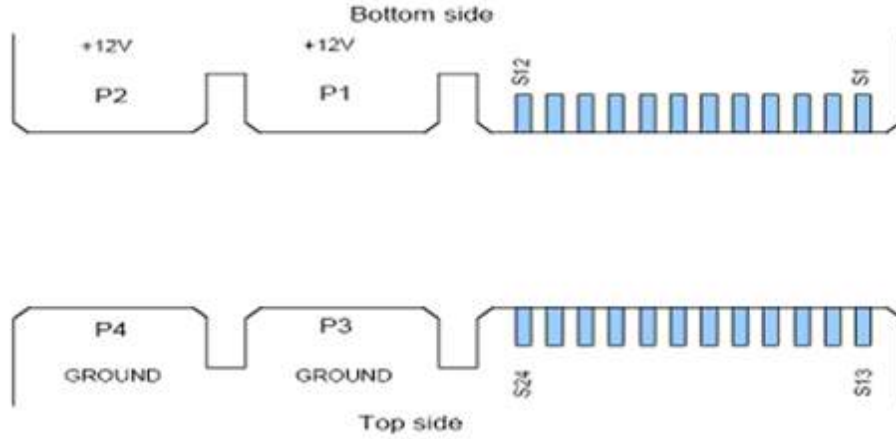

Figure 3 – Golden finger – PSU sides (Top View)

**Table 1 - Input connector pin assignment:**

Pin Name	Signal Name	Function	Pin Name	Signal Name	Function
P1 & P2	Main_Output (MO+)	+12V (Bottom)	S13	N/C	N/C
P3 & P4	RTN (GND)	+12V return (Top)	S14	Present#	PS present
S1	Remote Sense (+)	+12VS	S15	A0	I <sup>2</sup> C address bit 0
S2	Remote Sense (-)	+12V RTN Sense	S16	N/C	N/C
S3	12LS	Current share bus	S17	N/C	N/C
S4	SMB_Alert	Failure notification	S18	EEPROM	EEPROM_WP
S5	SDA	I <sup>2</sup> C Data signal	S19	Input_OK#	Input present signal
S6	SCL	I <sup>2</sup> C Clock signal	S20	N/C	N/C
S7	N/C	N/C	S21	CR	Cold Redundant
S8	PSON	Power enable input	S22	N/C	N/C
S9	PWOK	Power output	S23	+5Vsb	+5Vsb output
S10	A1	I <sup>2</sup> C address bit 1	S24	+5Vsb	+5Vsb output
S11	+5Vsb	+5Vsb output			
S12	+5Vsb	+5Vsb output			

Notes:

1. The +3.3V/+5V/+12V/-12V derives their power from +12V.
2. PDB will pass +5V<sub>SB</sub> to system.
3. See section 6, "Signal Definition"

**2.2 POWER INPUT SPECIFICATION**

**2.2.1 Input Voltage**

The maximum input current defines the maximum possible input current to ensure the proper function of the PDB to meet all defined specifications.

INPUT VOLTAGE	INPUT CURRENT	MAX POWER
12VDC	24A	288W
5V <sub>SB</sub> DC	2.5A	12.5W

**2.2.3 Efficiency**

The D2D converter shall have at least an efficiency rating in the table below:

Load	Minimum Efficiency	
	+5V	+3.3V
20%	92%	90%
50%	94%	92%
100%	93%	91%

**2.2.3.1 Efficiency of multi-output power system**

The efficiency of multi-output power system should be measured at 230VAC with following criteria and meet the efficiency requirements:

Configuration	Load	Minimum Efficiency
1+0	20%	80%
1+1	50%	80%

**2.3 POWER OUTPUT SPECIFICATION**

**2.3.1 Output Power/Currents**

The following table defines the power and current rating of a PDB, which supports up to combined 300W output power and power module output limitation. The combined output power of all outputs shall not exceed the rated output power. The power supply system must meet both static and dynamic voltage regulation requirements.

The maximum combined steady output power shall follow by below table, no matter how the current draw will be combined.

**Output Current Table:**

Voltage	Mini	Max
+3.3V	0.1A	15A
+5V	0.1A	18A
-12V	0.0A	0.3A
+12V	follow PSU	24A
+5Vsb	follow PSU	follow PSU

1. Maximum continuous total DC output power should not exceed 300W.
2. The +3.3V/+5V/+12V/-12V derives their power from +12V.

**2.3.2 Voltage Regulation**

The power supply shall stay within the following voltage limits when operating at steady state and dynamic loading conditions. These limits include the peak-peak ripple/noise conditions specified in paragraph 2.2.5. All outputs are measured with reference to the return remote sense (ReturnS) signal.

Parameter	MIN	NOM	MAX	Units	Tolerance
+3.3V	+3.13	+3.30	+3.47	V <sub>rms</sub>	+/-5%
+5V	+4.75	+5.00	+5.25	V <sub>rms</sub>	+/-5%
+12V	+11.40	+12.00	+12.60	V <sub>rms</sub>	+/-5%
-12V	-11.40	-12.00	-13.20	V <sub>rms</sub>	+10/-5%
+5Vsb	+4.75	+5.00	+5.25	V <sub>rms</sub>	+/-5%

**2.3.3 Dynamic Loading**

The power supply shall operate within specified limits and meet regulation requirements for step loading and capacitive loading specified below.

The load transient repetition rate shall be tested between 50Hz to 5kHz at duty cycles ranging from 10%-90%. The load transient repetition rate is only a test specification. The Δ step load may occur anywhere within the MIN load and the MAX load.

Output	ΔStep Load Size	Load Slew Rate	Capacitive Load
+3.3V	30% of max load	0.5 A/μs	470 μF
+5V	30% of max load	0.5 A/μs	470 μF
+12V	30% of max load	0.5 A/μs	470 μF
+5Vsb	30% of max load	0.5 A/μs	10 μF

**2.3.4 Capacitive Loading**

The power supply shall meet all requirements with the following capacitive loading ranges.

Output	MIN	MAX	Units
+3.3V	470	8,000	μF
+5V	470	8,000	μF
+12V	follow PSU	follow PSU	μF
+5Vsb	follow PSU	follow PSU	μF

**2.3.5 Ripple and Noise**

Ripple and Noise shall be measured over a Bandwidth of 20MHz at the power supply output connector. A 0.1µF ceramic capacitor and 10µF of tantalum capacitor shall be placed at each point of measurement.

+3.3V	+5V	-12V	+12V	+5Vsb
50 mVp-p	50 mVp-p	120mVp-p	follow PSU	follow PSU

**2.3.6 Maximum Load Change**

The power supply shall continue to operate normally when there is a step change  $\leq 1 \text{ A}/\mu\text{sec}$  between minimum load and maximum load.

**3. TIMING SEQUENCE**

These are the timing requirements for the power supply operation. The output voltages must rise from 10% to within regulation limits ( $T_{\text{vout\_rise}}$ ) within 5 to 70ms. For 5Vsb, it is allowed to rise from 1 to 25ms. All main outputs shall rise positive monotonically and have a slop value between 0 V/mS to 0.1V/mS.

For 5Vsb output any 5ms segment of the 10% to 90% rise time waveform, a straight line draw between the end points of the waveform segment must have a slope  $\geq [V_{\text{out, nominal}}/20] \text{V/mS}$ .

Each output voltage shall reach regulation within 5mS ( $T_{\text{vout\_on}}$ ) of each other during turn on of the power supply system. Each output voltage shall fall out of regulation within 400mS ( $T_{\text{vout\_off}}$ ) of each other during turn off.

Table below shows the timing requirements for the power supply being turned on and off via the input power, with PSON held low and the PSON signal, with the input power applied.

Item	Description	MIN	MAX	Units
$T_{\text{vout\_rise}}$	Output voltage rise time for all main output	1	70	ms
	Output voltage rise time for the 5Vsb output	1	25	ms
$T_{\text{vout\_on}}$	All main outputs must be within regulation of each other within this time.		50	ms
$T_{\text{vout\_off}}$	All main outputs must leave regulation within this time.		400	ms

### Output Voltage Timing

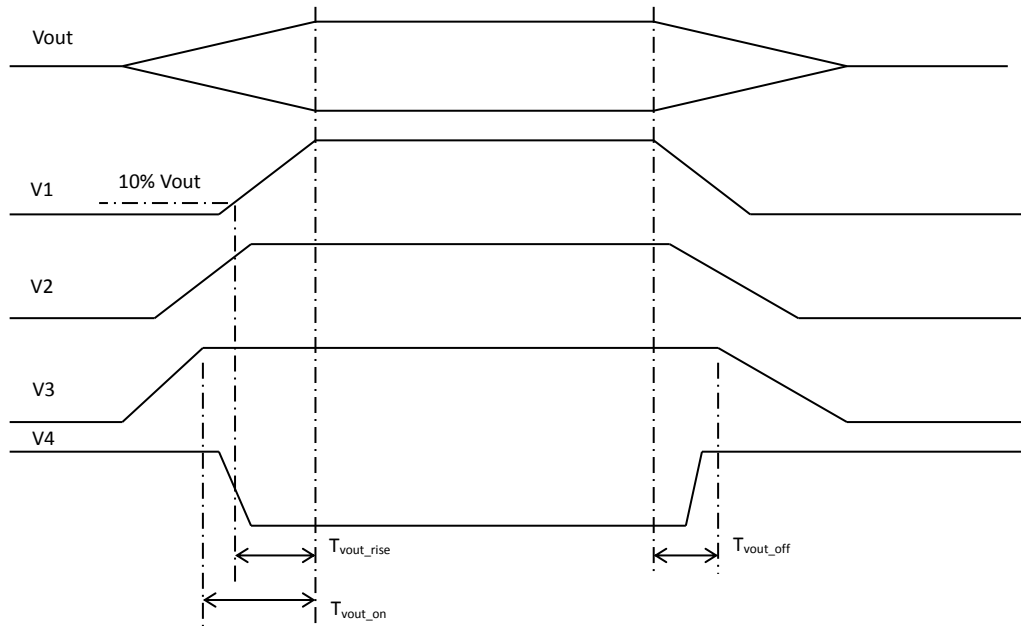

### Turn On/Off Timing

Item	Description	MIN	MAX	UNITS
T <sub>sb_on_delay</sub>	Delay from ac begin applied to 5Vsb begin within regulation.		1500	ms
T <sub>ac_on_delay</sub>	Delay from AC begin applied to all output voltage begin within regulation.		2500	ms
T <sub>out_holdup</sub>	Time all output voltages stay within regulation after loss of AC.	12		ms
T <sub>pwok_holdup</sub>	Delay from loss of AC to de-assertion of PWOK.	10		ms
T <sub>pson_on_delay</sub>	Delay from PSON# active to output voltages within regulation limits.	5	400	ms
T <sub>pson_pwok</sub>	Delay from PSON# de-active to PWOK begin de-asserted.		50	ms
T <sub>pwok_on</sub>	Delay from output voltages within regulation limits to PWOK asserted at turn on.	100	500	ms
T <sub>pwok_off</sub>	Delay from PWOK de-asserted to output voltages (3.3V, 5V, 12V, -12V) dropping out of regulation limits.	1		ms
T <sub>psok_low</sub>	Duration of PWOK begin in the de-asserted state during an off/on cycle using AC or the PSON# signal.	100		ms
T <sub>sb_vout</sub>	Delay from 5Vsb begin in regulation to O/Ps begin in regulation at AC turn on.	50	1000	ms

#### 4. CONTROL AND INDICATOR FUNCTIONS

The following section defines the input and output signals from the power supply. Signals that can be defined as low true use the following convention:  
Signal<sup>#</sup> = low true.

##### 4.1 PSON<sup>#</sup> INPUT SIGNAL (POWER SUPPLY ENABLE)

The PSON<sup>#</sup> signal is required to remotely turn on/off the main output of the power supply. PSON<sup>#</sup> is an active low signal that turns on the main output power rail. When this signal is not pulled low by the system or left open, the outputs (except the Standby output) turn off. PSON<sup>#</sup> is pulled to a standby voltage by a pull-up resistor internal to the power supply.

**PSON<sup>#</sup> Signal Characteristic**

Signal Type	Accepts an open collector/drain input from the system. Pull-up to VSB located in the power supply.	
PSON <sup>#</sup> = Low	ON	
PSON <sup>#</sup> = High or Open	OFF	
	MIN	MAX
Logic level low (power supply ON)	0V	1.0V
Logic level high (power supply OFF)	2.0V	3.46V
Source current, V <sub>pson</sub> = low		4mA
Power up delay: T <sub>pson_on_delay</sub>	5ms	400ms
PWOK delay: T <sub>pson_pwok</sub>		50ms
T <sub>pson</sub> = Delay PSON# disconnect MO OFF		100μsec

### PSON# Signal Characteristic

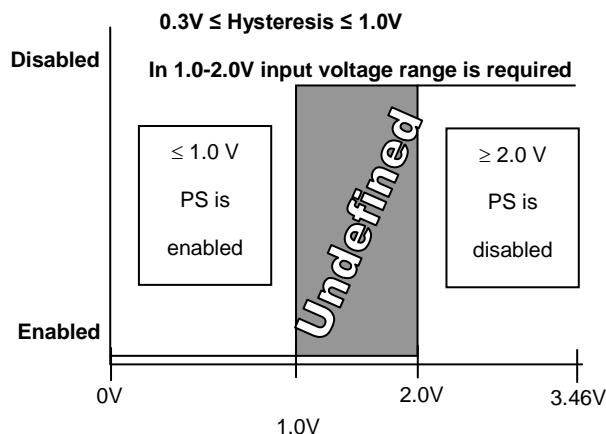

#### 4.2 POWER OK (PWOK OR PG) BUS

PWOK is a power good signal and shall be pulled HIGH by the power supply to indicate that all outputs are within regulation limits. When any output voltage falls below regulation limits, an internal failure or when AC power has been removed for a time sufficiently long, so that power supply operation is no longer guaranteed, PWOK will be de-asserted to a LOW state. The start of the PWOK delay time shall inhibited as long as any power supply output is in current limit.

#### PWOK / PG Signal Characteristics

<b>Signal Type</b>	Open collector/drain output from power supply. Pull-up to Vsb located in power supply.	
<b>PWOK = High</b>	Power OK	
<b>PWOK = Low</b>	Power Not OK	
	<b>MIN</b>	<b>MAX</b>
<b>Logic level low voltage, I<sub>sink</sub> = 4mA</b>	0V	0.4V
<b>Logic level high voltage, I<sub>source</sub> = 200µA</b>	2.4V	3.46V
<b>Sink current, PWOK = low</b>		4mA
<b>Source current, PWOK = high</b>		2mA
<b>PWOK delay: T<sub>pwok_on</sub></b>	100ms	500ms
<b>PWOK rise and fall time</b>		100µsec
<b>Power down delay: T<sub>pwok_off</sub></b>	1ms	200ms

#### 4.3 SMBAlert# Signal

This signal indicates that the power supply is experiencing a problem that the user should investigate. This shall be asserted due to Critical events or Warning events. The signal shall activate in the case of critical component temperature reached a warning threshold, general failure, over-current, over-voltage, under-voltage, failed fan. This signal may also indicate the power supply is reaching its end of life or is operating in an environment exceeding the specified limits.

**SMBAlert<sup>#</sup> signal characteristics**

<b>Signal Type</b>	Open collector/drain output from power supply. Pull-up to Vsb located in power supply.	
Alert <sup>#</sup> =High	Power OK	
Alert <sup>#</sup> =Low	Power Alert to system	
	<b>MIN</b>	<b>MAX</b>
<b>Logic level low voltage, I<sub>sink</sub>=4mA</b>	0V	0.4V
<b>Logic level high voltage, I<sub>sink</sub> = 50µA</b>	2.4V	3.46V
<b>Sink current, Alert<sup>#</sup>=low</b>		4mA
<b>Sink current, Alert<sup>#</sup>=high</b>		50µA
<b>50µA rise and fall time</b>		100µsec
<b>SmaRT input power fail assertion</b>		2msec
<b>Thermal CLST ΔT to critical thermal</b>	10°C	

**5. PROTECTION CIRCUITS**

Protection circuits inside the PDB shall cause only the main output to shutdown (latch off). If the power supply latches off due to a protection circuit assert, an Input Power cycle OFF for 15sec or a PSON<sup>#</sup> cycle HIGH for 1sec shall be able to reset the power supply.

Specific protection circuits shall not latch, but auto recover when the latching reason had been cleared. This protection circuits will be written in cursive writing and will have an Auto Recover (Output<sub>Ar</sub>) in the chapter name.

The auxiliary output shall not affect by any protection circuit, unless the auxiliary output itself is affected.

**5.1 CURRENT LIMIT**

The power supply shall prevent the main and auxiliary outputs from exceeding the values shown in below Table. If the main current limits are exceeded the power supply will shut down and latch off, *the auxiliary output shall be auto recover (Vsb<sub>AR</sub>) after the OCP had been removed.*

The PDB shall alert the system of the OCP condition via SMBAlert<sup>#</sup>.

**Over Current Protection**

<b>Voltage</b>	<b>Over Current Limit (Iout limit)</b>
+3.3V	110% - 150% maximum
+5V	110% - 150% maximum
+12V	110% - 150% maximum
+5Vsb (Auxiliary)AR*	follow PSU module *NOTE

Note: +5Vsb for PDB was a pass through design, in single power module had maximum 6A limit.

### 5.2 OVER VOLTAGE PROTECTION

The power supply shall shutdown and latch off after an over voltage condition occurs. This latch will be cleared by toggling the PSON# signal or by an AC power interruption.

The PDB shall alert the system of the OVP condition via SMBAlert<sup>#</sup>.

**Over Voltage Limits**

Output Voltage	MIN (V)	MAX (V)
+3.3V	3.6	4.5
+5V	5.55	6.55
+12V	follow PSU	follow PSU
+5Vsb ( <i>Auxiliary</i> )AR	follow PSU	follow PSU

Note: +12V OVP is set 14.5V; +5Vsb is 6.5V

### 5.3 UNDER VOLTAGE PROTECTION

The power supply shall shutdown and latch off after an under voltage condition occurs. This latch will be cleared by toggling the PSON# signal or by an AC power interruption.

The PDB shall alert the system of the UVP condition via SMBAlert<sup>#</sup>.

The +3.3V/+5V/+12V/+5Vsb UV setting as below:

**Under Voltage Limits**

Output Voltage	MIN (V)	MAX (V)
+3.3V	2.3	3
+5V	3.5	4.4
+12V	follow PSU	follow PSU
+5Vsb ( <i>Auxiliary</i> )AR	follow PSU	follow PSU

### 5.4 SHORT CIRCUIT PROTECTION

The power supply shall shutdown and latch off after an under voltage condition occurs. This latch will be cleared by toggling the PSON# signal or by an AC power interruption.

The PDB shall alert the system of the SCP condition via SMBAlert<sup>#</sup>.

**Short Circuit Protection**

Voltage	Min Short Circuit Threshold
+3.3V	30A
+5V	30A
+12V	follow PSU
+5Vsb ( <i>Auxiliary</i> )AR*	follow PSU

## 5.5 RESTART AFTER LATCH OFF

Restart can be accomplished in one of two ways:

1. By toggling the PDB\_ON# signal from active to inactive to active. The duration of inactive time should be longer than 10 msec.
2. By removing all PSUs for at least 1 second. And then plug PSU in.

## 6. SIGNAL DEFINITION

### 6.1 PDB\_ON#

The PDB\_ON# is an open collector active low output signal of system, and it is an input signal of PDB. System controls PDB on or off via this signal. When the signal is active, PDB will turn on. When the signal is inactive, PDB will shut down.

This signal is considered logically low if its level is 0.8V or less. It is considered logically high if its level is 2V or higher.

System must not pull this signal up.

### 6.2 PSU\_ON#

The PSU\_ON# is a logic low output signal of PDB, and it is an input signal of PSUs. Two PSU's PSU\_ON# pins are wired together by PDB. PDB controls PSUs On or Off via this signal. When this signal is high, the PSU output will turn On is PSU AC input is ready. When this signal is low, the PSU output will turn Off.

This signal is considered logically low if its level is 0.8V or less. It is considered logically high if this level is 2V or higher.

PSU must pull this signal up via 10K~47Kohm

### 6.3 PDB\_OK

The PDB\_OK is a logic high output signal of PDB, and it is an input signal of system. When PDB status is OK, PDB\_OK signal will be high. When PDB status is not OK, PDB\_OK signal will be low.

This signal is considered logically low if its level is 0.8V or less. It is considered logically high if its level is 2V or higher.

System must pull this signal up via 10K~47Kohm

### 6.4 PSU\_OK

The PSU\_OK is an open collector output of PDU, and it is a logic high signal of PDB. It used to indicate the PDU status. When PDU status is OK, PSU\_OK signal will be pull high to PDB internal bias. When PSU status is not OK, PDB\_OK signal will be active low.

This signal is considered logically low if its level is 0.8V or less. It is considered logically high if its level is 2V or higher, PSU must not pull this signal up.

## 6.5 AC\_OK

The AC\_OK is an open collector output of PSU, and it is a logic high input of PDB. It used to indicate the PSU AC status. When PSU AC status is OK, AC\_OK signal will be pull high to PDB internal bias. When PSU status is not OK, AC\_OK signal will be active low.

This signal is considered logically low if its level is 0.8V or less. It is considered logically high if its level is 2V or higher.

PSU must not pull this signal up.

## 6.6 PRESENT#

The PRESENT# is logic low input of PDB, and it is an output of PSU. It used to indicate the PSU's presence. The PSU wires this signal to ground.

PSU must wire this signal to ground.

## 6.7 12VRS+ & 12VRS-

The 12VRS+ and 12VRS- were for +12V remote sensing. PDB wires these two signals to +12V and GND of output connector terminals for voltage compensation.

## 6.8 3.3VRS+ & 5VRS+

The 3.3VRS+ and 5VRS+ were for +3.3V and +5V remote sensing. PDB wires these two signals to +3.3V and +5V output connector terminals voltage compensation.

## 6.9 12VLS

12VLS is 12V current sharing bus of active-current-sharing method. Two PSU's 12VLS pins are wired together by PDB, and PSUs will equalize 12V output load by this signal.

If PSU doesn't support active-current-sharing method, PSU must left this pin open.

## 6.10 SERIAL BUS COMMUNICATION

The PDB will communicate with system by serial bus. The buses are compatible with Vdd =3.3V,

100kHz, and SMBus 2.0 'high power'. The following signals will be used for this communication.

System must pull these pins to 3.3V.

## 6.11 SMBus\_Clock

Bi-directional signal used to synchronize communications. The SMBus\_Clock pins of PDB, PSU and system should be wired together.

This signal is considered logically low if its level is 0.8V or less. It is considered logically high if its level is 2.1V or higher.

System must pull this signal up via 10k~47kohm. PSU must not pull this signal up.

### 6.12 SMBus\_Data

Bi-directional signal used to synchronize communications. The SMBus\_Data pins of PDB, PSU and system should be wired together.

This signal is considered logically low if its level is 0.8V or less. It is considered logically high if its level is 2.1V or higher.

System must pull this signal up via 10k~47kohm. PSU must not pull this signal up.

### 6.13 PSU\_SMBUS\_Alert# & PDB\_SMBUS\_Alert#

PSU\_SMBus\_Alert# is generated by the PSU whenever it experiences a problem that the system should know about. PDB\_SMBus\_Alert# is a logical AND of two PSUs' PSU\_SMBus\_Alert#. Any problem experienced by the PSU or PDB will cause PDB\_SMBus\_Alert# to assert. This signal is considered logically low if its level is 0.8V or less. It is considered logically high if its level is 2.1V or higher.

System must pull this signal up via 10k~47kohm. PSU must not pull this signal up.

### 6.14 A0

A0 is a signal to set up PSU serial bus address. The PSU must pull this signal up via 10k~47k ohm. A0 pin of PSU1 will be wired to ground by PDB. And A0 pin of PSU2 will be left open.

The setting is as following picture

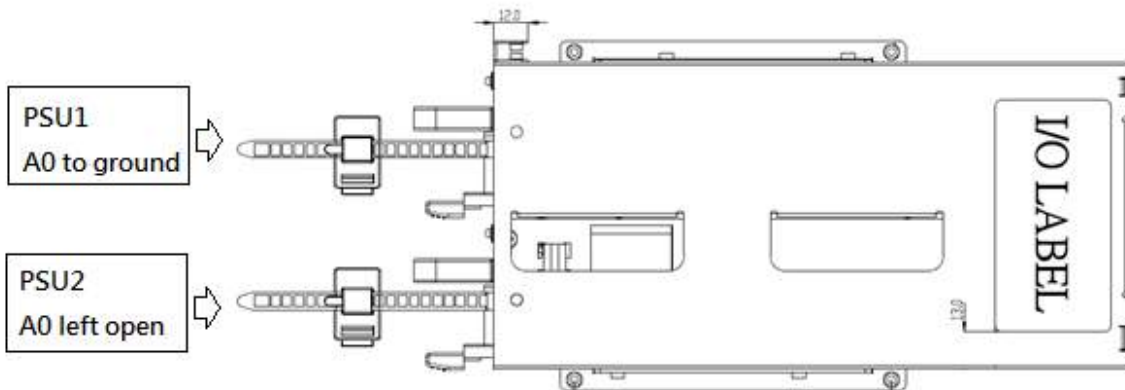

## 7. SERIAL BUS COMMUNICATION

### 7.1 STATUS AND FAULT INFORMATION

The commands in the following table are system read only.

**Status Command Code**

Command Code	Command Name	bit	Status
F0h	MFR SPECIFIC 32	5	AC_OK_PSU2
		4	AC_OK_PSU1
		3	PSU_OK_PSU2
		2	PSU_OK_PSU1
		1	PRESENT#_PSU2
		0	PRESENT#_PSU1
		4	3.3V_lout OC Fault
		3	5V_lout OC Fault
		0	12V_lout OC Fault
		4	3.3V_Vout UV Fault
		3	5V_Vout UV Fault
		2	Reserve
		1	3.3V_Vout OV Fault
		0	5V_Vout OV Fault

**Status Information**

I2C STATUS	STATUS GOOD	STATUS Fail
AC_OK_PSU2	bit=1	bit=0
AC_OK_PSU1	bit=1	bit=0
PSU_OK_PSU2	bit=1	bit=0
PSU_OK_PSU1	bit=1	bit=0
PRESENT#_PSU2	bit=1	bit=0
PRESENT#_PSU1	bit=1	bit=0

## 8. ENVIRONMENTAL

### 8.1 TEMPERATURE REQUIREMENTS

The power supply shall operate within all specified limits over the Top temperature range. The average air temperature difference ( $\Delta T_{ps}$ ) from the inlet to the outlet of the power supply shall not exceed the values shown below Table. All airflow shall pass through the power supply and not over the exterior surfaces of the power supply

ITEM	DESCRIPTION	MIN	MAX	UNITS
Top	Operating temperature range.	0	45	°C
Tnon-op	Non-operating temperature range.	-40	60	°C

## 8.2 HUMIDITY

Operating: 20% to 85% relative humidity, non-condensing.

Storage: 10% to 90% relative humidity, non-condensing.

## 8.3 ALTITUDE

Operating: to 10,000ft (3,050m)

Non-operating: to 25,000ft

## 8.4 VIBRATION

Operating: 0.01G<sup>2</sup>/Hz at 10Hz, 0.02G<sup>2</sup>/Hz at 20Hz.

Non-Operating: 0.02G<sup>2</sup>/Hz from 20Hz to 1000Hz.

## 8.5 MECHANICAL SHOCK

Operating: 5G, no malfunction.

Non-operating: 50G, no damage. Trapezoidal Wave, Velocity change = 4.3m/sec. Three drops in each of six directions are applied to each of the samples.

## 8.6 EMI/EMC REQUIREMENTS

The power supply shall comply with FCC part 15, CRISP 22 and EN55-22; Class A for both conducted and radiated emissions with a 6dB margin. Test shall be conducted using a shielded DC output cable to a shielded load. The load shall be adjusted to 100% load. Tests will be performed full load on each output power at 120VAC, 60Hz, and 230VAC, 50Hz.

## 9. REGULATORY REQUIREMENTS

### 9.1 PRODUCT SAFETY COMPLIANCE

The PDB shall meet following safety regulation with most current editions:

- A) UL 60950-1/CSA 60950-1 Edition 2 (USA/Canada)
- B) TUV EN60950-1 Edition 2 (Europe)
- C) IEC60950-1 Edition 2 (International)
- D) CB Certificate & Report, IEC60950-1 Edition 2
- E) CE – Low Voltage Directive 2006/95/EC (Europe)
- F) BSMI (Taiwan)
- G) GB4943-2011 Certification (China)

## 10. RELIABILITY

The MTBF of the power supply can be calculated with the Part-Stress Analysis method of Bell Core SR-332 Issue 1 using the quality factors. A calculated MTBF of the power supply shall be at least 100,000 hours at 40 °C ambient with 115VAC and in 80% load condition.

## 11. RoHS COMPLIANCE

The directive 2002/95/EC of the European Parliament and of the Council of the 27th January 2003, on the restriction of the use of certain hazardous substances in electrical and electronic equipment, requires the reduction of the substances Lead, Mercury, Cadmium, Hexavalent Chromium, Polybrominated Biphenyls (PBB), and Polybrominated Biphenyl ethers (PBDE) in electronic products by July 1, 2006. Unless otherwise noted, all materials used will be compliant with this directive and any subsequent revisions or amendments.

## 12. MECHANICAL DIMENSIONS

### 12.1 POWER SYSTEM DIMENSIONS

Dimension (L x W x H): 220 x 106 x 41.5mm / 8.66 x 4.17 x 1.63inch

Note: Bracket is an optional item upon request.

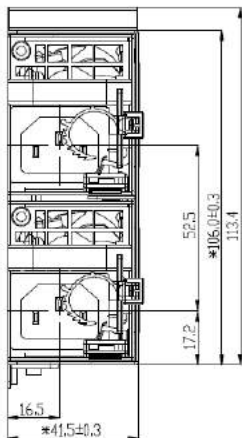
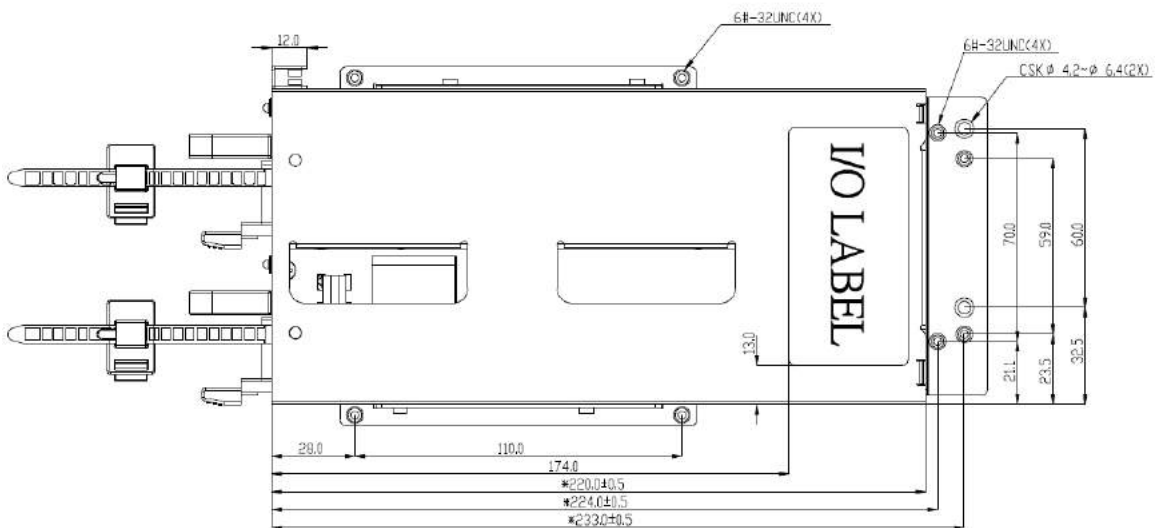
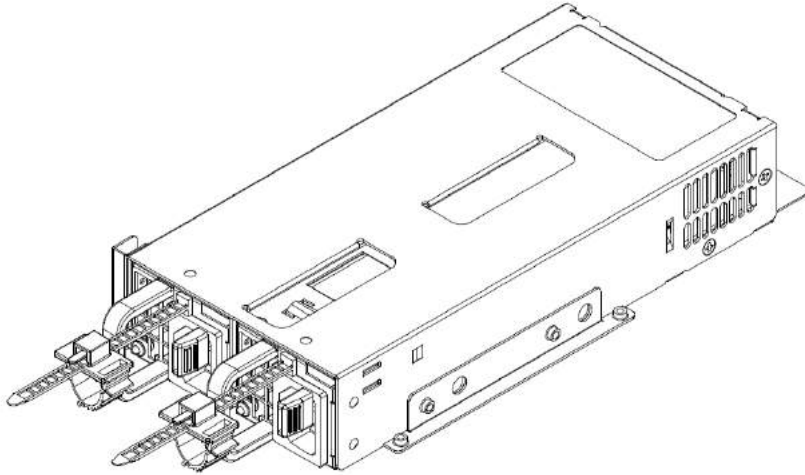

### 12.2 OUTPUT CABLE DIAGRAM

Please refer to detail mechanical drawing

### 12.3 POWER MODULE DIMENSIONS

Dimension (L x W x H): 165 x 50.5 x 40.2mm / 6.50" x 1.99" x 1.59"inch

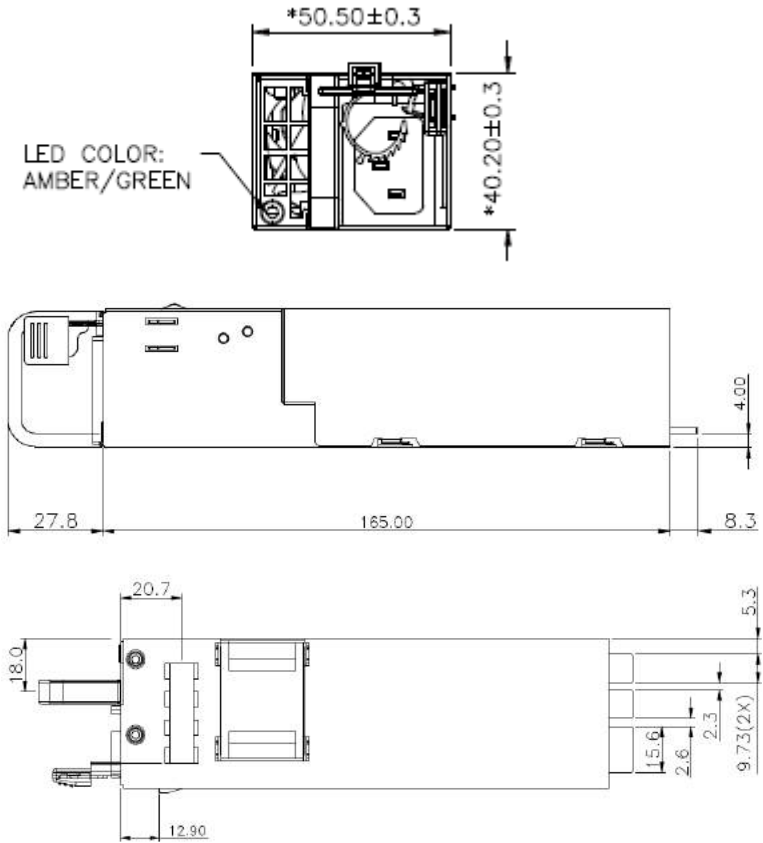

<for reference only, detail drawing MUST use from MO file>



**康舒科技**

ACBEL POLYTECH INC.

# **Mechanical Outline Drawing**

NOTE:

1 ENCLOSURE MATERIAL :  
 SGCC G30/G90(HOT-DIP ZINC-COATED STEEL SHEETS)  
 PRESIDE AND MUST MEET EMC SPEC. 999-999-333  
 FOR HOT-DIP ZINC-COATED STEEL SHEETS (COMPLY  
 WITH ASTM A653 G30). 72 HOURS MINIMUM White  
 RUST PROTECTION IN SALT SPRAY ( ASTM B117),  
 MATERIAL MUST MEET DC RESISTANCE 0.1 OHMS MAX.  
 FOR ELECTRICAL CONDUCTIVITY REQUIREMENTS  
 機殼材質:(熱浸鋅鋼板)G30/G90  
 必須符合EMC 999-999-333 的規範(符合ASTM A653 G30)  
 至少72小時鹽霧防鏽處理( ASTM B117), 材料傳導率DC  
 阻抗需小於 0.1 OHMS MAX

2 ALL EXPOSED EDGES MUST MEET HANDLING  
 REQUIREMENTS SPECIFIED IN UL 1439 AND MUST NOT  
 CUT THROUGH THE FIRST LAYER OF THE TESTER  
 所有可能被觸碰的邊緣必須符合 UL1439 觸摸安全需求,  
 不可以割破檢測物的第一層

3 OPENING IN CHASSIS FOR CABLES TO BE FORMED OR  
 GGROMMET AND SEALED TO PREVENT AIR LEAKAGE  
 AND TO PROTECT CABLES FROM DAMAGE. CABLES TO  
 BE STRAIN RELIEVED  
 輸出線材孔需反摺或設計扣環型式來保護線材,且需避  
 免漏風的情形.線材需消除應力

4 GROUND SYMBOL ⊕ LOCATED TO BE PERMANENTLY  
 MARKED NEAR PRIMARY GROUND CONNECTION.  
 接地符號 ⊕ 需永久的位於一次側接地處

5 BARCODE LABEL, WARNING LABEL AND INFORMATION  
 LABEL LOCATED ON NOTED SURFACE. BEFORE  
 ADHERING LABELS, SHEET METAL SURFACE MUST BE FREE  
 OF ANY GREASE, OIL AND DIRTSHEET METALL SURFACE  
 MUST BE FREE OF ANY GREASE, OIL AND DIRT  
 標籤黏貼的位置如圖示.在黏貼前,金屬表面必須沒有任  
 何的油污,油,或是塵土

6 " \* " CRITICAL DIMENSION. THE FACTORY MUST BE  
 INSPECTED THIS DIMENSION FOR EVERY SHIPMENT.  
 " \* "表示該(尺寸/位置)為設計之重點尺寸,工廠每次出貨  
 貨前必須檢驗合格後,方可出貨

7 DO NOT ALLOW SCRATCH ON THE SURFACE. EXTRUDE  
 PORTION SHOULD PREVENT THE DAMAGE OF THE ZINC  
 PLATED LAYER AND OXIDATION  
 表面不允許刮傷,抽孔擠出成型部份也必須防止電鍍層  
 有氧化現象

8 THE MANUFACTURER SHALL NOTIFY API PRIOR TO  
 CHANGES IN MANUFACTURING LOCATION  
 製造商如需變更製造地,需事先通知API

9 COVER , CHASSIS & SIDE PANEL MUST BE THE SAME  
 COLOR UNLESS OTHERWISE SPECIFIED.  
 除非有特別指示,否則上蓋、下蓋、邊嵌板必須顏色一致

10 NET WEIGHT: 570 GRAMS ±3%  
 淨重: 570 克 ±3%

11 SCREW THREAD MUST BE WITHSTAND THE  
 FOLLOWING TORQUE INDICATED :  
 螺紋鎖付扭轉抗力需大於下列數值:  
 M3 \* 0.5 12Kgf-cm(MIN)  
 M3.5 \* 0.6 15Kgf-cm(MIN)  
 #6-32 12Kgf-cm(MIN)

12 STUD AND CLINCH NUT MUST BE FLUSH ON THE  
 NOTED SURFACE WHICH MUST BE CONFORM TO  
 THE FOLLOWING TORQUE INDICATED :  
 鉚接螺栓或螺帽,需符合下表扭力值:

THREAD CODE 螺紋編號	SHEET THICKNESS 板厚(MM)	SHEET MATERIAL 鋼板材質	
		HOT-DIPPED SHEET 熱浸鋼板	
		PUSHOUT 推出抗力 (Kg-cm MIN)	TORQUE OUT 扭轉抗力 (Kg-cm MIN)
M3 * 0.5	0.8 ~ 1.0	47	15
#6-32		50	18
M4 * 0.7		50	30

13 THIS MATERIAL/PART/ASSEMBLY MUST COMPLY TO  
 ACBEL SPEC "CRITERIA FOR ENVIRONMENT-  
 RELATED SUBSTANCES"  
 材質/零件/製程均必須符合康舒"環境管理物質規範"

14 ALL REF DIMENSIONS MUST COMPLY TO  
 FABRICATE REQUIREMENT  
 所有參考尺寸必須符合實際組裝要求

15 THICKNES: COVER 0.8mm, CHASSIS 0.8mm, BRACKET 0.8mm  
 厚度: 上蓋 0.8mm,下蓋 0.8mm, 支架 0.8mm

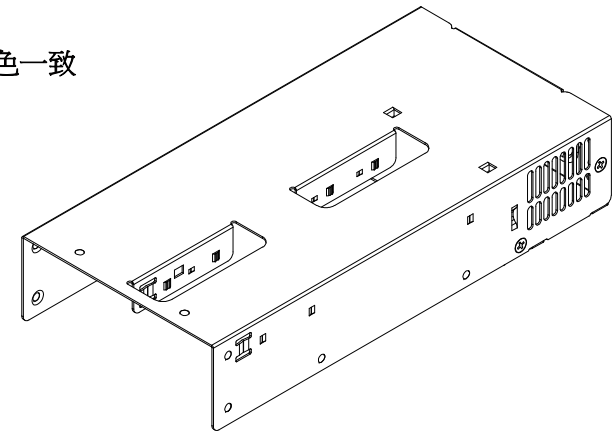

REV	DESCRIPTION	DATE	BY
E	取消支架	02/05/18	MT
D	增加支架&取消4+4P&增加2個小4P	12/25/17	MT
C	取消編織網及PG束線帶	09/08/17	MT
B	修正圖塊	08/07/17	MT
A	RELEASE	07/20/17	MT
1	PRIMARILY	06/15/17	MT

REVISIONS			
MODEL NO. FSD002-4QAG		PART NO. MO-FSD002-4QAG	
ACBEL POLYTECH INC.		DWG NO. MO-FSD002-4QAG_E	
TOLERANCES UNLESS OTHERWISE NOTED ~6:±0.1, 6~120:±0.2, 120~315:±0.3, 315~:±0.5 ANGLES:±0.5°		TITLE: MECHANICAL OUTLINE	
Metric A4	0 mm 25	DESIGNER	MT 02/05/18
THIRD ANGLE PROJECTION		CHECKED	
SCALE: NTS	SHEET 1 OF 3	APPROVED	

RELEASE		
正式發行圖面	REV: E	
ENG. MT	APPR.	

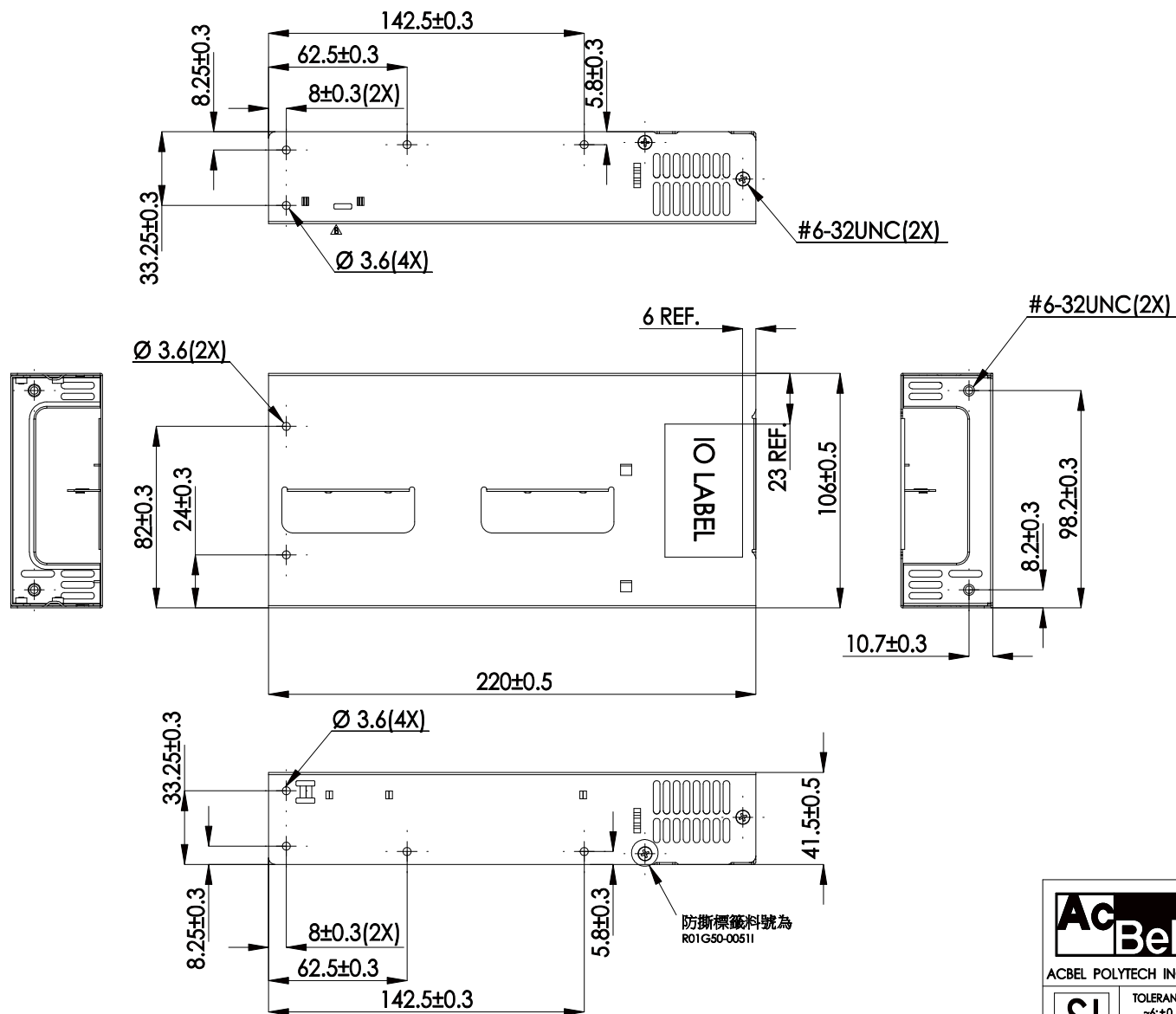

RELEASE  
正式發行圖面 REV: E  
ENG. MT APPR.

 <b>AcBel</b> ACBEL POLYTECH INC.	DRAWINGS & SPEC. ARE THE EXCLUSIVE PROPERTY OF ACBEL POLYTECH INC. SAID ITEMS ARE ISSUED IN STRICT CONFIDENTIAL	
	TOLERANCES UNLESS OTHERWISE NOTED ~6:±0.1, 6~120:±0.2, 120~315:±0.3, 315~:±0.5 ANGLES:±0.5°	MODEL NO. FSD002-4QAG
SI	0 mm 25	
Metric	THIRD ANGLE PROJECTION	
A4	SCALE : NTS SHEET 2 OF 3	
PART NO. MO-FSD002-4QAG		TITLE: MECHANICAL OUTLINE
DWG NO. MO-FSD002-4QAG_E		DESIGNER MT 02/05/18
APPROVED		CHECKED

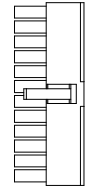
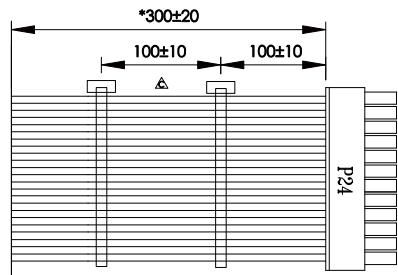

CONN.	PIN	OUTPUT	COLOR	AWG	
P24 MINI-FIT 24PIN	1	+3.3V	ORANGE	18	
	2	+3.3VS	ORANGE	24	
	3	+3.3V	ORANGE	18	
	4	GND	BLACK	18	
	5	+5V	RED	18	
		+5VS	RED	24	
	6	GND	BLACK	18	
	7	RS-GND	BLACK	24	
	8	+5V	RED	18	
	9	GND	BLACK	18	
	10	+12V	YELLOW	18	
		+12VS	YELLOW	24	
	11	+12V	YELLOW	18	
	12	+3.3V	ORANGE	18	
	13	+3.3V	ORANGE	18	
	14	-12V	BLUE	18	
	15	GND	BLACK	18	
	16	PS_ON	GREEN	24	
	17	GND	BLACK	18	
	18	GND	BLACK	18	
	19	GND	BLACK	18	
	20				
	21	+5V	RED	18	
	22	+5V	RED	18	
23	+5V	RED	18		
24	GND	BLACK	18		

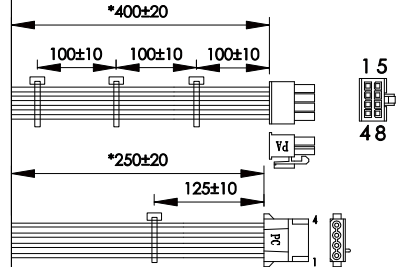
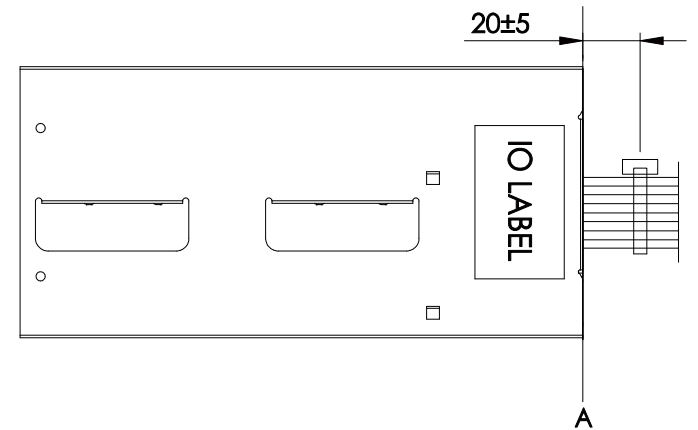

CONN.	PIN	OUTPUT	COLOR	AWG
PA MINI-FIT 8PIN	1	GND	BLACK	18
	2	GND	BLACK	18
	3	GND	BLACK	18
	4	GND	BLACK	18
	5	+12V	YELLOW	18
	6	+12V	YELLOW	18
	7	+12V	YELLOW	18
	8	+12V	YELLOW	18

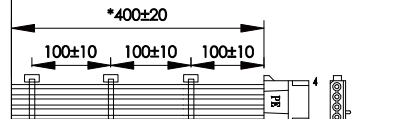
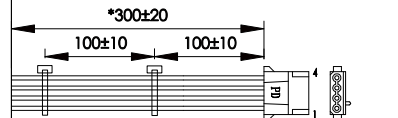

CONN.	PIN	OUTPUT	COLOR	AWG
PC-PF L4P	1	+12V	YELLOW	18
	2	GND	BLACK	18
	3	GND	BLACK	18
	4	+5V	RED	18

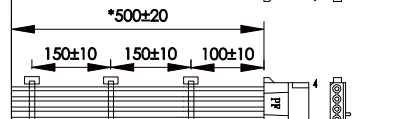

CONN.	PIN	OUTPUT	COLOR	AWG
PG PMBUS	1	12CSCL	WHT/GRN	24
	2	12CSDA	WHT/YEL	24
	3	PS_Alert	WHITE	24
	4	GND	BLACK	24
	5			

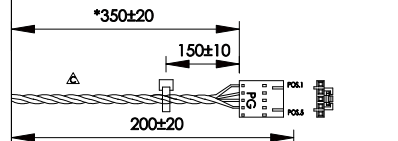

CONN.	PIN	OUTPUT	COLOR	AWG
MUTE	1	GND	BLK	26
	2	BUZZER_RESET	YELLOW	26

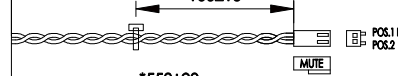

PG:1 BLACK  
PG:2 YELLOW MUTE

CONN.	PIN	OUTPUT	COLOR	AWG
PH/PI FDD	1	+5V	RED	22
	2	GND	BLACK	22
	3	GND	BLACK	22
	4	+12V	YELLOW	22

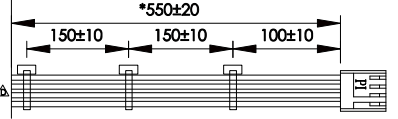
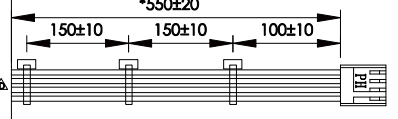

RELEASE  
正式發行圖面 REV: E  
ENG. MT APPR.

 ACBEL POLYTECH INC.	DRAWINGS & SPEC. ARE THE EXCLUSIVE PROPERTY OF ACBEL POLYTECH INC. SAID ITEMS ARE ISSUED IN STRICT CONFIDENTIAL	MODEL NO. FSD002-4QAG
		PART NO. MO-FSD002-4QAG
 TOLERANCES UNLESS OTHERWISE NOTED ~6:±0.1, 6~120: ±0.2, 120~315: ±0.3, 315~:±0.5 ANGLES: ±0.5°	 THIRD ANGLE PROJECTION	DWG NO. MO-FSD002-4QAG_E
		TITLE: MECHANICAL OUTLINE
SCALE: NTS	SHEET 3 OF 3	DESIGNER MT 02/05/18
		CHECKED
		APPROVED



**康舒科技**

ACBEL POLYTECH INC.

# I/O Label Drawing

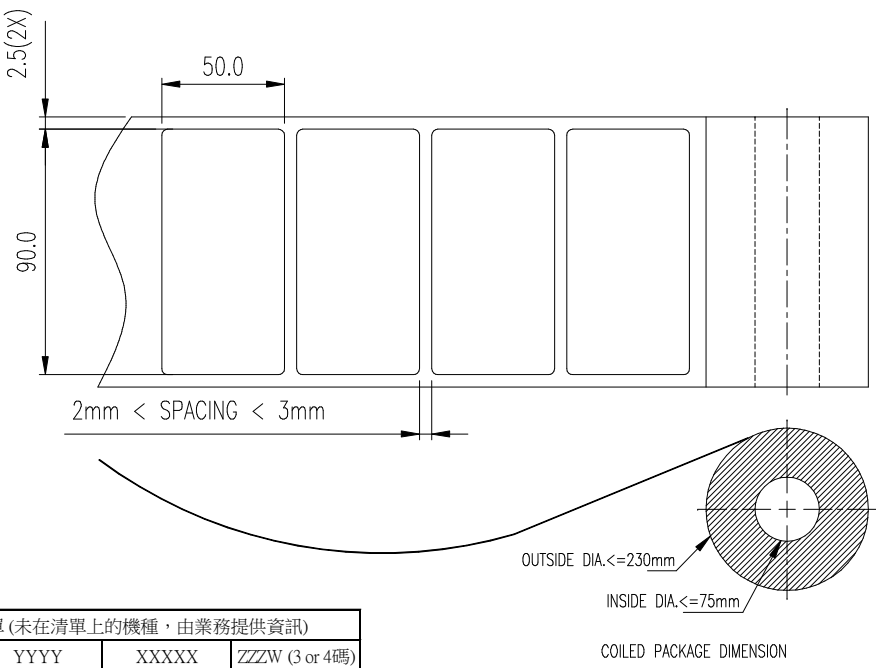
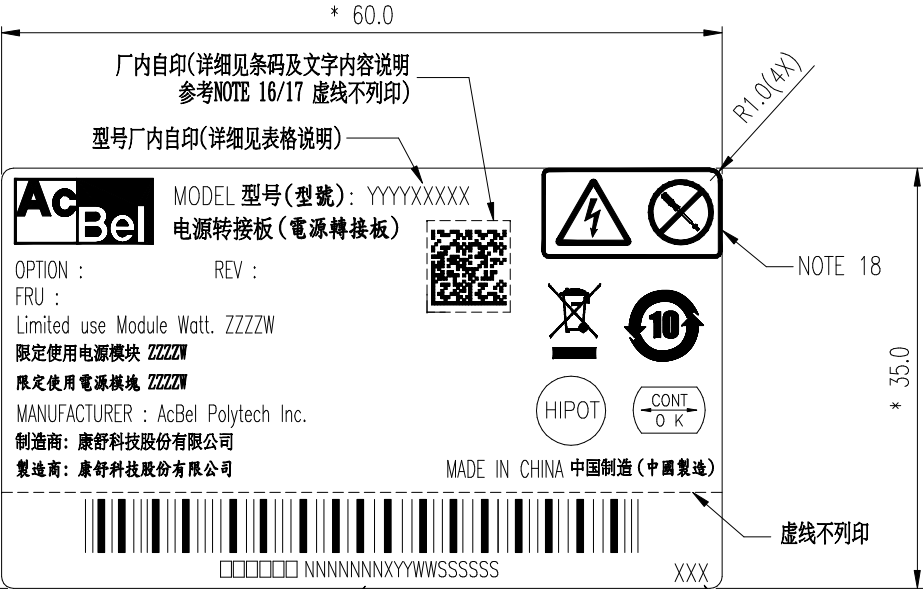

ZZZZW 厂内套印  
(详见表格说明)

厂内自印 NOTE 11  
(同SN字印原则)

NOTE 18

NOTE 7

虚线不列印

OUTSIDE DIA. <= 230mm  
INSIDE DIA. <= 75mm  
COILED PACKAGE DIMENSION

機種對應清單 (未在清單上的機種, 由業務提供資訊)

機種名稱	YYYY	XXXXX	ZZZW (3 or 4碼)
FSB029	R2IU	7551A	549W
FSD007		7651A	650W
FSC046		7771A	775W
FSC043		7871A	875W
FSC054		7971A	975W
FSD013		7112A	1100W
FSB018	R2CU	6551A	550W
PBC002	R1BU	6651A	650W
FSE035		6451A	450W

RELEASE	
正式發行圖面	REV: B
ENG. Ting	APPR.

SN自印原则:

1 2 3 4 5 6 7 8 9 10 11 12 13 14 15 16 17 18 19 20 21 22 23 24

□ □ □ □ □ N N N N N N X Y Y W W S S S S S S

SERIAL NO 000001-999999

DATE CODE (YY : YEAR WW:WEEK  
FOR EXAMPLE : 2012 13TH WEEK 则此4栏位为"1213")

MFG. FACTORY CODE:  
(东莞康舒印: B ; 东莞康展印: T ; 武汉康舒印: W )

ID CODE (Ex. : 若机种FSA035-001G印001G)

API REVISION CONTROL CODE (S1印: 0S1 ; S2印: 0S2 ; A印: A00)

API MODEL NAME (Ex. : 若机种FSA035-001G, 则印制" FSA035"于此6个栏位)

B	MODIFY LABEL FORMAT	TING	09/23/14
A	RELEASE	TING	06/05/14
1	PRIMARILY	TING	01/21/14
REV	DESCRIPTION	BY	DATE
		MODEL NO. FSC043-7EFG	
ACBEL POLYTECH INC.		PART NO. X01AAA-7100IA	
		DWG. NO : X01AAA-7100IA_B	
		TITLE	
I/O LABEL		DESIGNER	TING 09/23/14
SCALE NONE		CHECKED	
SHEET 1 OF 2		APPROVED	

NOTES:

- UNIT : MM.  
单位 : 毫米.
- MATERIAL :
  - FACE STOCK 底材 :  
WHITE POLYESTER, THICKNESS = 0.05 MM.  
白色麦拉片, 厚度= 0.05毫米
  - OVERLAMINATION 保护膜 :  
 A TRANSPARENT FILM 透明胶膜  NONE 无
  - ADHESIVE 背胶 : PRESSURE SENSITIVE ACRYLIC 压克力压膜胶  
THICKNESS 厚度 = 0.025 MM
  - BACKED WITH RELEASE LINER. 背面附离型纸
  - LABEL TO BE AFFIXED TO AND MAXIMUM TEMPERATURE RATING 贴纸所贴附之材质与最大耐温等级 :  
 GALVANIZED STEEL 镀锌钢  ALUMINUM 铝  
 NICKEL PLATED METAL 镀镍金属  
 ZINC PLATED METAL WITH CHROMATE POST TREATMENT 后处理之镀铬酸锌金属  
 100°C 摄氏100度
  - MATERIAL MUST BE UL RECOGNIZED AND COMPLY TO UL 969 STANDARD.  
材质必须符合 UL 认证, 并且遵从 UL 969 标准.
- LABEL MUST BE MADE BY A UL RECOGNIZED AND CSA APPROVED VENDOR.  
贴纸之制造商必须是 UL 与 CSA 所认证.
- TOLERANCE : XX = +/- 0.5    XX.X = +/- 0.2  
                  XX.XX = +/- 0.15  
公差 : XX = +/- 0.5    XX.X = +/- 0.2  
                  XX.XX = +/- 0.15
- "\*" CRITICAL DIMENSION SYMBOL, SUPPLIER MUST INSPECT THIS DIMENSION FOR EVERY SHIPMENT  
"\*" 表示该(尺寸/位置)为设计之重点尺寸, 供应商每次出货前必须检验合格后, 方可出货.
- ALL PRODUCTS MUST BE THE SAME AS ENGINEERING API MECHANICAL ENGINEERING APPROVED SAMPLES, ANY MODIFICATION MUST BE APPROVED BY ACBEL MECHANICAL ENGINEERING SECTION.  
所有产品必须与认可的样品一致, 任何的修改都必须经由康舒机构工程师同意及认可.
- LABEL MUST CONTAIN THE VENDOR'S ID MARK LOCATED IN THE AREA INDICATED. ID MARK LETTER HEIGHT TO BE 1.5MM.  
贴纸必须印制厂商代码, 代码字高为 5 毫米.
- CHARACTER HEIGHT : 1.5 MM , UNLESS OTHERWISE SPECIFIED.  
图面未标示之字体高度皆为 1.5 毫米
- PRINTED COLOR :  
BLACK - TEXT, GRAPHICS, IMAGE, LOGO SURROUND SHAPE.  
WHITE - BACKGROUND.  
列印颜色 :  
黑色 - 文字、图形、图象、标志、外围图形      白色 - 背景

- THESE MATERIAL/PART/ASSEMBLY MUST COMPLY TO ACBEL SPEC"CRITERIA FOR ENVIRONMENT-RELATED SUBSTANCES".  
材质/零件/制程均必须符合康舒"环境管理物质规范".
- BAR CODE FORMAT: CODE 128 / CPI : 13.64  
THE NARROW ELEMENT DIMENSION (X DIMENSION) SHOULD BE WITHIN A RANGE OF 0.170MM(0.0067 INCH)  
条码格式 : CODE 128 / CPI 13.64 宽/窄比 : 0.17毫米(0.0067英寸)
- BAR CODE & SN & FRU 厂内自印
- REV : XXX (S1印 : 0S1 ; S2印 : 0S2 ; A印 : A00)
- DATE : XYYWW 为厂内自印, 4码 YYWW为制造周期, X为工厂代码\*  
工厂代码 : 康舒东莞厂印B, 康展东莞厂印T, 康舒武汉厂印W
- FRU自印原则

AXXSS□□□□□

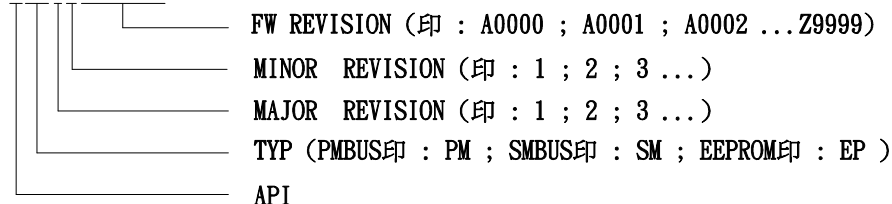

16. 条码自印原则

XXXXXXXXXXXXX;OOOOONNNNNNNXYYWSSSSSS;YYMMDD;XXXXXXXXXX

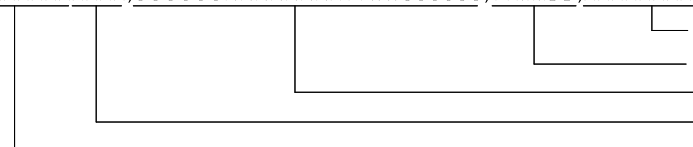

17. 条码及文字内容说明

编码: DATAMATRIX

18. 警告符号颜色定义如下:

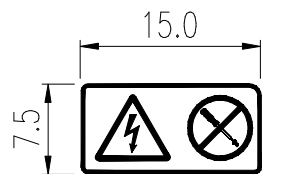

底色: PANTONE 108C  
图形: PANTONE Black C

RELEASE		
正式發行圖面	REV: B	
ENG. Ting	APPR.	

	MODEL NO. FSC043-7EFG
	PART NO. X01AAA-7100IA
ACBEL POLYTECH INC.	DWG. NO : X01AAA-7100IA_B
	TITLE I/O LABEL
	DESIGNER TING 09/23/14
SCALE NONE SHEET 2 OF 2	CHECKED
	APPROVED



# 康舒科技

ACBEL POLYTECH INC.

**AcBel** MODEL 型号(型号): R1BU5301B  
电源转接板(电源转接板)

OPTION : G4QA REV : A02  
FRU : APM12V0308

Limited use Module Watt. 300W  
限定使用电源模块 300W  
限定使用电源模块 300W

MANUFACTURER : AcBel Polytech Inc.  
制造商: 康舒科技股份有限公司  
製造商: 康舒科技股份有限公司

MADE IN CHINA 中国制造(中国製造)

FSD002A024QAGB174500008





**康舒科技**

ACBEL POLYTECH INC.

# **ATE Test Report**





Dynamic Load Response									
Input	Output			Test Limits		Test Results		Pass / Fail	Remarks
Volt	Volt	Load 1	Load 2	Min	Max	Min	Max		
90.000	+5V	12.600	0.100	4.750	5.250	4.906	4.954	PASS	90V +5V Low Step * 50Hz
	+3.3V	0.100	0.100						
	-12V	0.000	0.000						
	+5Vs b	0.000	0.000						
	+12V	0.000	0.000						
90.000	+5V	18.000	5.500	4.750	5.250	4.877	4.951	PASS	90V +5V High Step * 50Hz
	+3.3V	0.500	0.500						
	-12V	0.300	0.300						
	+5Vs b	2.500	2.500						
	+12V	16.020	16.020						
264.000	+5V	12.600	0.100	4.750	5.250	4.909	4.954	PASS	264V +5V Low Step * 50Hz
	+3.3V	0.100	0.100						
	-12V	0.000	0.000						
	+5Vs b	0.000	0.000						
	+12V	0.000	0.000						
264.000	+5V	18.000	5.500	4.750	5.250	4.880	4.951	PASS	264V +5V High Step * 50Hz
	+3.3V	0.500	0.500						
	-12V	0.300	0.300						
	+5Vs b	2.500	2.500						
	+12V	16.020	16.020						
90.000	+5V	12.600	0.100	4.750	5.250	4.907	4.949	PASS	90V +5V Low Step * 5kHz
	+3.3V	0.100	0.100						
	-12V	0.000	0.000						
	+5Vs b	0.000	0.000						
	+12V	0.000	0.000						
90.000	+5V	18.000	5.500	4.750	5.250	4.891	4.946	PASS	90V +5V High Step * 5kHz
	+3.3V	0.500	0.500						
	-12V	0.300	0.300						
	+5Vs b	2.500	2.500						
	+12V	16.020	16.020						

264.00 0	+5V	12.60 0	0.100	4.750	5.250	4.907	4.949	PASS	264V +5V Low Step * 5kHz
	+3.3 V	0.100	0.100						
	-12V	0.000	0.000						
	+5Vs b	0.000	0.000						
	+12V	0.000	0.000						
264.00 0	+5V	18.00 0	5.500	4.750	5.250	4.879	4.947	PASS	264V +5V High Step * 5kHz
	+3.3 V	0.500	0.500						
	-12V	0.300	0.300						
	+5Vs b	2.500	2.500						
	+12V	16.02 0	16.02 0						
90.000	+5V	0.100	0.100	3.130	3.470	3.256	3.297	PASS	90V +3.3V Low Step * 50Hz
	+3.3 V	10.50 0	0.100						
	-12V	0.000	0.000						
	+5Vs b	0.000	0.000						
	+12V	0.000	0.000						
90.000	+5V	8.480	8.480	3.130	3.470	3.228	3.274	PASS	90V +3.3V High Step * 50Hz
	+3.3 V	15.00 0	4.600						
	-12V	0.300	0.300						
	+5Vs b	2.500	2.500						
	+12V	16.02 0	16.02 0						
264.00 0	+5V	0.100	0.100	3.130	3.470	3.258	3.296	PASS	264V +3.3V Low Step * 50Hz
	+3.3 V	10.50 0	0.100						
	-12V	0.000	0.000						
	+5Vs b	0.000	0.000						
	+12V	0.000	0.000						
264.00 0	+5V	8.480	8.480	3.130	3.470	3.230	3.273	PASS	264V +3.3V High Step * 50Hz
	+3.3 V	15.00 0	4.600						
	-12V	0.300	0.300						
	+5Vs b	2.500	2.500						
	+12V	16.02 0	16.02 0						
90.000	+5V	0.100	0.100	3.130	3.470	3.254	3.301	PASS	90V +3.3V Low Step * 5kHz
	+3.3 V	10.50 0	0.100						
	-12V	0.000	0.000						
	+5Vs b	0.000	0.000						
	+12V	0.000	0.000						
90.000	+5V	8.480	8.480	3.130	3.470	3.225	3.280	PASS	90V +3.3V
	+3.3	15.00	4.600						

	V	0							High Step * 5kHz
	-12V	0.300	0.300						
	+5Vs b	2.500	2.500						
	+12V	16.02 0	16.02 0						
264.00 0	+5V	0.100	0.100	3.130	3.470	3.254	3.301	PASS	264V +3.3V Low Step * 5kHz
	+3.3 V	10.50 0	0.100						
	-12V	0.000	0.000						
	+5Vs b	0.000	0.000						
	+12V	0.000	0.000						
264.00 0	+5V	8.480	8.480	3.130	3.470	3.226	3.280	PASS	264V +3.3V High Step * 5kHz
	+3.3 V	15.00 0	4.600						
	-12V	0.300	0.300						
	+5Vs b	2.500	2.500						
	+12V	16.02 0	16.02 0						
90.000	+5V	0.100	0.100	4.750	5.250	4.886	5.147	PASS	90V +5VSB Low Step * 50Hz
	+3.3 V	0.100	0.100						
	-12V	0.000	0.000						
	+5Vs b	1.750	0.000						
	+12V	0.000	0.000						
90.000	+5V	18.00 0	18.00 0	4.750	5.250	4.846	4.991	PASS	90V +5VSB High Step * 50Hz
	+3.3 V	0.500	0.500						
	-12V	0.300	0.300						
	+5Vs b	2.500	0.750						
	+12V	16.02 0	16.02 0						
264.00 0	+5V	0.100	0.100	4.750	5.250	4.885	5.145	PASS	264V +5VSB Low Step * 50Hz
	+3.3 V	0.100	0.100						
	-12V	0.000	0.000						
	+5Vs b	1.750	0.000						
	+12V	0.000	0.000						
264.00 0	+5V	18.00 0	18.00 0	4.750	5.250	4.846	4.991	PASS	264V +5VSB High Step * 50Hz
	+3.3 V	0.500	0.500						
	-12V	0.300	0.300						
	+5Vs b	2.500	0.750						
	+12V	16.02 0	16.02 0						
90.000	+5V	0.100	0.100	4.750	5.250	4.922	5.125	PASS	90V +5VSB Low
	+3.3 V	0.100	0.100						

	-12V	0.000	0.000						Step * 5kHz
	+5Vs b	1.750	0.000						
	+12V	0.000	0.000						
90.000	+5V	18.00 0	18.00 0	4.750	5.250	4.846	4.987	PASS	90V +5VSB High Step * 5kHz
	+3.3 V	0.500	0.500						
	-12V	0.300	0.300						
	+5Vs b	2.500	0.750						
	+12V	16.02 0	16.02 0						
264.00 0	+5V	0.100	0.100	4.750	5.250	4.923	5.127	PASS	264V +5VSB Low Step * 5kHz
	+3.3 V	0.100	0.100						
	-12V	0.000	0.000						
	+5Vs b	1.750	0.000						
	+12V	0.000	0.000						
264.00 0	+5V	18.00 0	18.00 0	4.750	5.250	4.846	4.988	PASS	264V +5VSB High Step * 5kHz
	+3.3 V	0.500	0.500						
	-12V	0.300	0.300						
	+5Vs b	2.500	0.750						
	+12V	16.02 0	16.02 0						
90.000	+5V	0.100	0.100	11.40 0	12.60 0	11.76 3	12.29 5	PASS	90V +12V1 Low Step * 50Hz
	+3.3 V	0.100	0.100						
	-12V	0.000	0.000						
	+5Vs b	0.000	0.000						
	+12V	16.80 0	0.000						
90.000	+5V	1.730	1.730	11.40 0	12.60 0	11.94 9	12.29 2	PASS	90V +12V1 High Step * 50Hz
	+3.3 V	0.500	0.500						
	-12V	0.100	0.100						
	+5Vs b	0.100	0.100						
	+12V	24.00 0	7.200						
264.00 0	+5V	0.100	0.100	11.40 0	12.60 0	11.87 9	12.33 8	PASS	264V +12V1 Low Step * 50Hz
	+3.3 V	0.100	0.100						
	-12V	0.000	0.000						
	+5Vs b	0.000	0.000						
	+12V	16.80 0	0.000						
264.00 0	+5V	1.730	1.730	11.40 0	12.60 0	11.96 8	12.29 3	PASS	264V +12V1 High
	+3.3 V	0.500	0.500						



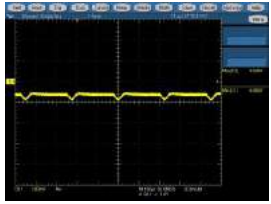
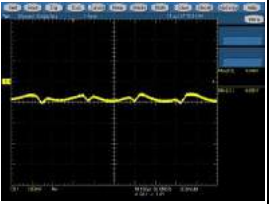
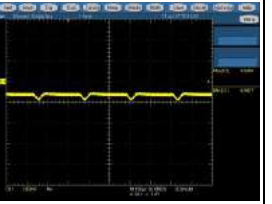
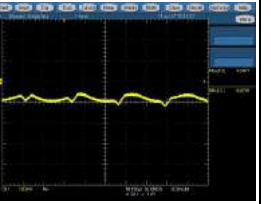

	-12V	0.100	0.100							Step * 50Hz
	+5Vs b	0.100	0.100							
	+12V	24.00 0	7.200							
90.000	+5V	0.100	0.100	11.40 0	12.60 0	12.06 8	12.22 8	PASS	90V +12V1 Low Step * 5kHz	
	+3.3 V	0.100	0.100							
	-12V	0.000	0.000							
	+5Vs b	0.000	0.000							
	+12V	16.80 0	0.000							
90.000	+5V	1.730	1.730	11.40 0	12.60 0	12.06 7	12.23 1	PASS	90V +12V1 High Step * 5kHz	
	+3.3 V	0.500	0.500							
	-12V	0.100	0.100							
	+5Vs b	0.100	0.100							
	+12V	24.00 0	7.200							
264.00 0	+5V	0.100	0.100	11.40 0	12.60 0	12.06 6	12.21 8	PASS	264V +12V1 Low Step * 5kHz	
	+3.3 V	0.100	0.100							
	-12V	0.000	0.000							
	+5Vs b	0.000	0.000							
	+12V	16.80 0	0.000							
264.00 0	+5V	1.730	1.730	11.40 0	12.60 0	12.06 3	12.22 5	PASS	264V +12V1 High Step * 5kHz	
	+3.3 V	0.500	0.500							
	-12V	0.100	0.100							
	+5Vs b	0.100	0.100							
	+12V	24.00 0	7.200							

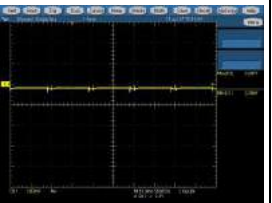
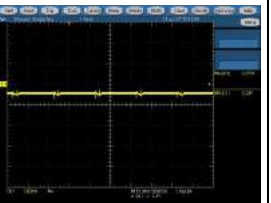
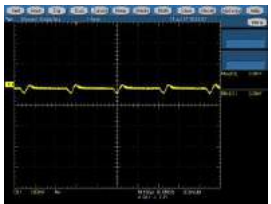
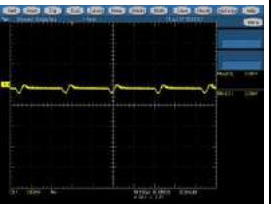
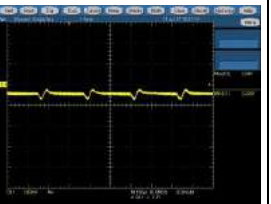
			
90V +5V Low Step * 50Hz CH1:+5V	90V +5V High Step * 50Hz CH1:+5V	264V +5V Low Step * 50Hz CH1:+5V	264V +5V High Step * 50Hz CH1:+5V

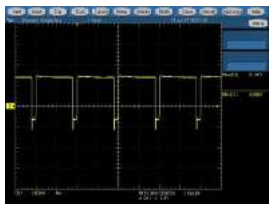
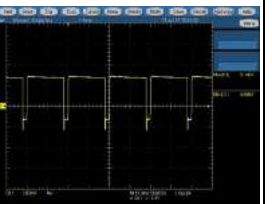
			
90V +5V Low Step * 5kHz CH1:+5V	90V +5V High Step * 5kHz CH1:+5V	264V +5V Low Step * 5kHz CH1:+5V	264V +5V High Step * 5kHz CH1:+5V

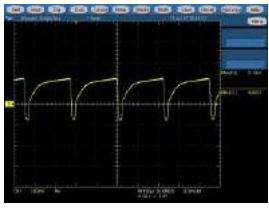

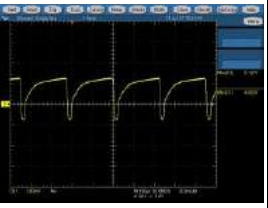

			
90V +3.3V Low Step * 50Hz CH1:+3.3V	90V +3.3V High Step * 50Hz CH1:+3.3V	264V +3.3V Low Step * 50Hz CH1:+3.3V	264V +3.3V High Step * 50Hz CH1:+3.3V
			
90V +3.3V Low Step * 5kHz CH1:+3.3V	90V +3.3V High Step * 5kHz CH1:+3.3V	264V +3.3V Low Step * 5kHz CH1:+3.3V	264V +3.3V High Step * 5kHz CH1:+3.3V

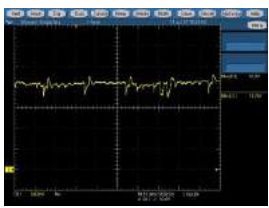
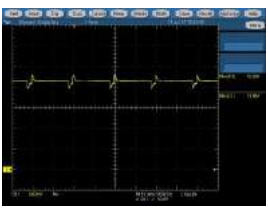
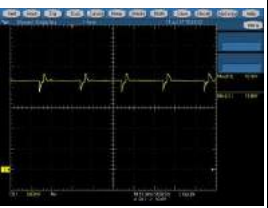
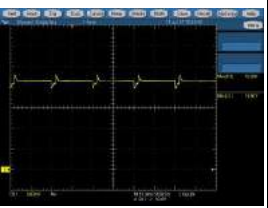
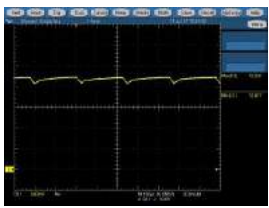
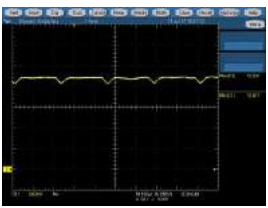
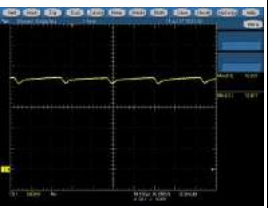
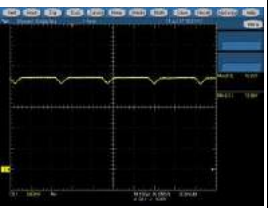

			
90V +5VSB Low Step * 50Hz CH1:+5VSB	90V +5VSB High Step * 50Hz CH1:+5VSB	264V +5VSB Low Step * 50Hz CH1:+5VSB	264V +5VSB High Step * 50Hz CH1:+5VSB

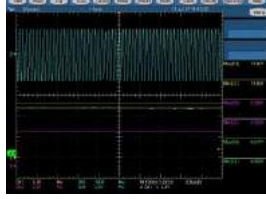
			
90V +5VSB Low Step * 5kHz CH1:+5VSB	90V +5VSB High Step * 5kHz CH1:+5VSB	264V +5VSB Low Step * 5kHz CH1:+5VSB	264V +5VSB High Step * 5kHz CH1:+5VSB

			
90V +12V1 Low Step * 50Hz CH1:+12V1	90V +12V1 High Step * 50Hz CH1:+12V1	264V +12V1 Low Step * 50Hz CH1:+12V1	264V +12V1 High Step * 50Hz CH1:+12V1
			
90V +12V1 Low Step * 5kHz CH1:+12V1	90V +12V1 High Step * 5kHz CH1:+12V1	264V +12V1 Low Step * 5kHz CH1:+12V1	264V +12V1 High Step * 5kHz CH1:+12V1

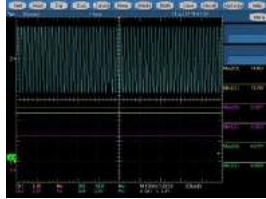
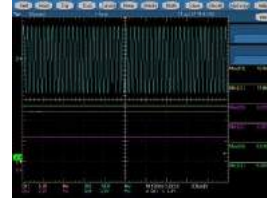
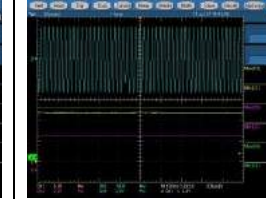
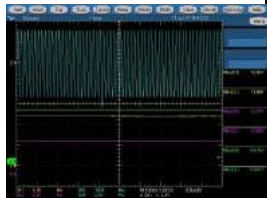
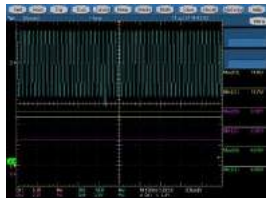
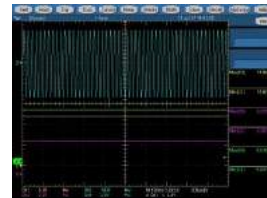
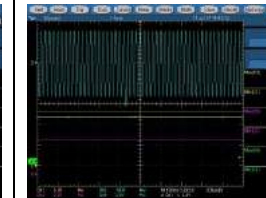

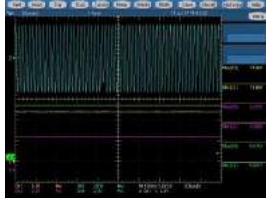
Over Current Protection								
Input		Output		Test Limits		Test Results	Pass / Fail	Remarks
Volt	Freq	Volt	Load	Min	Max			
90.000	47.000	+5V	0.500	19.800	27.000	21.400	PASS	90V +5V
		+3.3V	0.500					
		-12V	0.100					
		+5Vsb	0.100					
		+12V	0.500					
264.000	63.000	+5V	0.500	19.800	27.000	21.400	PASS	264V +5V
		+3.3V	0.500					
		-12V	0.100					
		+5Vsb	0.100					
		+12V	0.500					
90.000	47.000	+5V	0.500	16.500	22.500	22.400	PASS	90V +3.3V
		+3.3V	0.500					
		-12V	0.100					
		+5Vsb	0.100					
		+12V	0.500					
264.000	63.000	+5V	0.500	16.500	22.500	22.400	PASS	264V +3.3V
		+3.3V	0.500					
		-12V	0.100					
		+5Vsb	0.100					
		+12V	0.500					
90.000	47.000	+5V	0.500	2.750	3.750	2.850	PASS	90V +5VSB
		+3.3V	0.500					
		-12V	0.100					
		+5Vsb	0.100					
		+12V	0.500					
264.000	63.000	+5V	0.500	2.750	3.750	2.850	PASS	264V +5VSB
		+3.3V	0.500					
		-12V	0.100					
		+5Vsb	0.100					
		+12V	0.500					
90.000	47.000	+5V	0.500	26.400	36.000	26.500	PASS	90V +12V1
		+3.3V	0.500					
		-12V	0.100					
		+5Vsb	0.100					
		+12V	0.500					
264.000	63.000	+5V	0.500	26.400	36.000	26.500	PASS	264V +12V1
		+3.3V	0.500					
		-12V	0.100					
		+5Vsb	0.100					
		+12V	0.500					

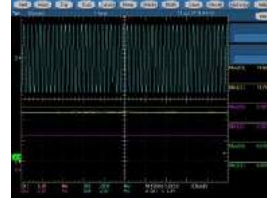
			
90V-10%-16ms-Min CH1:+12V1 , CH2:Vin , CH3: PG , CH4:+5V	90V-10%-16ms-Max CH1:+12V1 , CH2:Vin , CH3: PG , CH4:+5V	90V-10%-20ms-Min CH1:+12V1 , CH2:Vin , CH3: PG , CH4:+5V	90V-10%-20ms-Max CH1:+12V1 , CH2:Vin , CH3: PG , CH4:+5V
			
115V-30%-8ms-Min CH1:+12V1 , CH2:Vin , CH3: PG , CH4:+5V	115V-30%-8ms-Max CH1:+12V1 , CH2:Vin , CH3: PG , CH4:+5V	115V-30%-10ms-Min CH1:+12V1 , CH2:Vin , CH3: PG , CH4:+5V	115V-30%-10ms-Max CH1:+12V1 , CH2:Vin , CH3: PG , CH4:+5V
			
115V+30%-8ms-Min CH1:+12V1 , CH2:Vin , CH3: PG , CH4:+5V	115V+30%-8ms-Max CH1:+12V1 , CH2:Vin , CH3: PG , CH4:+5V	115V+30%-10ms-Min CH1:+12V1 , CH2:Vin , CH3: PG , CH4:+5V	115V+30%-10ms-Max CH1:+12V1 , CH2:Vin , CH3: PG , CH4:+5V

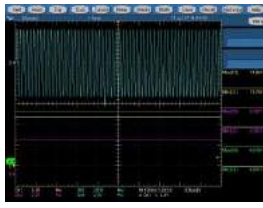
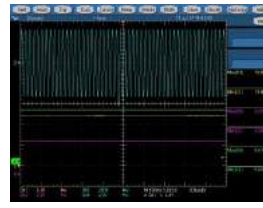
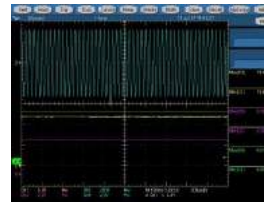
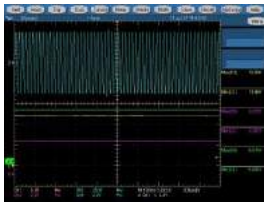
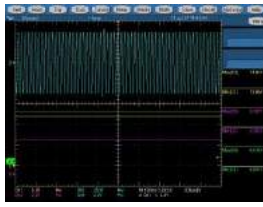
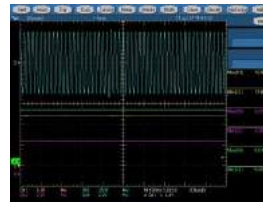
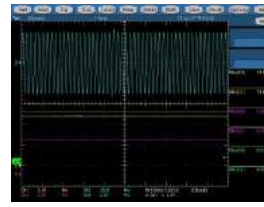
			
230V-30%-8ms-Min	230V-30%-8ms-Max	230V-30%-10ms-Min	230V-30%-10ms-Max

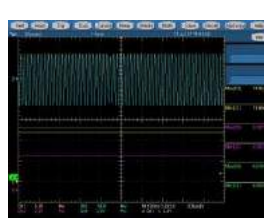
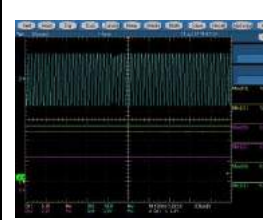
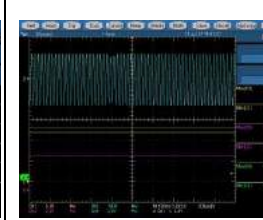
CH1:+12V1 , CH2:Vin , CH3: PG , CH4:+5V	CH1:+12V1 , CH2:Vin , CH3: PG , CH4:+5V	CH1:+12V1 , CH2:Vin , CH3: PG , CH4:+5V	CH1:+12V1 , CH2:Vin , CH3: PG , CH4:+5V
			
230V+30%-8ms-Min CH1:+12V1 , CH2:Vin , CH3: PG , CH4:+5V	230V+30%-8ms-Max CH1:+12V1 , CH2:Vin , CH3: PG , CH4:+5V	230V+30%-10ms-Min CH1:+12V1 , CH2:Vin , CH3: PG , CH4:+5V	230V+30%-10ms-Max CH1:+12V1 , CH2:Vin , CH3: PG , CH4:+5V
			
264V+10%-16ms-Min CH1:+12V1 , CH2:Vin , CH3: PG , CH4:+5V	264V+10%-16ms-Max CH1:+12V1 , CH2:Vin , CH3: PG , CH4:+5V	264V+10%-20ms-Min CH1:+12V1 , CH2:Vin , CH3: PG , CH4:+5V	264V+10%-20ms-Max CH1:+12V1 , CH2:Vin , CH3: PG , CH4:+5V

			
90V-11%-24ms-Min CH1:+12V1 , CH2:Vin , CH3: PG , CH4:+5V	90V-11%-24ms-Max CH1:+12V1 , CH2:Vin , CH3: PG , CH4:+5V	90V-11%-30ms-Min CH1:+12V1 , CH2:Vin , CH3: PG , CH4:+5V	90V-11%-30ms-Max CH1:+12V1 , CH2:Vin , CH3: PG , CH4:+5V

			
115V-100%-16ms- Min CH1:+12V1 , CH2:Vin , CH3: PG , CH4:+5V	115V-100%-16ms- Max CH1:+12V1 , CH2:Vin , CH3: PG , CH4:+5V	115V-100%-20ms- Min CH1:+12V1 , CH2:Vin , CH3: PG , CH4:+5V	115V-100%-20ms- Max CH1:+12V1 , CH2:Vin , CH3: PG , CH4:+5V
			
230V-100%-16ms- Min CH1:+12V1 , CH2:Vin , CH3: PG , CH4:+5V	230V-100%-16ms- Max CH1:+12V1 , CH2:Vin , CH3: PG , CH4:+5V	230V-100%-20ms- Min CH1:+12V1 , CH2:Vin , CH3: PG , CH4:+5V	230V-100%-20ms- Max CH1:+12V1 , CH2:Vin , CH3: PG , CH4:+5V

Ripple & Noise							
Input		Output		Max_Spec	Test Results	Pass / Fail	Remarks
Volt	Freq	Volt	Load				
90.000	47.000	+5V	0.500	50.000	26.000	PASS	90V +5V min
		+3.3V	0.500				
		-12V	0.100				
		+5Vsb	0.100				
		+12V	0.500				
90.000	47.000	+5V	18.000	50.000	40.800	PASS	90V +5V max
		+3.3V	0.500				
		-12V	0.300				
		+5Vsb	2.500				
		+12V	16.020				
264.000	63.000	+5V	0.500	50.000	27.600	PASS	264V +5V min
		+3.3V	0.500				
		-12V	0.100				
		+5Vsb	0.100				
		+12V	0.500				
264.000	63.000	+5V	18.000	50.000	42.400	PASS	264V +5V max
		+3.3V	0.500				
		-12V	0.300				
		+5Vsb	2.500				
		+12V	16.020				
90.000	47.000	+5V	0.500	50.000	13.600	PASS	90V +3.3V min
		+3.3V	0.500				
		-12V	0.100				
		+5Vsb	0.100				
		+12V	0.500				
90.000	47.000	+5V	8.480	50.000	15.200	PASS	90V +3.3V max
		+3.3V	15.000				
		-12V	0.300				
		+5Vsb	2.500				
		+12V	16.020				
264.000	63.000	+5V	0.500	50.000	13.600	PASS	264V +3.3V min
		+3.3V	0.500				
		-12V	0.100				
		+5Vsb	0.100				
		+12V	0.500				
264.000	63.000	+5V	8.480	50.000	14.800	PASS	264V +3.3V max
		+3.3V	15.000				
		-12V	0.300				
		+5Vsb	2.500				
		+12V	16.020				
90.000	47.000	+5V	0.500	50.000	6.800	PASS	90V +5VSB min
		+3.3V	0.500				
		-12V	0.100				
		+5Vsb	0.100				
		+12V	0.500				
90.000	47.000	+5V	18.000	50.000	12.000	PASS	90V +5VSB max
		+3.3V	0.500				
		-12V	0.300				
		+5Vsb	2.500				
		+12V	16.020				
264.000	63.000	+5V	0.500	50.000	6.800	PASS	264V

		+3.3V	0.500				+5VSB min
		-12V	0.100				
		+5Vsb	0.100				
		+12V	0.500				
264.000	63.000	+5V	18.000	50.000	13.200	PASS	264V +5VSB max
		+3.3V	0.500				
		-12V	0.300				
		+5Vsb	2.500				
		+12V	16.020				
90.000	47.000	+5V	0.500	120.000	28.800	PASS	90V +12V1 min
		+3.3V	0.500				
		-12V	0.100				
		+5Vsb	0.100				
		+12V	0.500				
90.000	47.000	+5V	1.730	120.000	32.800	PASS	90V +12V1 max
		+3.3V	0.500				
		-12V	0.100				
		+5Vsb	0.100				
		+12V	24.000				
264.000	63.000	+5V	0.500	120.000	36.800	PASS	90V +12V1 min
		+3.3V	0.500				
		-12V	0.100				
		+5Vsb	0.100				
		+12V	0.500				
264.000	63.000	+5V	1.730	120.000	33.600	PASS	264V +12V1 max
		+3.3V	0.500				
		-12V	0.100				
		+5Vsb	0.100				
		+12V	24.000				
90.000	47.000	+5V	0.500	120.000	11.600	PASS	90V -12V min
		+3.3V	0.500				
		-12V	0.100				
		+5Vsb	0.100				
		+12V	0.500				
90.000	47.000	+5V	18.000	120.000	20.800	PASS	90V -12V max
		+3.3V	0.500				
		-12V	0.300				
		+5Vsb	2.500				
		+12V	16.020				
264.000	63.000	+5V	0.500	120.000	12.000	PASS	264V -12V min
		+3.3V	0.500				
		-12V	0.100				
		+5Vsb	0.100				
		+12V	0.500				
264.000	63.000	+5V	18.000	120.000	20.800	PASS	264V -12V max
		+3.3V	0.500				
		-12V	0.300				
		+5Vsb	2.500				
		+12V	16.020				

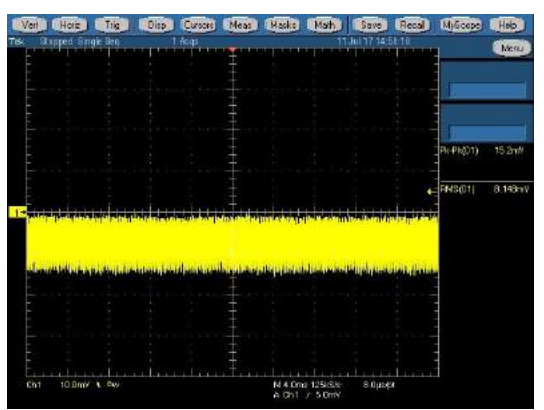
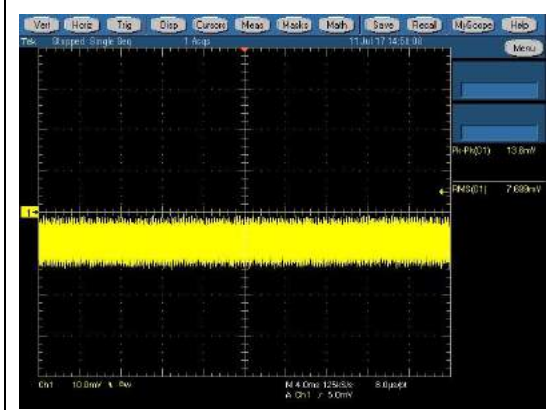
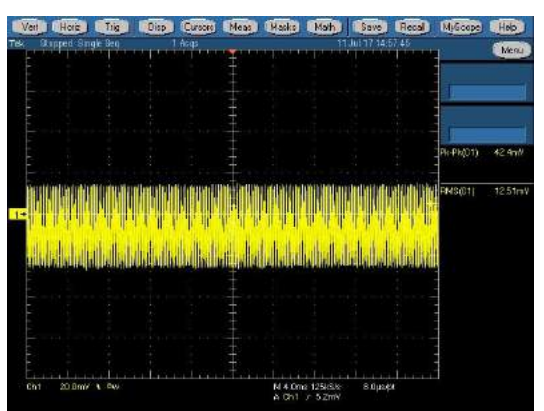
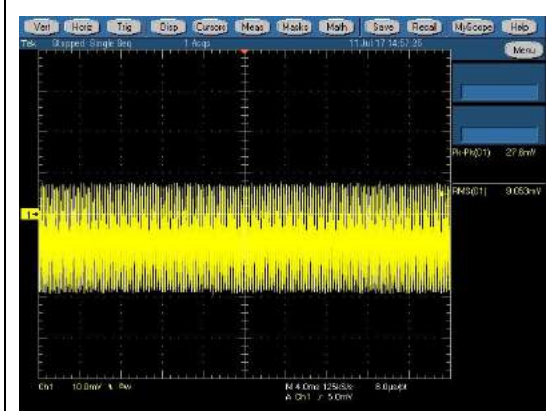
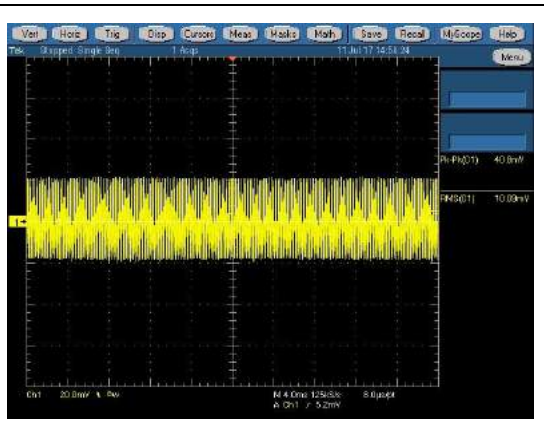
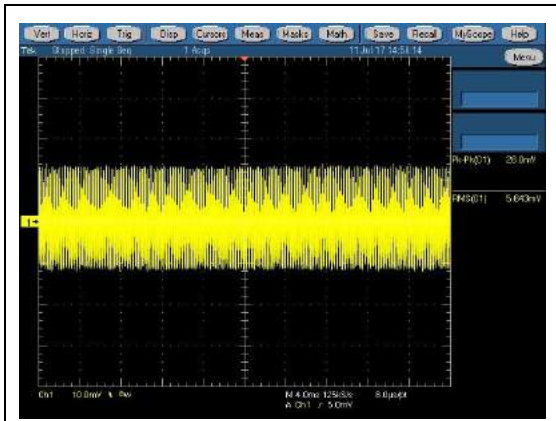

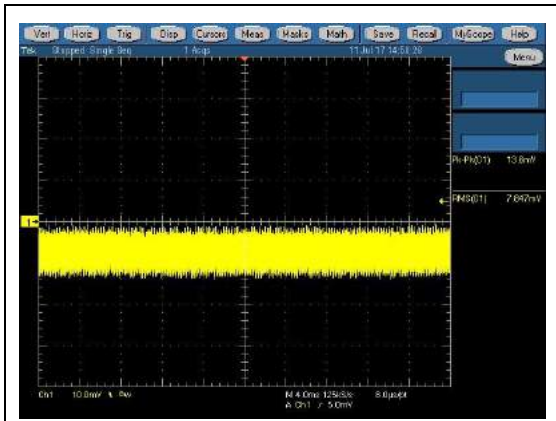

264V +3.3V min  
CH1:+3.3V

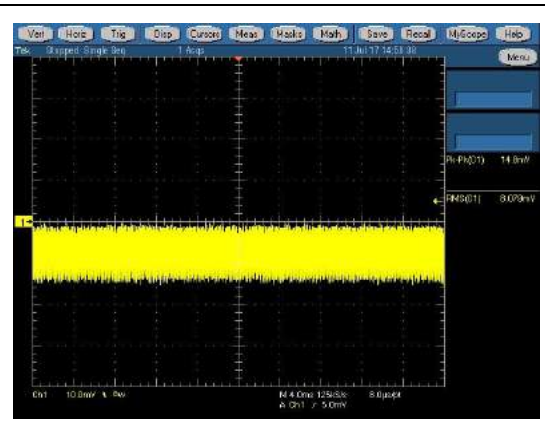

264V +3.3V max  
CH1:+3.3V

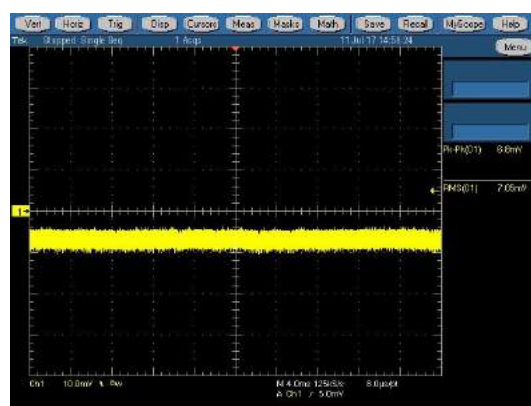

90V +5VSB min  
CH1:+5Vsb

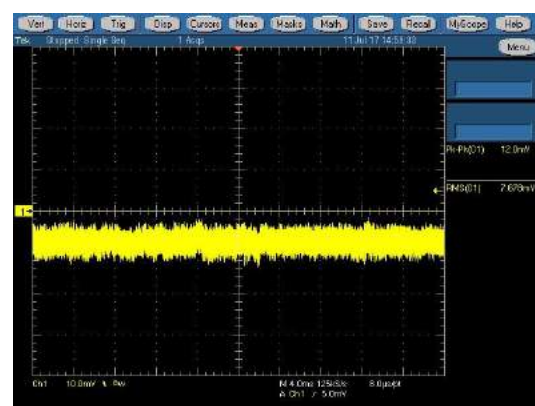

90V +5VSB max  
CH1:+5Vsb

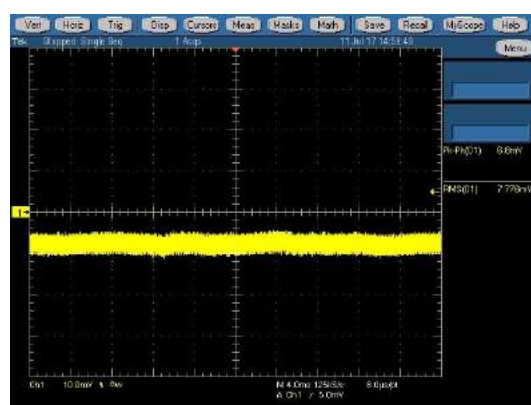

264V +5VSB min  
CH1:+5Vsb

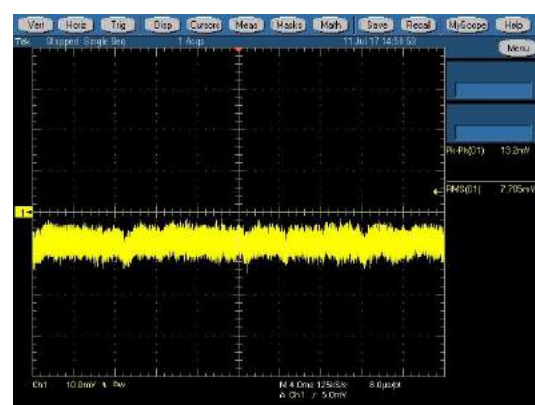

264V +5VSB max  
CH1:+5Vsb

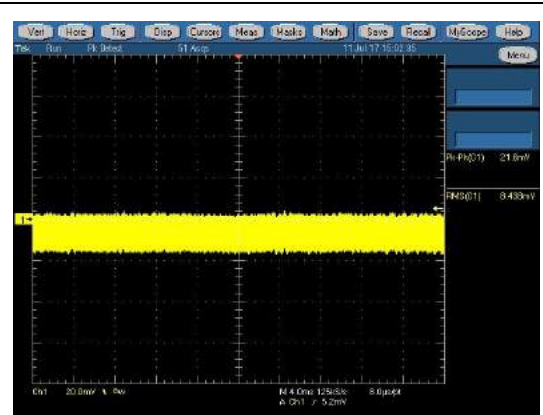
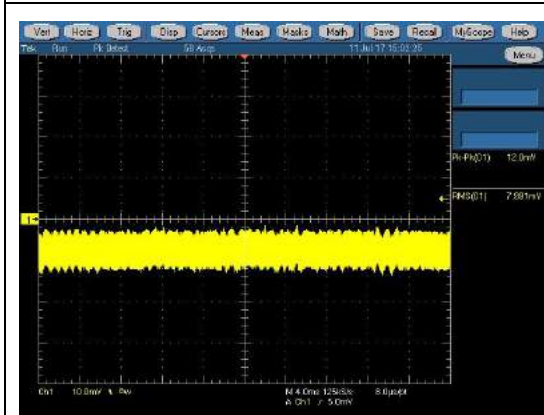
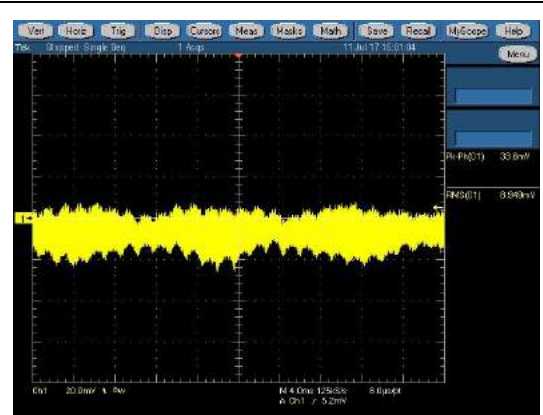
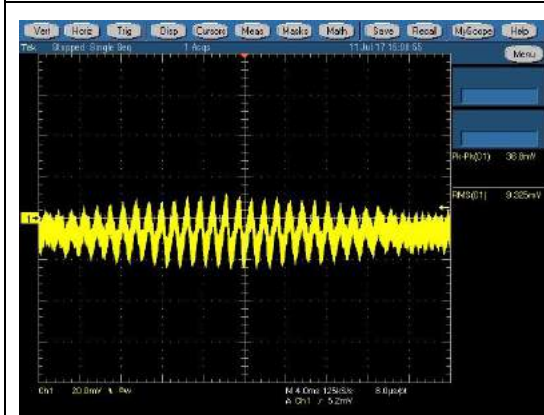
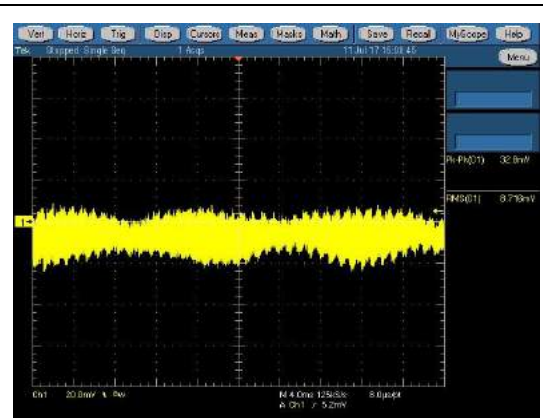
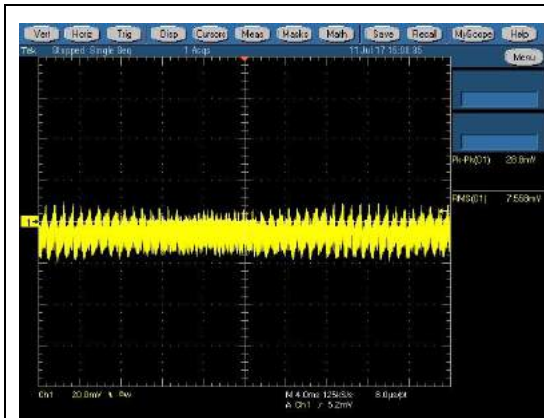

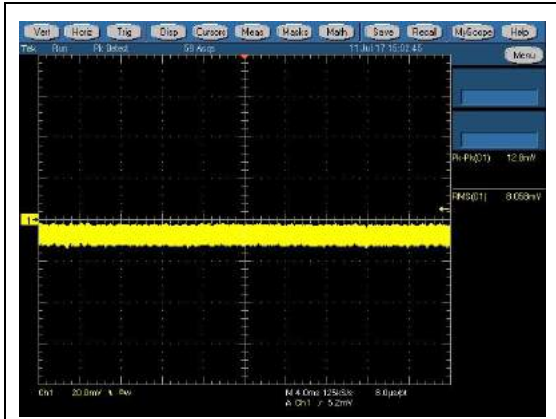

264V -12V min  
CH1:-12V

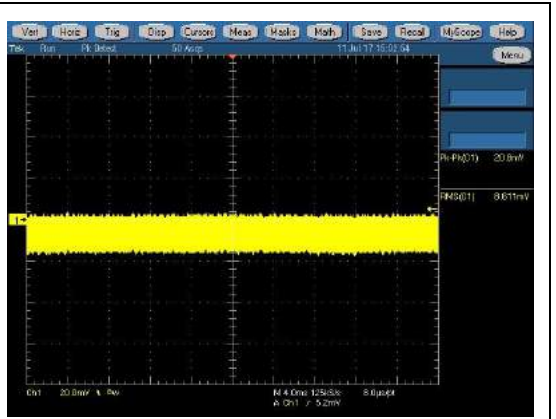

264V -12V max  
CH1:-12V

T a c o n _ d e l a y								
Input		Output		Test Limits		Test Results	Pass / Fail	Remarks
Volt	Freq	Volt	Load	Min	Max			
90.000	47.000	+5V	0.500	*	2500.000	638.300	PASS	90V +5V min
		+3.3V	0.500					
		-12V	0.100					
		+5Vsb	0.100					
		+12V	0.500					
90.000	47.000	+5V	18.000	*	2500.000	676.700	PASS	90V +5V max
		+3.3V	0.500					
		-12V	0.300					
		+5Vsb	2.500					
		+12V	16.020					
264.000	63.000	+5V	0.500	*	2500.000	392.300	PASS	264V +5V min
		+3.3V	0.500					
		-12V	0.100					
		+5Vsb	0.100					
		+12V	0.500					
264.000	63.000	+5V	18.000	*	2500.000	387.100	PASS	264V +5V max
		+3.3V	0.500					
		-12V	0.300					
		+5Vsb	2.500					
		+12V	16.020					
90.000	47.000	+5V	0.500	*	2500.000	637.500	PASS	90V +3.3V min
		+3.3V	0.500					
		-12V	0.100					
		+5Vsb	0.100					
		+12V	0.500					
90.000	47.000	+5V	8.480	*	2500.000	655.900	PASS	90V +3.3V max
		+3.3V	15.000					
		-12V	0.300					
		+5Vsb	2.500					
		+12V	16.020					
264.000	63.000	+5V	0.500	*	2500.000	389.100	PASS	264V +3.3V min
		+3.3V	0.500					
		-12V	0.100					
		+5Vsb	0.100					
		+12V	0.500					
264.000	63.000	+5V	8.480	*	2500.000	387.500	PASS	264V +3.3V max
		+3.3V	15.000					
		-12V	0.300					
		+5Vsb	2.500					
		+12V	16.020					
90.000	47.000	+5V	0.500	*	2500.000	618.300	PASS	90V +12V1 min
		+3.3V	0.500					
		-12V	0.100					
		+5Vsb	0.100					
		+12V	0.500					
90.000	47.000	+5V	1.730	*	2500.000	643.900	PASS	90V +12V1 max
		+3.3V	0.500					
		-12V	0.100					
		+5Vsb	0.100					
		+12V	24.000					

264.000	63.000	+5V	0.500	*	2500.000	364.300	PASS	264V +12V1 min
		+3.3V	0.500					
		-12V	0.100					
		+5Vsb	0.100					
		+12V	0.500					
264.000	63.000	+5V	1.730	*	2500.000	369.900	PASS	264V +12V1 max
		+3.3V	0.500					
		-12V	0.100					
		+5Vsb	0.100					
		+12V	24.000					
90.000	47.000	+5V	0.500	*	1500.000	63.820	PASS	90V +5VSB min
		+3.3V	0.500					
		-12V	0.100					
		+5Vsb	0.100					
		+12V	0.500					
90.000	47.000	+5V	18.000	*	1500.000	46.140	PASS	90V +5VSB max
		+3.3V	0.500					
		-12V	0.300					
		+5Vsb	2.500					
		+12V	16.020					
264.000	63.000	+5V	0.500	*	1500.000	25.180	PASS	264V +5VSB min
		+3.3V	0.500					
		-12V	0.100					
		+5Vsb	0.100					
		+12V	0.500					
264.000	63.000	+5V	18.000	*	1500.000	18.780	PASS	264V +5VSB max
		+3.3V	0.500					
		-12V	0.300					
		+5Vsb	2.500					
		+12V	16.020					

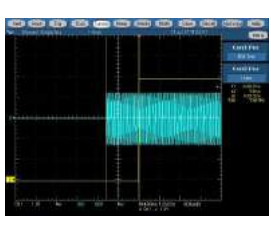
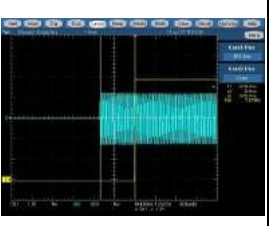
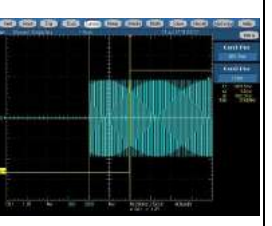
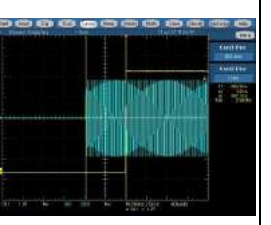
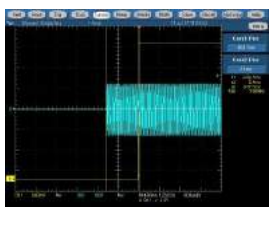
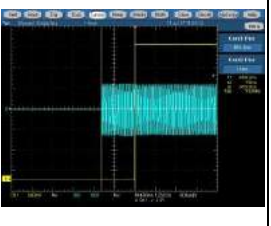
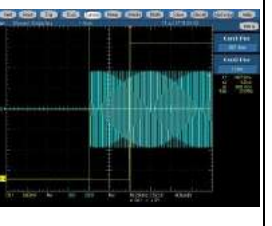
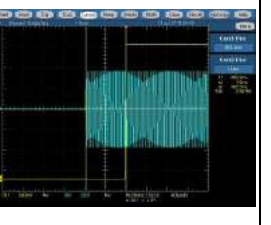
			
90V +5V min CH1: +5V, CH2: Vin	90V +5V max CH1: +5V, CH2: Vin	264V +5V min CH1: +5V, CH2: Vin	264V +5V max CH1: +5V, CH2: Vin
			
90V +3.3V min CH1: +3.3V, CH2: Vin	90V +3.3V max CH1: +3.3V, CH2: Vin	264V +3.3V min CH1: +3.3V, CH2: Vin	264V +3.3V max CH1: +3.3V, CH2: Vin

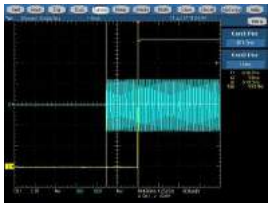
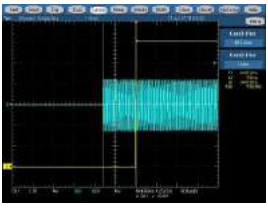
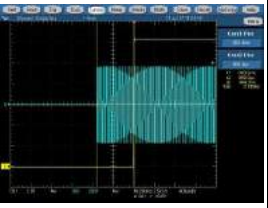
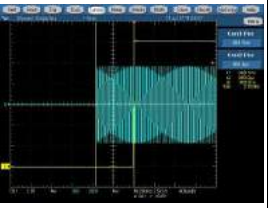
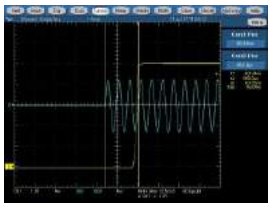
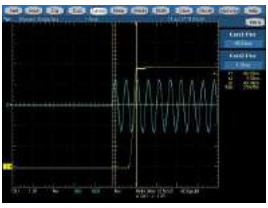
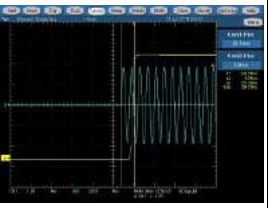
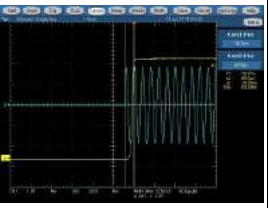
			
90V +12V1 min CH1: +12V1, CH2: Vin	90V +12V1 max CH1: +12V1, CH2: Vin	264V +12V1 min CH1: +12V1, CH2: Vin	264V +12V1 max CH1: +12V1, CH2: Vin
			
90V +5VSB min CH1: +5VSB, CH2: Vin	90V +5VSB max CH1: +5VSB, CH2: Vin	264V +5VSB min CH1: +5VSB, CH2: Vin	264V +5VSB max CH1: +5VSB, CH2: Vin

T vout holdup								
Input		Output		Test Limits		Test Results	Pass / Fail	Remarks
Volt	Freq	Volt	Load	Min	Max			
90.000	47.000	+5V	0.500	12.000	*	43.680	PASS	90V +5V min
		+3.3V	0.500					
		-12V	0.100					
		+5Vsb	0.100					
		+12V	0.500					
90.000	47.000	+5V	18.000	12.000	*	23.080	PASS	90V +15V max
		+3.3V	0.500					
		-12V	0.300					
		+5Vsb	2.500					
		+12V	16.020					
264.000	63.000	+5V	0.500	12.000	*	51.760	PASS	264V +5V min
		+3.3V	0.500					
		-12V	0.100					
		+5Vsb	0.100					
		+12V	0.500					
264.000	63.000	+5V	18.000	12.000	*	27.600	PASS	264V +5V max
		+3.3V	0.500					
		-12V	0.300					
		+5Vsb	2.500					
		+12V	16.020					
90.000	47.000	+5V	0.500	12.000	*	48.800	PASS	90V +3.3V min
		+3.3V	0.500					
		-12V	0.100					
		+5Vsb	0.100					
		+12V	0.500					
90.000	47.000	+5V	8.480	12.000	*	22.880	PASS	90V

		+3.3V	15.000					+3.3V max
		-12V	0.300					
		+5Vsb	2.500					
		+12V	16.020					
264.000	63.000	+5V	0.500	12.000	*	54.800	PASS	264V +3.3V min
		+3.3V	0.500					
		-12V	0.100					
		+5Vsb	0.100					
		+12V	0.500					
264.000	63.000	+5V	8.480	12.000	*	27.040	PASS	264V +3.3V max
		+3.3V	15.000					
		-12V	0.300					
		+5Vsb	2.500					
		+12V	16.020					
90.000	47.000	+5V	0.500	12.000	*	22.400	PASS	90V +12V1 min
		+3.3V	0.500					
		-12V	0.100					
		+5Vsb	0.100					
		+12V	0.500					
90.000	47.000	+5V	1.730	12.000	*	21.280	PASS	90V +12V1 max
		+3.3V	0.500					
		-12V	0.100					
		+5Vsb	0.100					
		+12V	24.000					
264.000	63.000	+5V	0.500	12.000	*	30.080	PASS	264V +12V1 min
		+3.3V	0.500					
		-12V	0.100					
		+5Vsb	0.100					
		+12V	0.500					
264.000	63.000	+5V	1.730	12.000	*	26.040	PASS	264V +12V1 max
		+3.3V	0.500					
		-12V	0.100					
		+5Vsb	0.100					
		+12V	24.000					
90.000	47.000	+5V	0.500	12.000	*	5374.800	PASS	90V +5VSB min
		+3.3V	0.500					
		-12V	0.100					
		+5Vsb	0.100					
		+12V	0.500					
90.000	47.000	+5V	18.000	12.000	*	946.000	PASS	90V +5VSB max
		+3.3V	0.500					
		-12V	0.300					
		+5Vsb	2.500					
		+12V	16.020					
264.000	63.000	+5V	0.500	12.000	*	5874.800	PASS	264V +5VSB min
		+3.3V	0.500					
		-12V	0.100					
		+5Vsb	0.100					
		+12V	0.500					
264.000	63.000	+5V	18.000	12.000	*	1027.600	PASS	264V +5VSB max
		+3.3V	0.500					
		-12V	0.300					
		+5Vsb	2.500					
		+12V	16.020					

90V +5V min CH1: +5V, CH2: Vin	90V +15V max CH1: +5V, CH2: Vin	264V +5V min CH1: +5V, CH2: Vin	264V +5V max CH1: +5V, CH2: Vin
90V +3.3V min CH1: +3.3V, CH2: Vin	90V +3.3V max CH1: +3.3V, CH2: Vin	264V +3.3V min CH1: +3.3V, CH2: Vin	264V +3.3V max CH1: +3.3V, CH2: Vin
90V +12V1 min CH1: +12V1, CH2: Vin	90V +12V1 max CH1: +12V1, CH2: Vin	264V +12V1 min CH1: +12V1, CH2: Vin	264V +12V1 max CH1: +12V1, CH2: Vin
90V +5VSB min CH1: +5VSB, CH2: Vin	90V +5VSB max CH1: +5VSB, CH2: Vin	264V +5VSB min CH1: +5VSB, CH2: Vin	264V +5VSB max CH1: +5VSB, CH2: Vin

Tvout_rise								
Input		Output		Test Limits		Test Results	Pass / Fail	Remarks
Volt	Freq	Volt	Load	Min	Max			
90.000	47.000	+5V	0.500	1.000	70.000	4.377	PASS	90V +5V min
		+3.3V	0.500					
		-12V	0.100					
		+5Vsb	0.100					
		+12V	0.500					

90.000	47.000	+5V	18.000	1.000	70.000	4.365	PASS	90V +5V max
		+3.3V	0.500					
		-12V	0.300					
		+5Vsb	2.500					
		+12V	16.020					
264.000	63.000	+5V	0.500	1.000	70.000	4.404	PASS	264V +5V min
		+3.3V	0.500					
		-12V	0.100					
		+5Vsb	0.100					
		+12V	0.500					
264.000	63.000	+5V	18.000	1.000	70.000	4.340	PASS	264V +5V max
		+3.3V	0.500					
		-12V	0.300					
		+5Vsb	2.500					
		+12V	16.020					
90.000	47.000	+5V	0.500	1.000	70.000	4.305	PASS	90V +3.3V min
		+3.3V	0.500					
		-12V	0.100					
		+5Vsb	0.100					
		+12V	0.500					
90.000	47.000	+5V	8.480	1.000	70.000	4.212	PASS	90V +3.3V max
		+3.3V	15.000					
		-12V	0.300					
		+5Vsb	2.500					
		+12V	16.020					
264.000	63.000	+5V	0.500	1.000	70.000	4.301	PASS	264V +3.3V min
		+3.3V	0.500					
		-12V	0.100					
		+5Vsb	0.100					
		+12V	0.500					
264.000	63.000	+5V	8.480	1.000	70.000	4.228	PASS	264V +3.3V max
		+3.3V	15.000					
		-12V	0.300					
		+5Vsb	2.500					
		+12V	16.020					
90.000	47.000	+5V	0.500	1.000	70.000	2.455	PASS	90V +12V1 min
		+3.3V	0.500					
		-12V	0.100					
		+5Vsb	0.100					
		+12V	0.500					
90.000	47.000	+5V	1.730	1.000	70.000	4.640	PASS	90V +12V1 max
		+3.3V	0.500					
		-12V	0.100					
		+5Vsb	0.100					
		+12V	24.000					
264.000	63.000	+5V	0.500	1.000	70.000	2.563	PASS	264V +12V1 min
		+3.3V	0.500					
		-12V	0.100					
		+5Vsb	0.100					
		+12V	0.500					
264.000	63.000	+5V	1.730	1.000	70.000	3.516	PASS	264V +12V1 max
		+3.3V	0.500					
		-12V	0.100					
		+5Vsb	0.100					
		+12V	24.000					



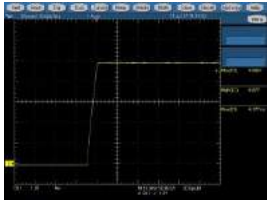
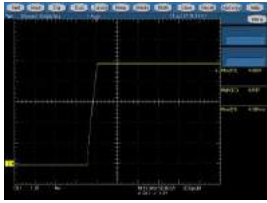
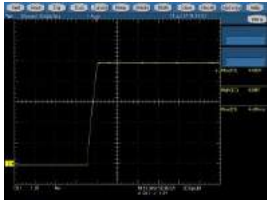
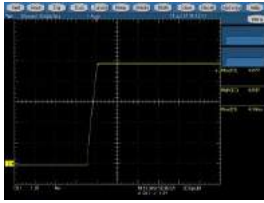
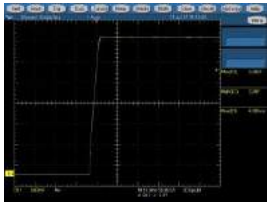
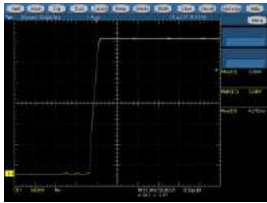
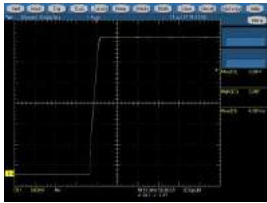
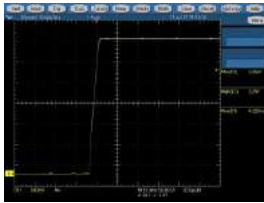
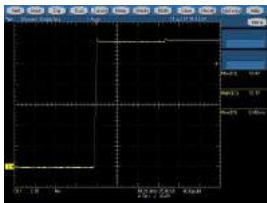
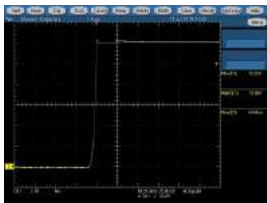
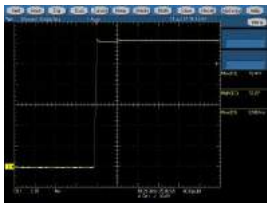
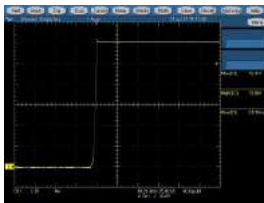

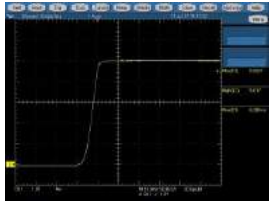
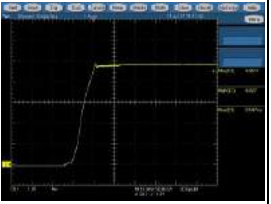
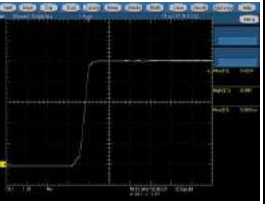
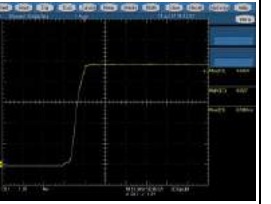

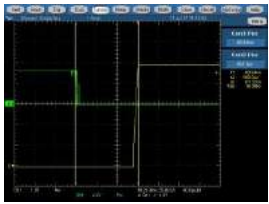
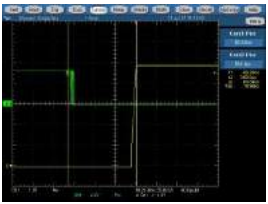
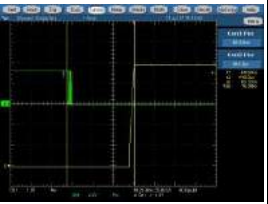
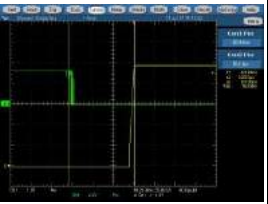

90.000	47.000	+5V	0.500	1.000	25.000	6.295	PASS	90V +5VSB min
		+3.3V	0.500					
		-12V	0.100					
		+5Vsb	0.100					
		+12V	0.500					
90.000	47.000	+5V	18.000	1.000	25.000	9.547	PASS	90V +5VSB max
		+3.3V	0.500					
		-12V	0.300					
		+5Vsb	2.500					
		+12V	16.020					
264.000	63.000	+5V	0.500	1.000	25.000	5.003	PASS	264V +5VSB min
		+3.3V	0.500					
		-12V	0.100					
		+5Vsb	0.100					
		+12V	0.500					
264.000	63.000	+5V	18.000	1.000	25.000	6.588	PASS	264V +5VSB max
		+3.3V	0.500					
		-12V	0.300					
		+5Vsb	2.500					
		+12V	16.020					

			
90V +5V min CH1: +5V	90V +5V max CH1: +5V	264V +5V min CH1: +5V	264V +5V max CH1: +5V
			
90V +3.3V min CH1: +3.3V	90V +3.3V max CH1: +3.3V	264V +3.3V min CH1: +3.3V	264V +3.3V max CH1: +3.3V
			
90V +12V1 min CH1: +12V1	90V +12V1 max CH1: +12V1	264V +12V1 min CH1: +12V1	264V +12V1 max CH1: +12V1

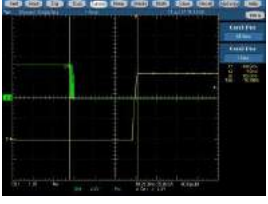
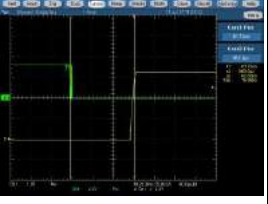
			
90V +5VSB min CH1: +5VSB	90V +5VSB max CH1: +5VSB	264V +5VSB min CH1: +5VSB	264V +5VSB max CH1: +5VSB

T <sub>pson on delay</sub>								
Input		Output		Test Limits		Test Results	Pass / Fail	Remarks
Volt	Freq	Volt	Load	Min	Max			
90.000	47.000	+5V	0.500	5.000	400.000	61.120	PASS	90V +5V min
		+3.3V	0.500					
		-12V	0.100					
		+5Vsb	0.100					
		+12V	0.500					
90.000	47.000	+5V	18.000	5.000	400.000	66.840	PASS	90V +5V max
		+3.3V	0.500					
		-12V	0.300					
		+5Vsb	2.500					
		+12V	16.020					
264.000	63.000	+5V	0.500	5.000	400.000	65.120	PASS	264V +5V min
		+3.3V	0.500					
		-12V	0.100					
		+5Vsb	0.100					
		+12V	0.500					
264.000	63.000	+5V	18.000	5.000	400.000	63.960	PASS	264V +5V max
		+3.3V	0.500					
		-12V	0.300					
		+5Vsb	2.500					
		+12V	16.020					
90.000	47.000	+5V	0.500	5.000	400.000	66.160	PASS	90V +3.3V min
		+3.3V	0.500					
		-12V	0.100					
		+5Vsb	0.100					
		+12V	0.500					
90.000	47.000	+5V	8.480	5.000	400.000	65.000	PASS	90V +3.3V max
		+3.3V	15.000					
		-12V	0.300					
		+5Vsb	2.500					
		+12V	16.020					
264.000	63.000	+5V	0.500	5.000	400.000	62.680	PASS	264V +3.3V min
		+3.3V	0.500					
		-12V	0.100					
		+5Vsb	0.100					
		+12V	0.500					
264.000	63.000	+5V	8.480	5.000	400.000	68.560	PASS	264V +3.3V max
		+3.3V	15.000					
		-12V	0.300					
		+5Vsb	2.500					





		+12V	16.020					
90.000	47.000	+5V	0.500	5.000	400.000	41.560	PASS	90V +12V1 min
		+3.3V	0.500					
		-12V	0.100					
		+5Vsb	0.100					
		+12V	0.500					
90.000	47.000	+5V	1.730	5.000	400.000	49.960	PASS	90V +12V1 max
		+3.3V	0.500					
		-12V	0.100					
		+5Vsb	0.100					
		+12V	24.000					
264.000	63.000	+5V	0.500	5.000	400.000	46.480	PASS	264V +12V1 min
		+3.3V	0.500					
		-12V	0.100					
		+5Vsb	0.100					
		+12V	0.500					
264.000	63.000	+5V	1.730	5.000	400.000	46.720	PASS	264V +12V1 max
		+3.3V	0.500					
		-12V	0.100					
		+5Vsb	0.100					
		+12V	24.000					

			
90V +5V min CH1: +5V; CH4: PS_ON	90V +5V max CH1: +5V; CH4: PS_ON	264V +5V min CH1: +5V; CH4: PS_ON	264V +5V max CH1: +5V; CH4: PS_ON
			
90V +3.3V min CH1: +3.3V; CH4: PS_ON	90V +3.3V max CH1: +3.3V; CH4: PS_ON	264V +3.3V min CH1: +3.3V; CH4: PS_ON	264V +3.3V max CH1: +3.3V; CH4: PS_ON
			
90V +12V1 min	90V +12V1 max	264V +12V1 min	264V +12V1 max

CH1: +12V1; CH4: PS_ON	CH1: +12V1; CH4: PS_ON	CH1: +12V1; CH4: PS_ON	CH1: +12V1; CH4: PS_ON
---------------------------	---------------------------	---------------------------	---------------------------

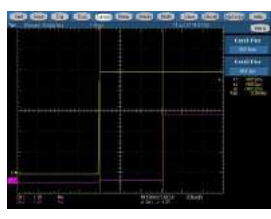
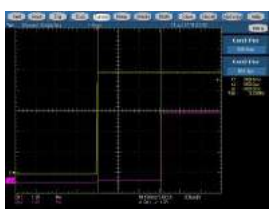
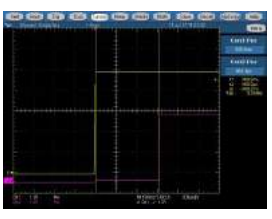
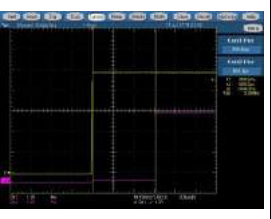
T pwok on acon								
Input		Output		Test Limits		Test Results	Pass / Fail	Remarks
Volt	Freq	Volt	Load	Min	Max			
90.000	47.000	+5V	0.500	100.000	500.000	307.200	PASS	90V +5V min
		+3.3V	0.500					
		-12V	0.100					
		+5Vsb	0.100					
		+12V	0.500					
90.000	47.000	+5V	18.000	100.000	500.000	308.800	PASS	90V +5V max
		+3.3V	0.500					
		-12V	0.300					
		+5Vsb	2.500					
		+12V	16.020					
264.000	63.000	+5V	0.500	100.000	500.000	309.200	PASS	264V +5V min
		+3.3V	0.500					
		-12V	0.100					
		+5Vsb	0.100					
		+12V	0.500					
264.000	63.000	+5V	18.000	100.000	500.000	304.000	PASS	264V +5V max
		+3.3V	0.500					
		-12V	0.300					
		+5Vsb	2.500					
		+12V	16.020					
90.000	47.000	+5V	0.500	100.000	500.000	309.000	PASS	90V +3.3V min
		+3.3V	0.500					
		-12V	0.100					
		+5Vsb	0.100					
		+12V	0.500					
90.000	47.000	+5V	8.480	100.000	500.000	310.800	PASS	90V +3.3V max
		+3.3V	15.000					
		-12V	0.300					
		+5Vsb	2.500					
		+12V	16.020					
264.000	63.000	+5V	0.500	100.000	500.000	308.000	PASS	264V +3.3V min
		+3.3V	0.500					
		-12V	0.100					
		+5Vsb	0.100					
		+12V	0.500					
264.000	63.000	+5V	8.480	100.000	500.000	308.800	PASS	264V +3.3V max
		+3.3V	15.000					
		-12V	0.300					
		+5Vsb	2.500					
		+12V	16.020					
90.000	47.000	+5V	0.500	100.000	500.000	329.000	PASS	90V +12V1 min
		+3.3V	0.500					
		-12V	0.100					
		+5Vsb	0.100					
		+12V	0.500					
90.000	47.000	+5V	1.730	100.000	500.000	325.600	PASS	90V

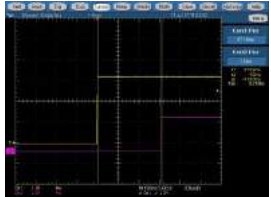
		+3.3V	0.500					+12V1 max
		-12V	0.100					
		+5Vsb	0.100					
		+12V	24.000					
264.000	63.000	+5V	0.500	100.000	500.000	327.400	PASS	264V +12V1 min
		+3.3V	0.500					
		-12V	0.100					
		+5Vsb	0.100					
		+12V	0.500					
264.000	63.000	+5V	1.730	100.000	500.000	329.800	PASS	264V +12V1 max
		+3.3V	0.500					
		-12V	0.100					
		+5Vsb	0.100					
		+12V	24.000					

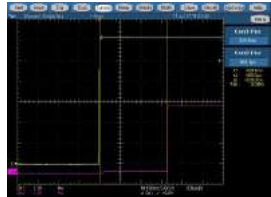
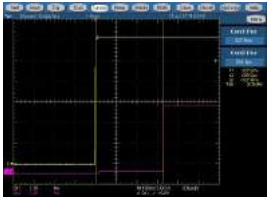
			
90V +5V min CH1: +5V; CH3: PG	90V +5V max CH1: +5V; CH3: PG	264V +5V min CH1: +5V; CH3: PG	264V +5V max CH1: +5V; CH3: PG
			
90V +3.3V min CH1: +3.3V; CH3: PG	90V +3.3V max CH1: +3.3V; CH3: PG	264V +3.3V min CH1: +3.3V; CH3: PG	264V +3.3V max CH1: +3.3V; CH3: PG
			
90V +12V1 min CH1: +12V1; CH3: PG	90V +12V1 max CH1: +12V1; CH3: PG	264V +12V1 min CH1: +12V1; CH3: PG	264V +12V1 max CH1: +12V1; CH3: PG

90V +5V min CH1: +5V; CH3: PG	90V +5V max CH1: +5V; CH3: PG	264V +5V min CH1: +5V; CH3: PG	264V +5V max CH1: +5V; CH3: PG
90V +3.3V min CH1: +3.3V; CH3: PG	90V +3.3V max CH1: +3.3V; CH3: PG	264V +3.3V min CH1: +3.3V; CH3: PG	264V +3.3V max CH1: +3.3V; CH3: PG
90V +12V1 min CH1: +12V1; CH3: PG	90V +12V1 max CH1: +12V1; CH3: PG	264V +12V1 min CH1: +12V1; CH3: PG	264V +12V1 max CH1: +12V1; CH3: PG

Tpwok_holdup								
Input		Output		Test Limits		Test Results	Pass / Fail	Remarks
Volt	Freq	Volt	Load	Min	Max			
90.000	47.000	+5V	0.500	10.000	*	20.640	PASS	90V PG min
		+3.3V	0.500					
		-12V	0.100					
		+5Vsb	0.100					
		+12V	0.500					
90.000	47.000	+5V	18.000	10.000	*	21.640	PASS	90V PG max
		+3.3V	0.500					
		-12V	0.300					
		+5Vsb	2.500					
		+12V	16.020					
264.000	63.000	+5V	0.500	10.000	*	27.680	PASS	264V PG min
		+3.3V	0.500					
		-12V	0.100					
		+5Vsb	0.100					
		+12V	0.500					
264.000	63.000	+5V	18.000	10.000	*	24.200	PASS	264V PG

		+3.3V	0.500					max
		-12V	0.300					
		+5Vsb	2.500					
		+12V	16.020					

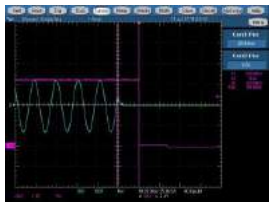
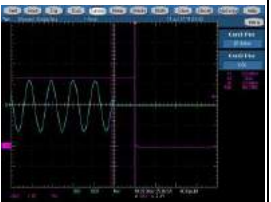
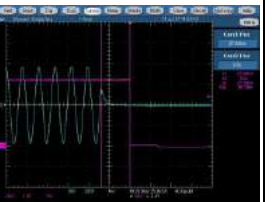
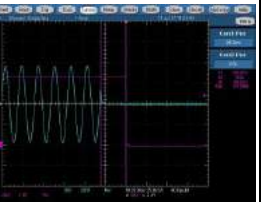

			
90V PG min CH2:Vin; CH3: PG	90V PG max CH2:Vin; CH3: PG	264V PG min CH2:Vin; CH3: PG	264V PG max CH2:Vin; CH3: PG

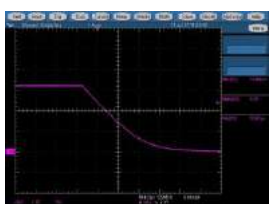
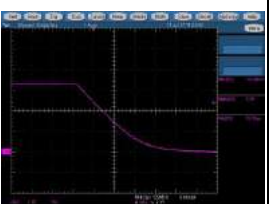
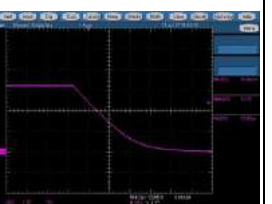
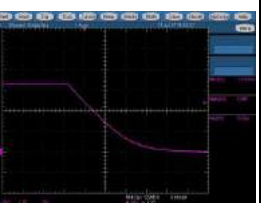
T pwok_fall								
Input		Output		Test Limits		Test Results	Pass / Fail	Remarks
Volt	Freq	Volt	Load	Min	Max			
90.000	47.000	+5V	0.500	*	0.100	0.013	PASS	90V PG min
		+3.3V	0.500					
		-12V	0.100					
		+5Vsb	0.100					
		+12V	0.500					
90.000	47.000	+5V	18.000	*	0.100	0.013	PASS	90V PG max
		+3.3V	0.500					
		-12V	0.300					
		+5Vsb	2.500					
		+12V	16.020					
264.000	63.000	+5V	0.500	*	0.100	0.013	PASS	264V PG min
		+3.3V	0.500					
		-12V	0.100					
		+5Vsb	0.100					
		+12V	0.500					
264.000	63.000	+5V	18.000	*	0.100	0.013	PASS	264V PG max
		+3.3V	0.500					
		-12V	0.300					
		+5Vsb	2.500					
		+12V	16.020					

			
90V PG min CH3: PG	90V PG max CH3: PG	264V PG min CH3: PG	264V PG max CH3: PG

T pson_pwok
-------------



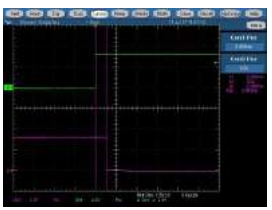
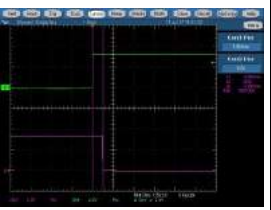

Input		Output		Test Limits		Test Results	Pass / Fail	Remarks
Volt	Freq	Volt	Load	Min	Max			
90.000	47.000	+5V	0.500	*	50.000	2.216	PASS	90V PG min
		+3.3V	0.500					
		-12V	0.100					
		+5Vsb	0.100					
		+12V	0.500					
90.000	47.000	+5V	18.000	*	50.000	2.064	PASS	90V PG max
		+3.3V	0.500					
		-12V	0.300					
		+5Vsb	2.500					
		+12V	16.020					
264.000	63.000	+5V	0.500	*	50.000	2.088	PASS	264V PG min
		+3.3V	0.500					
		-12V	0.100					
		+5Vsb	0.100					
		+12V	0.500					
264.000	63.000	+5V	18.000	*	50.000	1.992	PASS	264V PG max
		+3.3V	0.500					
		-12V	0.300					
		+5Vsb	2.500					
		+12V	16.020					

			
90V PG min CH3: PG; CH4: PS_ON	90V PG max CH3: PG; CH4: PS_ON	264V PG min CH3: PG; CH4: PS_ON	264V PG max CH3: PG; CH4: PS_ON

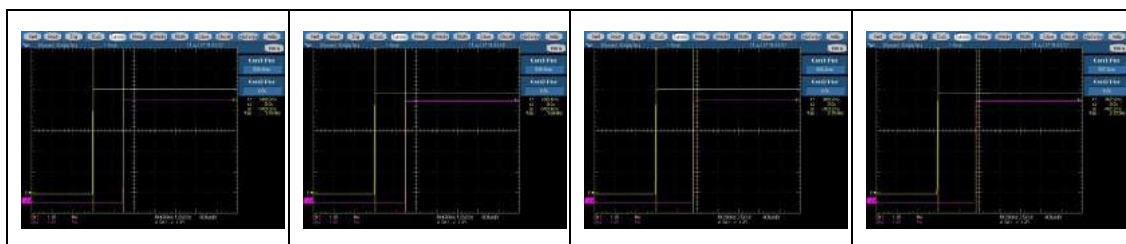
Tsb_vout								
Input		Output		Test Limits		Test Results	Pass / Fail	Remarks
Volt	Freq	Volt	Load	Min	Max			
90.000	47.000	+5V	0.500	50.000	1000.000	588.000	PASS	90V +5V min
		+3.3V	0.500					
		-12V	0.100					
		+5Vsb	0.100					
		+12V	0.500					
90.000	47.000	+5V	18.000	50.000	1000.000	590.400	PASS	90V +5V max
		+3.3V	0.500					
		-12V	0.300					
		+5Vsb	2.500					
		+12V	16.020					
264.000	63.000	+5V	0.500	50.000	1000.000	363.200	PASS	264V +5V min
		+3.3V	0.500					
		-12V	0.100					

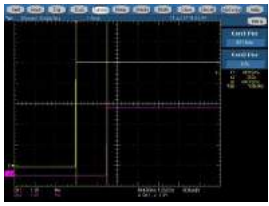
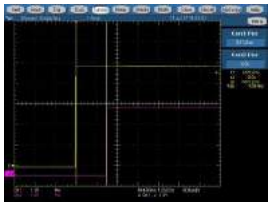
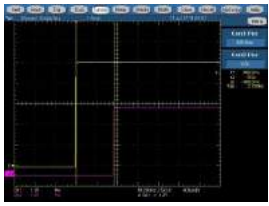
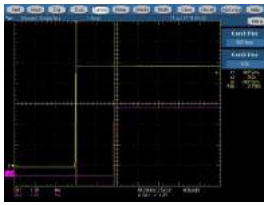
		+5Vsb	0.100					
		+12V	0.500					
264.000	63.000	+5V	18.000	50.000	1000.000	367.200	PASS	264V +5V max
		+3.3V	0.500					
		-12V	0.300					
		+5Vsb	2.500					
		+12V	16.020					
90.000	47.000	+5V	0.500	50.000	1000.000	601.600	PASS	90V +3.3V min
		+3.3V	0.500					
		-12V	0.100					
		+5Vsb	0.100					
		+12V	0.500					
90.000	47.000	+5V	8.480	50.000	1000.000	591.200	PASS	90V +3.3V max
		+3.3V	15.000					
		-12V	0.300					
		+5Vsb	2.500					
		+12V	16.020					
264.000	63.000	+5V	0.500	50.000	1000.000	366.800	PASS	264V +3.3V min
		+3.3V	0.500					
		-12V	0.100					
		+5Vsb	0.100					
		+12V	0.500					
264.000	63.000	+5V	8.480	50.000	1000.000	367.600	PASS	264V +3.3V max
		+3.3V	15.000					
		-12V	0.300					
		+5Vsb	2.500					
		+12V	16.020					
90.000	47.000	+5V	0.500	50.000	1000.000	580.800	PASS	90V +12V1 min
		+3.3V	0.500					
		-12V	0.100					
		+5Vsb	0.100					
		+12V	0.500					
90.000	47.000	+5V	1.730	50.000	1000.000	588.800	PASS	90V +12V1 max
		+3.3V	0.500					
		-12V	0.100					
		+5Vsb	0.100					
		+12V	24.000					
264.000	63.000	+5V	0.500	50.000	1000.000	348.000	PASS	264V +12V1 min
		+3.3V	0.500					
		-12V	0.100					
		+5Vsb	0.100					
		+12V	0.500					
264.000	63.000	+5V	1.730	50.000	1000.000	349.600	PASS	264V +12V1 max
		+3.3V	0.500					
		-12V	0.100					
		+5Vsb	0.100					
		+12V	24.000					

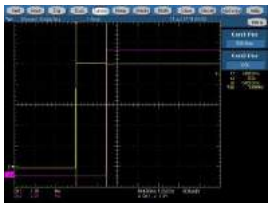

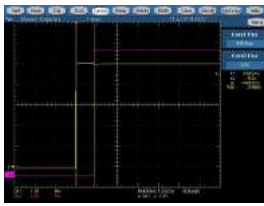
90V +5V min CH1:+5VSB; CH3:+5V	90V +5V max CH1:+5VSB; CH3:+5V	264V +5V min CH1:+5VSB; CH3:+5V	264V +5V max CH1:+5VSB; CH3:+5V
			
90V +3.3V min CH1:+5VSB; CH3:+3.3V	90V +3.3V max CH1:+5VSB; CH3:+3.3V	264V +3.3V min CH1:+5VSB; CH3:+3.3V	264V +3.3V max CH1:+5VSB; CH3:+3.3V
			
90V +12V1 min CH1:+5VSB; CH3:+12V1	90V +12V1 max CH1:+5VSB; CH3:+12V1	264V +12V1 min CH1:+5VSB; CH3:+12V1	264V +12V1 max CH1:+5VSB; CH3:+12V1