



SPECIFICATION

Model Name :

PIST2040-EPSH-80-N

PIST2050-EPSH-80-N

Description :

400W 、 500W Mini Redundant Power Supply (PSII)

Version : B0

Issued Date : 20201207



1. General Description

This specification defines the characteristic of 1 + 1 redundant power supply with 4 Unit high.
And **CRS** model name is PIST2040-EPSH-80-N for 400W 、PIST2050-EPSH-80-N for 500W output.

2. Input Characteristic

2.1. Input connector

The input connector shall be an IEC60320 C14 inlet, rated for 10A/250Vac.

2.2. Input Voltage and Frequency

<i>Minimum</i>	<i>Nominal</i>	<i>Maximum</i>	<i>Measure</i>
90	100~240	264	Vac
47	50~60	63	Hz

2.3. Input Current and Inrush Current

<i>Input Voltage</i>	<i>MAX. Input Current</i>	<i>Inrush Current</i>
115Vac	8A	25A
230Vac	4A	50A

2.4. Power Factor

The minimum power factor shall be 0.95 with full load and input 230Vac/50Hz.

3. Output Characteristic

3.1. DC Output Characteristic

<i>Output Voltage</i>	<i>Min. Current</i>	<i>Max. Current</i>	<i>Regulation</i>	<i>Ripple & Noise</i>
+3.3V	1A	25A	±5%	50mV
+5V	1A	25A	±5%	50mV
+12V	1A	33A/41A	±5%	120mV
-12V	0A	0.8A	±5%	120mV
+5VSB	0.1A	3.5A	±5%	50mV

Note :

1. The combined power from +3.3V and +5V shall not exceed 170W.
2. The max total power shall not exceed 400W/500W.
3. Ripple and noise bandwidth is set to 20MHz.
4. Add a 0.1uF ceramic capacitor in parallel with a 10uF tantalum capacitor at output connector terminals for ripple and noise measurement.



3.2. Efficiency

The minimum efficiency of power supply is 80% with full load and 115Vac/60Hz input.

3.3. Hold up Time

The output voltages stay in regulation at least 16ms with 100% load after loss of AC input.

3.4. Rise Time

The output voltages rise from 10% to 90% with full load shall be in 20ms maximum.

3.5. Dynamic Loading

The output voltages shall remain in regulation for the step loading, and in the limits for the capacitive loading specified below :

<i>Output</i>	<i>Step Load Size</i>	<i>Load Slew Rate</i>	<i>Capacitive Load</i>
+3.3V	30% of max load	0.5A / μ sec	1000uF
+5V	30% of max load	0.5A / μ sec	1000uF
+12V	65% of max load	0.5A / μ sec	2200uF
+5VSB	25% of max load	0.5A / μ sec	1uF

3.6. PSON Remote on/off Control

The PSON signal is required to remotely turn on/off the power supply.

PSON is an active low TTL compatible signal that turns on the main power rails.

	<i>PSU On</i>	<i>PSU Off</i>
PSON Signal	LOW (0.8V max.)	HI (2V min.)

3.7. Power Good Signal

Power Good, also called PG or PWOK, is an active high TTL compatible signal.

PG signal is to indicate that all output voltages are in regulation and ready for use.

Below is for a representation of the timing characteristics of PG signal.

Power Good on delay time	100ms to 500ms
Power Good off delay time	1ms (min.)



4. Protection

4.1. Over Current Protection

<i>Output</i>	<i>Min.</i>	<i>Max.</i>	<i>Comment</i>
+3.3V	110%	150%	PSU shutdown
+5V	110%	150%	PSU shutdown
+12V	110%	150%	PSU shutdown

4.2. Over Voltage Protection

<i>Output</i>	<i>Min.</i>	<i>Max.</i>	<i>Comment</i>
+3.3V	3.7V	4.1V	PSU shutdown
+5V	5.7V	6.5V	PSU shutdown
+12V	13.1V	14.5V	PSU shutdown

4.3. Short Circuit Protection

<i>Output</i>	<i>Comment</i>
+3.3V	PSU shutdown
+5V	PSU shutdown
+12V	PSU shutdown

4.4. Over Temperature Protection

The power supply would be protected against over temperature condition by loss of cooling or excessive ambient temperature. The PSU will shutdown in an OTP condition.



5. Power System Signal Status

5.1. Buzzer Status

<i>Power Supply Condition</i>	<i>Buzzer Status</i>
No input power to PSU	OFF
Input present/ only standby output on	OFF
Power supply outputs ON and OK	OFF
Power supply failure	Beeping

5.2. LED Indicator

<i>Power Supply Condition</i>	<i>Module LED</i>	<i>System LED</i>	<i>PW1/PW2 LED</i>
No input power to PSU	OFF	OFF	OFF
Input present/ only standby output on	Red	Amber	OFF
Power supply outputs ON and OK	Green	Green	Amber
Power supply failure	Red or OFF	Green Blinking	OFF

System LED and PW1 PW2 LED are optional.

5.3. TTL Signal

<i>Power Supply Condition</i>	<i>Output Condition</i>	
	<i>Min.</i>	<i>Max.</i>
Normal (Power Supply ON)	3V	5.25V
Failure (Power Supply OFF)	0V	1V

6. Insulation

6.1. Dielectric Withstand Voltage

Primary to Ground	1500Vac (10mA) for 1 second
-------------------	-----------------------------

6.2. Leakage Current

Leakage current is 3.5mA maximum at 240Vac/50Hz.

7. Safety

CB、CE、TUV、UL、BSMI、CCC。

Please visit our website and get the latest safety certificate.

8. EMC

CE、FCC、BSMI、CCC。(Class B)

Please visit our website and get the latest EMC certificate.



9. Environmental Requirement

9.1. Temperature

Operating : 0°C to +50°C.

Non Operating : -20°C to +70°C.

9.2. Humidity

Operating : 20% to 90% , non-condensing.

Non Operating : 5% to 95% , non-condensing.

9.3. Altitude

Operating : Up to 5000m.

9.4. Cooling Method

By DC fan.

10. Reliability

10.1. MTBF

Using MIL - HDBK -217F the calculated MTBF > 100,000 hours at 25°C.



11. Mechanical Drawing and Output Wire

11.1. Outline (bracket optional) : W150 * H86 * D174mm.

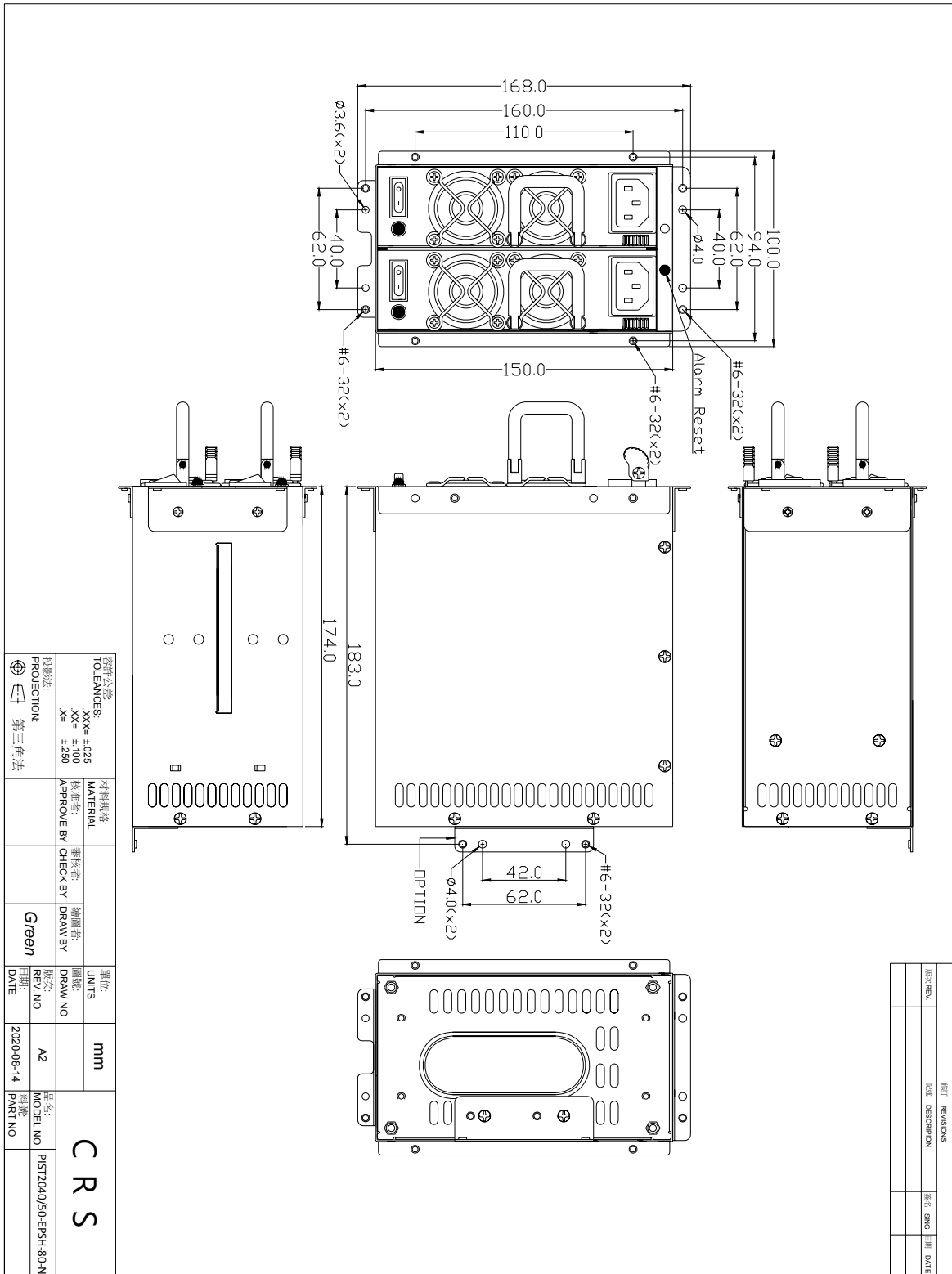



Brackets dimension:

修訂 REVISIONS			
版次 REV.	記述 DESCRIPTION	簽名 SING	日期 DATE

CR807A

PIST-4U

TOLERANCES: .XXX= ± .025 .XX= ± .100 .X= ± .250	MATERIAL				UNITS	mm	
	APPROVE BY	CHECK BY	DRAW BY	Green	DRAW NO	A1	CRS
PROJECTION: 					REV. NO	MODEL NO	BRACKET
					DATE	Mar.20.2015	PART NO

修訂 REVISIONS				
版次 REV.	記號 DESCRIPTION	簽名 SING	日期 DATE	

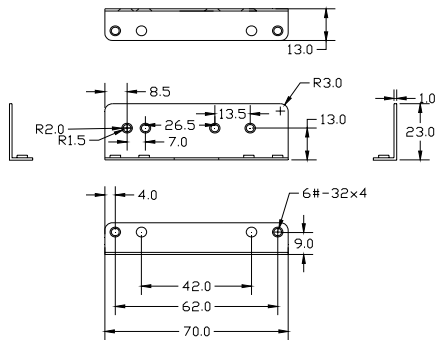

CR807-2

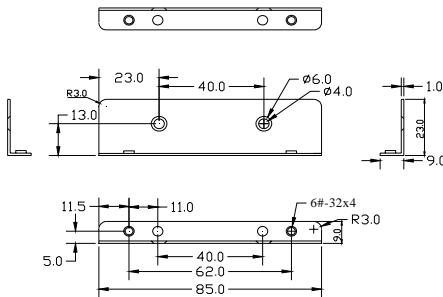

CR807-1A

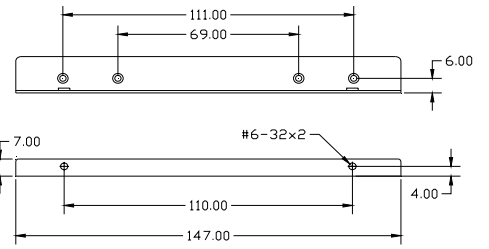

CR-808-1

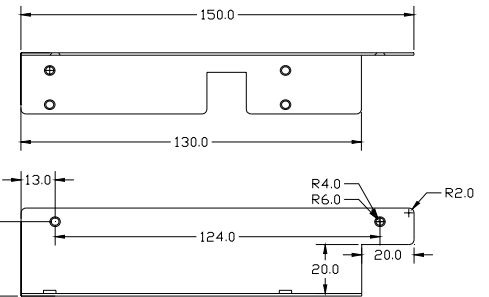

PIST-4UL

TOLERANCES: .XXX= ± .025 .XX= ± .100 .X= ± .250	MATERIAL			UNITS	mm		
	APPROVE BY	CHECK BY	DRAW BY	DRAW NO	A1	MODEL NO	
PROJECTION: 	Green			REV. NO	Mar.20.2015	PART NO	
				DATE			



12. Customization Note

Customization note shall be listed here.

End of File

NOTE : This data is subject to change without notice.