

Compuware Technology Inc.**Power Supply Specification****Model: CPR-1621-1M21****Revision Histories:**

Rev.	Description	Issued Date	Released by
1.0	Revise Format	Dec. 30, 2011	Evelyn Chen
1.1			
1.2			
1.3			
1.4			
1.5			
1.6			
1.7			
1.8			
1.9			

*Specification is subject to change without notice***Approved by:****Checked by:****Prepared by:**

1 Purpose

This specification defines the performance characteristics of a single-phase (3-wire), 1620W single output power supply with wide range input AC capability (90-264VAC/47-63Hz). The power supply shall be designed for parallel operation. In the event of a power supply failure, the redundant power supply continues to power the system even under over voltage fault. The power supply shall be designed for “hot swap” exchange and shall communicate to external devices through Inter-Integrated (I2C) Circuit protocol. The power supply will have an EEPROM for storing powers supply FRU information, and meet PMBus Revision 1.2 requirement.

2 AC Input Requirements

The power supply shall incorporate universal power input with active power factor correction, which shall reduce line harmonics in accordance with the EN61000-3-2.

2.1 AC Inlet Connector

The AC input connector shall be an IEC 320 C-14 power inlet. This inlet is rated for 15A / 250 VAC.

2.2 AC Input Voltage Specification

The power supply must operate within all specified limits over the following input voltage range. Harmonic distortion of up to 10% THD must not cause the power supply to go out of the specified limits. The power supply shall operate properly at 85 VAC input voltage to guarantee proper design margins.

AC Input Rating

PARAMETER	MIN	RATED	MAX
Voltage (110)	90 Vrms	100 – 127 Vrms	140 Vrms
Voltage (220)	180 Vrms	200 – 240 Vrms	264 Vrms
Frequency	47 Hz	50 / 60 Hz	63 Hz

2.3 Input Under Voltage

The power supply shall contain protection circuitry such that application of an input voltage below the minimum specified in section 2.2 shall not cause damage to the power supply.

2.4 Efficiency

This power supply shall meet 80PLUS Platinum efficiency requirement, the efficiency and power factor should meet or exceed the below requirement.

Efficiency, Power Factor and THD requirement

Load (%)	115Vac			230Vac		
	Max. THD (%)	Min. Power Factor	Min. Efficiency (%)	Max. THD (%)	Min. Power Factor	Min. Efficiency (%)
20	---	---	---	10	0.90	90.0
50	---	---	---	5	0.96	94.0
100	---	---	---	5	0.98	91.0

2.5 AC Line Fuse

The power supply shall incorporate one input fuse on the LINE side for input over current protection to prevent damage to the power supply and meet product safety requirements. Fuses should be slow blow type or equivalent to prevent nuisance trips. AC inrush current shall not cause the AC line fuse to blow under any conditions. All protection circuits in the power supply shall not cause the AC fuse to blow unless a component in the power supply has failed. This includes DC output load short conditions.

2.6 AC Inrush

The power supply must meet inrush requirements 2.2 for any rated AC voltage, during turn on at any phase of AC voltage, during a single cycle AC dropout condition, during repetitive ON/OFF cycling of AC, and when input power is applied to the power supply any initial current surge or spike of 10ms or less will not exceed **25A** peak.

2.7 AC Line Transient Specification

AC line transient conditions shall be defined as “sag” and “surge” conditions. Sag conditions (also referred to as “brownout” conditions) will be defined as the AC line voltage dropping below nominal voltage.

The power supply shall meet the requirements under the following AC line sag and surge conditions.

AC Line Sag Transient Performance

Duration	Sag	Operating AC Voltage	Line Frequency	Performance Criteria
Continuous	10%	Nominal AC Voltage ranges	50/60 Hz	No loss of function or performance
0 to 1 AC cycle	100%	Nominal AC Voltage ranges	50/60 Hz	Loss of function acceptable, self-recoverable
> 1 AC cycle	>10%	Nominal AC Voltage ranges	50/60 Hz	Loss of function acceptable, self-recoverable

AC Line Surge Transient Performance

Duration	Surge	Operating AC Voltage	Line Frequency	Performance Criteria
Continuous	10%	Nominal AC Voltages	50/60 Hz	No loss of function or performance
0 to 1AC cycle	30%	Mid-point of nominal AC Voltages	50/60 Hz	No loss of function or performance

2.8 AC Line Fast Transient Specification

The power supply shall meet the EN61000-4-5 directive and any additional requirements in IEC1000-45:1995 and the Level 3 requirements for surge-withstand capability, with the following conditions and exceptions:

- These input transients must not cause any out-of-regulation conditions, such as overshoot and undershoot, nor must it cause any nuisance trips of any of the power supply protection circuits.
- The surge-withstand test must not produce damage to the power supply.
- The supply must meet surge-withstand test conditions under maximum and minimum output load conditions.

3 DC Output Specification

3.1 Output regulation Requirements

All outputs must maintain their regulation with the below limits when measured at the output connector point or across the remote sense (if applicable) in any load condition defined in section 3.2

Voltage Regulation Limits

Output	Minimum	Nominal	Maximum	Unit
+12V	11.40	12.0	12.60	Vdc
+5Vsb	4.75	5.0	5.25	Vdc

There should never be any negative voltage for all outputs and signals during all occasion, including power on and off. During standby (PSON=off), all outputs, except +5VSB, should be below 50mV.

3.2 Output Current Requirements

All outputs must maintain their regulation as section 3.1 when loaded to the following loading

combination:

Loading Limits

Output	Minimum	Maximum	Unit	Input VAC
+12V	0.5	135	Adc	180 to 264
+12V	0.5	100	Adc	120 to 140
+12V	0.5	84	Adc	100 to 120
+5Vsb	0	4.0 (peak 6A)	Adc	90 to 264

The total output power can not exceed 1005W continuously for 100 to 120VAC input, 1205W continuously for 120 to 140VAC input and 1625W continuously for 180 to 264 VAC input. During load changes from minimum to maximum or maximum to minimum the unit must not shut down.

Note: +5Vsb will be designed to meet 6A load requirement and will be tested with 6A load at production line. However, model label (I/O label) will print 5Vsb max rating with 4A only.

3.3 Output Ripple and Noise

The following output ripple/noise requirements will be met throughout the load ranges specified in section 3.2 and under all input voltage conditions specified in section 2.1.

Ripple and noise are defined as periodic or random signals over the frequency band of 10Hz to 20MHz. Measurements will be made with an oscilloscope set to 20MHz bandwidth limit.

Measurement is done by using 10uF Tantalum in parallel with a 0.1uf ceramic capacitor, measured directly at the output connector side (Note: care must be taken when doing measurements such as using the smallest grounding wire.).

Ripple and Noise

Output	Maximum	Unit
+12V	120	mV
+5Vsb	50	mV

3.4 Output Dynamic Loading

The output voltages shall remain within the limits specified in section 3.1 for the step loading and within the limits specified in section 3.5 for the capacitive loading. The load transient repetition rate shall be tested between 50 Hz and 5 kHz at duty cycles ranging from 10%-90%. The load transient repetition rate is only a test specification. The Δ step load may occur anywhere within the MIN load to the MAX load shown in section 3.2

Transient Load Requirements

Output	Δ Step Load Size	Load Slew Rate	Capacitive Load
+12V	65% of max load	0.5A/uS	2200uF
+5Vsb	25% of max load	0.5A/uS	1uF

3.5 Capacitive Loading

The power supply shall be stable and meet all requirements, except dynamic loading requirements, with the following capacitive loading ranges.

Capacitive Loading Conditions

Output	MIN	MAX	Units
+12 V	10	11,000	μ F
+5 VSB	1	350	μ F

4 Redundancy Requirements

4.1 Current Sharing Operation

The power supply shall be designed for active current sharing for 12V main output.

Two or more power supplies will be paralleled in a system. Each power supply must be able to share load to be within +/-20 % share error, measured at 25, 50, 100% of single power supply full load current.

4.2 Output Isolation Oring MOSFET

The 12V output current must pass through an Oring MOSFET to protect the bus voltage against a power supply internal fault.

4.3 Hot Swap

The power supply must be designed with "hot swap" function with or without active AC line cord. After Hot swap I2C address shall be same as host power supply backplane hardware assigned. Host existing working power supply shall not be affected by hot swapping power supply.

5 Controls and Signal

5.1 Timing Requirements

These are the timing requirements for the power supply operation.

The output voltages must rise from 10% to within regulation limits (Tvout_rise) within 5 to 70 ms. Each output voltage shall reach regulation within 50 ms (Tvout_on) of each other during turn on of

the power supply. Each output voltage shall fall out of regulation within 400 ms (T_{vout_off}) of each other during turn off. Figure 1 and Figure 2 the turn ON and turn OFF timing requirements. In Figure 2, the timing is shown with both AC and PSON# controlling the ON/OFF of the power supply.

Output Voltage Timing

Item	Description	MIN	MAX	Units
T_{vout_rise}	Output voltage rise time from each main output.	5	70	ms
T_{vout_on}	All main outputs must be within regulation of each other within this time.		50	ms
T_{vout_off}	All main outputs must leave regulation within this time.		400	ms

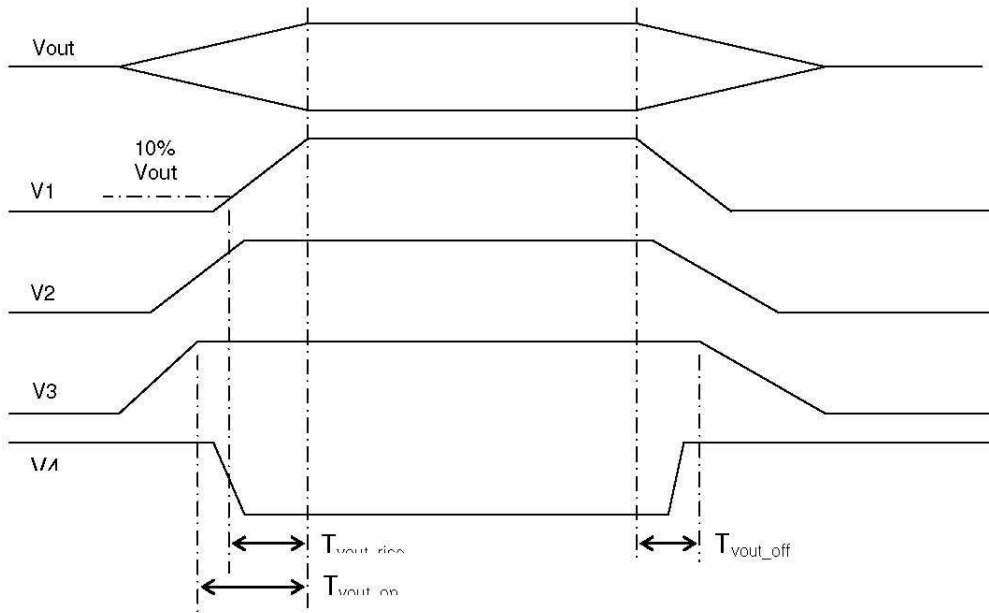

Fig. 1 Output Voltage Timings

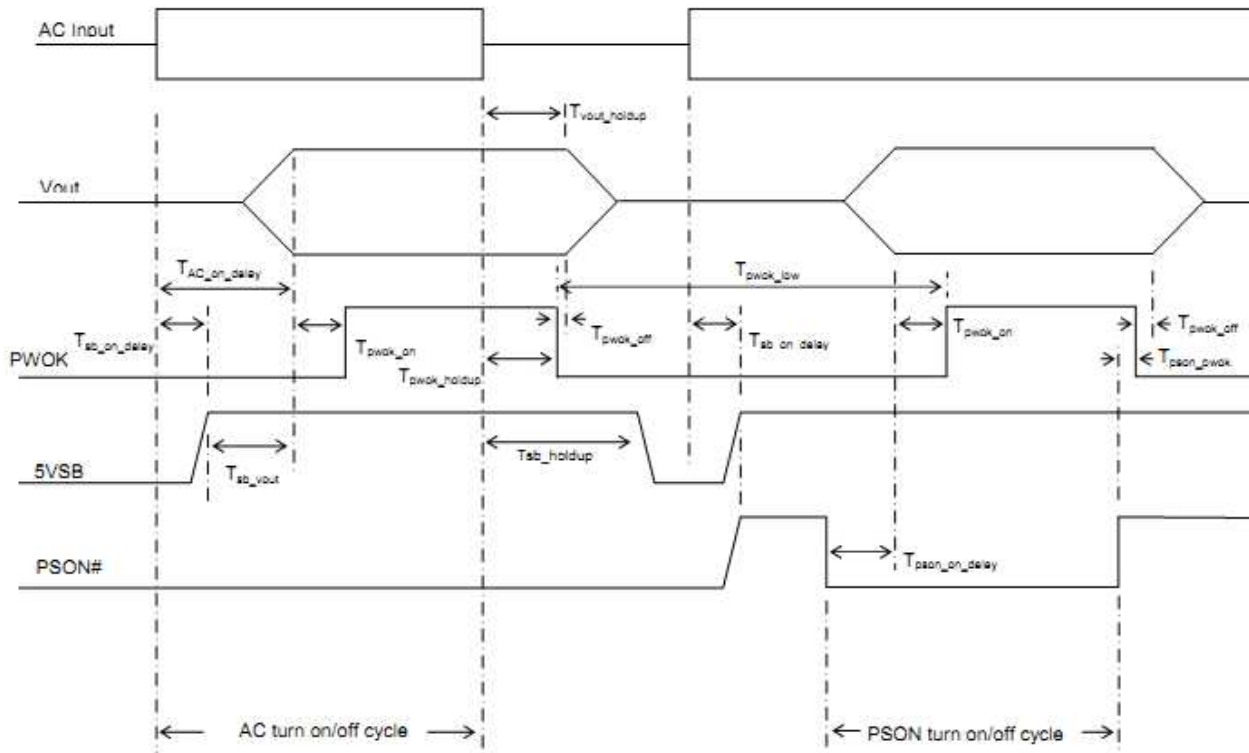

Figure 2: Turn On/Off Timing (Single Power Supply)

Figure 2 Turn On/Off Timing (Single Power Supply)

Item	Description	MIN	MAX	Units
Tsb_on_delay	Delay from AC being applied to 5 VSB being within regulation.		1500	ms
T ac_on_delay	Delay from AC being applied to all output voltages being within regulation.		2500	ms
Tvout_holdup	Time all output voltages stay within regulation after loss of AC. Tested at 75% of maximum load and over 100-240VAC input	17		ms
Tdc_good_holdup	Delay from loss of AC to deassertion of DC Good	16		ms
Tpson_on_delay	Delay from PSON# active to output voltages within regulation limits.	5	400	ms
Tsb_vout	Delay from 5 VSB being in regulation to O/Ps being in	50	500	ms

	regulation at AC turn on.			
Tpson_dc_good	Delay from PSON# deactive to DC Good being deasserted.		50	ms
Tdc_good_on	Delay from output voltages within regulation limits to DC Good asserted at turn on.	100	120	ms
Tdc_good_off	Delay from DC Good deasserted to output voltages dropping out of regulation limits.	1		ms
Tsb_vout	Delay from 5 VSB being in regulation to O/Ps being in regulation at AC turn on.	50	1000	ms
Tsb_holdup	Time 5VSB output voltage stays within regulation after loss of AC.	70		ms
Tsb_Vout_rise	The rising time for +5VSB start up to be in regulation	1	25	ms

5.2 PS_ON

The PSONsignal is required to remotely turn on/off the power supply. PSON is an active low signal that turns on the +12 V power rail. When this signal is not pulled low by the system, or left open, the outputs (except the +5 Vsb) turn off. This signal is pulled to a standby voltage by a pull-up resistor internal to the power supply.

PSON Signal Characteristic

Signal Type	Accepts an open collector/drain input from the system. Pull-up to VSB located in power supply.		
PSON# = Low	ON		
PSON# = Open or High	OFF		
	MIN	MAX	
Logic level low (power supply ON)	0 V	1.0 V	
Logic level high (power supply OFF)	2.0 V	5.25 V	
Source current, Vpson = low		4 mA	
Power up delay:	Tpson_on_delay	5 ms	400 ms
PWOK delay:	Tpson_pwok		50 ms

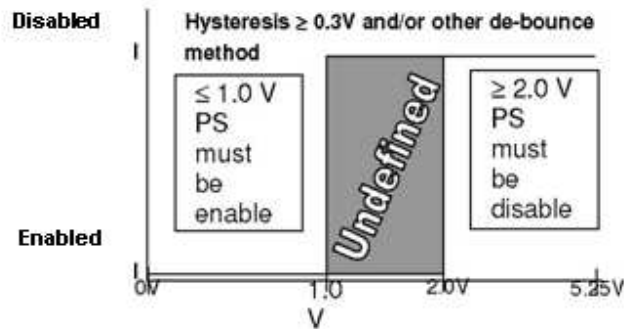

Fig.3 Logic level definition

5.3 PWOK(Power OK is on power distribution board)

PWOK is a power OK signal and will be pulled HIGH by the power supply to indicate that all the outputs are within the regulation limits of the power supply. When any output voltage falls below regulation limits or when AC power has been removed for a time sufficiently long so that power supply operation is no longer guaranteed, PWOK will be de-asserted to a LOW state. For a representation of the timing characteristics of PWOK, The start of the PWOK delay time shall be inhibited as long as any power supply output is in current limit.

PWOK Signal Characteristics

Signal Type	+5V TTL Compatible output signal	
PWOK = High	Power OK	
PWOK = Low	Power not OK	
	MIN	MAX
Logic level low, Isink = 4mA		0.4 V
Logic level high, Isource = 200µA	2.4 V	5.25 V
PWOK delay: T _{pwok_on}	100 ms	300 ms
PWOK rise and fall time		100 µs
Power down delay: T _{pwok_off}	1 ms	

DC GOOD Signal Characteristics

Signal Type	+12V Compatible output signal	
DCGOOD= High	Power OK	
DCGOOD = Low	Power not OK	
	MIN	MAX
Logic level low, Isink = 4mA		0.4 V
Logic level high, Isource = 200µA	9.4 V	12.25 V

DCGOOD delay: T_{dcgood_on}	100 ms	120 ms
DCGOOD rise and fall time		100 μ s

5.4 AC Warning

Noted on PMBus 1.2 standard.

5.5 LED Indicator

A green/amber double color Light Emitting Diode (LED) shall be mounted as indicated in mechanical drawing and shall indicate the status of the DC GOOD signal with green color. The LED shall continue to glow under normal operation of the power supply. If this LED is blinking or not lit or in amber color, the power supply is not operating properly.

During protection mode, the LED should be off.

When protection is cleared, the LED should go back to the original intended status.

When the unit is in standby with AC is present, the LED should be amber.

When the unit is in standby with no AC is present, the LED should be off.

When the unit is turned on properly, the LED is green.

6. I²C and PMBusTM 1.2 standard.

This power supports both I2C function and PMbus. With different addressing, the user should able to use either I2C FRU or PMbus commands.

I2C Signal Connector Pin Definition

Pin	Signal	24 AWG Color
1	SMBus Clock	White/Green Stripe
2	SMBus Data	White/Yellow Stripe
3	SMBAlert	Red
4	No connect	
5	No connect	

6.1 I2C

Slave address will be 0x70 (default), 0x72, 0x74, 0x76

For non-redundant power supply, the slave address for I2C function should be 0x70.

System addressing Address1 (A1) /Address0 (A0)	0/0	0/1	1/0	1/1
Power supply I2C slave address	70h	72h	74h	76h

The power supply can be read and written to as if it's a 2k bit (256 byte) I2C EEPROM. The power supply must support: Byte write and Random read. Read and write must work at speeds up to 100 kHz. This bus shall operate at nominal voltage 3.3V but be tolerant of 5V signaling.

All the data stored in the power supply follows FRU spec, IPMI, Platform Management FRU information Storage Definition v1.0.

FRU spec attached below:

The "Chassis Info" and "Board Info" are not to be implemented. The "Common Header" and "Product Area" are required.

For the "Multiple Record" area, the power supply should implement the "Power Supply Information", and multiple "DC Output" section as needed.

For the "Product Info" area must began from offset location 0x18 (offset 0x04 product information offset must contains value of 0x03).

The "Internal Use" section as follows:

Offset		Result of a read
0x09	Temperature (hot spot)	Value to represent the current temperature of the hottest spot inside the power supply This is an unsigned integer value in Celsius.
0x0A	Fan 1 speed (main fan)	Value to represent the RPM of the power supply fan #1 This should be the fan pulse count in 262 ms. We are assuming that two fan pulses equal one rotation. The system software will convert this value, to fan RPM, using: $RPM=(1/0.262) * (Fan\ Pulse\ Count * 60 / 2)$
0x0B	Fan 2 speed (secondary fan if available)	Value to represent the RPM of the power supply fan #1 This should be the fan pulse count in 262 ms. We are assuming that two fan pulses equal one rotation. The system software will convert this value, to fan RPM, using: $RPM=(1/0.262) * (Fan\ Pulse\ Count * 60 / 2)$ If fan 2 is not available, default value 0x00

0x0C	Power Status	Value to represent DC GOOD status byte = hex 01 means DC GOOD byte = 00 means no DC output
0x0D	Temperature High Limit (hot spot)	Value is fixed and should be the highest acceptable temperature that the power supply can sustain based on offset 09. This value is for information display purpose only and is independent from protection or fan control design. Modifying this byte will not affect the power supply operation.
0x0E	Fan 1 speed Low Limit	Value is fixed and should be the lowest fan #1 RPM acceptable. This value is for information display purpose only and is independent from protection or fan control design. Modifying this byte will not affect the power supply operation.
0x0F	Fan 2 speed Low Limit (if secondary fan is available)	Value is fixed and should be the lowest fan #2 RPM acceptable. If fan 2 is not available, default value 0x00. This value is for information display purpose only and is independent from protection or fan control design. Modifying this byte will not affect the power supply operation.
0x14	AC RMS current	This byte, divided by 16, is the AC (RMS) input current.
0x15	DC output current (optional)	This byte is the DC output current. If this function is not available, default value is 0x00
0x16	Firmware version	Example: version 2.0 is encoded as 0x20 Anything less than 2.0 (0x20) found at this location will be reported as version 1.0 Default initial value 0x10
0x17	FRU file revision	Integer only
0xF0	AC current limit	AC current upper limit; This byte, divided by 16, is the AC input current limit This value is for information display purpose only and is independent from protection or control logic design. Modifying this byte will not affect the power supply operation.
0xF1	+12V DC current limit	+12V DC current upper limit; this byte is the DC (+12V) output current. This value is for information display purpose only and is independent from protection or control logic design. Modifying this byte will not affect the power supply operation.
0xF2	Power supply output wattage rating	Power supply output wattage rating; lower byte. If the output wattage changes according to different AC input voltage range, this output should reflect accordingly.
0xF3	Power supply output wattage rating	Power supply output wattage rating; higher byte. If the output wattage changes according to different AC input voltage range, this output should reflect accordingly.
0xF4	Input voltage	100-240Vac input voltage reading (for readings above 255Vac, it

		should report 255Vac)
0xF5	Real time Input power (lower byte)	Real time Input power in watt (lower byte) (example 0x01F4=500W)
0xF6	Real time Input power (higher byte)	Real time Input power in watt (higher byte)
0xFF	Write protection Control	<p>This byte controls whether the FRU is writeable or read only. When this byte content is 0x88, the FRU is writeable. Otherwise, only byte 0xFF can be modified.</p> <p>value= 0x88 is FRU writeable mode Any other value, FRU is read only except address 0xFF can be modified. Default value for this byte is read only, 0x00.</p> <p>After AC Lost or power on/off, this byte should not be reset and should remain to whatever the latest previous value is.</p>

The power supply will support the “byte write” procedure defined in the I2C EEPROM spec.

Read only bytes --- writes to the following bytes should be ignored:

Offset	
0x09	Temperature
0x0A	Fan 1 speed (main fan)
0x0B	Fan 2 speed (secondary fan if available)
0x0C	Power Status
0x14	AC RMS current
0xF4	Input voltage
0xF5	Real time Input power (lower byte)
0xF6	Real time Input power (higher byte)

I2C auto-recovery feature:

In a normal I2C transaction, there will be 8 bytes of transmission plus an ACK (acknowledge) byte, for a total of 9 clock cycles. ACK is done by pulling down the SDA line. If there is a missing clock cycle, the chip doing the ACK will hold down the SDA line indefinitely and hanging the I2C bus. The power supply needs to prevent the above scenario from happening. If the I2C bus SDA or SCL is stuck low for more than 25 ms, the power supply should reset either its I2C communication module, or itself.

The power supply I2C microcontroller should not latch the system I2C bus by pulling SDA or SCL line low for more than 25 ms.

The power supply needs to have 4.7k Ohm internal pull up on the SDA or SCL lines and operate with 3.3V nominal voltage level.

6.2 PMBus

The PMbus specification is based on the PMBus specification parts I and II, revision 1.1 and 1.2. PMBus Power System Management Protocol Specification Part I – General Requirements, Transport and Electrical Interface; Revision 1.2; Reference: <http://pmbus.org/specs.html>

PMBus Power System Management Protocol Specification Part II – Command Language; Revision 1.2; Reference: <http://pmbus.org/specs.html>

System Management Bus (SMBus) Specification version 2.0; Reference: <http://smbus.org/specs/>

6.2.1 Addressing

The power supply PMbus device address locations are shown below. For redundant systems there are up to 2 signals to set the address location of the power supply once it is install in the system: A1, A0. For no-redundant systems the power supply device address location should be 78h.

System addressing Address1 (A1) /Address0 (A0)	0/0	0/1	1/0	1/1
Power supply PMBus™ device	78h	7Ah	7Ch	7Eh

Note: Non-redundant power supplies will use the 0/0 address location, 78h.

6.2.2 Command

The following PMBus commands shall be supported for the purpose of monitoring currents, voltages, and power. All data should use the linear data format as documented in PMbus spec.

<u>PMBus command</u>	<u>Command Offset location</u>	<u>Byte size</u>	<u>Description</u>
<u>CLEAR_FAULTS</u>	0x03	1	Writing any value into this byte will reset all the fault status
<u>PAGE_PLUS_WRITE</u>	0x05	variable	used with STATUS_INPUT, STATUS_TEMPERATURE, STATUS_IOUT

<u>PAGE_PLUS_READ</u>	0x06	Variable	used with STATUS_INPUT, STATUS_TEMPERATURE, STATUS_IOUT, STATUS_WORD
CAPABILITY	0x19	1	Provides a way for a host system to determine some key capabilities of a PMBus device
QUERY	0x1A	1 with block write read	Used to determine if the power supply supports a specific command
SMBALERT_MASK	0x1B	Variable	Used to prevent a warning or fault condition from asserting the SMBALERT# Signal. The masks can be changed by user.
VOUT_MODE	0x20	1	determines the format of Voltage output (Linear, direct, or VID), also set the mantissa
COEFFICIENT	0x30	5 with block write read	The system shall use this to read the values of m, b, and R used to determine READ_EIN accumulated power values.
FAN_CONFIG_1_2	0x3A	1	Returns the configuration of Fan 1 and Fan 2 in the power supply
FAN_COMMAND_1	0x3B	2	Allows system to request fans in the power supply to be set to the defined duty cycle. The system cannot cause the power supply fan to run slower than the power supply needs for cooling. This data should be in linear format. Example (32h=50% duty, 64h=100% Duty).
FAN_COMMAND_2	0x3C	2	Allows system to request fans in the power supply to be set to the defined duty cycle. The system cannot cause the power supply fan to run slower than the power supply needs for cooling. This data should be in linear format. Example (32h=50% duty, 64h=100% Duty)
STATUS_BYTE	0x78	1	command to report the On/off status of the power supply. Please refer to page 72 of PMbus spec part 2
STATUS_WORD	0x79	2	command to report the 2byte status of the power supply. Please refer to page 74 of PMbus spec part 2
STATUS_IOUT	0x7B	1	command to report the output current status
STATUS_INPUT	0x7C	1	command to report the input voltage and current status
STATUS_TEMPERATURE	0x7D	1	command to report the device temperature

			status
STATUS_FANS_1_2	0x81	1	command to report the fan status
READ_EIN	0x86	6 with block read	Command to report the accumulated input power (Total power usage since AC on)
READ_VIN	0x88	2	RMS input voltage in volts(note; not used on power distribution boards) Should reset to 0 when AC is lost
READ_IIN	0x89	2	RMS input current in amps (note; not used on power distribution boards) Should report 0 when AC is lost or in standby
READ VOUT	0x8B	2	12V Output Voltage (should reset to 0 during standby or AC is removed)
READ IOUT	0x8C	2	12V Output Current (should reset to 0 during standby or AC is removed)
READ_TEMPERATURE1 (Ambient)	0x8D	2	Read airflow inlet temperature (should be similar to the ambient temperature)
READ_TEMPERATURE2 (hot Spot)	0x8E	2	Read hotspot temperature (should be the hottest location inside the unit)
READ_FAN_SPEED_1	0x90	2	Returns the fan speed in RPM of fan sensor 1. This data should be in linear format
READ_FAN_SPEED_2	0x91	2	Returns the fan speed in RPM of fan sensor 2. This data should be in linear format
READ POUT	0x96	2	12V DC Output in Watts
READ PIN	0x97	2	AC input power in watts (note; not used on power distribution boards). Value should reset to 0W when in standby mode or AC is lost.
PMBUS_REVISION	0x98	1	Reads the revision of the PMBus to which the device is compliant (default value 22h)
APP_PROFILE_SUPPORT	0x9F	2 with block read	Defines that the power supply supports this application profile (default profile 04h), profile revision 1.0, (default revision value 10h)
MFR_VIN_MIN	0xA0	2	Retrieves the minimum rated value, in volts, of input voltage (ex. 90Vac). This value remains a constant value.
MFR_VIN_MAX	0xA1	2	Retrieves the maximum rated value, in volts, of input voltage (ex. 264Vac). This value is a constant value.

MFR_PIN_MAX	0xA3	2	Retrieves the maximum rated value, in watts, of input power. If there is a high line or low line input power difference, the suitable input max power should be displayed properly. (ex. Power supply with rating 1005W @100-120Vac, 1205W @120-140Vac. During 100-120Vac, $MFR_PIN_MAX = (1005W + 10W \text{ fan DC power}) / 0.88 \text{ efficiency} = 1153W$. During 120-140Vac, $MFR_PIN_MAX = (1205W + 10W \text{ fan DC power}) / 0.9 \text{ efficiency} = 1350W$)
MFR_IOUT_MAX	0xA6	2	Retrieves the maximum rated 12V output current
MFR_POUT_MAX	0xA7	2	Retrieves the maximum rated value, in watts, of output power. If there is a high line or low line input power difference, the suitable input max power should be displayed properly. (ex. Power supply with rating 1005W @100-120Vac, 1205W @120-140Vac. MFR_POUT_MAX should display 1005W or 1205W according to Vac input.
MFR_TAMBIENT_MAX	0xA8	2	Retrieves the maximum rated ambient temperature, in degree C, in which the unit might be operated. This value is a constant value. (default 50 Degree C)
MFR_TAMBIENT_MIN	0xA9	2	Retrieves the minimum rated ambient temperature, in degree C, in which the unit might be operated. This value is a constant value. (Default 0 Degree C)
MFR_MAX_TEMP_1 (Ambient)	0xC0	2	This defines the maximum inlet temperature to generate a warning condition in the STATUS_TEMPERATURE command. This value is a constant value. Default value 50 Degree C.
MFR_MAX_TEMP_2 (hot spot)	0xC1	2	This is the trip threshold for the hotspot temperature sensor (TEMP2) to asset SMBAAlert#. This defines the maximum hotspot temperature to generate a warning condition in the STATUS_TEMPERATURE command. This value is a constant value. Default value setting: over temperature point minus 4 degree C.

VOUT_MODE Command Definition:

For reading output voltages the power supply shall support the VOUT_MODE command to report the output voltage formatting for the READ_VOUT command. The VOUT_MODE shall be set to Linear and the exponent (N) shall be set to -9.

VOUT_MODE settings for reading output voltage(s).

Mode	Bits [7:5]	Bits [4:0] (N)
Linear	000b	10111b (-9)

FAN_COMMAND_1_2 Command Definition:

The system may increase the power supplies fan speed through using the FAN_COMMAND Command. This command can only increase the power supply fan speed; it cannot decrease the power supply fan speed below what the power supply commands.

The control is configured to be duty cycle controlled using the linear format of the PMBus protocol.

The exponent N is fixed to a value of 0 (N=0). The command ranges from value 0000h (0% duty) to 0064h (100% duty).

STATUS Commands:

The following PMBus STATUS commands shall be supported. All STATUS commands except the STATUS_FAN_1_2 and STATUS_BYTE commands shall be accessed with the PAGE_PLUS command since they are used by both the BMC and ME. The (BMC) and (ME) refer to the two instances of the command accessed via the PAGE_PLUS command. The status bits shall assert whenever the event driving the status bit is present. Once a bit is asserted it shall stay asserted until cleared using one of the five methods described below:

- 1) Writing a '1' to any given bit location shall reset on that bit of the command
- 2) Sending a CLEAR_FAULTS command to the power supply shall reset all STATUS_ bits to '0'
- 3) Cycling AC power OFF(when Vin below 90Vac) than ON (when Vin above 90Vac) shall reset all STATUS_ bits to '0'.

- 4) Systems with redundant power supplies where only one of the supplies cycle AC power OFF/ON; the power cycled power supply shall reset the STATUS_ bits to '0' only when powered back ON. If the power supply is kept OFF, the STATUS_ bits shall not be reset.
- 5) Cycling the PSON# signal from de-asserted to asserted shall reset the STATUS_ bits to '0'. The bits shall be reset only on the assertion of PSON#; not the de-assertion.

STATUS_BYTE: Please refer to PMbus part 2 Spec.

Offset 0x78		PAGES 00h=BMC 01h=ME	SMBAlert_MASK Default (0=causes assertion of SMBAlert#, 1=does not cause assertion of SMBAlert#) STATUS_Byte SMBAlert Mask is not user changeable	
Bit #	7	Not used, default=0	00h, 01h	1
	6	Device is off due to PSON or for any reason (ex. Protection)=1, else 0	00h, 01h	1
	5	Output OVP fault=1, else 0	00h, 01h	1
	4	Output OCP fault =1, else 0	00h, 01h	1
	3	Vin under voltage fault =1, else 0	00h, 01h	1
	2	OTP fault =1; else 0	00h, 01h	1
	1	CML communication error=1, else 0	00h, 01h	1
	0	Other fault (A fault or warning not listed in bit [7:1] of this byte has occurred)=1, else=0	00h, 01h	1

STATUS_WORD: Please refer to PMbus part 2 Spec.

Byte	STATUS_WORD, Offset 0x79		PAGES 00h=BMC 01h=ME	SMBAlert_MASK Default (0=causes assertion of SMBAlert#, 1=does not cause assertion of SMBAlert#) STATUS_Word SMBAlert Mask is not user changeable
Low	7	Not used, default=0	00h, 01h	1
	6	Device is off due to PSON or for any reason (ex. Protection)=1, else 0	00h, 01h	1

	5	Output OVP fault occur=1, else 0	00h, 01h	1
	4	Output OCP fault occur =1, else 0	00h, 01h	1
	3	Vin under voltage fault occur =1, else 0	00h, 01h	1
	2	OTP fault occur=1; else 0	00h, 01h	1
	1	CML communication error=1, else 0	00h, 01h	1
	0	Other Fault (A fault or warning not listed in bit [7:1] of this byte has occurred)=1, else=0	00h, 01h	1
High	7	VOUT Fault or warning=1, else 0	00h, 01h	1
	6	IOUT/POUT fault or warning=1, else 0	00h, 01h	1
	5	An input voltage, input current, or input power fault or warning=1, else 0	00h, 01h	1
	4	Not used, default=0	00h, 01h	1
	3	Power Good signal is not good (logic low)=1, else 0	00h, 01h	1
	2	Fan fault or warning=1, else 0	00h, 01h	1
	1	Not used, default=0	00h, 01h	1
	0	Not used, default=0	00h, 01h	1

STATUS_IOUT Command Definition:

Bit	STATUS_IOUT, Offset 0x7B	PAGES 00h=BMC 01h=ME	SMBAAlert_MASK Default (0=causes assertion of SMBAAlert#, 1=does not cause assertion of SMBAAlert#)
7	IOUT Overcurrent Fault	00h, 01h	1
6	Not used, default=0	00h, 01h	1
5	IOUT Overcurrent Warning (greater than rated output current for more than 1second)	00h, 01h	1
4	Not used, default=0	00h, 01h	1
3	Not used, default=0	00h, 01h	1
2	Not used, default=0	00h, 01h	1
1	POUT Overpower Fault	00h, 01h	1

0	POUT Overpower Warning (greater than rated output power for more than 1 second)	00h, 01h	1
---	---	----------	---

STATUS_INPUT Command Definition:

Bit	STATUS_INPUT, Offset 0x7C	PAGES 00h=BMC 01h=ME	SMBAlert_MASK Default (0=causes assertion of SMBAlert#, 1=does not cause assertion of SMBAlert#)
7	VIN Over voltage Fault (Vin>265Vac for more than 1 sec)	00h, 01h	1
6	VIN Over voltage Warning (Vin>245Vac for more than 1 sec)	00h, 01h	1
5	Vin Under voltage Warning (Vin<88Vac for more than 1 sec)	00h, 01h	1 Page 00h=1; Page 01h=0
4	Vin Under voltage Fault (Vin< 80Vac. For Vin<10Vac, this bit should be raised within 2ms)	00h, 01h	
3	Unit is off for insufficient Input Voltage (Input UVP)	00h, 01h	1
2	IIN Over current Fault (When unit is shut down due to input over current)	00h, 01h	1
1	IIN Over current Warning (When IIN over IO label input current max rating for more than 1 second)	00h, 01h	1
0	Not used, default=0;	00h, 01h	1

STATUS_TEMPERATURE Command Definition:

Bit	STATUS_TEMPERATURE, Offset 0x7D	PAGES 00h=BMC 01h=ME	SMBAlert_MASK Default (0=causes assertion of SMBAlert#, 1=does not cause assertion of SMBAlert#)
7	Overtemperature Fault (When Over temperature protection is triggered)	00h, 01h	1
6	Overtemperature Warning (When READ_TEMPERATURE2 exceed MFR_MAX_TEMP_2)	00h, 01h	Page 00h=1; Page 01h=0
5	Undertemperature Warning (When Ambient temperature is less than -1 degree C for more than 1 sec)	00h, 01h	1

4	Undertemperature Fault (When unit is unable to turn on due to low ambient temperature)	00h, 01h	1
3	Not used, default=0;	00h, 01h	1
2	Not used, default=0;	00h, 01h	1
1	Not used, default=0;	00h, 01h	1
0	Not used, default=0;	00h, 01h	1

STATUS_FANS_1_2 Command Definition:

Bit	STATUS_FANS_1_2, Offset 0x81	PAGES 00h=BMC 01h=ME	SMBAlert_MASK Default (0=causes assertion of SMBAlert#, 1=deso not cause assertion of SMBAlert#)
7	Fan 1 Fault=1, else=0	N/A	1
6	Fan 2 Fault=1, else=0	N/A	1
5	Not used, default=0;	N/A	1
4	Not used, default=0;	N/A	1
3	Fan 1 Speed Overridden (When User command is applied)=1; else 0	N/A	1
2	Fan 2 Speed Overridden (When User command is applied)=1; else 0	N/A	1
1	Not used, default=0;	N/A	1
0	Not used, default=0;	N/A	1

PMBUS_REVISION Command Value:

Bits 7:4	Part I Revision	Bits 3:0	Part II Revision
0010	1.2	0010	1.2

APP_PROFILE_SUPPORT Command:

The Block Read/Write protocol is used with this command.

First Byte for supporting Romley Profile: 04h

Second Byte for supporting Romley Profile rev 1.0: 10h

6.2.3 Manufacturer Specific Commands:

Offset 0xD0-0xDE is used to represent the unit model serial number. Data represented in byte format.

These bytes are read/write capable through I2C

Below serial number is for example only:

Offset	Serial number	
	character	Hex
D0	P	
D1	1	
D2	6	
D3	2	
D4	1	
D5	M	
D6	Y	
D7	W	
D8	W	
D9	R	
DA	M	
DB	S	
DC	S	
DD	S	
DE	S	

Offset 0xE0 – 0xEB is used to represent the model number, data represented in byte format.

These bytes are read/write capable through I2C.

Offset	Item number	
	character	Hex
E0	C	
E1	P	
E2	R	
E3	1	
E4	6	
E5	2	
E6	1	
E7	-	
E8	1	
E9	M	
EA	2	
EB	1	

Additional information bytes for FRU backward compatibility. These bytes are read/write capable.

Offset	Function	Description
--------	----------	-------------

ED	Temperature upper limit	Internal temperature upper limit in degree Celsius. Direct data format, data length is one byte.
EE	Fan 1 pulse count lower limit	Value to represent the lower limit RPM of the power supply fan #1 The system software will convert this value, to fan RPM, using: RPM limit=(1/0.262) *(Fan Pulse Count limit * 60 /2)
EF	Fan 2 pulse count lower limit	Value to represent the lower limit RPM of the power supply fan #2 The system software will convert this value, to fan RPM, using: RPM limit=(1/0.262) *(Fan Pulse Count limit * 60 /2)

Offset 0xF0-0xF5 is used to represent the unit revision number. Revision begins with Rev 1.0. Data is represented in byte format. These bytes are read/write capable using I2C.

Offset	Revision	
	character	Hex
F0	R	
F1	E	
F2	V	
F3	1	
F4	.	
F5	0	

6.2.4 Sensor Sampling

The sensor registers inside the power supply for monitoring input/output power, current, and voltage shall meet the following minimum requirements. Register refresh rate is the frequency the sensor register gets updated with a new measurement value.

Register refresh rate \geq 10Hz

6.2.5 Sensor Averaging

The sensor registers for monitoring input/output power, current, and voltage shall contained averaged data, not instantaneous peak data. This may be achieved in two ways; an arithmetic average or a low pass filter. An exponential moving average shall not be used. The power supply

shall refresh the sensor data at a rate no slower than the averaging duration.

READ_PIN, shall be an average value over a 2 second interval.

READ_IIN and READ_VIN shall be an RMS value over a 2 second interval.

6.2.6 Accuracy

The sensor commands shall meet the following accuracy requirements.

		10% of max load	20% of max load	50% of max load	100% of max load
READ_IIN		+/-5%	+/-5%	+/-5%	+/-2%
READ_PIN		+/-5% or +/- 10W (which ever tolerance is larger)	+/-5%	+/-5%	+/-5%
READ_IOUT		+/-5%	+/-3%	+/-5%	+/-3%
READ_POUT		+/-5% or +/- 10W (which ever tolerance is larger)	+/-5%	+/-5%	+/-5%
READ_VIN	+/- 2% over full range				
READ_VOUT	+/- 2% over full range				
READ_TEMPERATURE	Required: +/-3 °C				

6.3 SMBAlert

The SMBAlert# Signal may be asserted (pulled low, less than 0.4V) by the power supply for any of the supported STATUS events. The events that control SMBAlert# can be masked during the SMBALERT_MASK command. Default masking is shown the status command definitions.

By default the SMBAlert# signal is asserted for the following cases:

- 1) AC Input voltage drops below the fault threshold (<10Vac) for more than 2ms.
- 2) Thermal sensor on a hot spot inside the power supply has exceeded its warning temperature (MFR_MAX_TEMP2)
- 3) Power supply is turned off due to PSON

The power supply does not support Alert Response Address (ARA). After asserting the SMBAlert# signal, the power supply shall keep its address at its standard address; not change to

18h.

The SMBAlert# signal shall be asserted whenever any un-masked event has occurred. This is a level detected event. Whenever the event is present SMBAlert# shall be asserted. If the SMBAlert signal is cleared, it shall immediately re-asserted if the event is still present.

The SMBAlert# signal shall be cleared and re-armed by the following methods:

- 1) Clearing STATUS bits causing the asserted SMBAlert# signal.
- 2) Power cycling with PSON or with AC power
- 3) Using CLEAR_FAULTS command that clears all fault
- 4) Cycling AC power OFF(when Vin below 90Vac) than ON (when Vin above 90Vac) shall reset the SMBAlert#
- 5) Systems with redundant power supplies where only one of the supplies cycle AC power OFF/ON; the power cycled power supply shall reset the SMBAlert# only when the device is powered back ON. If the power supply is kept OFF, the SMBAlert# shall not be reset.

During Standby mode or AC off (both single or redundant mode), SMBAlert# should be logic low (less than 0.4V) and be able to sink 4mA current.

SMBAlert# logic high nominal voltage should be 5V.

SMBAlert# Logic Level

	MIN	MAX	Nominal
Logic level low voltage, Isink = 4mA	0V	0.4V	0V
Logic level high voltage, Isource = 200µA	2.4V	5.25V	5V

AC ON condition SMBAlert timing sequence

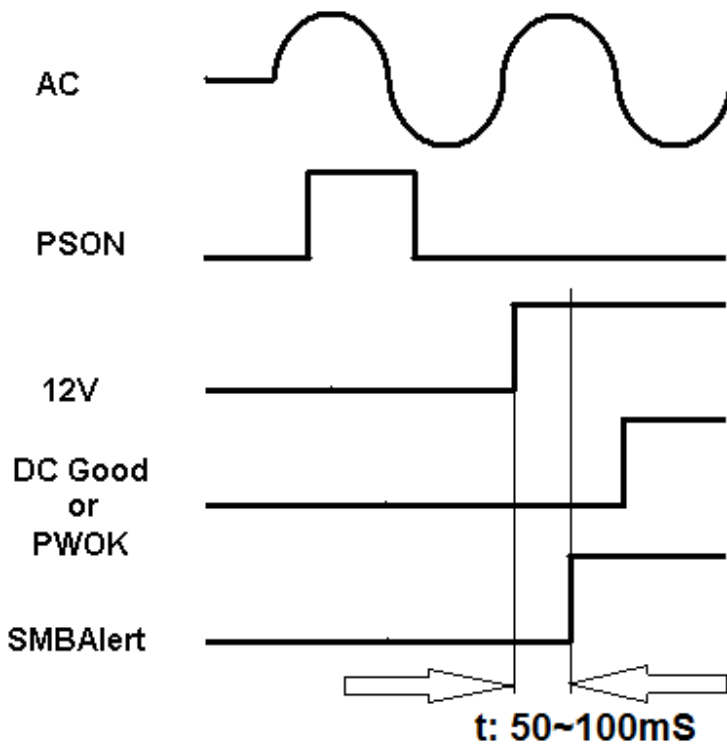

PSOn=off power down condition (AC always ON) SMBAAlert timing sequence

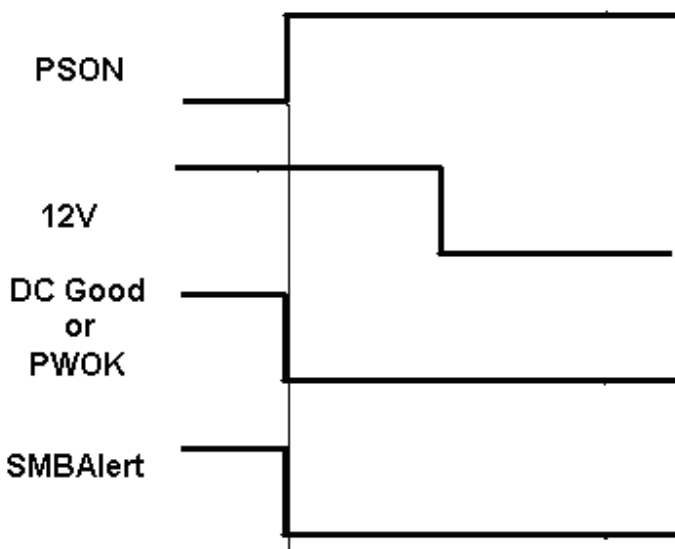

Power down condition due to AC OFF SMBAAlert timing sequence

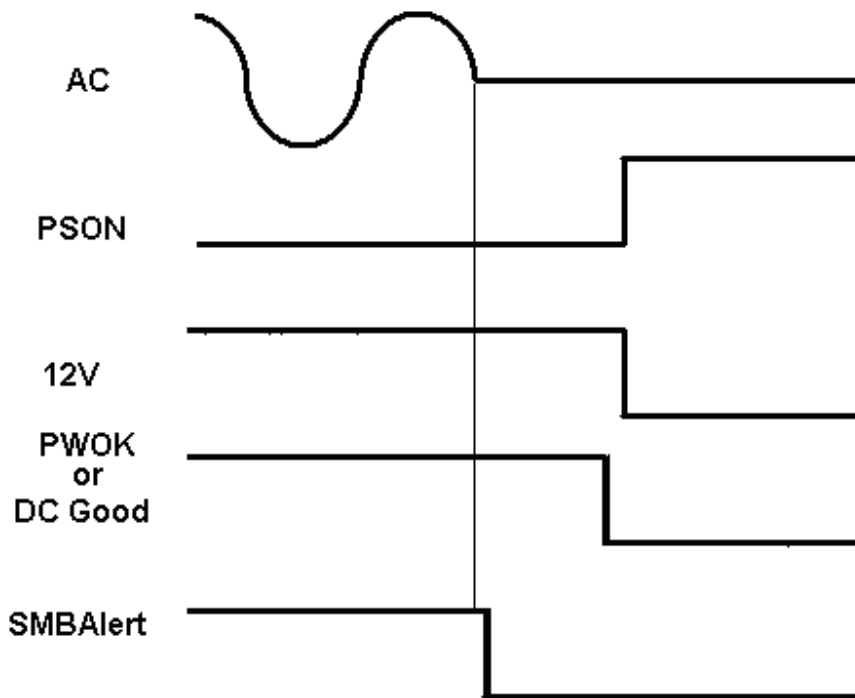

AC Loss within hold up time, SMBAlert will be triggered during AC Loss. SMBAlert will return to nominal after AC voltage is resumed.

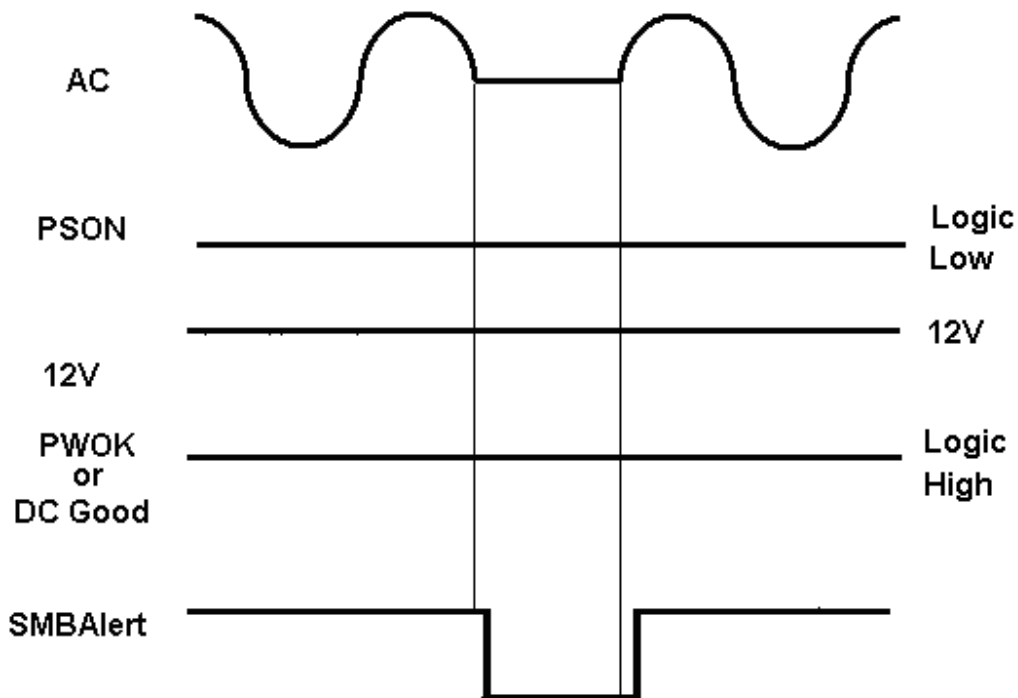

6.4 Faults and Error Checking

The power supply shall support PEC(packet error checking) per the SMBus 2.0 specification. The power supply shall also support and respond to commands which do not contain PEC(packet error checking).

7 Protection Circuits

Protection circuits inside the power supply shall cause only the power supply’s main outputs to shutdown. If the power supply latches off due to a protection circuit tripping, an AC cycle OFF for 15 seconds and a PSON cycle HIGH for 1 second shall be able to reset the power supply.

7.1 Over Current Protection

The power supply shall have current limit to prevent +12 V outputs from exceeding the values shown in below table. If the +12V current limits are exceeded the power supply shall shutdown and latch off. The latch will be cleared by toggling the PSON signal or by an AC power interruption. The power supply shall not be damaged from repeated power cycling in this condition. +5 VSB shall be protected under over current or shorted conditions so that no damage can occur to the power supply. All outputs shall be protected so that no damage occurs to the power supply under a shorted output condition.

Over Current Protection

Voltage	Over Current Limit (Iout limit)
+12 V	110% minimum; 150% maximum
+5Vsb	110% minimum; 200% maximum

7.2 240VA Protection

Not applicable

7.3 Over Voltage Protection

The power supply over voltage protection shall be locally sensed. The power supply shall shutdown and latch off after an over voltage condition occurs. This latch shall be cleared by toggling the PSON signal or by an AC power interruption. Below table contains the over voltage limits. The values are measured at the output of the power supply’s connectors. The voltage shall never exceed the maximum levels when measured at the power pins of the power supply connector during any single point of fail. The voltage shall never trip any lower than the minimum levels when measured at the power pins of the power supply connector.

Over Voltage Limits

Output Voltage	MIN (V)	MAX (V)
+12 V	13.3	14.5
+5 VSB	5.7	6.5

7.4 Over Thermal Protection

The power supply over thermal protection shall be locally sensed. The power supply shall shutdown and latch off after an over required temperature condition occurs. This latch shall be cleared by toggling the PSON signal or by an AC power interruption. The over thermal limits that power supply which components contain required maximum temperature. The temperature shall never exceed the maximum levels when measured at the individual component.

7.5 Short Circuit Protection

+12V outputs shall be protected and into latch off mode so that no damage occurs to the power supply under a shorted output condition. This latch shall be cleared by toggling the PSON signal or by an AC power interruption. +5Vsb should be protected and into hiccup mode. No damage occurs to the power supply under a shorted output condition, and should be output normally after shorted output released.

+5Vsb outputs shall be protected and into hiccup mode so that no damage occurs to the power supply under a shorted output condition. No damage occurs to the power supply under a shorted output condition, and should be output normally after shorted output released.

8. Fan Speed Control

When AC plug in, Fans will be on and have minimum speed to cooling power supply to keep normal operating temperature. The power supply will have internally controlled PWM fans. The PWM fans will be thermal controlled by microcontroller. Note that speed transition should be non-linear to reduce perceived noise from fan.

Fan control speed rule is shown in the attached file below.



PWM Fan Control
Design Guideline 0.1.1

9. Mechanical

All dimensions are in mm unit.

W: 76 +/-0.5

L: 360 +/-0.5

H: 40.25 +/-0.5 (Front, AC inlet side), H39.5 +/-0.5 (back, gold finger side)

10. Output Connector and Dimension

The power supply will provide a card edge connector compatible with the backplane. See power supply mechanical drawing for dimensions. The power supply connector is a **23 pair (46 pin)** edge connection type from FCI connector or equivalent.

Power and Signal Connection

Description	Pin Number	I/O	Active	Pin Length
+12V	1		Power Pin	Standard
+12V	2		Power Pin	Standard
Ishare	3		Analog	Standard
A1 (address)	4	I/O	High/Low	Standard
A2 (address)	5	I/O	High/Low	Standard
I2C SCL	6	I/O	High/Low	Standard
I2C SDA	7	I/O	High/Low	Standard
PS ON/OFF	8	I	Low	Short (by 1mm)
SMBAAlert	9	O (+5V)	High/Low	Standard
DC GOOD	10	O (+12V)	High	Standard
+12V	11		Power Pin	Standard
+12V	12		Power Pin	Standard
+12V	13		Power Pin	Standard
+12V	14		Power Pin	Standard
+12V	15		Power Pin	Standard
+12V	16		Power Pin	Standard
+12V	17		Power Pin	Standard
+12V	18		Power Pin	Standard
+12V	19		Power Pin	Standard
+12V	20		Power Pin	Standard
+12V	21		Power Pin	Standard
+12V	22		Power Pin	Standard
+12V	23		Power Pin	Standard
DC Return	24		Power Pin	Standard

DC Return	25		Power Pin	Standard
RS GND	26		Analog	Standard
Spare	27			
12V RS GND	28		Analog	Standard
Fan Control	29	I	High	Standard
DC Return	30		Power Pin	Standard
5Vsb CO	31		Power Pin	Standard
5Vsb CO	32		Power Pin	Standard
DC Return	33		Power Pin	Standard
DC Return	34		Power Pin	Standard
DC Return	35		Power Pin	Standard
DC Return	36		Power Pin	Standard
DC Return	37		Power Pin	Standard
DC Return	38		Power Pin	Standard
DC Return	39		Power Pin	Standard
DC Return	40		Power Pin	Standard
DC Return	41		Power Pin	Standard
DC Return	42		Power Pin	Standard
DC Return	43		Power Pin	Standard
DC Return	44		Power Pin	Standard
DC Return	45		Power Pin	Standard
DC Return	46		Power Pin	Standard

Connector in PDB:

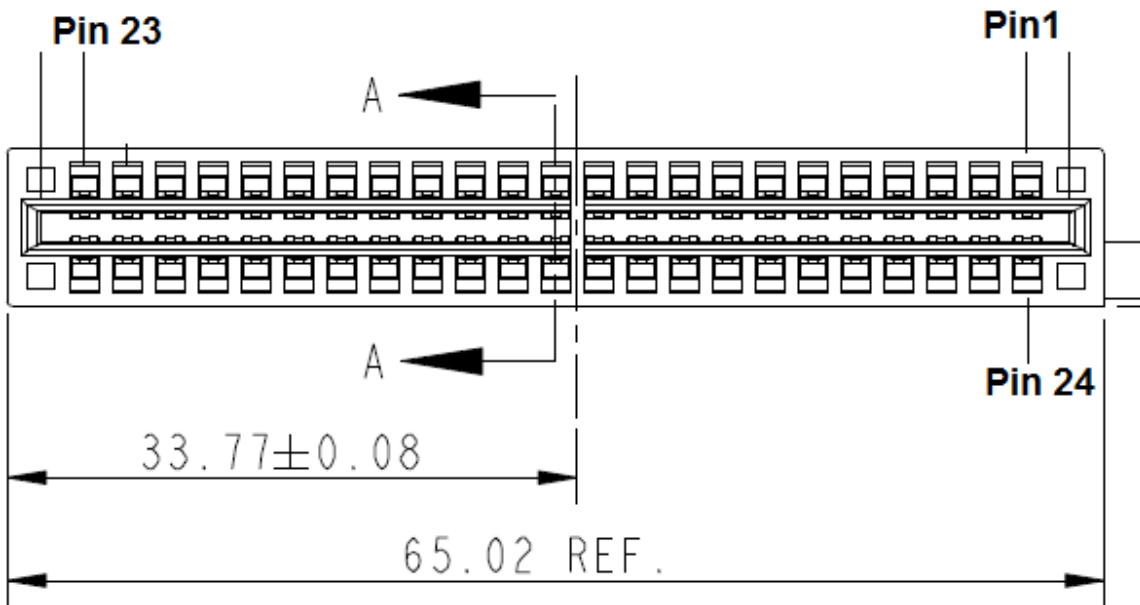

11. MTBF and Quality Data

The life requirement shall be met the following condition. And the environmental temperature is assumed to be 25 degrees Celsius. Normal operation (at the rated input/output): 150,000h.

12. Safety

12.1 Dielectric Strength Testing (Hi-pot)

All units must pass a 1500VAC line to ground/chassis Hi-Pot test in production lines. The voltage must be maintained at that level for a minimum of 3 seconds without failure.

12.2 Ground Continuity Testing

All units must pass a ground continuity test with less 0.1 Ohm from the ground (third wire) input pin to the chassis.

12.3 Agency Requirements

The power supply must comply with all regulatory requirements for its intended geographical market as computer server of Information Technology Equipment.

The power supply must meet all regulatory requirements for the intended market at the time of manufacturing. This power supply shall have below certificates for ITE category:

1. UL
2. C-UL
3. TUV
4. CCC
5. CB
6. CISPR Class **A**
7. FCC Class **A**
8. RoHS (Full ROHS lead free 6/6)
9. BSMI

The power supply, when installed in the system, shall meet immunity requirements specified in EN55024.

Specific tests are to be EN61000-4-2, -3, -4, -5, -6, -8, and -11. The power supply must maintain normal performance within specified limits. Conformance must be designated with the European Union CE Marking. Specific immunity level requirements are left to customer requirements.

13. Environmental Requirements

13.1 Temperature

The power supply shall operate within all specified limits over T_{op} temperature range. All airflow shall pass through the power supply and not over the exterior surfaces of the power supply.

<i>Thermal Requirements</i>				
Item	Description	MIN	MAX	Units
T_{op}	Operating temperature range	0	45	Degree C
T_{non-op}	Non-operating temperature range	-40	70	Degree C

The power supply must meet UL enclosure requirements for temperature rise limits. All sides of the power supply, with exception to the air exhaust side, must be classified as “Handle, Knobs, grips, etc. held for short periods of time only.

13.2 Humidity:

Operating : 20% to 90% RH

Storage : 5% to 95% RH

13.3 Altitude:

Operating: to 10,000 feet (3,023 meters)

Non-operating: to 35,000 feet (10,580 meters)

13.4 Shock and Vibration

Mechanical Shock

The device will withstand the following imposed conditions without electrical or mechanical failure:

- Non-operating Square Wave Shock: 40G, Square wave at 200in/sec (508cm/sec); on all six sides
- Non-operating Half Sine Shock: Half Sine pulse for 70in/sec (178cm/sec) for 2ms; on all sides except top
- Operating Half Sine Shock: Half Sine pulse for 40in/sec (102cm/sec) for 2ms; on all sides except top

Vibration

- Operating: Sinusoidal vibration, 0.5G (0-peak) acceleration. 5-500Hz, sweep at 1/2 octave/min from low to high frequency, and then from high to low. Thirty minute dwell at all resonant points, where resonance is defined as those exciting frequencies at which the device under test experiences excursions two times larger than non-resonant excursions.
- Plane of vibration to be along three mutually perpendicular axis.
- Non-operating: Sinusoidal vibration, 1.0G (0-peak) acceleration. 5-500Hz, sweep at 1/2 octave/min from low to high frequency, and then from high to low. Thirty minute dwell at all resonant points, where resonance is defined as those exciting frequencies at which the device under test experiences excursions two times larger than non-resonant excursions.

Thermal Shock

Non-operating: -40 (+/-5) to +70 (+/-5) degrees Celsius, transition time not to exceed 5 minutes.

Duration of exposure to temperature extremes will be 20 minutes.

14. Serial number:

CPR-1621-1M21: P16211M21YWWRMSSSS

15. Mechanical Drawing

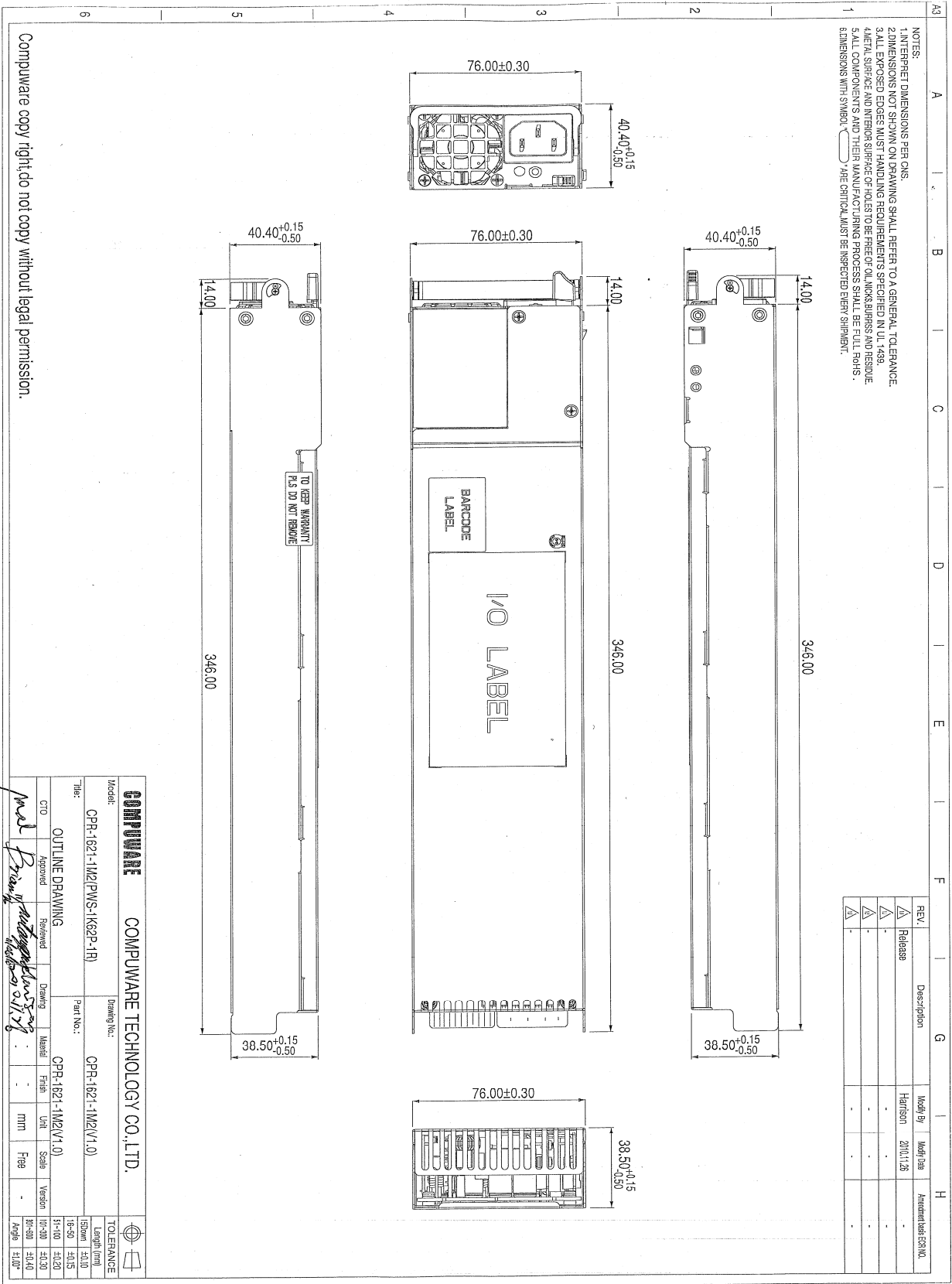

NOTES:
 1. INTERPRET DIMENSIONS PER CNS.
 2. DIMENSIONS NOT SHOWN ON DRAWING SHALL REFER TO A GENERAL TOLERANCE.
 3. ALL EXPOSED EDGES MUST HANDLE REQUIREMENTS SPECIFIED IN I.L. 149.
 4. ALL SURFACE AND INTERIOR SURFACE OF HOLES TO BE FREE OF OIL, MARKS, BIRRS, AND RESINIE.
 5. ALL COMPONENTS AND THEIR MANUFACTURING PROCESS SHALL BE FULLY R.O.H.S.
 6. DIMENSIONS WITH SYMBOL M ARE CRITICAL, MUST BE INSPECTED EVERY SHIPMENT.

REV.	Description	Modify By	Modify Date	Amendment Code
1	Release	Harrison	2010.11.28	-
2				
3				

COMPUWARE		COMPUWARE TECHNOLOGY CO., LTD.	
Model:	CPR-1621-1M2(PMS-K82P-1R)	Drawing No.:	CPR-1621-1M2(V1.0)
Title:	OUTLINE DRAWING	Part No.:	CPR-1621-1M2(V1.0)
CTO	Approved	Reviewed	Drawing
			Model
			Finish
			Unit
			Scale
			Version
			1:1
			1:2
			1:5
			1:10
			1:20
			1:50
			1:100
			1:200
			1:500
			1:1000
			1:2000
			1:5000
			1:10000
			1:20000
			1:50000
			1:100000
			1:200000
			1:500000
			1:1000000
			1:2000000
			1:5000000
			1:10000000
			1:20000000
			1:50000000
			1:100000000
			1:200000000
			1:500000000
			1:1000000000
			1:2000000000
			1:5000000000
			1:10000000000
			1:20000000000
			1:50000000000
			1:100000000000
			1:200000000000
			1:500000000000
			1:1000000000000
			1:2000000000000
			1:5000000000000
			1:10000000000000
			1:20000000000000
			1:50000000000000
			1:100000000000000
			1:200000000000000
			1:500000000000000
			1:1000000000000000
			1:2000000000000000
			1:5000000000000000
			1:10000000000000000
			1:20000000000000000
			1:50000000000000000
			1:100000000000000000
			1:200000000000000000
			1:500000000000000000
			1:1000000000000000000
			1:2000000000000000000
			1:5000000000000000000
			1:10000000000000000000
			1:20000000000000000000
			1:50000000000000000000
			1:100000000000000000000
			1:200000000000000000000
			1:500000000000000000000
			1:1000000000000000000000
			1:2000000000000000000000
			1:5000000000000000000000
			1:10000000000000000000000
			1:20000000000000000000000
			1:50000000000000000000000
			1:100000000000000000000000
			1:200000000000000000000000
			1:500000000000000000000000
			1:1000000000000000000000000
			1:2000000000000000000000000
			1:5000000000000000000000000
			1:10000000000000000000000000
			1:20000000000000000000000000
			1:50000000000000000000000000
			1:100000000000000000000000000
			1:200000000000000000000000000
			1:500000000000000000000000000
			1:1000000000000000000000000000
			1:2000000000000000000000000000
			1:5000000000000000000000000000
			1:10000000000000000000000000000
			1:20000000000000000000000000000
			1:50000000000000000000000000000
			1:100000000000000000000000000000
			1:200000000000000000000000000000
			1:500000000000000000000000000000
			1:1000000000000000000000000000000
			1:2000000000000000000000000000000
			1:5000000000000000000000000000000
			1:10000000000000000000000000000000
			1:20000000000000000000000000000000
			1:50000000000000000000000000000000
			1:100000000000000000000000000000000
			1:200000000000000000000000000000000
			1:500000000000000000000000000000000
			1:1000000000000000000000000000000000
			1:2000000000000000000000000000000000
			1:5000000000000000000000000000000000
			1:10000000000000000000000000000000000
			1:20000000000000000000000000000000000
			1:50000000000000000000000000000000000
			1:100000000000000000000000000000000000
			1:200000000000000000000000000000000000
			1:500000000000000000000000000000000000
			1:1000000000000000000000000000000000000
			1:2000000000000000000000000000000000000
			1:5000000000000000000000000000000000000
			1:10000000000000000000000000000000000000
			1:20000000000000000000000000000000000000
			1:50000000000000000000000000000000000000
			1:100000000000000000000000000000000000000
			1:200000000000000000000000000000000000000
			1:500000000000000000000000000000000000000
			1:1000000000000000000000000000000000000000
			1:2000000000000000000000000000000000000000
			1:5000000000000000000000000000000000000000
			1:100
			1:200
			1:500
			1:1000
			1:2000
			1:5000
			1:100
			1:200
			1:500
			1:1000
			1:2000
			1:5000
			1:100
			1:200
			1:500
			1:1000
			1:2000
			1:5000
			1:100
			1:200
			1:500
			1:1000
			1:2000
			1:5000
			1:100
			1:200
			1:500
			1:1000
			1:2000
			1:5000
			1:100
			1:200
			1:500
			1:1000
			1:2000
			1:5000
			1:100
			1:200
			1:500
			1:1000
			1:2000
			1:5000
			1:100
			1:200
			1:500
			1:1000
			1:2000
			1:5000
			1:100
			1:200
			1:500
			1:1000
			1:2000
			1:5000
			1:100
			1:200
			1:500
			1:1000
			1:2000
			1:5000
			1:100
			1:200
			1:500
			1:1000
			1:200000